

# Overview of Design for Manufacturing and Assembly (DFMA)

By David K. Porter, P.E.  
Crystal Engineering Corp

# My Background

- Director of Engineering, Crystal Engineering Corp
- Cal Poly, ME Grad, 1985
- Industries worked:
  - Instrumentation
    - Director/Crystal Engr Corp
  - Telecom Test and Measurement
    - Director/Newport Corp
  - Heavy Duty Automotive
    - Director/ECCO
  - Medical
    - Director/Orbis International

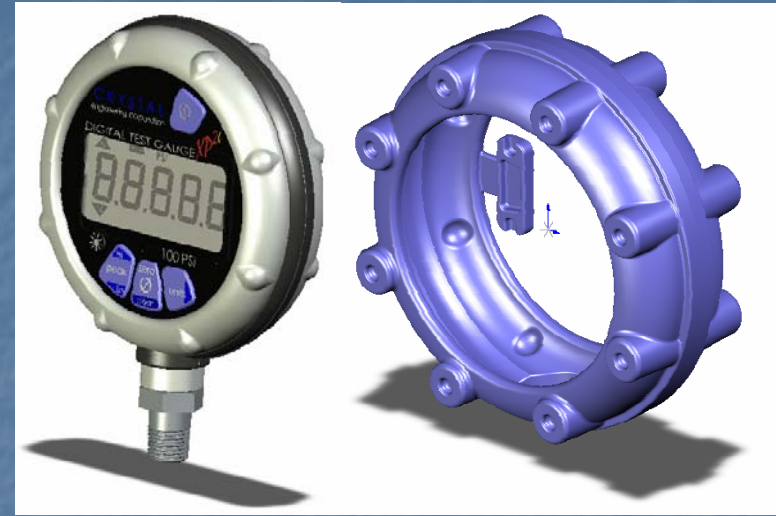

Our Competition

# DFMA

- Overview of Today's Discussion:
  - Definition of DFMA
  - Examples
  - Design Guidelines
  - How will this help me in the future?
    - Employers look for students with advanced design skills such as knowledge of DFMA and World Class Manufacturing

# DFMA

- What is DFMA?
- Def'n: Design for Manual Assembly and/or Design for Manufacture and Assembly
- Why is this important to engineers and why are they the last to learn of it's benefits?
  - Why show me this now?
  - Why is this discipline the last to be adopted in design engineering

# DFMA

## ■ Example 1:

Looks OK,  
right?

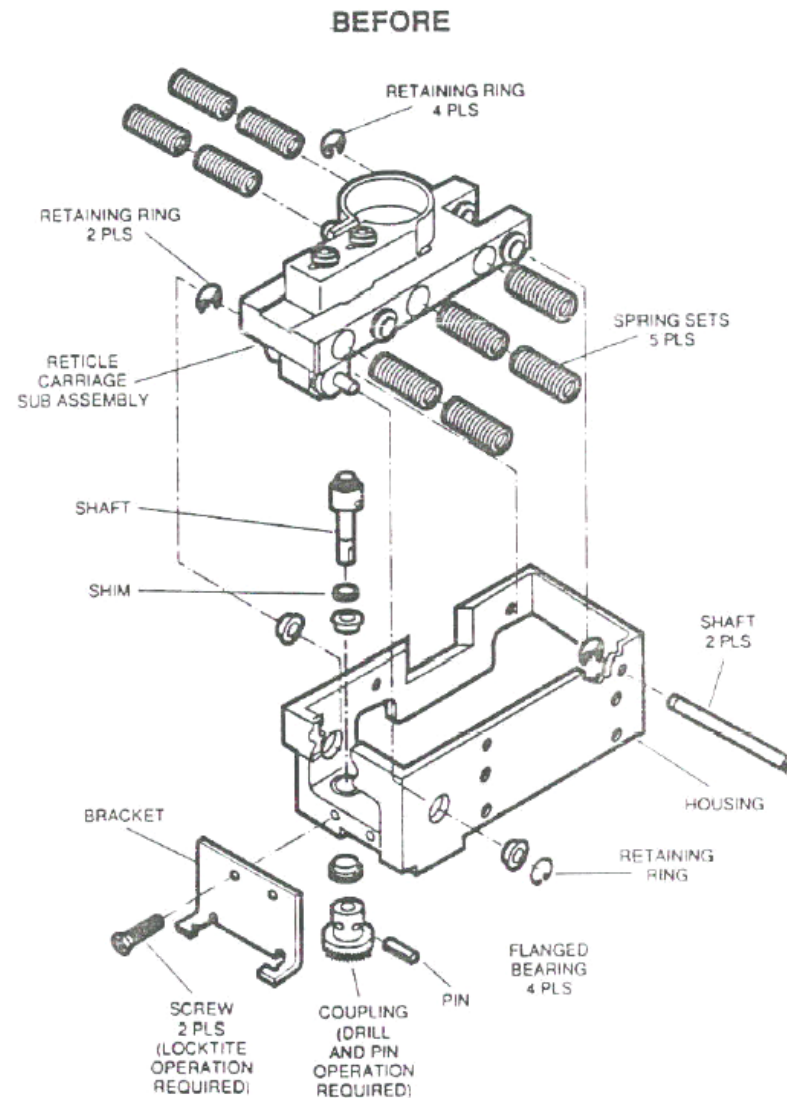

Figure 1.11 Reticle assembly—original design. (Courtesy Texas Instruments, Inc.)

# DFMA

## ■ Example 1:

After DFMA

What a  
difference!

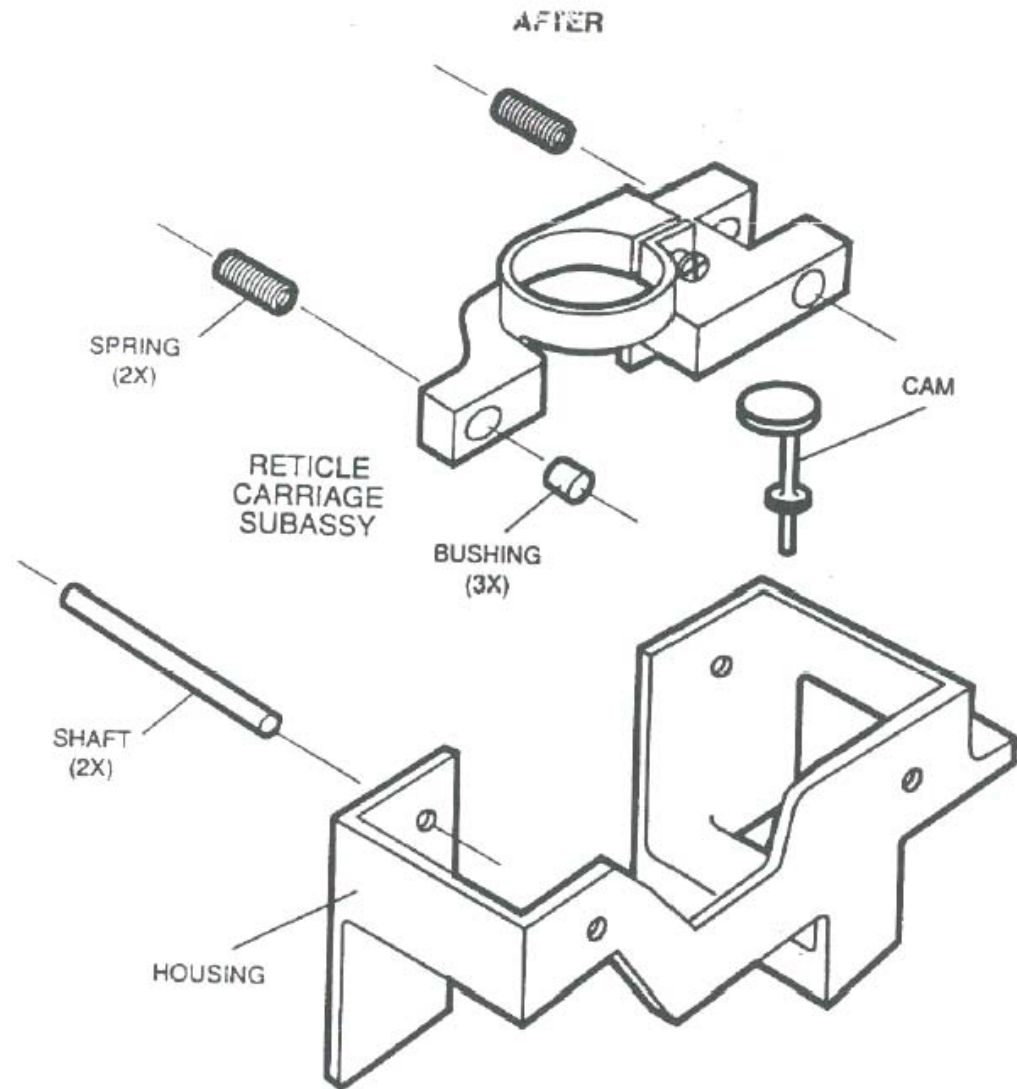

**Figure 1.12** Reticle assembly—new design. (Courtesy Texas Instruments, Inc.)

# DFMA

- The IMPACT of DFMA on Example 1:
  - Less parts to design, document, revise
  - Less Bill of Material (BOM) cost, parts to receive, inspect, store, handle
  - Less labor and energy to build product
  - Gets into the customer's hands faster
  - Less complexity
  - Simpler assembly instructions
  - Higher quality
  - Higher profit margin
  - More competitive in the marketplace

# DFMA

## ■ Advantages

- Quantitative method to assess design
- Communication tool with other engineering disciplines and other departments (Sales, etc.)
- Greater role for other groups while still in the “engineering” phase such as Manufacturing
- Since almost 75% of the product cost is determined in the “engineering” phase, it gives a tool to attack those hidden waste areas before committing to a design
- *Fact: Fasteners typically account for 5% of BOM cost, yet contribute to 70% of the labor cost!*

# DFMA

## ■ Example 2

### Motor Drive

### Proposed Design

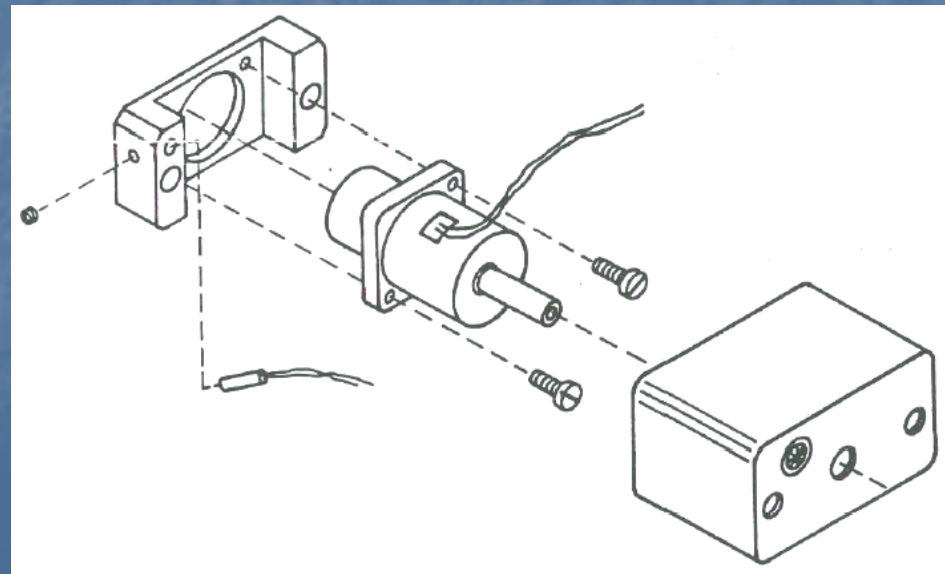
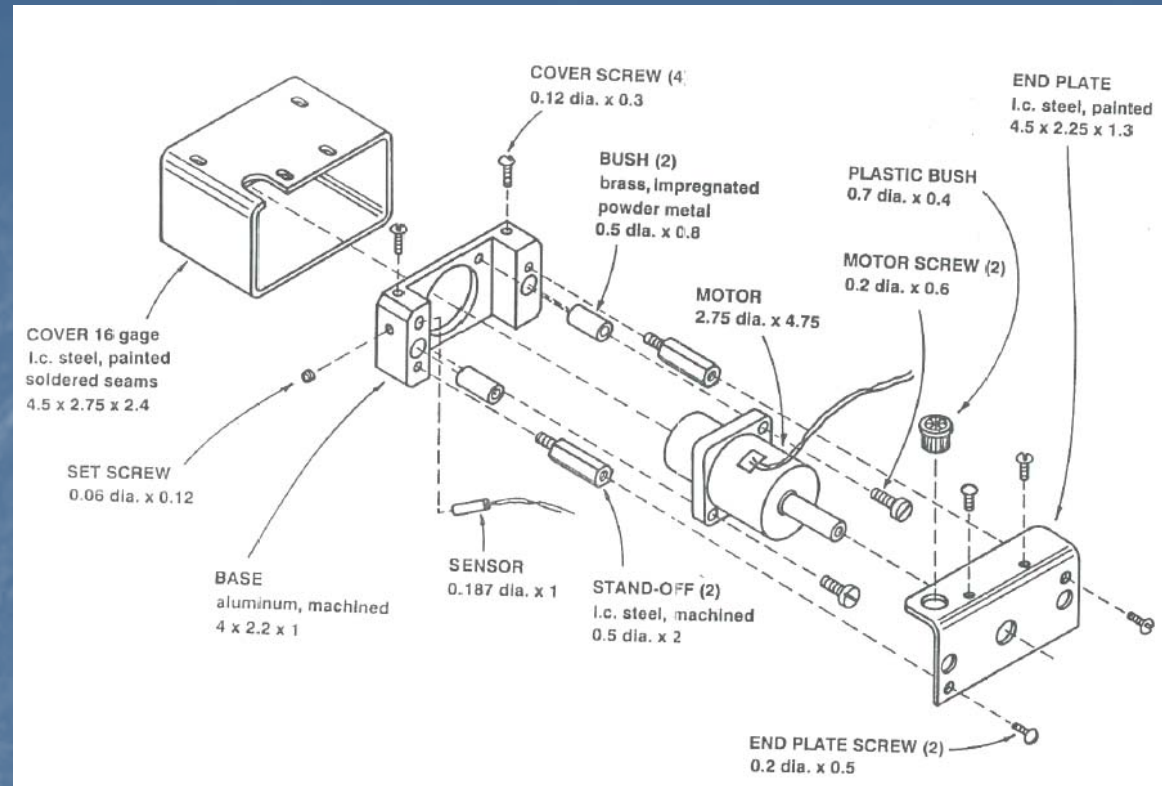

### Final Design

# DFMA

## ■ Example 3

### Power Saw

### Project

### (Original Test Case)

### Facts:

41 vs. 29 Parts

6.37 vs. 2.58 min

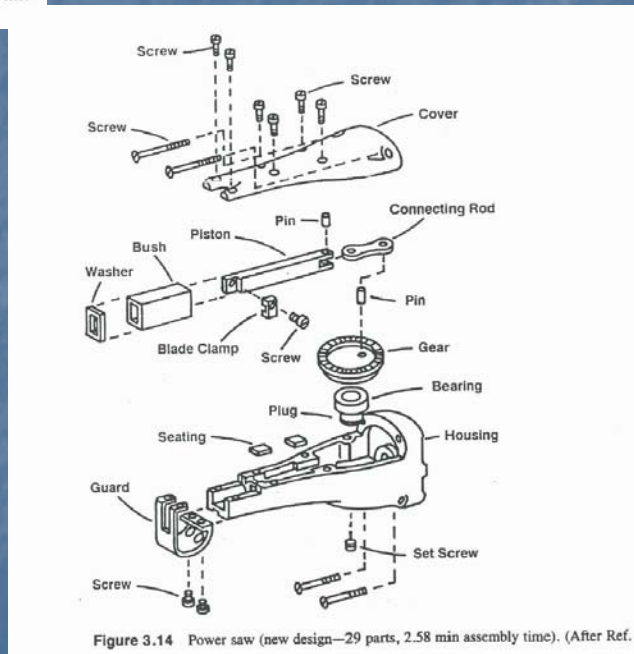
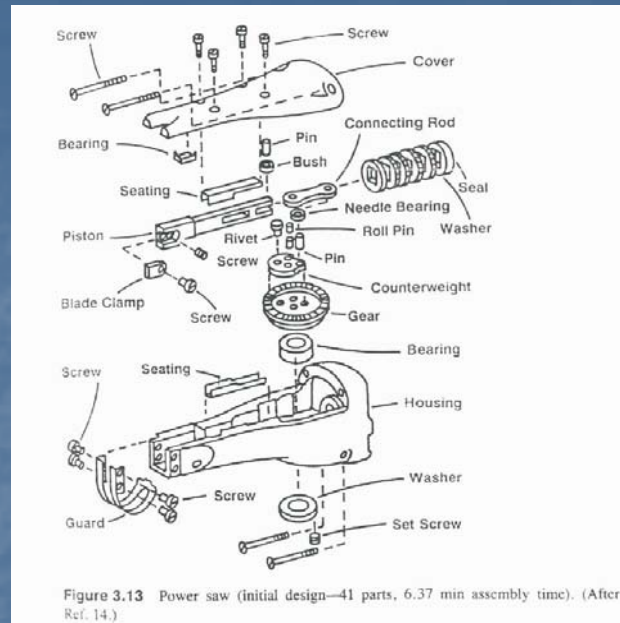

# DFMA

## ■ History:

- Formal methods began in late 70's
- Empirical studies followed for handling parts
- System for estimating assembly times followed in early 80's
- Geoffrey Boothroyd pioneered system while at U of Mass on Power Saw project (just shown)

# DFMA

- Each part has a handling and insertion time penalty
  - The more complex the part the larger the time penalty
  - The more precise the alignment the heavier the penalty

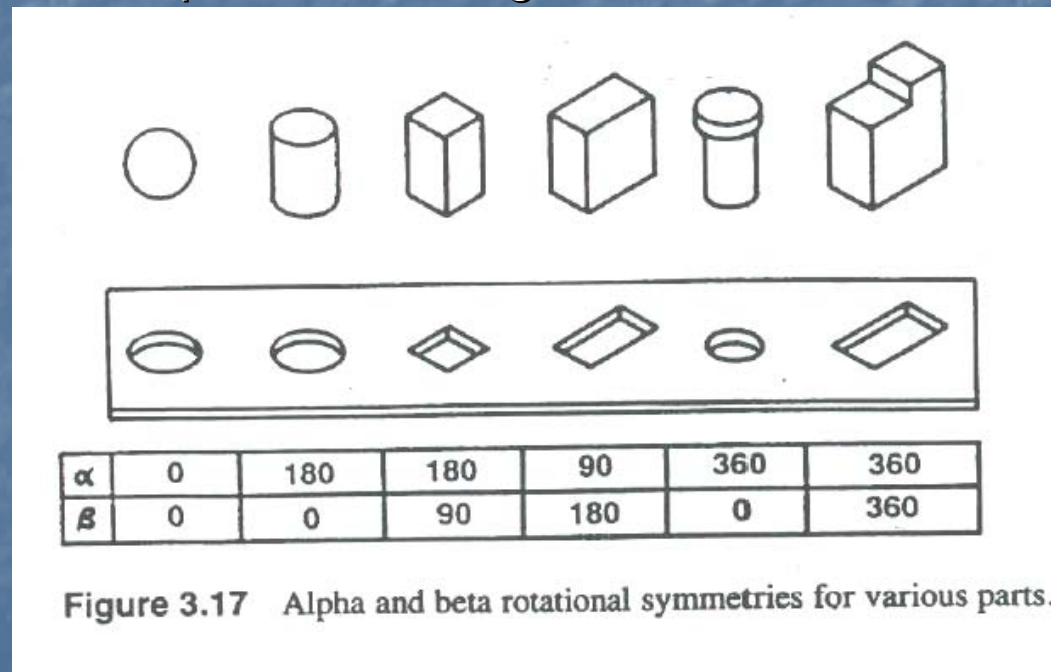

- Data compiled by time studies of such manufacturers as Motorola

# DFMA

- Chart established for Handling

**MANUAL HANDLING — ESTIMATED TIMES (seconds)**

**Key:**  
 ONE HAND

	parts are easy to grasp and manipulate					parts present handling difficulties (1)						
	thickness > 2 mm		thickness ≤ 2 mm			thickness > 2 mm		thickness ≤ 2 mm				
	size > 15 mm	6 mm ≤ size ≤ 15 mm	size < 6 mm	size > 6 mm	size ≤ 6 mm	size > 15 mm	6 mm ≤ size ≤ 15 mm	size < 6 mm	size > 6 mm	size ≤ 6 mm		
	0	1	2	3	4	5	6	7	8	9		
parts can be grasped and manipulated by one hand without the aid of grasping tools	$(\alpha + \beta) < 360^\circ$	0	1.13	1.43	1.88	1.69	2.18	1.84	2.17	2.65	2.45	2.98
	$360^\circ \leq (\alpha + \beta) < 540^\circ$	1	1.5	1.8	2.25	2.06	2.55	2.25	2.57	3.06	3	3.38
	$540^\circ \leq (\alpha + \beta) < 720^\circ$	2	1.8	2.1	2.55	2.36	2.85	2.57	2.9	3.38	3.18	3.7
	$(\alpha + \beta) = 720^\circ$	3	1.95	2.25	2.7	2.51	3	2.73	3.06	3.55	3.34	4

**ONE HAND with GRASPING AIDS**

	parts need tweezers for grasping and manipulation											
	parts can be manipulated without optical magnification					parts require optical magnification for manipulation						
	parts are easy to grasp and manipulate		parts present handling difficulties (1)			parts are easy to grasp and manipulate		parts present handling difficulties (1)			parts need standard tools other than tweezers	parts need special tools for grasping and manipulation
	thickness > 0.25 mm	thickness ≤ 0.25 mm	thickness > 0.25 mm	thickness ≤ 0.25 mm	thickness > 0.25 mm	thickness ≤ 0.25 mm	thickness > 0.25 mm	thickness ≤ 0.25 mm	thickness > 0.25 mm	thickness ≤ 0.25 mm	8	9
parts can be grasped and manipulated by one hand but only with the use of grasping tools	$0 \leq \beta \leq 180^\circ$	4	3.6	6.85	4.35	7.6	5.6	8.35	6.35	8.6	7	7
	$\beta = 360^\circ$	5	4	7.25	4.75	8	6	8.75	6.75	9	8	8
	$0 \leq \beta \leq 180^\circ$	6	4.8	8.05	5.55	8.8	6.8	9.55	7.55	9.8	8	9
	$\beta = 360^\circ$	7	5.1	8.35	5.85	9.1	7.1	9.55	7.85	10.1	9	10

**TWO HANDS for MANIPULATION**

	parts present no additional handling difficulties					parts present additional handling difficulties (e.g. sticky, delicate, slippery, etc.) (1)					
	$\alpha \leq 180^\circ$		$\alpha = 360^\circ$			$\alpha \leq 180^\circ$		$\alpha = 360^\circ$			
	size > 15 mm	6 mm ≤ size ≤ 15 mm	size < 6 mm	size > 6 mm	size ≤ 6 mm	size > 15 mm	6 mm ≤ size ≤ 15 mm	size < 6 mm	size > 6 mm	size ≤ 6 mm	
	0	1	2	3	4	5	6	7	8	9	
parts severely nest or tangle or are flexible but can be grasped and lifted by one hand (with the use of grasping tools if necessary) (2)	8	4.1	4.5	5.1	5.6	6.75	5	5.25	5.85	6.35	7

**TWO HANDS required for LARGE SIZE**

	parts can be handled by one person without mechanical assistance								parts severely nest or tangle or are flexible (2)	two persons or mechanical assistance required for parts manipulation	
	parts do not severely nest or tangle and are not flexible				parts are heavy (> 10 lb)						
	part weight < 10 lb		parts are heavy (> 10 lb)		parts are easy to grasp and manipulate		parts present other handling difficulties (1)				
	parts are easy to grasp and manipulate	parts present other handling difficulties (1)	parts are easy to grasp and manipulate	parts present other handling difficulties (1)	$\alpha \leq 180^\circ$	$\alpha = 360^\circ$	$\alpha \leq 180^\circ$	$\alpha = 360^\circ$	8	9	
two hands, two persons or mechanical assistance required for grasping and transporting parts	9	2	3	2	3	3	4	4	5	7	9

# DFMA

## ...and Insertion

MANUAL INSERTION – ESTIMATED TIMES (seconds)

		after assembly no holding down required to maintain orientation and location (3)				holding down required during subsequent processes to maintain orientation or location (3)			
		easy to align and position during assembly (4)		not easy to align or position during assembly		easy to align and position during assembly (4)		not easy to align or position during assembly	
		no resistance to insertion	resistance to insertion (5)	no resistance to insertion	resistance to insertion (5)	no resistance to insertion	resistance to insertion (5)	no resistance to insertion	resistance to insertion (5)
		0	1	2	3	6	7	8	9
addition of any part (1) where neither the part itself nor any other part is finally secured immediately part and associated tool (including hands) can easily reach the desired location	0	1.5	2.5	2.5	3.5	5.5	6.5	6.5	7.5
	1	4	5	5	6	8	9	9	10
	2	5.5	6.5	6.5	7.5	9.5	10.5	10.5	11.5
addition of any part (1) where the part itself and/or other parts are being finally secured immediately part and associated tool (including hands) cannot easily reach desired location or tool cannot be operated easily	3	2	5	4	5	6	7	8	8
	4	4.5	7.5	6.5	7.5	8.5	9.5	10.5	10.5
	5	6	9	8	9	10	11	12	12
assembly processes where all solid parts are in place	9	4	7	5	3.5	7	8	12	12

		no screwing operation or plastic deformation immediately after insertion (snap/press fits, circlips, spire nuts, etc.)				plastic deformation immediately after insertion				screw tightening immediately after insertion (6)			
		easy to align and position during assembly (4)		not easy to align or position during assembly		plastic bending		rivetting or similar operation					
		easy to align and position with no resistance to insertion (4)	not easy to align or position during assembly and/or friction (5)	easy to align and position during assembly (4)	not easy to align or position during assembly	no resistance to insertion	resistance to insertion (5)	easy to align and position during assembly (4)	not easy to align or position during assembly	no resistance to insertion	resistance to insertion (5)	easy to align and position with no torsional resistance (4)	not easy to align or position and/or torsional resistance (5)
		0	1	2	3	4	5	6	7	8	9	8	9
addition of any part (1) where the part itself and/or other parts are being finally secured immediately part and associated tool (including hands) cannot easily reach desired location or tool cannot be operated easily	3	2	5	4	5	6	7	8	9	6	8	8	8
	4	4.5	7.5	6.5	7.5	8.5	9.5	10.5	11.5	8.5	10.5	8.5	10.5
	5	6	9	8	9	10	11	12	13	10	12	10	12

		mechanical fastening processes (part(s) already in place but not secured immediately after insertion)				non-mechanical fastening processes (part(s) already in place but not secured immediately after insertion)				non-fastening processes		
		none or localized plastic deformation		metallurgical processes		chemical processes (e.g. adhesive bonding, etc.)		manipulation of parts or sub-assembly (e.g. orienting, fitting or adjustment of parts), etc.)		other processes (e.g. liquid insertion, etc.)		
		bending or similar processes	rivetting or similar processes	screw tightening (8) or other processes	bulk plastic deformation (large proportion of part is plastically deformed during fastening)	no additional material required (e.g. resistance, friction welding, etc.)	additional material required	soldering processes	weld/brazing processes	chemical processes (e.g. adhesive bonding, etc.)	manipulation of parts or sub-assembly (e.g. orienting, fitting or adjustment of parts), etc.)	other processes (e.g. liquid insertion, etc.)
		0	1	2	3	4	5	6	7	8	9	
SEPARATE OPERATION	9	4	7	5	3.5	7	8	12	12	9	12	

Key:  
 PART ADDED but NOT SECURED

PART SECURED IMMEDIATELY

SEPARATE OPERATION

# DFMA – Quick Analysis

<b>Example A</b>											
<u>Assembly Name:</u>		<u>Date:</u>		Select Cell then Press MHCalc button		Select Cell then Press MHCalc button		Operator Rate=			
								Factor =			
Item Name: Part Sub or PCB Assembly or Operation	Quantity	Handling Code	MH CALC	Insertion Code	MI CALC	Unit Operation Time (sec)	Unit Operation Cost (\$)	Unit Material Cost (\$)	Unit Part Cost (\$)	Extended Part Cost (\$)	Extended Operation Time (min)
			Time per Item (sec)		Time per Item (sec)						
Box on Worksurface	1	02	1.8	60	5.5	7.3	0.0304		0.0304	0.03	0.12
Place assy	1	02	1.8	00	1.5	3.3	0.0138		0.0138	0.01	0.06
Screw down Assy	4	01	1.5	85	10.0	11.5	0.0479		0.0479	0.19	0.77
Cover	1	00	1.1	00	1.5	2.6	0.0110		0.0110	0.01	0.04
									<b>Total</b>	<b>\$0.25</b>	<b>\$0.99</b>
<b>Example B</b>											
<u>Assembly Name:</u>		<u>Date:</u>		Select Cell then Press MHCalc		Select Cell then Press MHCalc		Operator Rate=			
								Factor =			
Item Name: Part Sub or PCB Assembly or Operation	Quantity	Handling Code	MH CALC	Insertion Code	MI CALC	Unit Operation Time (sec)	Unit Operation Cost (\$)	Unit Material Cost (\$)	Unit Part Cost (\$)	Extended Part Cost (\$)	Extended Operation Time (min)
			Time per Item (sec)		Time per Item (sec)						
Plate on Worksurface	1	01	1.5	60	5.5	7.0	0.0292		0.0292	0.03	0.13
Place assy	1	02	1.8	60	5.5	7.3	0.0304		0.0304	0.03	0.12
Screw down Assy	4	01	1.5	83	6.0	7.5	0.0313		0.0313	0.13	0.50
Cover	1	02	1.8	00	1.5	3.3	0.0138		0.0138	0.01	0.06
									<b>Total</b>	<b>\$0.20</b>	<b>\$0.81</b>

Restricted access for assembly of screws

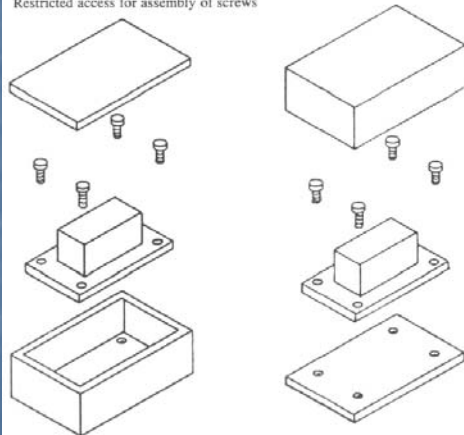

Figure 3.40 Design concept to provide easier access during assembly.

# DFMA

- DFMA.com Software

The screenshot displays the Design For Assembly 9.1 software interface. The main window shows a 3D exploded view of a motor assembly. A tree view on the left lists the components: motor base, bushing, motor, motor screw, stand-off, sensor, and set screw. The central panel provides detailed information for the selected 'motor base' part, including its name, part number (5678), and repeat count (1). It also lists various securing methods (e.g., secured later, thread, snap) and handling difficulties (e.g., nest tangle, severe tangle, flexible). A 'Graph' window in the bottom right corner shows a bar chart of 'Total cost per product, \$' for different categories: Labor, Tool or fixture, Tooling, Piece part, and Other operation. The 'Piece part' category has the highest cost, exceeding 45.00.

Category	Total cost per product, \$
Labor	~3.00
Tool or fixture	~1.00
Tooling	~6.00
Piece part	~48.00
Other operation	~27.00

# DFMA

## ■ Example 4

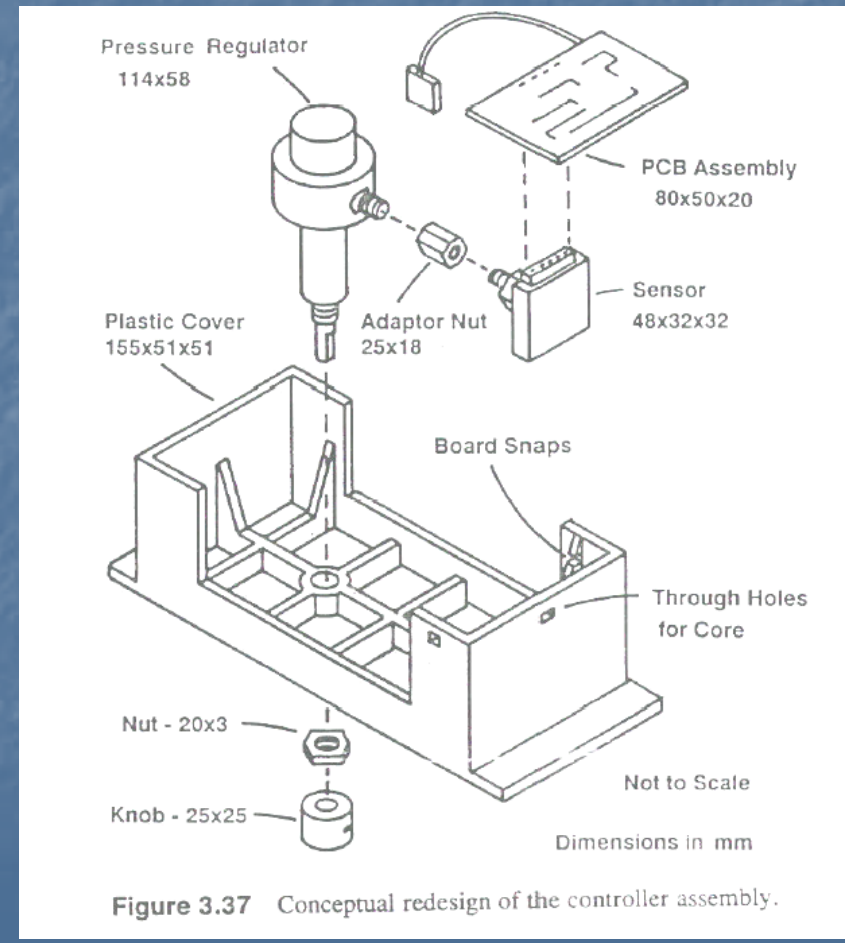
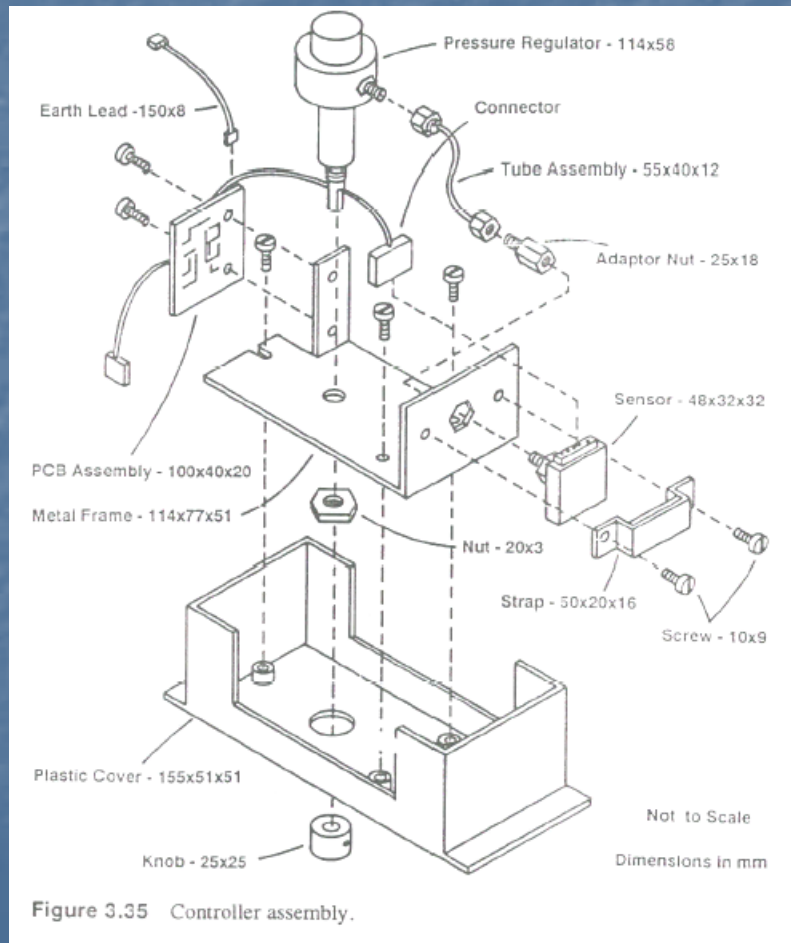

# DFMA

## The Waste of Complexity:

- The goal is to achieve simple solutions in place of complex ones
- Complex solutions tend to produce more waste and are harder for people to manage
- Waste can take the form of time, energy, labor, defective production, etc.
  - In our case, replace “solution” with “design”

# DFMA

- Who is using it?....the same people who first adopted Solid Modeling.....
  - Boeing / Lockheed Martin / Northrop Grumman / McDonnell Douglas
  - Hewlett-Packard
  - Ford / GM / Chrysler
  - Texas Instruments
  - Toy manufacturers
  - Your future employer.....
  - The list goes on and on.....

# DFMA

## ■ Examples.....

### ■ Longbow Apache Helicopter

#### ■ Pilot Instrument Panel:

Fabrication/Assembly/Installation time reduced from 697 hours to 181!

#### ■ Co-Pilot Instrument Panel:

■ Part count 12, down from 87

### ■ C-17:

■ 9 million components, 1 million man hrs to build

■ DFMA on landing gear bulk head went from 72 detail parts and 1,720 fasteners to 2 parts and 35 fasteners! (McDonnell Douglas)

(Examples from DFMA.com)

# DFMA – Design Guidelines

- Design for top down assembly
- Make parts self locating
- Try to design parts with symmetry
- If symmetry is not possible then make it obvious that the part needs a specific orientation

# DFMA – Design Guidelines

- Prevent stacked parts from getting stuck together or tangled using features
- Avoid parts that are difficult to handle, i.e. too small, sharp, fragile, etc.
- Avoid parts that only connect. Try and bring the other parts together to eliminate the connection
- Avoid adjustments. In general, adjustments compensate for poor design

# DFMA - Guidelines

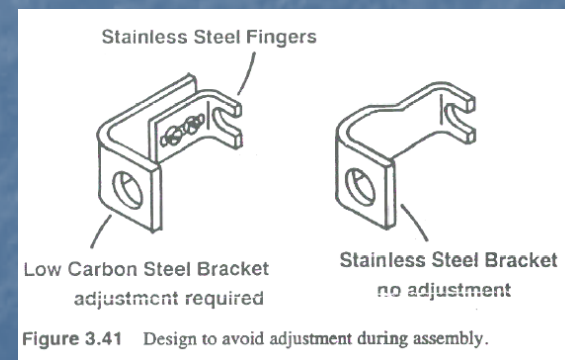
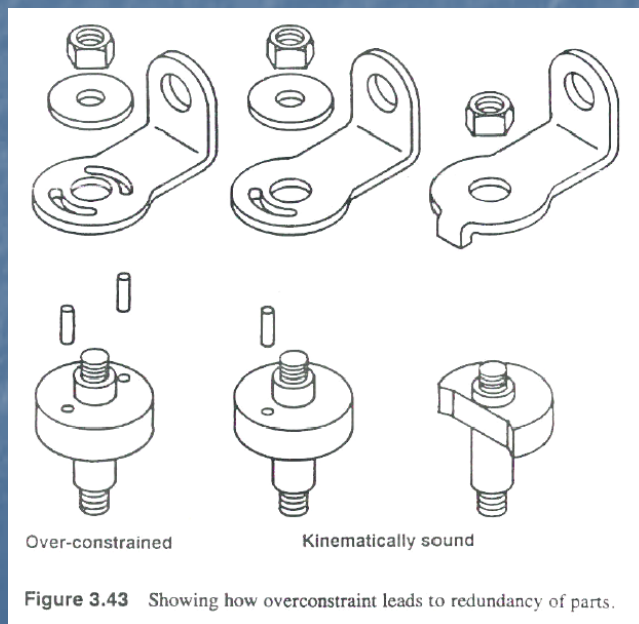
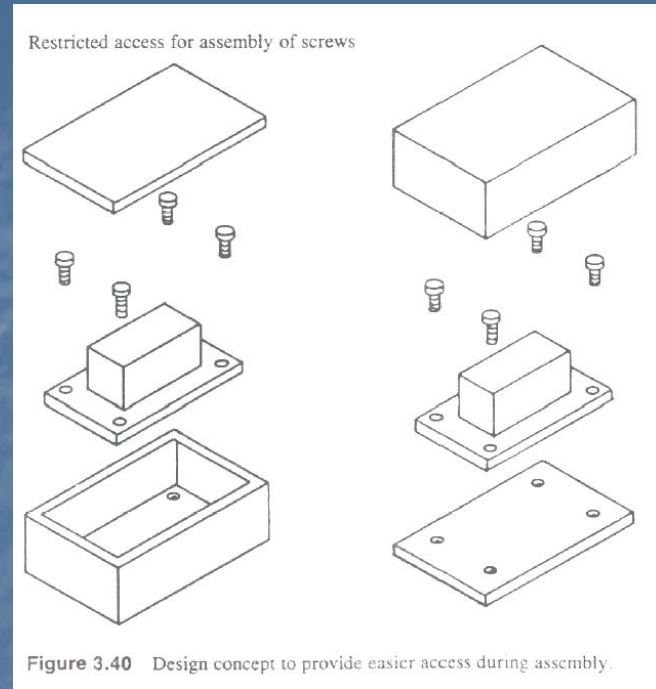
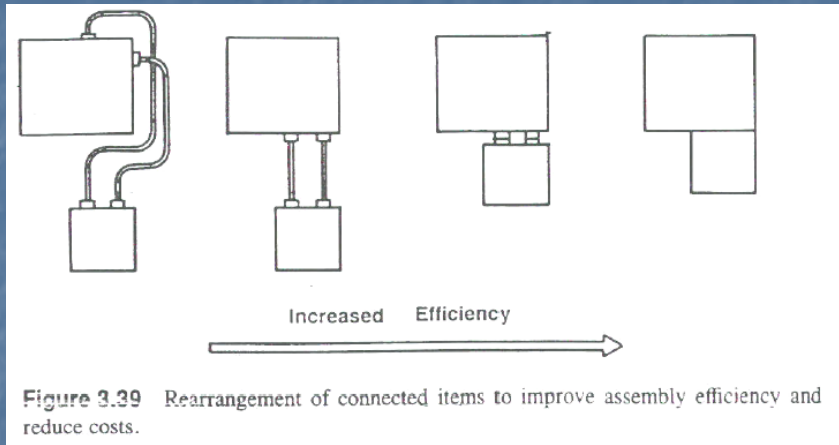

# DFMA - Guidelines

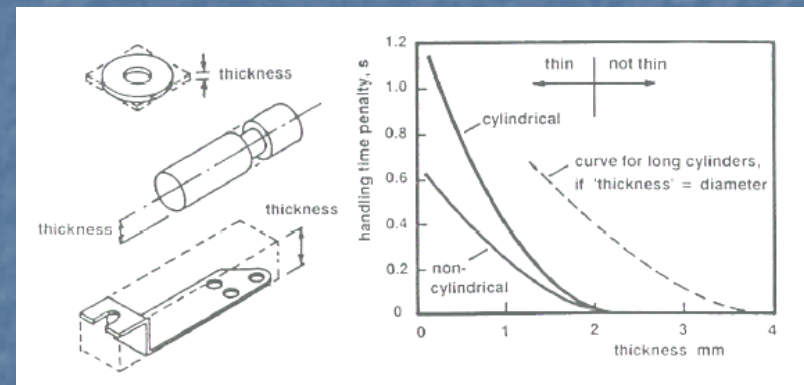
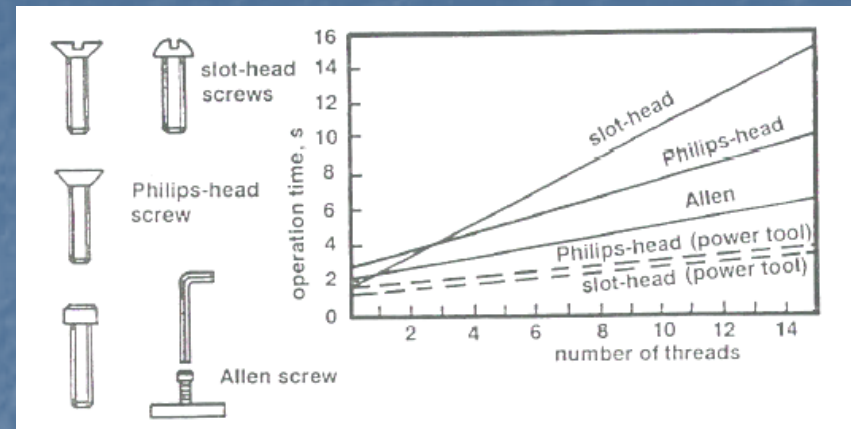
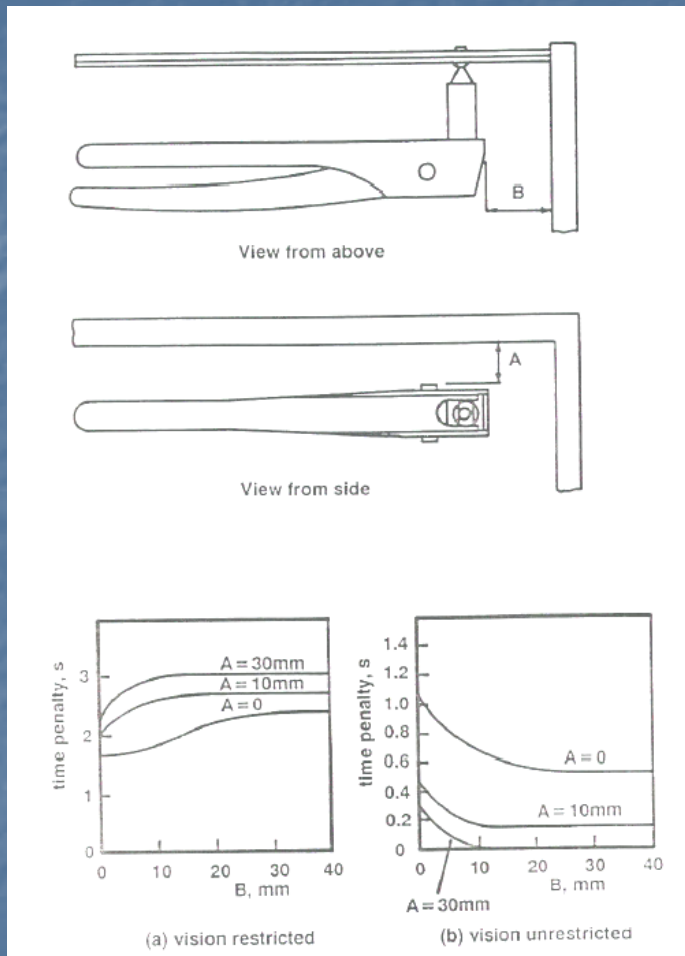

# DFMA

Your Cal Poly Education will:

- Teach you to use powerful tools such as SolidWorks
  - This tool will allow you to design using the DFMA philosophy.....parts reduction
  - Make sure you use the tool to the fullest!
- *Remember...it is very difficult to make things simple.....*

# DFMA

- Good websites for further info on DFMA and World Class Manufacturing:
  - npd-solutions.com (best website by far!)
  - DFMA.com (Boothroyd and Dewhurst products)
  - Superfactory.com
- Sources of information used:
  - Larry Stauffer, Ph.D, P.E., University of Idaho – TechHelp
  - David E. Lee and Thomas H. Hahn, A Coordinated Product and Process Development Environment for Design for Assembly, 1996