CHAPTER 27

FITS AND TOLERANCES

Joseph E. Shigley
Professor Emeritus
The University of Michigan
Ann Arbor, Michigan

Charles R. Mischke, Ph.D., P.E.
Professor Emeritus of Mechanical Engineering
Iowa State University
Ames, Iowa

27.1 INTRODUCTION / 27.2
27.2 METRIC STANDARDS / 27.2
27.3 U.S. STANDARD—INCH UNITS / 27.9
27.4 INTERFERENCE-FIT STRESSES / 27.9
27.5 ABSOLUTE TOLERANCES / 27.13
REFERENCES / 27.16

NOMENCLATURE

a	Radius
B	Smallest bore diameter
b	Radius
c	Radius radial clearance
D	Diameter, mean of size range, largest journal diameter
E	Young's modulus
e	Bilateral tolerance expressing error
L	Upper or lower limit
p	Probability
p_f	Probability of failure
t	Bilateral tolerance of dimension
w	Left-tending vector representing gap
x	Right-tending dimensional vector magnitude
y	Left-tending dimensional vector magnitude
δ	Radial interference
ν	Poisson's ratio
σ	Normal stress
σ	Standard deviation

27.1 INTRODUCTION

Standards of limits and fits for mating parts have been approved for general use in the United States for use with U.S. customary units [27.1] and for use with SI units [27.2]. The tables included in these standards are so lengthy that formulas are presented here instead of the tables to save space. As a result of rounding and other variations, the formulas are only close approximations. The nomenclature and symbols used in the two standards differ from each other, and so it is necessary to present the details of each standard separately.

27.2 METRIC STANDARDS

27.2.1 Definitions

Terms used are illustrated in Fig. 27.1 and are defined as follows:

1. *Basic size* is the size to which limits or deviations are assigned and is the same for both members of a fit. It is measured in millimeters.
2. *Deviation* is the algebraic difference between a size and the corresponding basic size.
3. *Upper deviation* is the algebraic difference between the maximum limit and the corresponding basic size.
4. *Lower deviation* is the algebraic difference between the minimum limit and the corresponding basic size.
5. *Fundamental deviation* is either the upper or the lower deviation, depending on which is closest to the basic size.
6. *Tolerance* is the difference between the maximum and minimum size limits of a part.
7. *International tolerance grade (IT)* is a group of tolerances which have the same relative level of accuracy but which vary depending on the basic size.
8. *Hole basis* represents a system of fits corresponding to a basic hole size.
9. *Shaft basis* represents a system of fits corresponding to a basic shaft size.

27.2.2 International Tolerance Grades

The *variation in part size*, also called the *magnitude of the tolerance zone*, is expressed in grade or IT numbers. Seven grade numbers are used for high-precision parts; these are

IT01, IT0, IT1, IT2, IT3, IT4, IT5

The most commonly used grade numbers are IT6 through IT16, and these are based on the Renard R5 geometric series of numbers. For these, the basic equation is

$$i = \frac{1}{1000} (0.45D^{1/3} + 0.001D) \quad (27.1)$$

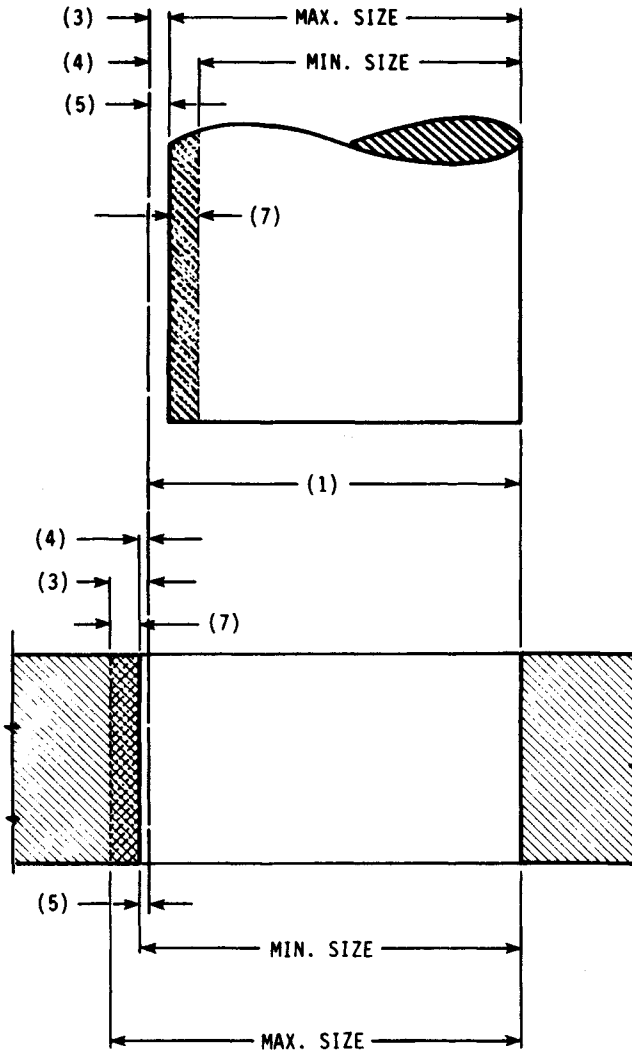

FIGURE 27.1 Definitions applied to a cylindrical fit. The numbers in parentheses are the definitions in Sec. 27.2.1.

where D is the geometric mean of the size range under consideration and is obtained from the formula

$$D = \sqrt{D_{\max}D_{\min}} \tag{27.2}$$

The ranges of basic sizes up to 1000 mm for use in this equation are shown in Table 27.1. For the first range, use $D_{\min} = 1$ mm in Eq. (27.2).

With D determined, tolerance grades IT5 through IT16 are found using Eq. (27.1) and Table 27.2. The grades IT01 to IT4 are computed using Table 27.3.

TABLE 27.1 Basic Size Ranges[†]

0-3	18-30	120-180	400-500
3-6	30-50	180-250	500-630
6-10	50-80	250-315	630-800
10-18	80-120	315-400	800-1000

[†]Sizes are for *over* the lower limit and *including* the upper limit (in millimeters).

TABLE 27.2 Formulas for Finding Tolerance Grades

Grade	Formula	Grade	Formula
IT5	$7i$	IT11	$100i$
IT6	$10i$	IT12	$160i$
IT7	$16i$	IT13	$250i$
IT8	$25i$	IT14	$400i$
IT9	$40i$	IT15	$640i$
IT10	$64i$	IT16	$1000i$

TABLE 27.3 Formulas for Higher-Precision Tolerance Grades

Grade	Formula
IT01	$(0.008D + 0.3)/1000$
IT0	$(0.012D + 0.5)/1000$
IT1	$(0.02D + 0.8)/1000$
IT2	$(IT1)[7i/(IT1)]^{1/4}$
IT3	$(IT2)^2$
IT4	$(IT2)^3$

27.2.3 Deviations

Fundamental deviations are expressed by *tolerance position letters* using capital letters for internal dimensions (holes) and lowercase letters for external dimensions (shafts). As shown by item 5 in Fig. 27.1, the fundamental deviation is used to position the tolerance zone relative to the basic size (item 1).

Figure 27.2 shows how the letters are combined with the tolerance grades to establish a fit. If the basic size for Fig. 27.2 is 25 mm, then the hole dimensions are defined by the ISO symbol

$$25D9$$

where the letter D establishes the fundamental deviation for the holes, and the number 9 defines the tolerance grade for the hole.

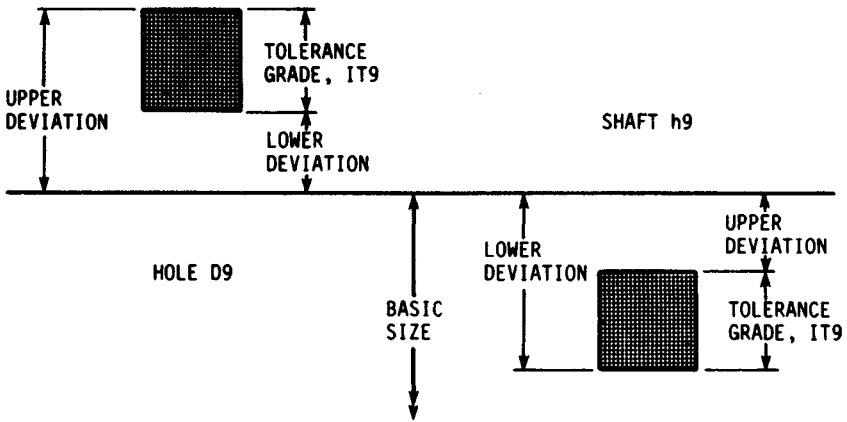

FIGURE 27.2 Illustration of a shaft-basis free-running fit. In this example the upper deviation for the shaft is actually zero, but it is shown as nonzero for illustrative purposes.

Similarly, the shaft dimensions are defined by the symbol

$$25h9$$

The formula for the fundamental deviation for shafts is

$$\text{Fundamental deviation} = \alpha + \frac{\beta D^\gamma}{1000} \tag{27.3}$$

where D is defined by Eq. (27.2), and the three coefficients are obtained from Table 27.4.

Shaft Deviations. For shafts designated a through h, the upper deviation is equal to the fundamental deviation. Subtract the IT grade from the fundamental deviation to get the lower deviation. Remember, the deviations are defined as algebraic, so be careful with signs.

Shafts designated j through zc have the lower deviation equal to the fundamental deviation. For these, the upper deviation is the sum of the IT grade and the fundamental deviation.

Hole Deviations. Holes designated A through H have a lower deviation equal to the negative of the upper deviation for shafts. Holes designated as J through ZC have an upper deviation equal to the negative of the lower deviation for shafts.

An exception to the rule occurs for a hole designated as N having an IT grade from 9 to 16 inclusive and a size over 3 mm. For these, the fundamental deviation is zero.

A second exception occurs for holes J, K, M, and N up to grade IT8 inclusive and holes P through ZC up to grade 7 inclusive for sizes over 3 mm. For these, the upper deviation of the hole is equal to the negative of the lower deviation of the shaft plus the change in tolerance of that grade and the next finer grade. In equation form, this can be written

Upper deviation (hole)

$$= -\text{lower deviation (shaft)} + \text{IT (shaft)} - \text{IT (next finer shaft)} \tag{27.4}$$

TABLE 27.4 Coefficients for Use in Eq. (27.3) to Compute the Fundamental Deviations for Shafts†

Fundamental deviation	α	β	γ	Notes
a	-0.265	-1.3	1	$D \leq 120$
	0	-3.5	1	$D > 120$
b	-0.140	-0.85	1	$D \leq 160$
	0	-1.8	1	$D > 160$
c	0	-5.2	0.2	$D \leq 40$
	-0.095	-0.8	1	$D > 40$
cd				$cd = (c \cdot d)^{1/2}$
d	0	-16	0.44	
e	0	-11	0.41	
ef				$ef = (e \cdot f)^{1/2}$
f	0	-5.5	0.41	
fg				$fg = (f \cdot g)^{1/2}$
g	0	-2.5	0.34	
h	0	0	0	
j				No formula
js				$js = IT/2$
k	0	0.6	0.33	$IT4$ to $IT7$, $D \leq 500$
	0	0	0	$IT8$ to $IT16$, $D > 500$
m	$IT7/1000$	- $IT6$	0	$D \leq 500$
	0.013	0.024	1	$D > 500$
n	0	5	0.34	$D \leq 500$
	0.021	0.04	1	$D > 500$
p	$IT7$	2	0	$D \leq 500$
	0.038	0.072	D	$D > 500$
r				$r = (p \cdot s)^{1/2}$
s	$IT8$	2	0	$D \leq 50$
	$IT7$	0.4	1	$D > 50$
t	$IT7$	0.63	1	
u	$IT7$	1	1	
v	$IT7$	1.25	1	
x	$IT7$	1.6	1	
y	$IT7$	2	1	
z	$IT7$	2.5	1	
za	$IT8$	3.15	1	
zb	$IT9$	4	1	
zc	$IT10$	5	1	

†These coefficients will give results that may not conform exactly to the fundamental deviations tabulated in the standards. Use the standards if exact conformance is required.
SOURCE: From Ref. [27.2].

TABLE 27.5 Preferred Fits

Type	Hole basis	Shaft basis†	Name and application
Clearance	H11/c11	C11/h11	<i>Loose-running fit</i> for wide commercial tolerances or allowances on external members
	H9/d9	D9/h9	<i>Free-running fit</i> not for use where accuracy is essential, but good for large temperature variations, high running speeds, or heavy journal pressures
	H8/f7	F8/h7	<i>Close-running fit</i> for running on accurate machines and for accurate location at moderate speeds and journal pressures
	H7/g6	G7/h6	<i>Sliding fit</i> not intended to run freely, but to move and turn freely and locate accurately
	H7/h6	H7/h6	<i>Locational-clearance fit</i> provides snug fit for locating stationary parts, but can be freely assembled and disassembled
Transition	H7/k6	K7/h6	<i>Locational-transition fit</i> for accurate location, a compromise between clearance and interference
	H7/n6	N7/h6	<i>Locational-transition fit</i> for more accurate location where greater interference is permissible
Interference	H7/p6	P7/h6	<i>Locational-interference fit</i> for parts requiring rigidity and alignment with prime accuracy of location but without special bore pressure requirements
	H7/s6	S7/h6	<i>Medium-drive fit</i> for ordinary steel parts or shrink fits on light sections, the tightest fit usable with cast iron
	H7/u6	U7/h6	<i>Force fit</i> suitable for parts which can be highly stressed or for shrink fits where the heavy pressing forces required are impracticable

†The transition and interference shaft-basis fits shown do not convert to exactly the same hole-basis fit conditions for basic sizes from 0 to 3 mm. Interference fit P7/h6 converts to a transition fit H7/p6 in the size range 0 to 3 mm.

SOURCE: From Ref. [27.2].

27.2.4 Preferred Fits

Table 27.5 lists the preferred fits for most common applications. Either first or second choices from Table 27.3 should be used for the basic sizes.

Example 1. Using the shaft-basis system, find the limits for both members using a basic size of 25 mm and a free-running fit.

Solution. From Table 27.5, we find the fit symbol as D9/h9, the same as Fig. 27.2. Table 27.1 gives $D_{\min} = 18$ and $D_{\max} = 30$ for a basic size of 25. Using Eq. (27.2), we find

$$D = \sqrt{D_{\max}D_{\min}} = \sqrt{30(18)} = 23.2 \text{ mm}$$

Then, from Eq. (27.1) and Table 27.2,

$$\begin{aligned} 40i &= \frac{40}{1000} (0.45D^{1/3} + 0.001D) \\ &= \frac{40}{1000} [0.45(23.2)^{1/3} + 0.001(23.2)] = 0.052 \text{ mm} \end{aligned}$$

This is the IT9 tolerance grade for the size range 18 to 30 mm.

We proceed next to find the limits on the 25D9 hole. From Table 27.4, for a d shaft, we find $\alpha = 0$, $\beta = -16$, and $\gamma = 0.44$. Therefore, using Eq. (19.3), we find the fundamental deviation for a d shaft to be

$$\begin{aligned} \text{Fundamental deviation} &= \alpha + \frac{\beta D^\gamma}{1000} = 0 + \frac{-16(23.2)^{0.44}}{1000} \\ &= -0.064 \text{ mm} \end{aligned}$$

But this is also the upper deviation for a d shaft. Therefore, for a D hole, we have

$$\begin{aligned} \text{Lower deviation (hole)} &= -\text{upper deviation (shaft)} \\ &= -(-0.064) = 0.064 \text{ mm} \end{aligned}$$

The upper deviation for the hole is the sum of the lower deviation and the IT grade. Thus

$$\text{Upper deviation (hole)} = 0.064 + 0.052 = 0.116 \text{ mm}$$

The two limits of the hole dimensions are therefore

$$\begin{aligned} \text{Upper limit} &= 25 + 0.116 = 25.116 \text{ mm} \\ \text{Lower limit} &= 25 + 0.064 = 25.064 \text{ mm} \end{aligned}$$

For the h shaft, we find from Table 19.4 that $\alpha = \beta = \gamma = 0$. Therefore, the fundamental deviation, which is the same as the upper deviation, is zero. The lower deviation equals the upper deviation minus the tolerance grade, or

$$\text{Lower deviation (shaft)} = 0 - 0.052 = -0.052 \text{ mm}$$

Therefore, the shaft limits are

$$\begin{aligned} \text{Upper limit} &= 25 + 0 = 25.000 \text{ mm} \\ \text{Lower limit} &= 25 - 0.052 = 24.948 \text{ mm} \end{aligned}$$

27.3 U.S. STANDARD—INCH UNITS

The fits described in this section are all on a *unilateral hole basis*. The kind of fit obtained for any one class will be similar throughout the range of sizes. Table 27.6 describes the various fit designations. Three classes, RC9, LC10, and LC11, are described in the standards [27.1] but are not included here. These standards include recommendations for fits up to a basic size of 200 in. However, the tables included here are valid only for sizes up to 19.69 in; this is in accordance with the American-British-Canadian (ABC) recommendations.

The coefficients listed in Table 27.7 are to be used in the equation

$$L = CD^{1/3} \tag{27.5}$$

where L is the limit in thousandths of an inch corresponding to the coefficient C and the basic size D in inches. The resulting four values of L are then summed algebraically to the basic hole size to obtain the four limiting dimensions.

It is emphasized again that the limits obtained by the use of these equations and tables are only close approximations to the standards.

27.4 INTERFERENCE-FIT STRESSES

The assembly of two cylindrical parts by press-fitting or shrinking one member onto another creates a contact pressure between the two members. The stresses resulting from the interference fit can be computed when the contact pressure is known. This pressure may be obtained from Eq. (2.67) of Ref. [27.3]. The result is

$$p = \frac{\delta}{bA} \tag{27.6}$$

where δ = radial interference and A is given by

$$A = \frac{1}{E_i} \left(\frac{b^2 + a^2}{b^2 - a^2} - \nu_i \right) + \frac{1}{E_o} \left(\frac{c^2 + b^2}{c^2 - b^2} + \nu_o \right) \tag{27.7}$$

The dimensions a , b , and c are the radii of the members, as shown in Fig. 27.3. The terms E_i and E_o are the elastic moduli for the inner and outer cylinders, respectively. If the inner cylinder is solid, then $a = 0$ and Eq. (27.7) becomes

$$A = \frac{1}{E_i} (1 - \nu_i) + \frac{1}{E_o} \left(\frac{c^2 + b^2}{c^2 - b^2} + \nu_o \right) \tag{27.8}$$

Sometimes the mating parts have identical moduli. In this case, Eq. (27.6) becomes

$$p = \frac{E\delta}{b} \left[\frac{(c^2 - b^2)(b^2 - a^2)}{2b^2(c^2 - a^2)} \right] \tag{27.9}$$

This equation simplifies still more if the inner cylinder is solid. We then have

$$p = \frac{E\delta}{2bc^2} (c^2 - b^2) \tag{27.10}$$

TABLE 27.6 Standard Fits

Designation	Name and application
RC1	<i>Close sliding fits</i> are intended for the accurate location of parts which must be assembled without perceptible play.
RC2	<i>Sliding fits</i> are intended for accurate location, but with greater maximum clearance than an RC1 fit.
RC3	<i>Precision running fits</i> are about the loosest fits which can be expected to run freely and are intended for precision work at slow speeds and light journal pressures but are not suitable where appreciable temperature differences are likely.
RC4	<i>Close-running fits</i> are intended chiefly for running fits on accurate machinery with moderate surface speeds and journal pressure, where accurate location and minimum play are desired.
RC5	<i>Medium-running fits</i> are intended for higher running speeds or heavy journal pressures, or both.
RC6	<i>Medium-running fits</i> are intended for applications where more play than RC5 is required.
RC7	<i>Free-running fits</i> are intended for use where accuracy is not essential or where large temperature variations are likely, or both.
RC8	<i>Loose-running fits</i> are intended for use where wide commercial tolerances may be necessary, together with an allowance, on the hole.
LC1 to LC9	<i>Locational-clearance fits</i> are intended for parts which are normally stationary, but which can be freely assembled or disassembled. Snug fits are for parts requiring accuracy of location. Medium fits are for parts such as ball, race, and housings. The looser fastener fits are needed where freedom of assembly is of first importance.
LT1 to LT6	<i>Locational-transitional fits</i> are a compromise between clearance and interference fits for application where accuracy of location is important but either a small amount of clearance or interference is permissible.
LN1 to LN3	<i>Locational-interference fits</i> are used where accuracy of location is of prime importance and for parts requiring rigidity and alignment with no special requirements for bore pressure. These fits are not intended for parts that must transmit frictional loads to one another.
FN1	<i>Light-drive fits</i> are those requiring light assembly pressures and produce more or less permanent assemblies. They are suitable for thin sections or long fits or in cast-iron external members.
FN2	<i>Medium-drive fits</i> are suitable for ordinary steel parts or for shrink fits on light sections. They are about the tightest fits that can be used with high-grade cast-iron external members.
FN3	<i>Heavy-drive fits</i> are suitable for heavier steel parts or for shrink fits in medium sections.
FN4 and FN5	<i>Force fits</i> are suitable for parts which can be highly stressed or for shrink fits where the heavy pressing forces required are impractical.

The maximum stresses occur at the contact surface. Here the stresses are biaxial, if the longitudinal direction is neglected, and for the outer member are given in Ref. [27.3] as

$$\sigma_{ot} = p \frac{c^2 + b^2}{c^2 - b^2} \quad \sigma_{or} = -p \quad (27.11)$$

TABLE 27.7 Coefficients *C* for Use in Eq. (27.5)

Class of fit	Hole limits		Shaft limits	
	Lower	Upper	Lower	Upper
RC1	0	+0.392	-0.588	-0.308
RC2	0	+0.571	-0.700	-0.308
RC3	0	+0.907	-1.542	-0.971
RC4	0	+1.413	-1.879	-0.971
RC5	0	+1.413	-2.840	-1.932
RC6	0	+2.278	-3.345	-1.932
RC7	0	+2.278	-4.631	-3.218
RC8	0	+3.570	-7.531	-5.253
LC1	0	+0.571	-0.392	0
LC2	0	+0.907	-0.571	0
LC3	0	+1.413	-0.907	0
LC4	0	+3.570	-2.278	0
LC5	0	+0.907	-0.879	-0.308
LC6	0	+2.278	-2.384	-0.971
LC7	0	+3.570	-4.211	-1.933
LC8	0	+3.570	-5.496	-3.218
LC9	0	+5.697	-8.823	-5.253
LT1	0	+0.907	-0.281	+0.290
LT2	0	+1.413	-0.442	+0.465
LT3†	0	+0.907	+0.083	+0.654
LT4†	0	+1.413	+0.083	+0.990
LT5	0	+0.907	+0.656	+1.227
LT6	0	+0.907	+0.656	+1.563
LN1	0	+0.571	+0.656	+1.048
LN2	0	+0.907	+0.994	+1.565
LN3	0	+0.907	+1.582	+2.153
FN1	0	+0.571	+1.660	+2.052
FN2	0	+0.907	+2.717	+3.288
FN3‡	0	+0.907	+3.739	+4.310
FN4	0	+0.907	+5.440	+6.011
FN5	0	+1.413	+7.701	+8.608

†Not for sizes under 0.24 in.

‡Not for sizes under 0.95 in.

where *t* and *r* designate the tangential and radial directions, respectively.

For the inner member, the stresses at the contact surface are

$$\sigma_{ir} = -p \frac{b^2 + a^2}{b^2 - a^2} \quad \sigma_{it} = -p \tag{27.12}$$

A stress-concentration factor may be needed for certain situations. A hub press-fitted to a shaft, for example, would be likely to have an increased pressure at the ends. So if either a brittle fracture or a fatigue failure is a possibility, then for such cases a stress-concentration factor in the range from 1.5 to 2 should be used.

Example 2. A 1½-in solid-steel shaft is fitted to a steel forging having an outside diameter of 2½ in using a class FN3 fit. Determine the worst-condition stresses for each member.

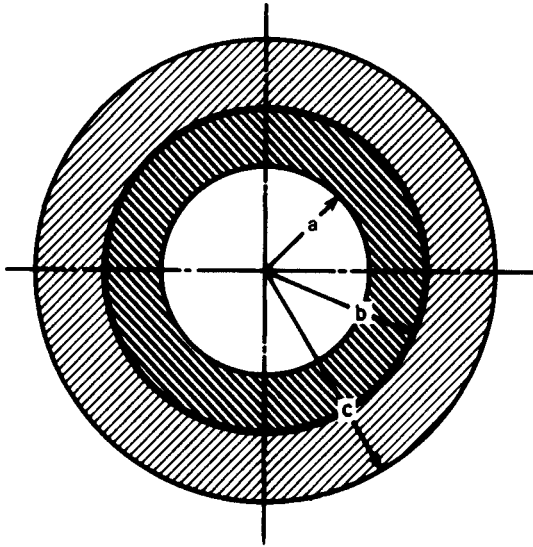

FIGURE 27.3 A press-fitted assembly. Inner member has hole of radius a . Contact surface has radius b . Outer member has outside radius c .

Solution. The worst condition would occur when the hole is minimum and the shaft is maximum. From Table 27.7, we find $C = 0$ and $C = +4.310$ for the lower limit of the hole and upper limit of the shaft, respectively. Using Eq. (27.5), we find

$$L = CD^{1/3} = \frac{+4.310(1.5)^{1/3}}{1000} = 0.0049 \text{ in}$$

Therefore, the maximum shaft has a diameter $d_i = 1.5 + 0.0049 = 1.5049$ in. Similarly, the minimum hole is $d_o = 1.5000$ in. The radial interference is $\delta = 0.5(0.0049) = 0.00245$ in. For use in Eq. (27.10), we observe that $b = 0.75$ in and $c = 1.25$ in based on the nominal dimensions. Using $E = 30$ Mpsi, we find the contact pressure to be

$$\begin{aligned} p &= \frac{E\delta}{bc^2} (c^2 - b^2) \\ &= \frac{30(10)^6(0.00245)}{0.75(1.25)^2} [(1.25)^2 - (0.75)^2] \\ &= 62.7 \text{ kpsi} \end{aligned}$$

Using Eq. (27.11) to get the stresses in the outer member gives

$$\begin{aligned} \sigma_{or} &= p \frac{c^2 + b^2}{c^2 - b^2} = 62.7 \left[\frac{(1.25)^2 + (0.75)^2}{(1.25)^2 - (0.75)^2} \right] = 133.2 \text{ kpsi} \\ \sigma_{ot} &= -p = -62.7 \text{ kpsi} \end{aligned}$$

For the inner member, the worst stress is given by

$$\sigma_{it} = \frac{-pb^2}{b^2 - a^2} = -p = -62.7 \text{ kpsi}$$

and the result is

$$\sigma_{ir} = \sigma_{it} = -62.7 \text{ kpsi}$$

27.5 ABSOLUTE TOLERANCES†

When an aggregate of several parts is assembled, the gap, grip, or interference is related to dimensions and tolerances of the individual parts. Consider an array of parallel vectors as depicted in Fig. 27.4, the x 's directed to the right and the y 's directed to the left. They may be treated as scalars and represented algebraically. Let t_i be the bilateral tolerance on \bar{x}_i and t_j be the bilateral tolerance on \bar{y}_j , all being positive numbers. The gap remaining short of closure is called w and may be viewed as the slack variable permitting summation to zero. Thus,

$$(x_1 + x_3 + \dots) - (y_2 + y_4 + \dots) - w = 0$$

or

$$w = \Sigma x_i - \Sigma y_j \tag{27.13}$$

The largest gap w exists when the right-tending vectors are the largest possible and the left-tending vectors are the smallest possible. Expressing Eq. (19.13) in terms of the greatest deviations from the means gives

$$w_{\max} = \Sigma(\bar{x}_i + t_i) - \Sigma(\bar{y}_j - t_j) = \Sigma\bar{x}_i - \Sigma\bar{y}_j + \sum_{\text{all}} t \tag{27.14}$$

† See Ref. [27.4].

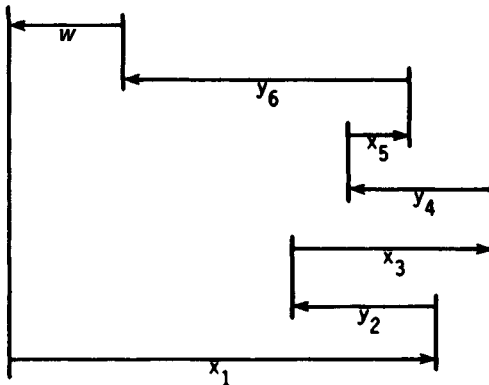

FIGURE 27.4 An array of parallel vectors.

Similarly, for the smallest gap,

$$w_{\min} = \Sigma(\bar{x}_i - t_i) - \Sigma(\bar{y}_j + t_j) = \Sigma\bar{x}_i - \Sigma\bar{y}_j - \sum_{\text{all}} t \tag{27.15}$$

The mean of w is

$$\bar{w} = \frac{1}{2}(z_{\max} + z_{\min}) = \frac{1}{2}[(\Sigma\bar{x}_i - \Sigma\bar{y}_j + \Sigma t) + (\Sigma\bar{x}_i - \Sigma\bar{y}_j - \Sigma t)] \tag{27.16}$$

$$\bar{w} = \Sigma\bar{x}_i - \Sigma\bar{y}_j$$

The bilateral tolerance of w is

$$t_w = \frac{1}{2}(w_{\max} - w_{\min}) = \frac{1}{2}[(\Sigma\bar{x}_i - \Sigma\bar{y}_j + \Sigma t) - (\Sigma\bar{x}_i - \Sigma\bar{y}_j - \Sigma t)] \tag{27.17}$$

$$t_w = \sum_{\text{all}} t$$

Equation (27.15) gives rise to expressions such as “the stacking of tolerances” in describing the conditions at the gap. All the bilateral tolerances of the constituent x ’s and y ’s add to the tolerance of the gap. If the gap is an interference, then w is a right-tending vector (negative). For all instances to be interference fits, both w_{\max} and w_{\min} have to be negative.

Example 3. In the pin-washer-snap-ring assembly depicted in Fig. 27.5, identify the mean gap \bar{w} , gap tolerance t_w , maximum gap w_{\max} , and minimum gap w_{\min} if $x_1 = 1.385 \pm 0.005$, $y_2 = 0.125 \pm 0.001$, $y_3 = 1.000 \pm 0.002$, and $y_4 = 0.250 \pm 0.001$ in.

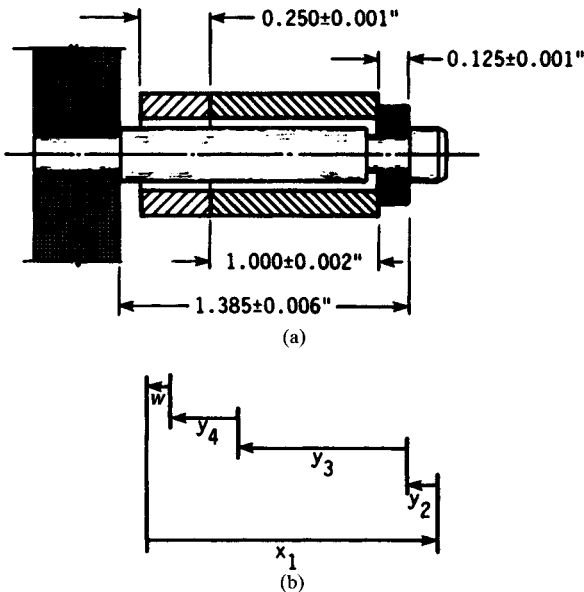

FIGURE 27.5 (a) A pin-washer-snap-ring assembly and associated gap; (b) parallel vectors describing gap.

Solution. From Eq. (27.16),

$$\bar{w} = \Sigma x_i - \Sigma y_j = 1.385 - 0.125 - 1.000 - 0.250 = 0.010 \text{ in}$$

From Eq. (27.17), $t_w = \sum_{\text{all}} t = 0.005 + 0.001 + 0.002 + 0.001 = 0.009 \text{ in}$

From Eq. (27.14), $w_{\text{max}} = \bar{w} + t_w = 0.010 + 0.009 = 0.019 \text{ in}$

From Eq. (27.15), $w_{\text{min}} = \bar{w} - t_w = 0.010 - 0.009 = 0.001 \text{ in}$

All instances of the gap w are positive, and therefore noninterfering.

Example 4. In Example 3, the washer, sleeve, and snap ring are vendor-supplied parts, and the pin is machined in-house. To assure a noninterfering assembly, what should the pin tolerance t_1 be?

Solution. From Eq. (27.16),

$$\bar{w} = \Sigma x_i - \Sigma y_j = 1.385 - 0.125 - 1.000 - 0.250 = 0.010 \text{ in}$$

From Eq. (27.17), $t_w = \sum_{\text{all}} t = t_1 + 0.001 + 0.002 + 0.001 = t_1 + 0.004$

$$t_1 = t_w - 0.004$$

As long as $t_w \leq \bar{w}$ —that is, $t_w \leq 0.010 \text{ in}$ —there will be a gap.

$$t_w = t_1 + 0.004 \leq 0.010$$

$$t_1 \leq 0.006 \text{ in}$$

If t_1 cannot be economically maintained at 0.006 or less, but may be 0.007 in or more, then there will be instances of interference, unless

1. Vendors can reduce the tolerance on the washer, spacer, and snap ring.
2. Inspection and selective assembly are acceptable.
3. Some interference, when detected, is solved by selective assembly for some parts, or scrapping.

Important to alternatives 2 and 3 is a prediction of the chance of encountering an interference fit.

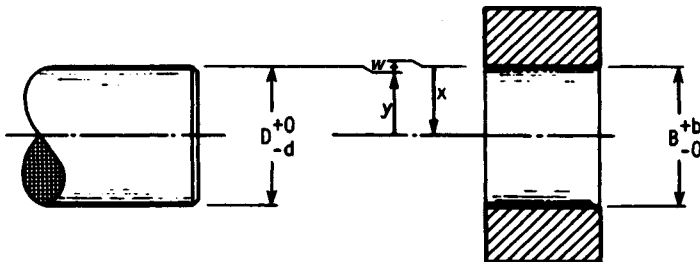

FIGURE 27.6 A journal-bushing assembly with unilateral tolerances.

TABLE 27.8 Absolute Tolerance Worksheet

i	t	x_i	y_i
1	0.006	1.385	
2	0.001		0.125
3	0.002		1.000
4	0.001		0.250
	$\Sigma = 0.010$	1.385	1.375
		-1.375	
		$\bar{w} = 0.010$	

Example 5. Figure 27.6 shows a journal-bushing assembly with unilateral tolerances. What is the description of the radial clearances resulting from these specifications?

Solution. From Eq. (27.14),

$$\begin{aligned}\bar{w} = \bar{c} &= \Sigma x_i - \Sigma y_j = \left(\frac{B}{2} + \frac{b}{4}\right) - \left(\frac{D}{2} + \frac{d}{4}\right) \\ &= \frac{B-D}{2} + \frac{b+d}{4}\end{aligned}\quad (27.18)$$

From Eq. (27.17),

$$t_w = \sum_{\text{all}} t = \frac{b}{4} + \frac{d}{4}\quad (27.19)$$

From Eq. (27.14),

$$\begin{aligned}w_{\max} = c_{\max} &= \bar{w} + t_w = \left(\frac{B-D}{2} + \frac{b+d}{4}\right) \\ &+ \frac{b+d}{4} = \frac{B-D}{2} + \frac{b+d}{2}\end{aligned}\quad (27.20)$$

From Eq. (27.15),

$$\begin{aligned}w_{\min} = c_{\min} &= \bar{w} - t_w = \left(\frac{B-D}{2} + \frac{b+d}{4}\right) \\ &- \frac{b+d}{4} = \frac{B-D}{2}\end{aligned}\quad (27.21)$$

Table 27.8 is an absolute tolerance worksheet, a convenient nonalgebraic form suitable to the manufacturing floor.

REFERENCES

- 27.1 "Preferred Limits and Fits for Cylindrical Parts," ANSI B4.1-1967 (R1999).[†]
 27.2 "Preferred Metric Limits and Fits," ANSI B4.2-1978 (R1999).

[†] The symbol R indicates that the standard has been reaffirmed as up-to-date.

- 27.3 Joseph E. Shigley and Charles R. Mischke, *Mechanical Engineering Design*, 5th ed., McGraw-Hill, New York, 1989.
- 27.4 M. F. Spotts, *Dimensioning and Tolerancing for Quality Production*, Prentice-Hall, Englewood Cliffs, N.J., 1983. (Excellent bibliography on standards and handbooks, dimensioning and tolerancing, quality control, gauging and shop practice, probability and statistics.)