

[bookboon.com](http://bookboon.com)

# Fluid Mechanics and the Theory of Flight

R.S. Johnson



Download free books at

[bookboon.com](http://bookboon.com)

R.S. Johnson

# Fluid Mechanics and the Theory of Flight

---

Fluid Mechanics and the Theory of Flight  
© 2012 R.S. Johnson & Ventus Publishing ApS  
ISBN 978-87-7681-975-0

# Contents

	<b>Preface</b>	<b>7</b>
<b>1</b>	<b>Introduction and Basics</b>	<b>8</b>
1.1	The continuum hypothesis	9
1.2	Streamlines and particle paths	10
1.3	The material (or convective) derivative	14
1.4	The equation of mass conservation	18
1.5	Pressure and hydrostatic equilibrium	23
1.6	Euler's equation of motion (1755)	25
	Exercises 1	29
<b>2</b>	<b>Equations: Properties and Solutions</b>	<b>38</b>
2.1	The vorticity vector and irrotational flow	38
2.2	Helmholtz's equation (the 'vorticity' equation)	42
2.3	Bernoulli's equation (or theorem)	44
2.4	The pressure equation	48
2.5	Vorticity and circulation	52
2.6	The stream function	56
2.7	Kinetic energy and a uniqueness theorem	59
	Exercises 2	61

## Teach with the Best. Learn with the Best.

Agilent offers a wide variety of affordable, industry-leading electronic test equipment as well as knowledge-rich, on-line resources—for professors and students.

We have 100's of comprehensive web-based teaching tools, lab experiments, application notes, brochures, DVDs/CDs, posters, and more.



**See what Agilent can do for you.**  
[www.agilent.com/find/EDUstudents](http://www.agilent.com/find/EDUstudents)  
[www.agilent.com/find/EDUeducators](http://www.agilent.com/find/EDUeducators)

© Agilent Technologies, Inc. 2012 u.s. 1-800-829-4444    canada: 1-877-894-4414

Anticipate — Accelerate — Achieve



**Agilent Technologies**



<b>3</b>	<b>Viscous Fluids</b>	<b>67</b>
3.1	The Navier-Stokes equation	67
3.2	Simple exact solutions	68
3.3	The Reynolds number	75
3.4	The (2D) boundary-layer equations	77
3.5	The flat-plate boundary layer	81
	Exercises 3	84
<b>4</b>	<b>Two dimensional, incompressible, irrotational flow</b>	<b>88</b>
4.1	Laplace's equation	88
4.2	The complex potential	90
4.3	Simple (steady) two-dimensional flows	91
4.4	The method of images	109
4.5	The circle theorem (Milne-Thomson, 1940)	113
4.6	Uniform flow past a circle	116
4.7	Uniform flow past a spinning circle (circular cylinder)	119
4.8	Forces on objects (Blasius' theorem, 1910)	121
4.9	Conformal transformations	128
4.10	The transformation of flows	131
	Exercises 4	134



Find and follow us: <http://twitter.com/bioradlscareers>  
[www.linkedin.com/groupsDirectory](http://www.linkedin.com/groupsDirectory), search for Bio-Rad Life Sciences Careers  
<http://bio-radlifesciencescareersblog.blogspot.com>



**Your Profession is Your Passion. Pass it On.**

John Randall, PhD  
Senior Marketing Manager, Bio-Plex Business Unit

Bio-Rad is a longtime leader in the life science research industry and has been voted one of the Best Places to Work by our employees in the San Francisco Bay Area. Bring out your best in one of our many positions in research and development, sales, marketing, operations, and software development. Opportunities await — share your passion at Bio-Rad!

[www.bio-rad.com/careers](http://www.bio-rad.com/careers)

**BIO-RAD**



<b>5</b>	<b>Aerofoil Theory</b>	<b>140</b>
5.1	Transformation of circles	141
5.2	The flat-plate aerofoil	148
5.3	The flat-plate aerofoil with circulation	153
5.4	The general Joukowski aerofoil in a flow	159
	Exercises 5	163
	<b>Appendixes</b>	<b>165</b>
	Appendix 1: Biographical Notes	165
	Appendix 2: Check-list of basic equations	184
	Appendix 3: Derivation of Euler's equation (which describes an inviscid fluid)	186
	Appendix 4: Kelvin's circulation theorem (1869)	189
	Appendix 5: Some Joukowski aerofoils	190
	Appendix 6: Lift on a flat-plate aerofoil	191
	Appendix 7: MAPLE program for plotting Joukowski aerofoils	193
	<b>Answers</b>	<b>194</b>
	<b>Index</b>	<b>209</b>



ericsson.  
com

#### Shaping tomorrow's world – today

Our business is at the heart of a connected world – a world where communication is empowering people, business and society. Our networks, telecom services and multimedia solutions are shaping tomorrow. And this might just be your chance to shape your own future.

#### It's a people thing

We are looking for high-caliber people who can see the opportunities, people who can bring knowledge, energy and vision to our organization. In return we offer the chance to work with cutting-edge technology, personal and professional development, and the opportunity to make a difference in a truly global company.

We are currently recruiting both new graduates and experienced professionals in four areas: **Software, Hardware, Systems and Integration & Verification.**

Are you ready to shape your future? Begin by exploring a career with Ericsson. Visit [www.ericsson.com/join-ericsson](http://www.ericsson.com/join-ericsson)



# Preface

This text is based on lecture courses given by the author, over about 40 years, at Newcastle University, to final-year applied mathematics students. It has been written to provide a typical course that introduces the majority of the relevant ideas, concepts and techniques, rather than a wide-ranging and more general text. Thus the topics, with their detailed discussion linked to the many carefully worked examples, do not cover as broad a spectrum as might be found in other, more wide-ranging texts on fluid mechanics; this is a quite deliberate choice here. Thus the development follows that of a conventional introductory module on fluids, comprising a basic introduction to the main ideas of fluid mechanics, culminating in a presentation of complex-variable techniques and classical aerofoil theory. (There are many routes that could be followed, based on a general introduction to the fundamentals of the theory of fluid mechanics. For example, the course could then specialise in viscous flow, or turbulence, or hydrodynamic stability, or gas dynamics and supersonic flow, or water waves, to mention just a few; we opt for the use of the complex potential to model flows, with special application to simple aerofoil theory.) The material, and its style of presentation, have been selected after many years of development and experience, resulting in something that works well in the lecture theatre. Thus, for example, some of the more technical aspects are set aside (but usually discussed in an Appendix).

It is assumed that the readers are familiar with the vector calculus, methods for solving ordinary and partial differential equations, and complex-variable theory. Nevertheless, with this general background, the material should be accessible to mathematicians, physicists and engineers. The numerous worked examples are to be used in conjunction with the large number of set exercises – there are over 100 – for which the answers are provided. In addition, there are some appendices that contain further relevant material, together with some detailed derivations; a list of brief biographies of the various contributors to the ideas presented here is also provided.

Where appropriate, suitable figures and diagrams have been included, in order to aid the understanding – and to see the relevance – of much of the material. However, the interested reader is advised to make use of the web, for example, to find pictures and movies of the various phenomena that we mention.

# 1 Introduction and Basics

We start with a working definition: a fluid is a material that cannot, in general, withstand any force without change of shape. (An exception is the special problem of a uniform – inward – pressure acting on a liquid, which is a fluid that cannot be compressed, so there is no change of volume.) This property of a fluid should be compared with what happens to a solid: this can withstand a force, without any appreciable change of shape or volume – until it fractures!

We take this fundamental and defining property as the starting point for a simple classification of materials, and fluids in particular:

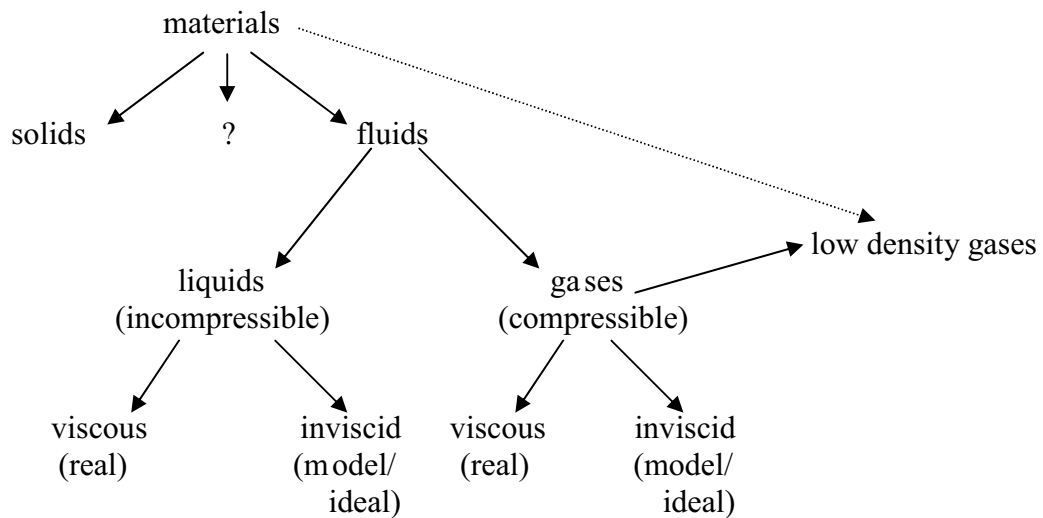

(Some materials sit somewhere between solids and fluids; these are usually called *thixotropic* materials – non-drip paints are an example.)

We are interested in fluids, of which there are two main types exemplified by: air – a *gas* – which is easily compressed (until it liquefies), whereas water – a *liquid* – is virtually incompressible. (The density of water increases by about 0.5% under a pressure of 100 atmospheres.)

All conventional fluids are viscous; simply observe the various phenomena associated with the stirred motion of a drink in a cup; e.g. after stirring, the motion eventually comes to a halt; also, during the motion, the particles of fluid directly in contact with the inner surface of the cup are stationary.

In this study, we will eventually work, mainly, with a model fluid that is incompressible. This applies even to air – relevant to the theory of flight – provided that the speeds are less than about 300mph (which is certainly the situation at take off and landing). The rôle of viscosity is important in aerofoil theory, and will therefore be discussed carefully, but it turns out that the *details* of viscous flow are not significant for flight.

## 1.1 The continuum hypothesis

The first task is to introduce a suitable, general description of a fluid, and then to develop an appropriate (mathematical) representation of it. This involves regarding the body of fluid on the large (macroscopic) scale i.e. consistent with the familiar observation that fluid – air or water, for example – appears to fill completely the region of space that it occupies: we ignore the existence of molecules and the ‘gaps’ between them (which would constitute a microscopic or molecular model). This crucial idealisation, which regards the fluid as *continuously distributed* throughout a region of space, is called the *continuum hypothesis*.

Now, at every point (particle), we may define a set of functions that describe the properties of the fluid at that point:

$\mathbf{u}(\mathbf{x}, t)$  – the velocity vector (a vector field)

$p(\mathbf{x}, t)$  – the pressure (a scalar field)

$\rho(\mathbf{x}, t)$  – the density (*ditto*),

where  $\mathbf{x} = (x, y, z)$  is the position vector (expressed in rectangular Cartesian coordinates, but other coordinate systems may sometimes be required). Here,  $t$  is time and we usually write  $\mathbf{u} = (u, v, w)$ , although there may be situations where the components are more conveniently written as  $x_i$  and  $u_i$  ( $i = 1, 2, 3$ ). Note that both  $p$  and  $\rho$  are defined at a point, with no preferred orientation: they are *isotropic*. Also, we have not included temperature, the variations of which may be important for a gas (requiring a consideration of thermodynamics and the introduction of thermal energy). We will mention temperature only as a consequence of other properties e.g. pressure and density implies a certain temperature, via some *equation of state*. We assume, for our discussion here, that all the motion occurs at fixed temperature throughout the fluid, or that heat transfer between regions of different temperature can be ignored (e.g. it occurs on timescales far longer than those associated with the flow under consideration).

In our initial considerations, we shall allow the density to vary, but we will soon revert to the appropriate choice for our incompressible (model) fluid:  $\rho = \text{constant}$ . Further, the three functions introduced above are certainly to be continuous in both  $\mathbf{x}$  and  $t$  for any reasonable representation of a physically realistic flow.

**Note:** This description, which defines the properties of the fluid at any point, at any time – the most common one in use – is called the *Eulerian* description. The alternative is to follow a particular point (particle) as it moves in the fluid, and then determine how the properties change on this particle; this is the *Lagrangian* description. We shall write more of these alternatives later.

---

We are now in a position to introduce two different ways of describing the general nature of the motion in a given velocity field which represents a fluid flow.

## 1.2 Streamlines and particle paths

We assume that we are given the velocity field  $\mathbf{u}(\mathbf{x}, t)$  (and how any particular motion is generated or maintained is, for the moment, altogether irrelevant); the existence of a motion is the sole basis for the following descriptions.

**1.2.1** A **streamline** is an imaginary line in the fluid which everywhere has the velocity vector as its tangent, at any instant in time.

Let such a curve be parameterised by  $s$ , and write the curve as  $\mathbf{x} = \mathbf{X}(s, t)$ ; we give a reminder of the underlying idea that we now use.

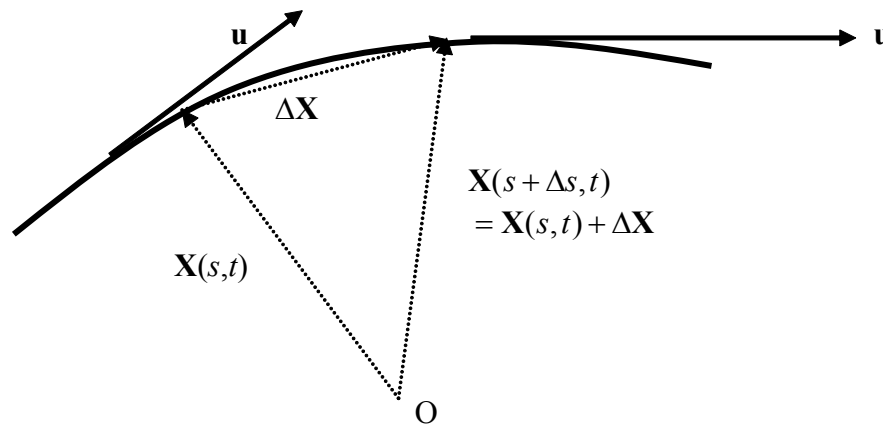

We form  $\frac{\mathbf{X}(s + \Delta s, t) - \mathbf{X}(s, t)}{\Delta s} = \frac{\Delta \mathbf{X}}{\Delta s}$ , so that, in the limit  $\Delta s \rightarrow 0$ , the derivative  $\frac{d\mathbf{X}}{ds}$  is the tangent to the curve  $\mathbf{x} = \mathbf{X}(s, t)$  - a familiar result. Thus our definition of a streamline can be expressed as

$$\frac{d\mathbf{X}}{ds} \propto \mathbf{u} \text{ or } \frac{d\mathbf{X}}{ds} = k\mathbf{u} \text{ or } \frac{d\mathbf{X}}{ds} = \mathbf{u}(\mathbf{X}, t),$$

when we redefine  $s$ . In Cartesian components, this is the set of three coupled, ordinary differential equations

$$\frac{dx}{ds} = u, \frac{dy}{ds} = v, \frac{dz}{ds} = w \text{ (all at fixed } t)$$

or, more conveniently, a pair of equations e.g.

$$\frac{dy}{dx} = \frac{v}{u}, \frac{dz}{dx} = \frac{w}{u}.$$

This set is often expressed in the symmetric form  $\frac{dx}{u} = \frac{dy}{v} = \frac{dz}{w}$ .

Note that, in 2-space  $(x, y)$ , we simply have

$$\frac{dy}{dx} = \frac{v}{u}$$

(because there is no variation, and no flow, in the  $z$ -direction).

### **Example 1**

*Streamlines.* Find the streamlines for the flow  $\mathbf{u} \equiv (\alpha xt, -\alpha y, 0)$ , where  $\alpha > 0$  is a constant, and that family at the instant  $t = 1$ .

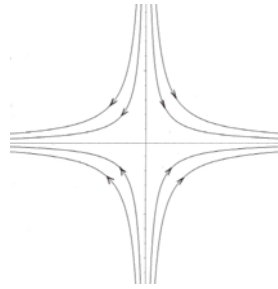

We have (in 2D)  $\frac{dy}{dx} = \frac{v}{u} = -\frac{\alpha y}{\alpha xt} = -\frac{y}{xt}$  (at fixed  $t$ ;  $x \neq 0, t \neq 0$ ), and so

$$t \int \frac{dy}{y} = -\int \frac{dx}{x} \quad \text{i.e.} \quad t \ln|y| = -\ln|x| + \text{constant}.$$

Thus  $y^t x = C$  (an arbitrary constant), and then at  $t = 1$  we have simply  $xy = C$  (a family of rectangular hyperbolae; see figure).

**Comment:** Streamlines cannot cross except, possibly, where  $\mathbf{u} = \mathbf{0}$  (defining a *stagnation point*, where the flow is stationary or stagnant) because, at such points, the direction of the zero vector is not unique.

**1.2.2 A particle path** is the path,  $\mathbf{x} = \mathbf{X}(t)$ , followed by a point (particle) as it moves in the fluid according to the given velocity vector i.e.

$$\frac{d\mathbf{X}}{dt} = \mathbf{u};$$

this is pure kinematics, determining  $\mathbf{X}(t)$  given  $\mathbf{u}(\mathbf{X}, t)$ . In component form, we have

$$\frac{dx}{dt} = u, \quad \frac{dy}{dt} = v, \quad \frac{dz}{dt} = w,$$

and here  $t$  is a *variable* (involved in the integration process).

**Example 2**

*Particle paths.* Find the particle paths for the flow  $\mathbf{u} \equiv (\alpha xt, -\alpha y, 0)$ , and that path which passes through (1,2) at .

Here we have  $\frac{dx}{dt} = \alpha xt, \frac{dy}{dt} = -\alpha y$  (and  $\frac{dz}{dt} = 0 \Rightarrow z = \text{constant}$ , so 2D); thus

$$\int \frac{dx}{x} = \alpha \int t dt; \quad \int \frac{dy}{y} = -\alpha \int dt \text{ i.e. } \ln|x| = \frac{1}{2}\alpha t^2 + \text{const.}; \quad \ln|y| = -\alpha t + \text{const.}$$

which gives  $x = Ae^{\frac{1}{2}\alpha t^2}; y = Be^{-\alpha t}$  and data at  $t = 0$  requires  $A = 1, B = 2$ . The path is therefore

$$\mathbf{x}(t) = \left( e^{\frac{1}{2}\alpha t^2}, 2e^{-\alpha t}, \text{const.} \right), \text{ when expressed in 3D.}$$

**The D. E. Shaw group is hiring.**  
**You can do the math.**

Meet us on-campus this semester.  
 Check out [www.deshaw.com](http://www.deshaw.com) for more info.



**Note:** A *steady flow* is one for which the velocity field is independent of time, and then the families of streamlines (SLs) and particle paths (PPs) necessarily coincide (because

$$\frac{d\mathbf{X}}{ds} = \mathbf{u}(\mathbf{X}) \text{ and } \frac{d\mathbf{X}}{dt} = \mathbf{u}(\mathbf{X}) \text{ each define the same set of curves.}$$

**Example 3**

*Steady flow.* All the particles (points) in a fluid move according to  $\mathbf{x} \equiv (ae^t, be^{2t}, ce^{-3t})$  (written in rect. Cart. coords.). Show that this flow field is steady, and then that the families of SLs and PPs coincide.

---

The PPs are given, and so  $\mathbf{u} = \frac{d\mathbf{x}}{dt} = (ae^t, 2be^{2t}, -3ce^{-3t})$ ; but these PPs can be expressed as  $\mathbf{x}(t) = (x(t), y(t), z(t))$ , where  $x(t) = ae^t$ , etc., and so eliminating  $a, b, c$  we obtain the velocity field  $\mathbf{u} = (x, 2y, -3z)$  for all particles (points) in the flow. This velocity field is steady.

Now the SLs are  $\frac{dx}{x} = \frac{dy}{2y} = \frac{dz}{-3z}$  and so for example – other choices are possible –

$$x^2 = Ay, y^3 z^2 = B; \text{ but the PPs give } x^2 = a^2 e^{2t} = \frac{a^2}{b} y, y^3 z^2 = b^3 e^{6t} c^2 e^{-6t} = b^3 c^2,$$

which is consistent with the representation of the SLs: the two families coincide.

---

**Example 4**

*SLs and PPs II.* The velocity components of a flow (in 2D) are  $(xye^{nt}, y) (\equiv \mathbf{u})$ , where  $t$  is time and  $n$  is a constant. Find the streamlines for this flow and the particle path which passes through (1,1) at  $t = 0$ . For what value of  $n$  will the two families of curves coincide ?

---

We have, for the PPs,  $\frac{dx}{dt} = u = xye^{nt}, \frac{dy}{dt} = v = y$ , and so we must solve the second equation first:  $\int \frac{dy}{y} = \int dt$  so  $\ln|y| = t + \text{const.}$  i.e.  $y = Ae^t = e^t$  to satisfy the initial condition. Then

$$\frac{dx}{dt} = xe^{(1+n)t} : \int \frac{dx}{x} = \int e^{(1+n)t} dt \text{ so } \ln|x| = \frac{1}{1+n} e^{(1+n)t} + \text{const.} = \frac{e^{(1+n)t} - 1}{1+n};$$

thus  $x = \exp\left[\frac{e^{(1+n)t} - 1}{1+n}\right]$ .

For the SLs:  $\frac{dy}{dx} = \frac{v}{u} = \frac{y}{xye^{nt}} = \frac{1}{xe^{nt}}$  ( $x \neq 0, y \neq 0$ ), and so

$$\int \frac{dx}{x} = e^{nt} \int dy \quad (\text{at fixed } t) \text{ i.e. } \ln|x| = ye^{nt} + \text{const. or } x = C \exp\left(ye^{nt}\right).$$

The two families coincide for steady flow i.e.  $n = 0$ .

**Comment:** In the laboratory, it is sometimes convenient to observe *streak lines*; these are all the paths through a given point, over an interval of time.

### 1.3 The material (or convective) derivative

Let us consider some (scalar) property of the fluid, labelled  $f$ ; in our representation of a fluid, this will be the pressure, or the density or a velocity component. This will, in general, vary in position and time:

$$f = f(\mathbf{x}, t).$$

We might be interested in  $\frac{\partial f}{\partial t}$ , but a more important aspect of  $f$  is how it varies in time when it is associated with a point (particle) that is moving in the fluid. So we require  $\frac{df}{dt}$  with  $\frac{d\mathbf{X}}{dt} = \mathbf{u}$ ; then we have

$$\frac{d}{dt}\{f(\mathbf{X}(t), t)\} = \frac{\partial f}{\partial t} + \left(\frac{d\mathbf{X}}{dt} \cdot \nabla\right) f = \left(\frac{\partial}{\partial t} + \mathbf{u} \cdot \nabla\right) f,$$

and this operator on  $f$  is called the *material* (or *convective*) *derivative* (because it gives the rate of change of a material point – a point or particle of the material, as it moves, or is ‘convected’, in the fluid); it is usually written as

$$\frac{D}{Dt} \equiv \frac{\partial}{\partial t} + \mathbf{u} \cdot \nabla.$$

**Warning:**

Do not think to write  $\mathbf{u} \cdot \nabla$  as  $\nabla \cdot \mathbf{u}$ ! Remember that  $\nabla$  is a differential operator and so, in the former, it operates on whatever follows the  $\nabla$ , and this is not  $\mathbf{u}$  – it is some function e.g.  $f$ .

**Note:** If we apply this operator to the velocity vector – which we might expect is the appropriate representation of the acceleration of a fluid particle – then we obtain

$$\frac{D\mathbf{u}}{Dt} = \frac{\partial\mathbf{u}}{\partial t} + (\mathbf{u} \cdot \nabla)\mathbf{u},$$

which is inherently nonlinear. That this is indeed the acceleration follows directly: we have  $\frac{d\mathbf{X}}{dt} = \mathbf{u}$  for a particle path, and so the acceleration is

$$\frac{d^2\mathbf{X}}{dt^2} = \frac{d}{dt}\mathbf{u}(\mathbf{X}(t), t) = \frac{\partial\mathbf{u}}{\partial t} + \frac{d\mathbf{X}}{dt} \cdot \nabla\mathbf{u} = \frac{D\mathbf{u}}{Dt},$$

relating the Lagrangian and Eulerian expressions.

It's only an opportunity if you act on it

IKEA.SE/STUDENT

© Inter IKEA Systems B.V. 2009



**Example 5**

*Acceleration.* Find the acceleration vector for a particle (point) which moves according to  $\mathbf{u} \equiv (\alpha x, -\alpha y)$ , in two dimensions, where  $\alpha > 0$  is a constant.

---

We have  $u = \alpha x$ ,  $v = -\alpha y$  (&  $w = 0$ ), so  $\frac{D}{Dt} \equiv \frac{\partial}{\partial t} + \alpha x \frac{\partial}{\partial x} - \alpha y \frac{\partial}{\partial y}$ ; thus

$$\frac{D\mathbf{u}}{Dt} = \frac{\partial \mathbf{u}}{\partial t} + \left( \alpha x \frac{\partial}{\partial x} - \alpha y \frac{\partial}{\partial y} \right) \mathbf{u} = \left( \alpha x \frac{\partial}{\partial x} - \alpha y \frac{\partial}{\partial y} \right) (\alpha x, -\alpha y) = (\alpha^2 x, \alpha^2 y).$$

---

The notion of acceleration can be explored further:

**Example 6**

*Velocity & Acceleration.* A particle starts ( $t = 0$ ) at the point  $(a, b, c)$ , and moves according to  $\mathbf{x} = (x, y, z) = \left( a(1+t)^2, b/(1+t), c/(1+t) \right)$ . Find the velocity and acceleration vectors directly; determine the velocity field in terms of  $x, y, z$  and  $t$  (by eliminating  $a, b$  and  $c$ ), and hence show that the acceleration is recovered from  $D\mathbf{u}/Dt$ .

---

We have  $\frac{d\mathbf{x}}{dt} = \left( 2a(1+t), -\frac{b}{(1+t)^2}, -\frac{c}{(1+t)^2} \right) = \mathbf{u}$ ;

correspondingly,

the acceleration is  $\frac{d^2\mathbf{x}}{dt^2} = \left( 2a, \frac{2b}{(1+t)^3}, \frac{2c}{(1+t)^3} \right)$ .

But we may write  $\mathbf{u} = \left( \frac{2x}{1+t}, -\frac{y}{1+t}, -\frac{z}{1+t} \right)$  for this velocity field i.e. for every point satisfying the given family of PPs; this flow field is therefore unsteady.

$$\begin{aligned}\text{Now } \frac{D\mathbf{u}}{Dt} &= \left( \frac{\partial}{\partial t} + \frac{2x}{1+t} \frac{\partial}{\partial x} - \frac{y}{1+t} \frac{\partial}{\partial y} - \frac{z}{1+t} \frac{\partial}{\partial z} \right) \mathbf{u} \\ &= \left( -\frac{2x}{(1+t)^2} + \frac{4x}{(1+t)^2}, \frac{y}{(1+t)^2} + \frac{y}{(1+t)^2}, \frac{z}{(1+t)^2} + \frac{z}{(1+t)^2} \right) = \left( 2a, \frac{2b}{(1+t)^3}, \frac{2c}{(1+t)^3} \right)\end{aligned}$$

exactly as before.

---

### 1.4 The equation of mass conservation

A fundamental equation (not usually expressed explicitly in elementary particle mechanics) is a statement of *mass conservation*. We can readily see the need for such an equation: the fluid is, in general, in motion and can produce a mixing of regions of different densities. Yet the total amount (mass) of material is presumably conserved; this total can change only if matter (material) is created or destroyed – and this will arise only if we allow e.g. the conversion of mass into energy! We now derive the equation which ensures that mass is indeed conserved.

Consider an imaginary (finite) volume  $V$ , bounded by a surface  $S$ , which is completely occupied by fluid; we shall take  $V$  (and  $S$ ) to be stationary in our chosen frame of reference (so that fluid will cross  $S$  into and out of  $V$ ). This figure shows the configuration schematically:

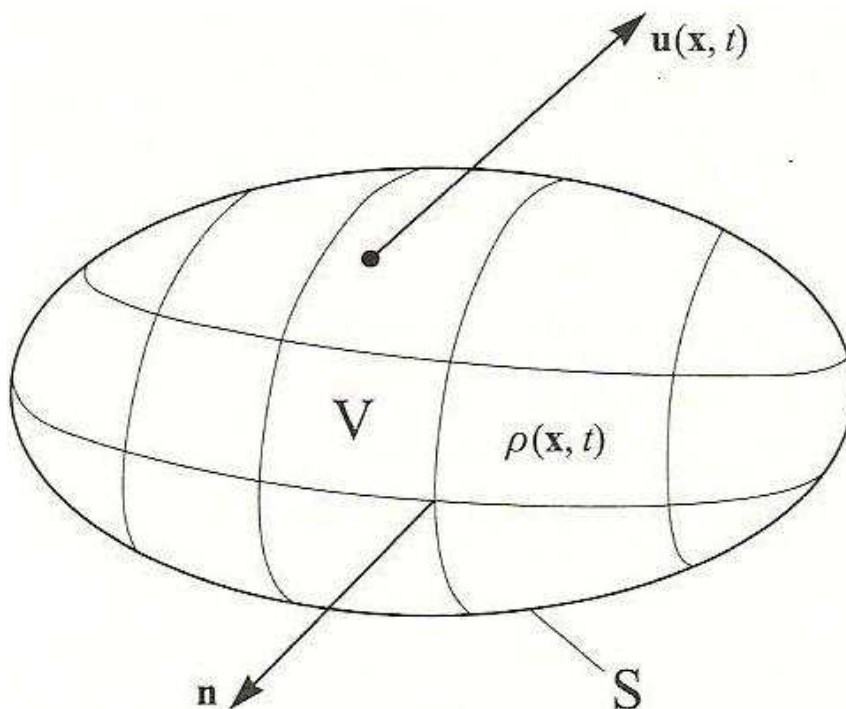

where  $\mathbf{n}$  is the outward unit normal on  $S$ , and  $\rho(\mathbf{x}, t)$  and  $\mathbf{u}(\mathbf{x}, t)$  are given at every point in  $V$  and on  $S$ . The total mass of all the fluid in  $V$ , at any instant in time, is then

$$\int_V \rho(\mathbf{x}, t) dv,$$

where  $\int_V (\cdot) dv$  denotes the triple integral in  $\mathbf{x}$  over  $V$ . The rate of change of this mass is therefore

$$\frac{d}{dt} \int_V \rho(\mathbf{x}, t) dv = \int_V \frac{\partial \rho}{\partial t} dv$$

because  $V$  is fixed in space. [See the property: ‘differentiation under the integral sign’, discussed in Exercise 10.]

Further, the net rate at which mass flows out of  $V$  across  $S$  is described in this figure:

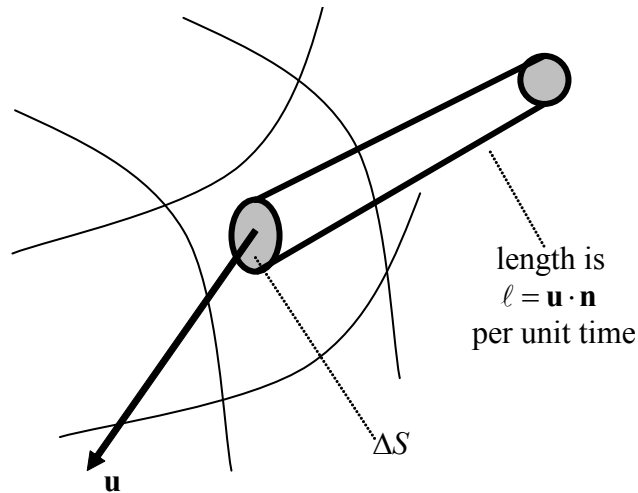

and so the volume of fluid (out) per unit time is approximately  $\ell \times \Delta S = \mathbf{u} \cdot \mathbf{n} \Delta S$ , producing a total mass flow rate (out), over all  $S$ , in the form

$$\int_S \rho \mathbf{u} \cdot \mathbf{n} \, ds,$$

where  $\int_S (\cdot) \, ds$  represents the double integral over  $S$ . We now impose the condition that the only mechanism that produces a change of mass in  $V$  is by virtue of material crossing  $S$  (into or out of  $V$ ), thereby excluding the possibility of matter (mass) being created or destroyed at any points in  $V$  or on  $S$ ; thus we require

$$\int_V \frac{\partial \rho}{\partial t} \, dv = - \int_S \rho \mathbf{u} \cdot \mathbf{n} \, ds.$$

The choice of sign here is to accommodate the obvious convention that  $\frac{\partial \rho}{\partial t} > 0$  requires material to enter  $V$  across  $S$ .

We now invoke the Divergence (Gauss') Theorem for the surface integral (where  $S$  bounds  $V$ ), to produce

$$\int_V \left( \frac{\partial \rho}{\partial t} + \nabla \cdot (\rho \mathbf{u}) \right) dv = 0.$$

However, this result must hold for all  $V$ s (and corresponding  $S$ s), irrespective of shape or size, which implies that the limits of the integral (denoted by  $V$ ) are arbitrary. But  $\frac{\partial \rho}{\partial t} + \nabla \cdot (\rho \mathbf{u})$  is assumed continuous, and so the requirement that the integral of this expression always be zero [see the fundamental idea discussed in Exercise 11] gives

$$\frac{\partial \rho}{\partial t} + \nabla \cdot (\rho \mathbf{u}) = 0$$

which is usually expressed [see the identities in Exercise 7] as

$$\frac{D\rho}{Dt} + \rho \nabla \cdot \mathbf{u} = 0,$$

the *equation of mass conservation* for a general fluid. Immediately we see that, if  $\rho = \text{constant}$  ( $> 0$ ), then we obtain

$$\nabla \cdot \mathbf{u} = 0$$

which is a statement that volume is conserved. Note that the equation of mass conservation requires both  $\rho$  and  $\mathbf{u}$  to be differentiable.

In rectangular Cartesian coordinates,  $\nabla \cdot \mathbf{u} = 0$  becomes  $\frac{\partial u}{\partial x} + \frac{\partial v}{\partial y} + \frac{\partial w}{\partial z} = 0$ ; in cylindrical polar coordinates  $(r, \theta, z)$ , with  $\mathbf{u} = (u, v, w)$ , this reads

$$\frac{1}{r} \frac{\partial(ru)}{\partial r} + \frac{1}{r} \frac{\partial v}{\partial \theta} + \frac{\partial w}{\partial z} = 0.$$

A check list of all the relevant equations, written in both rectangular Cartesian coordinates and cylindrical coordinates, is given in Appendix 2.

**Note:** The general definition of an incompressible fluid is that  $\rho = \text{constant}$  on each fluid particle (allowing different constants on different particles), so that  $\frac{D\rho}{Dt} = 0$ , leaving the same result as above:  $\nabla \cdot \mathbf{u} = 0$ . Our usual choice, appropriate for a conventional incompressible fluid, is a special solution of this system:  $\rho = \text{constant}$  everywhere. The equation  $\nabla \cdot \mathbf{u} = 0$  simply states that volume is conserved (which we could have derived directly, if we wished to limit our discussion to incompressible fluids).

**Comment:** We observe that, in the case where  $\frac{\partial \rho}{\partial t} + \nabla \cdot (\rho \mathbf{u})$  is not continuous, the integral representing mass conservation recovers a jump condition defining the relation between flow properties on either side of the discontinuity. In the context of a gas, this describes conditions across a shock wave in supersonic flow.

### **Example 7**

*Incompressible flow.* A flow is described by the velocity field  $\mathbf{u} \equiv (\alpha x, \beta y, \gamma z)$ ; what relation must exist between the constants  $\alpha, \beta, \gamma$  for this to represent an incompressible flow?

---

We have directly that  $\nabla \cdot \mathbf{u} = u_x + v_y + w_z = \alpha + \beta + \gamma$  (where subscripts have been used to denote partial derivatives); thus  $\alpha + \beta + \gamma = 0$  is the condition for this velocity field to represent an incompressible flow.

---

A more interesting example, leading to an important, simple result used in elementary calculations for flow along a pipe, is the following:

**Example 8**

*Pipe flow.* An incompressible flow, which is axisymmetric and non-swirling, moves along a circular pipe of varying cross-section (radius  $R(z)$ ). Find the relation between speed along the pipe and its cross-sectional area.

For incompressible flow in cylindrical coordinates, we have

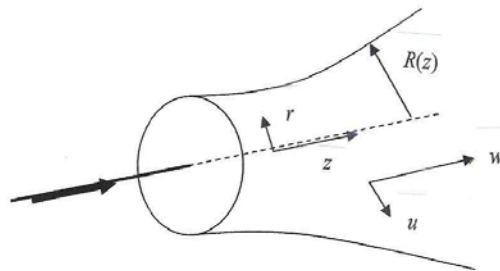

$\frac{1}{r} \frac{\partial}{\partial r}(ru) + \frac{1}{r} \frac{\partial v}{\partial \theta} + \frac{\partial w}{\partial z} = 0$ ; then for axisymmetry ( $\partial/\partial\theta \equiv 0$ ) and no swirl ( $v \equiv 0$ ), this reduces to  $\frac{1}{r} \frac{\partial}{\partial r}(ru) + \frac{\partial w}{\partial z} = 0$  (and note that either condition removes this term, but the first also ensures that no functions depend on  $\theta$ ). We write this equation as  $(ru)_r + (rw)_z = 0$

and then integrate across the pipe:

$$[ru]_0^{R(z)} + \int_0^{R(z)} (rw)_z dr = 0.$$

We now invoke the ‘differentiation under the integral sign’ (Exercise 10) to express this as

$$[ru]_0^{R(z)} + \frac{d}{dz} \left( \int_0^{R(z)} rw dr \right) - R w|_{r=R} R' = 0$$

but  $ru = 0$  on  $r = 0$ , so this becomes  $R(u - wR')|_{r=R} + \frac{d}{dz} \left( \int_0^{R(z)} rw dr \right) = 0.$

There are two cases of interest: first, for a viscous fluid, both  $u$  and  $w$  are zero at the inner surface of the pipe (because there can be no flow through the pipe, nor along the pipe), and so the evaluation on  $r = R(z)$  gives zero. On the other hand, we might suppose that the fluid can be modelled as inviscid (zero viscosity – no friction), in which case the fluid is allowed to flow along the inside surface of the pipe (but, as before, not through it). In this case, we must have that the velocity vector is parallel to the pipe wall i.e.  $(u/w)|_{r=R} = R'(z)$ , and again the evaluation on  $r = R(z)$  is zero.

$$\text{Thus } \frac{d}{dz} \left( \int_0^{R(z)} r w dr \right) = 0 \text{ and so } \int_0^{R(z)} r w dr = \text{constant, the required result.}$$

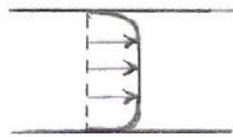

In the special case (e.g. a model) in which the velocity profile across the pipe is essentially independent of the radius ( $r$ ), the integral produces the rule: speed  $\times$  area = constant. This type of flow is usually referred to as *uniform across a section*, as depicted for a real flow which is nearly uniform across a section in the figure.

REDEFINE YOUR FUTURE  
**AXA GLOBAL  
GRADUATE PROGRAM**

redefining / standards 



### 1.5 Pressure and hydrostatic equilibrium

We now introduce the initial ideas that will, eventually, lead to an equation of motion – the corresponding Newton’s Second Law – for a fluid. The first stage is to discuss the forces that act on a fluid; there are three (although we shall put one of these aside, for the moment):

- force due to pressure (force/area), exerted by the fluid particles nearby
- internal friction (*viscous forces*) due to motion of other particles nearby
- external force (*body force*) that acts more-or-less equally on all fluid particles e.g. gravity.

The first two in this list are internal, local forces; in this discussion, we shall ignore any friction (and, in any event, there will be no motion, so friction cannot play any rôle). The pressure,  $p(\mathbf{x}, t)$ , is defined at every point in the fluid, and is independent of orientation (the fluid is said to be *isotropic*). Under the action of pressure and a body force – gravity, perhaps – the fluid is in *equilibrium*; we now construct the equation that describes this scenario.

As before, let us consider an imaginary volume  $V$ , surface  $S$ , with outward normal  $\mathbf{n}$  and totally occupied by fluid. Let the body force acting on the fluid be  $\mathbf{F}(\mathbf{x}, t)$  per unit mass; the pressure (due to the surrounding fluid) acts on  $S$ .

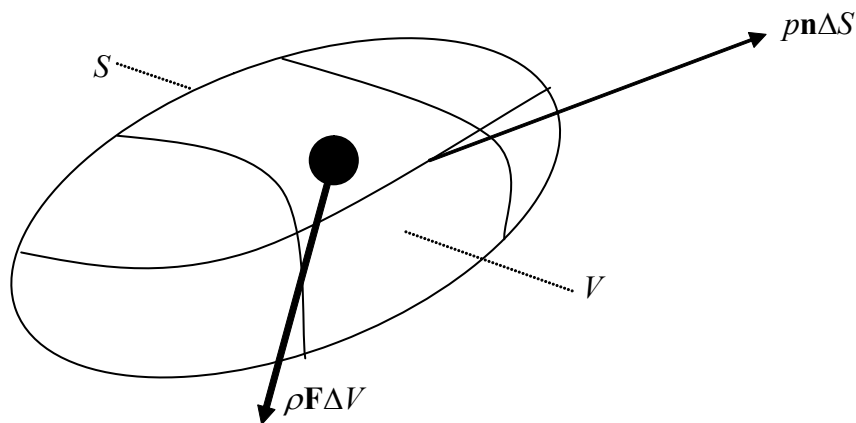

The total body force acting on all the fluid in  $V$  is thus

$$\int_V \rho \mathbf{F} dv;$$

correspondingly, the total pressure force acting on  $S$  is

$$-\int_S p \mathbf{n} ds.$$

There are no other forces acting, and there is no motion, so the resultant force on the fluid must be zero (the fluid is in equilibrium under the action of these forces) i.e.

$$\int_V \rho \mathbf{F} dv - \int_S p \mathbf{n} ds = \mathbf{0}.$$

(Note that the force, as expressed by the left-hand side, is force on.)

Again, we use the Divergence (Gauss') Theorem, to give (for the second term)

$$\int_S p \mathbf{n} ds = \int_V \nabla p dv \quad (\text{see Exercise 8}),$$

and so we obtain  $\int_V (\rho \mathbf{F} - \nabla p) dv = \mathbf{0}$ .

For this to be valid for all possible choices of  $V$  (and associated  $S$ ), and for a continuous integrand, we require

$$\rho \mathbf{F} - \nabla p = \mathbf{0} \quad \text{or} \quad \nabla p = \rho \mathbf{F};$$

this is the equation of hydrostatic equilibrium (because water is a special case!).

Note that the density here,  $\rho$ , is not necessarily a constant: we have made no assumptions about  $\rho$  or the nature of the fluid under discussion.

### **Example 9**

*Hydrostatic equilibrium.* Given that the body force is due to (constant) gravity, so that  $\mathbf{F} \equiv (0, 0, -g)$ , and that the pressure  $p = p_0$  on  $z = 0$ , find  $p(z)$  for an incompressible fluid (i.e.  $\rho = \text{constant}$ ) in hydrostatic equilibrium.

The governing equation is  $\nabla p = \rho \mathbf{F}$  i.e.  $\left( \frac{\partial p}{\partial x}, \frac{\partial p}{\partial y}, \frac{\partial p}{\partial z} \right) = \rho(0, 0, -g)$ , and so  $\frac{\partial p}{\partial x} = 0, \frac{\partial p}{\partial y} = 0$ , which gives  $p = p(z)$ . Then  $p'(z) = -\rho g$ , and so  $p = p_0 - \rho g z$ .

**Comment:** On the basis of the previous example, if  $z = 0$  is the surface of the ocean, then the pressure increases linearly with depth. On the other hand, if  $z = 0$  is the bottom of the atmosphere, then the pressure *decreases* linearly with height (but this is not a good model for the atmosphere – compressibility is important, with  $p = p(\rho)$ ).

In this model, also note that the rate of increase/decrease is very different for water/air, because of the very different densities; for example, the pressure drops to about half an atmosphere at a height of about  $5.5 \text{ km}$  in air, but it increases by one atmosphere at a depth of about  $10 \text{ m}$  in water.

## 1.6 Euler's equation of motion (1755)

We now take the representation of forces, as developed in §1.5, and let this be the resultant force acting on a fluid that is in motion. (Note that, using this system of forces, there is no internal friction – viscosity – which will be included later; in the absence of friction, we usually call this model fluid an *ideal* fluid.)

The application of Newton's Second Law, which is required to balance the force against the rate of change of momentum, can be done in a very simple-minded way; this is the option we choose in this presentation. A mathematically more complete derivation is given in Appendix 3.

Consider a (small) parcel of fluid, of volume  $\Delta V$ ; the force acting on this parcel, based on the details given for the case of equilibrium, is

$$(\rho \mathbf{F} - \nabla p) \Delta V \text{ approximately.}$$

This force, according to Newton's 2<sup>nd</sup> Law, produces an acceleration (see §1.3) in the form

$$\text{force} = \text{mass} \times \text{acceleration} = (\rho \Delta V) \frac{D\mathbf{u}}{Dt}.$$

**I'm with ZF.  
Engineer and Easy Rider.**

I enjoy motorcycle riding as a hobby. My mind is free and clear. I just feel great. Especially in this famous region where I live and work. Riding on the legendary Blue Ridge Parkway with its beautiful scenic views is breathtaking. I have a great life and a great job. The doors are always open and everybody helps each other out. My name is Charles Jenkins and I'm working as a quality engineer. For more about me, what I do, and why I really enjoy working at ZF, go to [www.im-with-zf.com](http://www.im-with-zf.com).

**Driveline and Chassis Technology** 

**Charles Jenkins**  
Quality Engineer  
ZF Friedrichshafen AG  
North Carolina/USA 

[www.im-with-zf.com](http://www.im-with-zf.com)



Thus we obtain the (approximate) equation

$$(\rho \Delta V) \frac{D\mathbf{u}}{Dt} = (\rho \mathbf{F} - \nabla p) \Delta V,$$

where  $\Delta V$  cancels; cancelling and – notionally – taking the limit to a point (i.e.  $\Delta V \rightarrow 0$ ), we obtain

$$\rho \frac{D\mathbf{u}}{Dt} = \rho \mathbf{F} - \nabla p \quad \text{or} \quad \frac{D\mathbf{u}}{Dt} = -\frac{1}{\rho} \nabla p + \mathbf{F}$$

which is *Euler's equation of motion* (1755). [L. Euler (1707-1783), Swiss mathematician, regarded as the 'father of fluids'.]

When the material derivative is written out, this equation becomes

$$\frac{\partial \mathbf{u}}{\partial t} + \mathbf{u} \cdot \nabla \mathbf{u} = -\frac{1}{\rho} \nabla p + \mathbf{F},$$

where, typically for us, we have  $\mathbf{F} = (0, 0, -g)$  (for constant acceleration of gravity). One component of this equation is

$$\frac{\partial u}{\partial t} + u \frac{\partial u}{\partial x} + v \frac{\partial u}{\partial y} + w \frac{\partial u}{\partial z} = -\frac{1}{\rho} \frac{\partial p}{\partial x} + F_1,$$

and correspondingly for the other two components.

**Comment:** We observe that we have 4 (scalar) equations (the three components of Euler and the equation of mass conservation) for the 5 unknowns:  $u, v, w, p, \rho$ . This system is closed by prescribing the nature of the fluid e.g.

$$\rho = \text{constant} \quad (\text{incompressibility}) \quad \text{or} \quad p = p(\rho) \quad (\text{for certain gases}).$$

In addition, we require appropriate boundary conditions (and also initial data for unsteady flows). Typically, we expect information about the velocity and/or pressure at the boundary of the fluid.

**Example 10**

*Euler's equation.* Show that the incompressible flow field  $\mathbf{u} \equiv (u(z), 0, 0)$  for any  $u(z)$ , where  $\mathbf{x} \equiv (x, y, z)$ , together with the hydrostatic pressure distribution, is an exact solution of Euler's equation with  $\mathbf{F} \equiv (0, 0, -g)$ .

We first check that  $\nabla \cdot \mathbf{u} = 0$ :  $\frac{\partial}{\partial x} u(z) + 0 + 0 = 0$  (correct);

then  $\frac{\partial \mathbf{u}}{\partial t} + \mathbf{u} \cdot \nabla \mathbf{u} = -\frac{1}{\rho} \nabla p + \mathbf{F}$  becomes

$$\left( \frac{\partial}{\partial t} + u \frac{\partial}{\partial x} + 0 \cdot \frac{\partial}{\partial y} + 0 \cdot \frac{\partial}{\partial z} \right) (u(z), 0, 0) = -\frac{1}{\rho} \left( \frac{\partial p}{\partial x}, \frac{\partial p}{\partial y}, \frac{\partial p}{\partial z} \right) + (0, 0, -g)$$

which is identically satisfied, with  $p = -\rho g z + \text{const.}$

Another, more physically interesting problem (now in cylindrical coordinates), is provided by the next example.



At Navigant, there is no limit to the impact you can have. As you envision your future and all the wonderful rewards your exceptional talents will bring, we offer this simple guiding principle: It's not what we do. It's how we do it.

**Impact matters.**

**NAVIGANT**  
navigant.com

DISPUTES & INVESTIGATIONS • ECONOMICS • FINANCIAL ADVISORY • MANAGEMENT CONSULTING

©2013 Navigant Consulting, Inc. All rights reserved. Navigant Consulting is not a certified public accounting firm and does not provide audit, attest, or public accounting services. See navigant.com/licensing for a complete listing of private investigator licenses.

**Example 11**

*Spinning fluid.* An incompressible fluid is rotating at constant angular speed,  $\omega$ , in a cylindrical vessel; it is otherwise in equilibrium under the action of (constant) gravity. Show that the surface (which is at constant atmospheric pressure) takes the form of a paraboloid.

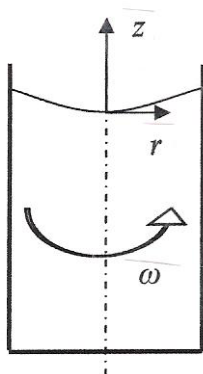

In cylindrical coordinates  $(r, \theta, z)$ , we have  $\mathbf{u} = (0, \omega r, 0)$  (see figure), and so Euler's equation reduces to

$$(0, 0, 0) + (-\omega^2 r, 0, 0) = -\frac{1}{\rho} \left( \frac{\partial p}{\partial r}, \frac{1}{r} \frac{\partial p}{\partial \theta}, \frac{\partial p}{\partial z} \right) + (0, 0, -g).$$

Thus

$$\frac{\partial p}{\partial \theta} = 0, \quad \frac{\partial p}{\partial r} = \rho \omega^2 r, \quad \frac{\partial p}{\partial z} = -\rho g$$

which has the solution  $p(r, z) = \frac{1}{2} \rho \omega^2 r^2 - \rho g z + \text{const.}$ ; but the surface is a surface of constant pressure – atmospheric pressure – and so the surface is described by the paraboloid:  $\frac{1}{2} \rho \omega^2 r^2 - \rho g z = \text{constant}$  (a parabola in  $(r, z)$  coordinates).

An important final observation, before we move on – and which is explored in Exercise 35 – is the following. The governing equations are the same, whether an object is moving at constant speed through a fluid, or the fluid flows at this same constant speed past a fixed object. This implies that the situation in the laboratory – flow past an object in a wind tunnel, for example – can correspond precisely with the same object flying through the air. This property of the equations is called *Galilean invariance*.

## Exercises 1

1. *Algebra (relevant to gases)*. Given that  $p = \rho RT$  and that  $p = k\rho^\gamma$  (where  $R$ ,  $k$  and  $\gamma$  are positive constants with  $1 < \gamma < 2$ ), find: (a)  $T$  in terms of  $\rho$ ; (b)  $T$  in terms of  $p$ . [Here,  $p$  is pressure,  $T$  is temperature and  $\rho$  is density.]
2. *More algebra (for gases)*. Repeat Ex.1 (a), (b), for the more accurate model

$$(p + a\rho^2)(1 - b\rho) = \rho RT \quad ; \quad p = k\rho^\gamma,$$

where  $a$  and  $b$  are also positive constants. [This model incorporates the improvement for a gas first introduced by van der Waals.]

3. *Approximation*. Use the relation between  $p$ ,  $\rho$  and  $T$  given in Ex.2, taking  $a$  and  $b$  to be *small* constants, to find an approximate expression for  $p$  in terms of  $T$  and  $\rho$ , which is correct as far as terms in  $\rho^2$ .
4. *Special case (relevant to our fluids)*. See Ex.1; given that  $p = k\rho^\gamma$ ,  $p = \rho RT$  and that  $T = \text{constant}$ , show that  $\gamma = 1$ . What now is the constant  $k$ ? [This is the situation that we shall often encounter in our discussions because we shall not entertain the possibility of changes in temperature; such an approach would require a consideration of thermal energy and thermodynamics.]
5. *Differential equations I*. Solve the differential equation  $dy/dx = v/u$ , given  $u$  and  $v$  as follows, where  $a$  and  $t$  are constants :

$$\text{(a) } u=ax, \quad v=2ay; \quad \text{(b) } u=-4ay, \quad v=ax; \quad \text{(c) } u=xt, \quad v=-yt; \quad \text{(d) } u=xt, \quad v=-y.$$

Now use suitable software (e.g. MAPLE) to plot

- (e) for problem (a), the three curves which pass through (1,1), (1,2) and (1,3), respectively, for  $0 \leq x \leq 3$ , all on one graph;
- (f) for problem (d), the three curves which pass through (1,1), (2,1) and (3,1), respectively, for  $0.5 \leq x \leq 5$ , all on one graph, for each of  $t = 0, 1, 2$ .

6. *Differential equations II*. Solve the pair of differential equations  $dx/dt = u$ ,  $dy/dt = v$ , where  $t$  is now a variable, for  $u$  and  $v$  as given in Ex.5, with the conditions

$$\text{(a) \& (c) } x = x_0, \quad y = y_0 \quad \text{at } t = 0; \quad \text{(b) } x = y = 1 \quad \text{at } t = 0; \quad \text{(d) } x = x_0, \quad y = y_0 \quad \text{at } t = 1.$$

Now use suitable software (e.g. MAPLE) to plot

(e) for problem (a), the three paths  $(x(t), y(t))$ , with  $a = 1, x_0 = 1, y_0 = 1, 2, 3$ , respectively, for  $0 \leq t \leq 1$  all on the same graph;

(f) for problem (d), the three paths  $(x(t), y(t))$ , with  $y_0 = 1, x_0 = 1, 2, 3$ , respectively, for  $0 \leq t \leq 2$ , all on the same graph.

7. *Some differential identities.* Given that  $\phi(\mathbf{x})$  is a general scalar function, and that  $\mathbf{u}(\mathbf{x})$  and  $\mathbf{v}(\mathbf{x})$  are general vector-valued functions, use any appropriate method to show that

$$(a) \nabla \cdot (\phi \mathbf{u}) = (\mathbf{u} \cdot \nabla) \phi + \phi (\nabla \cdot \mathbf{u});$$

$$(b) \nabla \wedge (\phi \mathbf{u}) = (\nabla \phi) \wedge \mathbf{u} + \phi (\nabla \wedge \mathbf{u});$$

$$(c) \mathbf{u} \wedge (\nabla \wedge \mathbf{u}) = \nabla(\mathbf{u} \cdot \mathbf{u} / 2) - (\mathbf{u} \cdot \nabla) \mathbf{u};$$

$$(d) \nabla \wedge (\mathbf{u} \wedge \mathbf{v}) = \mathbf{u}(\nabla \cdot \mathbf{v}) - (\mathbf{u} \cdot \nabla) \mathbf{v} + (\mathbf{v} \cdot \nabla) \mathbf{u} - \mathbf{v}(\nabla \cdot \mathbf{u}),$$

and in (c) you are advised to consider one component only (if subscript notation is not adopted), since the others follow cyclically, and work from the r.h.s to recover the l.h.s.; here, we have used  $\wedge$  as an alternative to  $\times$  (for the cross product).

8. *Two integral identities.* A volume  $V$  is bounded by the surface  $S$  on which there is defined the outward normal unit vector,  $\mathbf{n}$ . Given that  $\phi(\mathbf{x})$  is a general scalar function, use Gauss' theorem (the 'divergence theorem') to show that



Success here is about overcoming challenges – especially the ones we didn't even think of. I look forward to that.

- Scott, Mechanical Engineering Group Leader

**Collaborating. Inspiring. Leading.**

Monsanto has always embraced innovation and always focused on helping to make a better world. You can see it in our groundbreaking products and in our dynamic environment where your skills and your career can grow and develop. We know that every day, new ideas can come from anyone, anywhere. At Monsanto, you'll be respected, you'll contribute to the bottom line and you'll help farmers feed the world.

**Start right now: [www.monsanto.com/students](http://www.monsanto.com/students)**

**MONSANTO** 

ER00/AA EMPLOYER M07/EN/04 ©2013 Monsanto Company



$$\int_V \nabla \phi \, dv = \int_S \phi \mathbf{n} \, ds,$$

and, for the vector function  $\mathbf{u}$ , that

$$\int_V \nabla \wedge \mathbf{u} \, dv = \int_S \mathbf{n} \wedge \mathbf{u} \, ds.$$

[In the first, take the vector in Gauss' theorem to be  $\phi \mathbf{k}$ , and in the second take the vector to be  $\mathbf{k} \wedge \mathbf{u}$ ;  $\mathbf{k}$  is an arbitrary constant vector in each case.]

9. *Another integral identity.* A surface  $S$  is bounded by the closed curve  $C$ . Use Stokes' theorem to show that

$$\int_C \phi \, d\mathbf{l} = \int_S (\mathbf{n} \wedge \nabla \phi) \, ds,$$

where  $\phi$  is an arbitrary function. [Use the same idea as in Ex.8.]

10. *Differentiation under the integral sign.* Given

$$I(x) = \int_{a(x)}^{b(x)} f(x, y) \, dy,$$

show that

$$\frac{dI}{dx} = \int_{a(x)}^{b(x)} \frac{\partial}{\partial x} f(x, y) \, dy + f(x, b) \frac{db}{dx} - f(x, a) \frac{da}{dx},$$

provided the integral of  $\partial f / \partial x$ , and the functions  $da/dx$  and  $db/dx$ , exist.

[It is helpful to introduce the *primitive* of  $f(x, y)$  at fixed  $x$ : that is  $g(x, y) = \int f(x, y) \, dy$ .]

(a) Verify that this formula recovers a familiar and elementary result in the case :

$$f = f(y), b(x) = x, a(x) = \text{constant}.$$

(b) Use this result to find  $\frac{d}{dx} \left( \int_{2x}^{3x} \sin \left[ (x+y)^2 \right] dy \right)$ .

(c) Use this result to simplify  $\frac{d}{dz} \left( \int_0^{R(z)} r w(r, z) dr \right)$ , and then simplify further given that  $w_z = r^2 \exp(-z^2)$ .

11. Show that, if

$$\int_a^b f(x) dx = 0,$$

for arbitrary (i.e. all) values of  $a$  and  $b$ , then  $f(x) \equiv 0$ .

[Hint: you may write  $f(x) = g'(x)$ , although other, more general methods of proof are possible.]

**12. Streamlines and particle paths.** In the following problems, the velocity components of a flow (represented in rectangular Cartesian coordinates  $\mathbf{x} \equiv (x, y, z)$ ,  $\mathbf{u} \equiv (u, v, w)$  and  $t$  time) are given; find the streamlines in each case, and the particle path which passes through  $\mathbf{x} \equiv (x_0, y_0, z_0)$  at  $t = 0$ . (Here,  $k, c$  and  $\omega$  are constants.)

(a)  $u = kx, v = -ky, w = 0$ ; (b)  $u = 2xt, v = -2yt, w = 0$ ;

(c)  $u = x - t, v = -y, w = 0$ ; (d)  $u = xt, v = -y, w = 0$ ;

(e)  $u = 2x/t, v = -y/t, w = 0$ ; (f)  $u = xy^2/t, v = t/y, w = 0$ ;

(g)  $u = ky, v = -kx + kct, w = 0$ ; (h)  $u = kx^2, v = ky^2, w = -2k(x + y)z$ ;

(i)  $u = 0, v = -z + \cos(\omega t), w = y + \sin(\omega t)$  for  $\omega \neq \pm 1$ ;

(j) see (i) with  $\omega = 0$ .

**13. Steady flows I.**

(a) Determine which of the flows discussed in Ex.12 are steady.

Now use suitable software (e.g. MAPLE) to plot

(b) for problem Ex.12(a): the three streamlines which pass through (1,1), (1,2) and (1,3), respectively, for  $0.5 \leq x \leq 5$ , all on the same graph;

(c) see (b); the three particle paths, for  $k = 1$ , which pass through (1,1), (2,1) and (3,1), respectively, at  $t = 0$ , for  $0 \leq t \leq 1$  (all on the same graph);

(d) for problem Ex.12(c): the three streamlines, at  $t = 1$ , which pass through (2,1), (2,2) and (2,3), respectively, for  $1.5 \leq x \leq 10$ , all on the same graph;

(e) see (d); the three particle paths which pass through (2,1), (3,1) and (4,1), respectively, at  $t = 0$ , for  $0 \leq t \leq 1$ , all on the same graph.

**14. Steady flows II.** A particle (point) in a fluid flow moves according to the rule  $\mathbf{x} \equiv (x_0 e^{\alpha t}, y_0 e^{\beta t}, z_0 e^{\gamma t})$ , where  $x_0, y_0, z_0, \alpha, \beta, \gamma$  are constants,  $\mathbf{x}$  is the position vector and  $t$  is time. Find an expression for the velocity vector  $\mathbf{u}$ .

Is this a steady flow? Find the streamlines for this flow.

- 15. *SLs and PPs I.* The velocity components of a flow are  $(2t^\alpha x^{-2}, 3t^{3\alpha} y^{-1})$ , where  $\alpha > -1/3$  is a constant. Find the streamlines for this flow and the particle path which passes through  $(1, 1)$  at  $t = 0$ . State (without performing a calculation) the value of  $\alpha$  for which the families of streamlines and particle paths coincide.
- 16. *SLs and PPs II.* See Ex. 15; repeat this for  $(x^2 e^{\alpha t}, y^{-1} e^{2\alpha t})$ .
- 17. *SLs and PPs III.* See Ex. 15; repeat this for  $(\alpha t - x, y^2 t^\alpha)$  with  $\alpha \neq -1$ , where the particle path passes through  $(0, 1)$  at  $t = 0$ .
- 18. *Acceleration of a fluid particle.* The velocity vector which describes the motion of a particle (point) in a fluid is  $\mathbf{u} = \mathbf{u}(\mathbf{x}, t)$ , so that the particle follows a path defined by

$$\frac{d\mathbf{x}}{dt} = \mathbf{U}(t) = \mathbf{u}(\mathbf{x}(t), t).$$

Introduce rectangular Cartesian coordinates and hence show that the acceleration of the particle  $\left(\frac{d\mathbf{U}}{dt}\right)$  is  $\frac{\partial \mathbf{u}}{\partial t} + (\mathbf{u} \cdot \nabla) \mathbf{u} = \frac{D\mathbf{u}}{Dt}$ , the material derivative.

- 19. *Material derivative I. (a)* A fluid moves so that its velocity vector, written in rectangular Cartesian coordinates, is  $\mathbf{u} \equiv (2xt, -yt, -zt)$ , where  $t$  is time. Show that the following property (function) is constant on – moving with – fluid particles :



Are you  
the surfer  
or the  
wave?

Creating the future of communications technology requires to be a powerful force for change and at the same time be swift and agile enough to deliver even in varying conditions. Which is why when you look at our history of innovation you'll find countless awards and even a handful of Nobel Prizes in our company résumé. And when you look at our teams, you will find dynamic, diverse, passionate professionals. Hand-in-hand, team by team, every day we bring innovations to market to help realize the potential of a connected world.

..... Alcatel·Lucent  
www.alcatel-lucent.com/careers

Alcatel·Lucent 



$$f(x, y, z, t) = x^2 \exp(-2t^2) + (y^2 + 2z^2) \exp(t^2).$$

What is the constant value of  $f$  on a particle? (This will involve arbitrary constants that arise in the integration process.)

(b) Repeat (a) for  $\mathbf{u} \equiv (-x/t, -y/(2t), 3z/(2t))$ ,  $f = x^2 t^2 + y^2 t - z^2 / t^3$ .

20. *Material derivative II.* Find a velocity field,  $\mathbf{u} \equiv (u, v, w)$ , for which the property  $f = x^2 / (a^2 t^4) + kt^2 (y^2 / b^2 + z^2 / c^2)$ , where  $a, b, c$  and  $k$  are constants, is constant on fluid particles.

21. *Eulerian vs. Lagrangian description.* The *Eulerian* description of the motion of a fluid is represented by  $\mathbf{u}(\mathbf{x}, t)$ , that is, the velocity at any point and at any time. The *Lagrangian* description follows a *given* particle (point) in the fluid; the Lagrangian velocity is  $\mathbf{u}(\mathbf{x}_0, t)$ , where  $\mathbf{x} = \mathbf{x}_0$  labels the particle at  $t = 0$ .

A particle moves according to the rule

$$\mathbf{x} \equiv (x, y, z) = (x_0 \exp(2t^2), y_0 \exp(-t^2), z_0 \exp(-t^2)),$$

written in rectangular Cartesian coordinates, where the particle is at  $\mathbf{x} = \mathbf{x}_0 \equiv (x_0, y_0, z_0)$  at time  $t = 0$ .

(a) Find the velocity of the particle in terms of  $\mathbf{x}_0$  and  $t$  – the *Lagrangian* description – and then show that the velocity field can be written as  $\mathbf{u} \equiv (4xt, -2yt, -2zt)$ , which is the *Eulerian* description.

(b) Now obtain the acceleration of the particle from the *Lagrangian* description.

(c) Show that the *Lagrangian* acceleration (that is, following a particle) is recovered from  $\frac{D\mathbf{u}}{Dt} = \frac{\partial \mathbf{u}}{\partial t} + (\mathbf{u} \cdot \nabla)\mathbf{u}$

22. *Velocity and acceleration.* A particle starts from  $\mathbf{x} \equiv (a, b)$  at  $t = 0$ , and moves according to  $x \equiv (x, y) = (a(1+t)^2, b/(1+t)^2)$ . Find the velocity and acceleration directly, and then find an expression for the velocity field (by eliminating  $a$  and  $b$ ) and hence show that the acceleration is recovered from  $D\mathbf{u}/Dt$ .

23. *Incompressible flow I.* (a) Determine which velocity fields given in Ex.12 represent incompressible flows.

(b) Repeat (a) for Ex.19, Ex.20 and Ex.21.

(c) What relation must exist between  $\alpha, \beta, \gamma$  so that the velocity field given in Ex.14 represents an incompressible flow?

24. *Incompressible flow II.* (a) A velocity field is

$$\mathbf{u} = f(r)\mathbf{x} \text{ where } r = |\mathbf{x}| = \sqrt{x^2 + y^2 + z^2}$$

and  $f$  is a scalar function. Find the most general form of  $f(r)$  so that  $\mathbf{u}$  represents an incompressible flow.

(b) With the same notation as in (a), find the conditions necessary on the constants  $a, b$  and  $c$  which ensure that  $\mathbf{u} \equiv (ax^2 - r^2, bxy, cxz)/r^5$  represents an incompressible flow.

(c) Repeat (b) for the velocity field  $\mathbf{u} \equiv (x + ar, y + br, z + cr)/\{r(x + r)\}$ .

25. *Incompressible flow III.* A flow is represented by the velocity field

$$\mathbf{u} \equiv \left( -\frac{2xyz}{d^2}, \frac{(x^2 - y^2)z}{d^2}, \frac{y}{d} \right) \text{ where } d = x^2 + y^2.$$

Show that this describes an incompressible flow.

26. *Incompressibility IV.* A velocity field is given by  $\mathbf{u} \equiv (f, y^2zt, z^2yt)$  where  $t$  is time; find  $f(x, y, z, t)$  for which this flow is incompressible and which satisfies  $f = 0$  on  $x = 0$  for all  $y, z, t$ .

27. *Mass conservation.* Show that

$$\mathbf{u} \equiv (\alpha xt, -yt, -zt) \text{ and } \rho = x^2 \exp(-\alpha t^2) + (y^2 + 2z^2) \exp(t^2)$$

satisfy the equation of mass conservation for one value of the constant  $\alpha$ ; what is this value?

28. *Beltrami flow.* A Beltrami flow is one for which the vorticity and velocity vectors are everywhere parallel. Write  $\boldsymbol{\omega} = k\mathbf{u}$  (where  $k$  is a non-zero constant) and seek a velocity field that is consistent with this equation and of the form

$$\mathbf{u} \equiv (u(x, y, z), v(x, y, z), w(x)),$$

but it is not necessary to find a general solution – just find any (non-zero) solution.

29. *Pipe flow.* A pipe with a rectangular cross-section,  $-a(x) \leq y \leq a(x)$ ,  $-b(x) \leq z \leq b(x)$ , with its centre-line along the  $x$ -axis, has a non-swirling, incompressible flow through it. Show that

$$\int_{-b-a}^b \int_{-a}^a u \, dx \, dy = \text{constant},$$

and hence recover the standard result (see §1.4, Example 8) for a flow which is uniform across every section.

30. *Branching pipe.* A pipe, of cross-sectional area  $A$ , branches into two, one of area  $nA$  and the other of area  $mA$ . The speed of an incompressible fluid at area  $A$  is  $u$  and at area  $nA$  it is  $v$ ; find the speed in the branch of area  $mA$ . (Assume

that the flow is uniform at all sections away from the junction, and that the fluid completely fills both the feed pipe and the two branch pipes, without leaks or other branches i.e. mass is conserved.)

31. *Hydrostatic equilibrium I.* A fluid in (vertical) hydrostatic equilibrium satisfies

$$\frac{dp}{dz} = -\rho g \quad (g \text{ constant}) ; \text{ see Lecture Notes.}$$

(a) Given that  $p = k\rho^\gamma$ , where  $k$  and  $\gamma$  are positive constants, and that  $p = p_0$ ,  $\rho = \rho_0$  on  $z = 0$ , find  $\rho(z)$  and  $p(z)$  for  $1 < \gamma < 2$ . Given, further, that  $p = \rho RT$  ( $R$  constant), find  $T(z)$  – the temperature – and deduce that  $dT/dz = \text{constant}$ .

(b) Repeat (a) for  $\gamma = 1$ .

(c) An ocean, in  $z \leq 0$ , is modelled by the density variation  $\rho = \rho_0(1 - \alpha z)$ , where  $\alpha$  (presumably small!) and  $\rho_0$  are positive constants. Find  $p(z)$ , given that  $p = p_0$  on  $z = 0$ .

(d) Repeat (c) for  $\rho = \rho_0(1 + \alpha\sqrt{-z})$ .

## Budget-Friendly. Knowledge-Rich.

The Agilent InfiniiVision X-Series and 1000 Series offer affordable oscilloscopes for your labs. Plus resources such as lab guides, experiments, and more, to help enrich your curriculum and make your job easier.



Scan for free Agilent iPhone Apps or visit [qrs.ly/po20pli](http://qrs.ly/po20pli)



Oscilloscope Education Training Kit  
For the InfiniiVision X-Series oscilloscopes  
Agilent Technologies



DSOXEDK Educator's Oscilloscope Training Kit  
Lab Guide and Manual for Undergraduate Electrical Engineering and Physics Students  
Agilent Technologies

**See what Agilent can do for you.**  
[www.agilent.com/find/EducationKit](http://www.agilent.com/find/EducationKit)

© Agilent Technologies, Inc. 2012 u.s. 1-800-829-4444    canada: 1-877-894-4414

Anticipate — Accelerate — Achieve



Agilent Technologies



(e) The atmosphere is modelled as a perfect gas, so  $p = \rho RT$  ( $R$  constant), with the temperature gradient prescribed according to

$$\frac{dT}{dz} = \begin{cases} -\alpha g/R, & 0 \leq z \leq H \\ 0, & z > H, \end{cases}$$

where  $\alpha$  is a positive constant. Given that  $T = T_0$  (with  $\alpha gH / RT_0 < 1$ ) and  $p = p_0$  on  $z = 0$ , find  $T(z)$  and  $p(z)$  where both these functions are continuous on  $z = H$ . What is the behaviour of your solution for  $z \rightarrow \infty$ ?

[Comment: Typically, the temperature in the Earth's atmosphere drops linearly by about  $70^\circ\text{C}$  in the first 11 km (the *troposphere*), and then remains roughly constant (in the *stratosphere*) up to about 35 km.]

(f) See (a); find  $\rho(z)$  (only) given that  $g$  is replaced by  $g_0 / (1 + \alpha z)^2$  ( $g_0$  and  $\alpha$  positive constants). What is the significance of this choice for  $g$ ?

32. *Hydrostatic equilibrium II.* A fluid is at rest, in hydrostatic equilibrium; the fluid is described  $p = k\rho$ , where  $k$  is a constant, with  $p = p_0$  and  $\rho = \rho_0$  on  $z = 0$ . Determine  $k$  and then find  $p(z)$ , given that the body force is that associated with constant gravity ( $\mathbf{F} \equiv (0, 0, -g)$ ).

33. *Archimedes' Principle.* A surface  $S$  encloses fluid of volume  $V$  which contains a solid body of volume  $V_b$  (surface  $S_b$ ). The fluid exerts a resultant pressure force,  $\mathbf{R}$ , on  $V_b$ , given by  $\int_S p \mathbf{n} ds$ . Show that, in hydrostatic equilibrium,

$$\mathbf{R} = \int_{S_b} p \mathbf{n} ds = \int_V \rho \mathbf{F} dv - \int_S p \mathbf{n} ds$$

and hence deduce that  $\mathbf{R} = - \int_{V_b} \rho \mathbf{F} dv$  (which is Archimedes' Principle, if  $\mathbf{F} = \mathbf{g}$ ).

34. *Euler's equation.* An incompressible ( $\rho = \text{constant}$ ) flow in two dimensions [ $\mathbf{x} \equiv (x, z)$ ], with  $\mathbf{F} \equiv (0, -g)$ , satisfies Euler's equation. For this flow, the velocity is  $\mathbf{u} \equiv (u_0, w(x))$ , where  $u_0$  is a constant, with  $w = 0$  on  $x = 0$  and  $p = p_0$  on  $z = 0$ . Find the solution for  $w$  and  $p$ , and show that it contains one free parameter.

35. *Galilean invariance.* Consider an incompressible flow which comprises, in part, a uniform flow  $\mathbf{u} = \mathbf{u}_0 = \text{constant}$ . Write  $\mathbf{u} = \mathbf{u}_0 + \mathbf{U}$  and hence find the appropriate forms taken by the mass conservation and Euler equations, written in terms of  $\mathbf{u}_0$  and  $\mathbf{U}$ . Now introduce a frame of reference that is moving at the constant velocity  $\mathbf{u}_0$ , by setting

$$\mathbf{U} = \hat{\mathbf{U}}(\hat{\mathbf{x}}, t), \quad p = \hat{p}(\hat{\mathbf{x}}, t) \quad \text{where} \quad \hat{\mathbf{x}} = \mathbf{x} - \mathbf{u}_0 t \quad (\equiv (x - u_0 t, y - v_0 t, z - w_0 t)).$$

Show that the equations written in terms of  $\hat{\mathbf{U}}$ ,  $\hat{p}$  and  $\hat{\mathbf{x}}$  are identical to the original equations of motion.

[This important property is known as 'Galilean invariance'; it means, for example, that the constant velocity of an object moving through a stationary fluid is identical to the constant velocity of the fluid past a stationary object.]

\*\*\*\*\*  
\*\*\*\*\*

# 2 Equations: Properties and Solutions

We now investigate the governing equations (Euler and mass conservation) in a little more detail. We shall describe some general (and important) properties of flows that will be useful in our later work, and that are relevant in certain types of studies of fluid motions. We also show how two integrals of the equation of motion can be derived – valid under slightly different modelling assumptions – which are quite significant in the application of these ideas to practical problems.

## 2.1 The vorticity vector and irrotational flow

A concept that permeates much of fluid theory is the notion of *vorticity*. It is an important property of a fluid flow, both in terms of what is observed in real flows and the rôle it plays in allowing theoretical headway. As we shall see, this provides a measure of the local spin or rotation exhibited by fluid elements. It is defined by

$$\boldsymbol{\omega} = \nabla \wedge \mathbf{u} \quad (\text{i.e. } \boldsymbol{\omega} = \text{curl } \mathbf{u} \text{ or } \boldsymbol{\omega} = \nabla \times \mathbf{u})$$

and one simple observation follows directly. If the flow is restricted to motion and variation in only 2D –  $(x, y)$  say – then we see that

$$\boldsymbol{\omega} = \left( \frac{\partial}{\partial x}, \frac{\partial}{\partial y}, \frac{\partial}{\partial z} \right) \wedge (u(x, y, t), v(x, y, t), 0) = (0, 0, v_x - u_y):$$

the vorticity possesses a component in only the third ( $z$ -) direction! (Note that this is valid for unsteady flows – time dependence is permitted, although much of our work will be for steady flows.)

Vorticity has a simple interpretation, which we will show by examining a flow which is purely 2D; the idea is readily extended to 3D (but is then more difficult to represent diagrammatically). Consider the flow in the  $(\Delta x, \Delta y)$  neighbourhood of a general point  $(x, y)$ , described by some general velocity field:

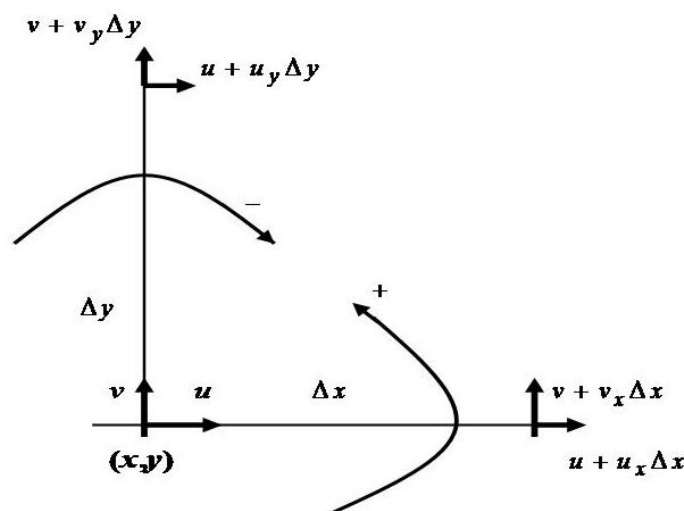

Here, we have approximated the velocity components near to  $(x, y)$  by invoking the simplest approximation provided by Taylor expansions; we assume, of course, that the velocity field allows this approach. The average angular speed, relative to the origin (labelled  $(x, y)$  here, for any point in the 2D plane) is approximately

$$\frac{1}{2} \left( \frac{v_x \Delta x}{\Delta x} - \frac{u_y \Delta y}{\Delta y} \right) = \frac{1}{2} (v_x - u_y),$$

on noting the sign convention that we have adopted for rotations about the origin. This is one half of the  $z$ -component of the vorticity vector  $\boldsymbol{\omega} = \nabla \wedge \mathbf{u}$  (as given above). We see, therefore, that vorticity measures the local rotation (or spin) of fluid elements. We comment that this should not be confused with solid-body rotation (and simple interpretations are often misleading!) exhibited by a solid object in rotation. The next example may help to clarify what is, and what is not, a flow with vorticity.

# The financial industry needs a strong software platform

That's why we need you

Working at SimCorp means making a difference. At SimCorp, you help create the tools that shape the global financial industry of tomorrow. SimCorp provides integrated software solutions that can turn investment management companies into winners. With SimCorp, you make the most of your ambitions, realising your full potential in a challenging, empowering and stimulating work environment.

Are you among the best qualified in finance, economics, computer science or mathematics?

**Find your next challenge at [www.simcorp.com/careers](http://www.simcorp.com/careers)**



“When I joined SimCorp, I was very impressed with the introduction programme offered to me.”

Meet Lars and other employees at [simcorp.com/meetouremployees](http://simcorp.com/meetouremployees)

Mitigate risk | Reduce cost | Enable growth  
[simcorp.com](http://simcorp.com)





**Example 12**

*Vorticity.* (a) Sketch the flow field  $\mathbf{u} \equiv (\alpha y, 0, 0)$ , where  $\alpha > 0$  is a constant, and find its vorticity. (b) Describe the flow field

$$\mathbf{u} = \left( -y/(x^2 + y^2), x/(x^2 + y^2), 0 \right).$$

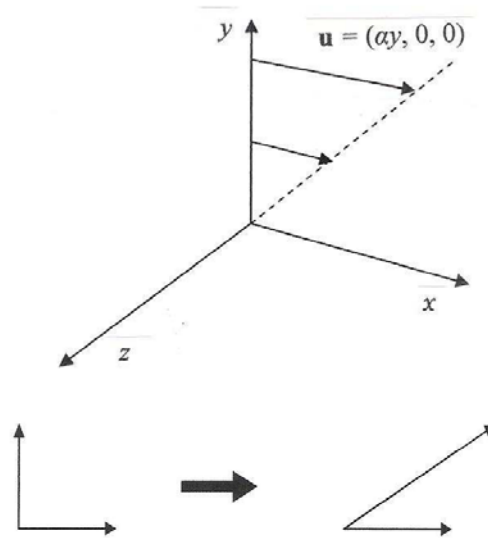

(a) We have  $u = \alpha y$ ,  $v = w = 0$ , and so the velocity field appears as shown in the figure (drawn for  $\alpha > 0$  and only in the positive  $y$ -direction – for ease of interpretation). There is no apparent (local) spin, yet the vorticity is  $\boldsymbol{\omega} = (0, 0, v_x - u_y) = (0, 0, -\alpha)$ , which represents constant (negative) vorticity around the  $z$ -axis. That this is reasonable becomes evident when we consider points for larger  $y$  as compared with those for smaller: such points move in the positive  $x$ -direction further than those lower down, resulting in a relative rotation; see figure.

(b) In this case,

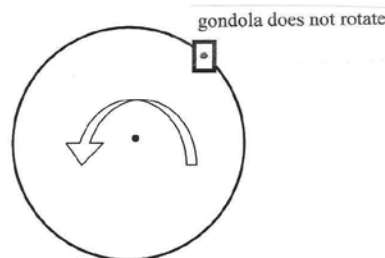

$$v_x - u_y = \frac{1}{x^2 + y^2} - \frac{2x^2}{(x^2 + y^2)^2} - \left[ -\frac{1}{x^2 + y^2} + \frac{2y^2}{(x^2 + y^2)^2} \right] = 0,$$

so the vorticity is zero (but note that it is not defined at the origin). Further, it is easy to check – for example, construct  $x\dot{y} - y\dot{x}$  – that the flow is circular i.e. the PP's are circles. How can this be? A good analogy is the motion of a gondola on a Ferris wheel: the wheel rotates, but each individual gondola does not.

---

**Comment:** Almost all real flows possess non-zero vorticity, but many have almost zero vorticity almost everywhere. Indeed, a good model, for many flows, is obtained by assuming that  $\boldsymbol{\omega} \equiv \mathbf{0}$  (or  $\boldsymbol{\omega} = \mathbf{0}$  except at isolated points or regions).

Regions of a flow field where  $\boldsymbol{\omega} = \mathbf{0}$  are called *irrotational* (for obvious reasons). When this condition holds, we have  $\mathbf{0} = \boldsymbol{\omega} = \nabla \wedge \mathbf{u}$ , which implies that there exists an arbitrary scalar function,  $\phi(\mathbf{x}, t)$  such that  $\mathbf{u} = \nabla \phi$ ; this is called the *velocity potential*. (The existence of  $\phi$  follows from Stokes' Theorem; see Exercise 39.) Once we know  $\phi(\mathbf{x}, t)$ , we can obtain  $\mathbf{u}$  directly.

**Example 13**

*Velocity potential.* Show that  $\mathbf{u} \equiv (2xyz, x^2z, x^2y)$  represents an irrotational flow, and find its velocity potential.

---

To be irrotational, we require  $\boldsymbol{\omega} = \nabla \wedge \mathbf{u} = \mathbf{0}$ , which here gives

$$\boldsymbol{\omega} = (x^2 - x^2, 2xy - 2xy, 2xz - 2xz) = \mathbf{0}, \text{ so irrotational.}$$

Now we have  $u = \phi_x = 2xyz, v = \phi_y = x^2z, w = \phi_z = x^2y$ , which give, respectively,

$$\phi = x^2yz + F(y, z), \phi = x^2yz + G(x, z), \phi = x^2yz + H(x, y);$$

together, these imply that  $\phi = x^2yz + \text{constant}$ , which is the velocity potential.

---

## 2.2 Helmholtz's equation (the 'vorticity' equation)

We now develop an equation that describes how the vorticity evolves in a flow; this equation is then a counterpart to Euler's equation for the velocity field. Some aspects of fluid flow are better described by a *vorticity equation*, although in this discussion of theoretical fluid mechanics we will continue to emphasise the rôle of  $\mathbf{u}$  rather than  $\boldsymbol{\omega}$ .

Starting with Euler's equation:  $\frac{D\mathbf{u}}{Dt} = -\frac{1}{\rho}\nabla p + \mathbf{F}$ , we assume that the body force,  $\mathbf{F}$ , is *conservative*:  $\mathbf{F} = -\nabla\Omega$ , for some scalar function  $\Omega(\mathbf{x})$ ; the minus sign here is simply a convenience, and we could include dependence on time. (This 'conservative' assumption implies that the work done, in moving from point to point in this force field, depends only on the end-points – not on the path between the points.) In addition, we assume that either  $\rho = \text{constant}$  (as required for our incompressible fluid) or  $p = p(\rho)$  (which is used to model gases).

In this latter case, we write

$$\begin{aligned} \frac{1}{\rho}\nabla p &= \left( \frac{1}{\rho} \frac{\partial p}{\partial x}, \dots, \dots \right) = \left( \frac{\partial p}{\partial x} \frac{d}{dp} \int \frac{dp}{\rho}, \dots, \dots \right) \\ &= \left( \frac{\partial}{\partial x} \int \frac{dp}{\rho}, \dots, \dots \right) = \nabla \left( \int \frac{dp}{\rho} \right); \end{aligned}$$

similarly, in the former case, we simply have  $\frac{1}{\rho}\nabla p = \nabla \left( \frac{p}{\rho} \right) = \nabla \left( \int \frac{dp}{\rho} \right)$ .

We require one further result:  $\mathbf{u} \wedge (\nabla \wedge \mathbf{u}) = \nabla \left( \frac{1}{2} \mathbf{u} \cdot \mathbf{u} \right) - (\mathbf{u} \cdot \nabla) \mathbf{u}$  (see Exercise 7(c)), and we note that  $\nabla \wedge \mathbf{u} = \boldsymbol{\omega}$ .

These three results, used in Euler's equation, give

$$\mathbf{u}_t + (\mathbf{u} \cdot \nabla) \mathbf{u} = \mathbf{u}_t + \nabla \left( \frac{1}{2} \mathbf{u} \cdot \mathbf{u} \right) - \mathbf{u} \wedge \boldsymbol{\omega} = -\nabla \left( \int \frac{dp}{\rho} \right) - \nabla \Omega$$

$$\text{i.e. } \mathbf{u}_t - \mathbf{u} \wedge \boldsymbol{\omega} = -\nabla \left( \frac{1}{2} \mathbf{u} \cdot \mathbf{u} + \int \frac{dp}{\rho} + \Omega \right).$$

Finally, we take the curl (i.e. operate  $\nabla \wedge$ ) of this equation:

$$\nabla \wedge (\mathbf{u}_t) - \nabla \wedge (\mathbf{u} \wedge \boldsymbol{\omega}) = \mathbf{0},$$

because  $\nabla \wedge \nabla \equiv \mathbf{0}$ , and then (see Exercise 7(d)) we use

$$\nabla \wedge (\mathbf{u} \wedge \boldsymbol{\omega}) = \mathbf{u}(\nabla \cdot \boldsymbol{\omega}) + (\boldsymbol{\omega} \cdot \nabla) \mathbf{u} - \boldsymbol{\omega}(\nabla \cdot \mathbf{u}) - (\mathbf{u} \cdot \nabla) \boldsymbol{\omega},$$

where  $\nabla \cdot \boldsymbol{\omega} = \nabla \cdot (\nabla \wedge \mathbf{u}) = 0$  and we assume incompressibility:  $\nabla \cdot \mathbf{u} = 0$ . Thus we obtain

$$\boldsymbol{\omega}_t - (\boldsymbol{\omega} \cdot \nabla) \mathbf{u} + (\mathbf{u} \cdot \nabla) \boldsymbol{\omega} = \mathbf{0} \quad \text{or} \quad \frac{D\boldsymbol{\omega}}{Dt} = (\boldsymbol{\omega} \cdot \nabla) \mathbf{u},$$

which is *Helmholtz's equation*. [H. von Helmholtz (1821-1894), German philosopher, mathematician, physicist and physiologist; also made important contributions to the classification of geometries and the axioms of arithmetic.]

This equation shows that the velocity and vorticity fields are, in general, coupled – which is no surprise. But there is an important special case, with far-reaching consequences: suppose that the flow depends on only two spatial variables,  $x$  and  $y$ , say. Then  $\boldsymbol{\omega}$  and  $\nabla$  are mutually orthogonal, which gives  $\boldsymbol{\omega} \cdot \nabla \equiv 0$ ; thus

$$\frac{D\boldsymbol{\omega}}{Dt} = \mathbf{0}.$$

This equation shows that  $\boldsymbol{\omega}$  does not change on fluid particles (points) as the flow evolves; in particular, the direction of  $\boldsymbol{\omega}$  remains the same: this vector always points in the  $z$ -direction. This phenomenon is usually described as the vorticity being *trapped* perpendicular to the plane of the flow.

**Comment:** This derivation can be generalised, by relaxing some of the simplifications that we have made. Thus, for any fluid (i.e. compressible, satisfying the general equation of mass conservation), it can be shown that

$$\frac{D}{Dt} \left( \frac{\boldsymbol{\omega}}{\rho} \right) = \left( \frac{\boldsymbol{\omega}}{\rho} \cdot \nabla \right) \mathbf{u} - \frac{1}{\rho} \nabla(\rho^{-1}) \wedge \nabla p,$$

and then if  $p = p(\rho)$  this reduces to  $\frac{D}{Dt} \left( \frac{\boldsymbol{\omega}}{\rho} \right) = \left( \frac{\boldsymbol{\omega}}{\rho} \cdot \nabla \right) \mathbf{u}$ , which is our equation above, with  $\boldsymbol{\omega}$  replaced by  $\boldsymbol{\omega}/\rho$ . All this is left as an exercise for the interested reader.

### 2.3 Bernoulli's equation (or theorem)

This equation is a first (spatial) integral of the equation of motion (Euler's equation), producing the familiar *energy integral* for a conservative system. To proceed, we use an approach based on the development described for Helmholtz's equation (§2.2). Thus we assume

(a)  $\mathbf{F} = -\nabla\Omega$  (conservative);

(b)  $\rho = \text{constant}$  or  $p = p(\rho)$ , so that  $\frac{1}{\rho}\nabla p = \nabla\left(\int\frac{dp}{\rho}\right)$ ;

(c) steady flow – a new condition.

Note that the flow may be rotational – we say nothing about  $\boldsymbol{\omega}$  – which makes this analysis quite general and powerful.

From §2.2, we immediately have

$$\mathbf{u}_t - \mathbf{u} \wedge \boldsymbol{\omega} = -\nabla\left(\frac{1}{2}\mathbf{u} \cdot \mathbf{u} + \int\frac{dp}{\rho} + \Omega\right),$$

but with the extra requirement that  $\mathbf{u}_t = \mathbf{0}$  (steady); with this included, we take the dot of the resulting equation with  $\mathbf{u}$ :

$$-\mathbf{u} \cdot (\mathbf{u} \wedge \boldsymbol{\omega}) = -\mathbf{u} \cdot \nabla\left(\frac{1}{2}\mathbf{u} \cdot \mathbf{u} + \int\frac{dp}{\rho} + \Omega\right).$$

Here, we have  $-\mathbf{u} \cdot (\mathbf{u} \wedge \boldsymbol{\omega}) = 0$  (because two of the three terms in this triple are the same); also  $\mathbf{u} \cdot \nabla$  is a directional derivative, the direction being associated with the velocity field i.e. tangent to the streamlines. Thus we have

$$\mathbf{u} \cdot \nabla\left(\frac{1}{2}\mathbf{u} \cdot \mathbf{u} + \int\frac{dp}{\rho} + \Omega\right) = 0 \text{ so that } \frac{1}{2}\mathbf{u} \cdot \mathbf{u} + \int\frac{dp}{\rho} + \Omega = \text{constant on streamlines};$$

this is *Bernoulli's equation* (sometimes called *Bernoulli's theorem*). [D. Bernoulli (1700-1782), one of a family of 10 Swiss mathematicians (over four generations); Daniel obtained his doctorate in medicine and was, at various times, a professor of botany, anatomy, philosophy and mathematics.]

A special case of this result, which we note is essentially algebraic in all cases, arises for incompressible flow ( $\rho = \text{constant}$ ) in the presence of a gravity field ( $\Omega = gz$ ,  $g = \text{constant}$ ):

$$\frac{1}{2}\mathbf{u} \cdot \mathbf{u} + \frac{p}{\rho} + gz = \text{constant on streamlines},$$

and different constants are associated with different streamlines. The terms in this energy integral are, respectively, the kinetic energy, the work done by the pressure forces and the potential energy (all per unit mass). We now use this simple version of Bernoulli's equation in two straightforward, but illuminating examples.

**Example 14a**

*Bernoulli's equation for the pitot-static tube.*

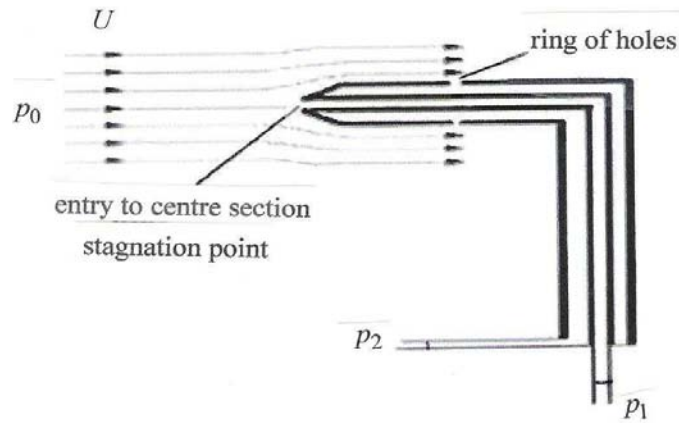

The pitot-static tube is used on aircraft as the device for measuring the airspeed (although some aircraft use only the pitot part of the tube – the central tube – and the static pressure is measured elsewhere on the fuselage). A schematic of the combined pitot and static tube is shown in the figure. We assume that the flow is horizontal (so the body-force term will play no rôle: the flow is on a line of constant  $z$ ) and steady, with constant density. The oncoming flow is of speed  $U$  and pressure  $p_0$ , and on a streamline that approaches the inner tube from infinity, we obtain  $\frac{1}{2}U^2 + \frac{p_0}{\rho} + gz = \frac{p_1}{\rho} + gz$ , because the flow is stationary at the mouth of this part of the tube, at a pressure  $p_1$ . The flow otherwise passes the exterior of the tube, with no flow possible in or out through the ring of holes, recording a pressure  $p_2 = p_0$ . Thus the resulting pressure difference gives  $p_1 - p_2 = \frac{1}{2}\rho U^2$ ; this pressure difference can be delivered to a speed scale, suitably calibrated (knowing  $\rho$ ) to give a measure of the airspeed.

**Example 14b**

*Bernoulli's equation.* A straight pipe through which water ( $\rho = \text{constant}$ ) flows, slopes downwards, dropping through a vertical height of  $h$ . At the upper end the cross-sectional area is  $A$ , the flow speed is  $u_0$  and the pressure is  $P_0$ ; at the lower end the area is  $A/2$ . Find the speed and pressure at the lower end. (Assume that the flow is uniform at every section along the pipe.) What is the necessary condition for this flow to be physically realistic?

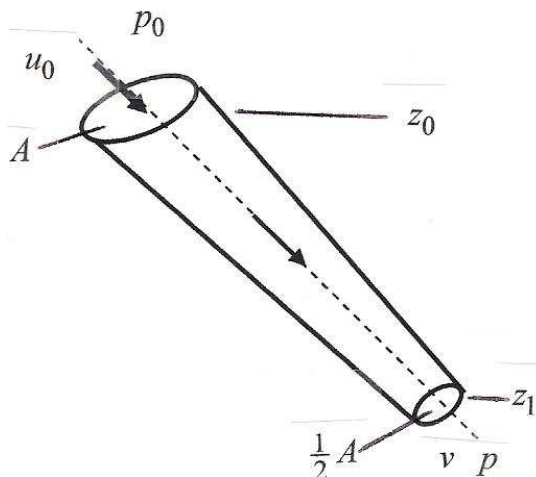

The flow is represented in the figure; to proceed, we first use mass conservation in the form: speed $\times$ area = constant i.e.  $Au_0 = \frac{1}{2}Av$  so  $v = 2u_0$ . Now we apply Bernoulli's equation along a streamline associated with the flow through the pipe:

$$\frac{1}{2}u_0^2 + \frac{p_0}{\rho} + gz_0 = \frac{1}{2}v^2 + \frac{p}{\rho} + gz_1.$$

Thus  $\frac{1}{2}u_0^2 + \frac{p_0}{\rho} + g(z_0 - z_1) - \frac{1}{2}4u_0^2 = \frac{p}{\rho}$ , which gives  $p = p_0 + \rho gh - \frac{3}{2}\rho u_0^2$ .

Any physically realistic flow must have  $p > 0$ , for pressure can never be negative (although it is quite usual to take this condition, in simple theoretical calculations, to be  $p \geq 0$ , because the pressure can drop to almost zero); thus we require

$$p_0 + \rho gh > \frac{3}{2}\rho u_0^2.$$

N.B. If this condition is not satisfied, so that pressure apparently becomes zero or negative, then the model has broken down. In this situation, the fluid will exhibit bubbles of gas coming out of solution: the fluid to be analysed has become a *mixture* (of a liquid and a gas) for which a very different approach is required.

**Comment:** In the two previous examples, we have considered the simplest case:  $\rho = \text{constant}$ , and then  $\int \frac{dp}{\rho} = \frac{p}{\rho}$ . However, for many gas flows, the temperature hardly changes locally (because the heat diffuses relatively slowly), in this situation, called an *adiabatic* process, it can be shown that  $p \propto \rho^\gamma$ , where  $\gamma$  is a constant ( $1 < \gamma < 2$ , and for air  $\gamma \approx 1.4$ ). [‘Adiabatic’ = ‘not’ + ‘pass’, referring to heat.]

On the other hand, if heat is rapidly diffused, so that the temperature equilibrates everywhere quickly, then  $T = \text{constant}$  throughout; if we then also have a *perfect gas*, for which  $p = \rho RT$  ( $R$  constant), we obtain  $p \propto \rho$ .

So with  $p = k\rho^\gamma$  (where  $k$  is a constant, normally fixed from knowing the pressure and density at the same point in the flow), we have

$$\begin{aligned} \int \frac{dp}{\rho} &= \int \frac{dp}{d\rho} \frac{1}{\rho} d\rho = \int k\gamma\rho^{\gamma-2} d\rho \\ &= k\gamma \frac{\rho^{\gamma-1}}{\gamma-1} \quad (\gamma \neq 1) \\ &= \frac{\gamma}{\gamma-1} \frac{p}{\rho} \end{aligned}$$

ENGINEERING, RESEARCH AND OPERATIONS

**85** years of innovation

- > 113,000 employees
- > 140 nationalities
- > 85 countries of operation

**Who are we?**  
We are the world's largest oilfield services company<sup>1</sup>. Working globally—often in remote and challenging locations—we invent, design, engineer, and apply technology to help our customers find and produce oil and gas safely.

**Who are we looking for?**  
We're looking for high-energy, self-motivated graduates with vision to work in our engineering, research and operations domain.

**What will you be?**

careers.slb.com **Schlumberger**

<sup>1</sup> Based on Fortune 500 ranking 2011. Copyright © 2012 Schlumberger. All rights reserved.



**Example 15**

*Flow of a gas.* The flow of a gas (described by  $p = k\rho^\gamma$ ) is described by Bernoulli's equation, in the absence of body forces; show that  $u^2 = (2/(\gamma-1))(a_0^2 - a^2)$ , where  $a = \sqrt{dp/d\rho}$  is the local speed of sound,  $u$  is the speed of the flow and the zero subscript denotes evaluation

where  $u = 0$ .

Here, we have  $\frac{1}{2}\mathbf{u} \cdot \mathbf{u} + \int \frac{dp}{\rho} + 0 = \text{constant}$  and then  $\frac{1}{2}\mathbf{u} \cdot \mathbf{u} + \frac{\gamma}{\gamma-1} \frac{p}{\rho} = \text{constant}$ , with

$$\frac{1}{2}\mathbf{u} \cdot \mathbf{u} = u^2 \quad \text{and} \quad \frac{dp}{d\rho} = k\gamma\rho^{\gamma-1} = \gamma \frac{p}{\rho} = a^2;$$

thus we obtain

$$\frac{1}{2}u^2 + \frac{a^2}{\gamma-1} = \text{const.} = \frac{a_0^2}{\gamma-1} \quad (\text{the value where } u = 0) \quad \text{i.e. } u^2 = \frac{2}{\gamma-1}(a_0^2 - a^2), \text{ as required.}$$

**Comment:** The speed of sound at normal temperature and pressure i.e. at ground level, is about 760 mph; at 35,000 ft (the normal cruising height of most civil aircraft), this speed is about 660 mph. We also note that this final expression, when divided by  $a^2$ , generates the term  $u/a = M$ , the *Mach number* of the flow.

## 2.4 The pressure equation

There is an unsteady counterpart to Bernoulli's equation, valid under slightly different assumptions about the flow field. We start, as in §2.3, with the result used in the derivation of Helmholtz's equation:

$$\mathbf{u}_t - \mathbf{u} \wedge \boldsymbol{\omega} = -\nabla \left( \frac{1}{2}\mathbf{u} \cdot \mathbf{u} + \int \frac{dp}{\rho} + \Omega \right)$$

(so  $\rho = \text{constant}$  or  $p = p(\rho)$  and  $\mathbf{F} = -\nabla\Omega$  i.e. conservative), but now we assume that the flow is *irrotational*:  $\dot{\mathbf{u}} \equiv \mathbf{0} \Rightarrow \mathbf{u} = \nabla\phi$ . Then, for suitable differentiable functions, we have  $\mathbf{u}_t = (\nabla\phi)_t = \nabla(\phi_t)$ , and so we obtain

$$\nabla \left( \frac{\partial\phi}{\partial t} + \frac{1}{2}\mathbf{u} \cdot \mathbf{u} + \int \frac{dp}{\rho} + \Omega \right) = \mathbf{0}$$

which integrates directly to give

$$\frac{\partial \phi}{\partial t} + \frac{1}{2} \mathbf{u} \cdot \mathbf{u} + \int \frac{dp}{\rho} + \Omega = f(t),$$

where  $f(t)$  is an arbitrary function (of time); this is the *pressure equation*.

**Note:** We can always remove the explicit appearance of  $f$  here by redefining  $\phi$  as  $\phi + \int f(t) dt$  (since  $\phi$  is defined only via spatial derivatives). The only slight downside of this reformulation is that the use of, and result of using, boundary conditions are less obvious.

---

This equation is so-called because, given the velocity field, which is equivalent to knowing  $\phi(\mathbf{x}, t)$ , we can find the pressure essentially by an algebraic process. (Some texts may refer to this as the ‘unsteady’ Bernoulli equation – which is certainly how it appears – but this is a serious misnomer: the pressure equation does not describe energy conservation. The equation has an energy-source term,  $f(t)$ , which allows the terms associated with the energy to change in time – but that could be one interpretation of ‘unsteady.’)

**Special case:** If the flow is now taken to be steady, then we obtain

$$\frac{1}{2} \mathbf{u} \cdot \mathbf{u} + \frac{p}{\rho} + gz = \text{constant}, \text{ the same constant everywhere;}$$

for Bernoulli’s equation, this gives different constants on different streamlines (§2.3). The difference between these two integrals then arises by virtue of the vorticity: Bernoulli holds for rotational flows – different constants on different streamlines – but the steady version of the pressure equation is valid for irrotational flow: the same constant everywhere. This is an important observation, showing the consequences of rotational *versus* irrotational flows.

**Example 16**

*Flow out of a container.* A vertical container, of cross-sectional area  $A$  over most of its height, reduces to an area  $\lambda A$  at the base; across the base is placed a removable plate. The container is filled to a depth of  $h_0$  with water ( $\rho = \text{constant}$ ) and the plate is then removed, allowing the water to flow out. Assume that the flow is irrotational but unsteady, and hence find the differential equation for the depth of water,  $h(t)$ , at any time  $t$ . (You may assume that the flow is uniform across every section.)

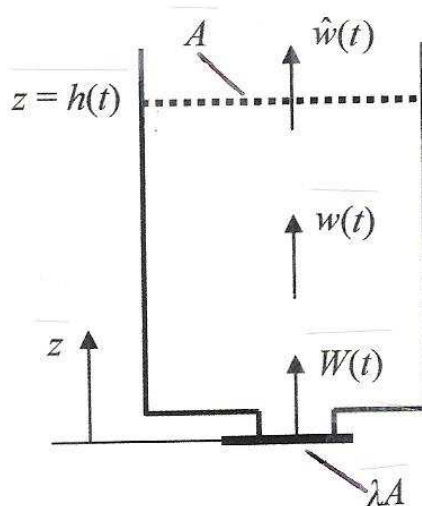

You're full of *energy* and *ideas*. And that's just what we are looking for.

Looking for a career where your ideas could really make a difference? UBS's Graduate Programme and internships are a chance for you to experience for yourself what it's like to be part of a global team that rewards your input and believes in succeeding together.

Wherever you are in your academic career, make your future a part of ours by visiting [www.ubs.com/graduates](http://www.ubs.com/graduates).

[www.ubs.com/graduates](http://www.ubs.com/graduates)



© UBS 2010. All rights reserved.



Because the flow is uniform across every section, we first apply the rule: speed×area = constant, to give  $A\hat{w}(t) = \lambda AW(t)$  ; see the figure. (In passing, we note that  $\nabla \cdot \mathbf{u} = 0$  is satisfied.) The pressure equation gives

$$\frac{\partial \phi}{\partial t} + \frac{1}{2} \mathbf{u} \cdot \mathbf{u} + \frac{p}{\rho} + gz = f(t),$$

where  $w(t) = \phi_z$  i.e.  $\phi = zw(t)$  (because any additive function is absorbed into  $f$ ). Now, at any level in the tank, we have

$$z\dot{w} + \frac{1}{2} w^2 + \frac{p}{\rho} + gz = f(t),$$

and evaluating at the surface:  $z = h$ ,  $w = \hat{w} = \dot{h} (< 0)$ ,  $p = p_0 =$  atmospheric pressure,

we obtain  $h\ddot{h} + \frac{1}{2} \dot{h}^2 + \frac{p_0}{\rho} + gh = f(t)$ .

Correspondingly, evaluating at the exit, with the plate removed, so that the water is also here open to the atmosphere:  $z = 0$ ,  $w = W = \lambda^{-1}\hat{w}$ ,  $p = p_0$ , to give

$$0 + \frac{\dot{h}^2}{2\lambda^2} + \frac{p_0}{\rho} + 0 = f(t)$$

which, together with the previous equation, produce the differential equation for  $h(t)$ :

$$h\ddot{h} + \frac{1}{2}(1 - \lambda^{-2})\dot{h}^2 + gh = 0.$$

The initial conditions are  $h(0) = h_0$ ,  $\dot{h}(0) = 0$ ; this equation is discussed further in Exercise 52.

---

### 2.5 Vorticity and circulation

We now explore the nature and properties of vorticity a little further. First, let us introduce *vortex lines* (just as we considered streamlines): lines which, everywhere, have the vorticity vector as tangent. Often, we are more interested in bundles of vortex lines, rather than individual lines; such a bundle is called a *vortex tube*:

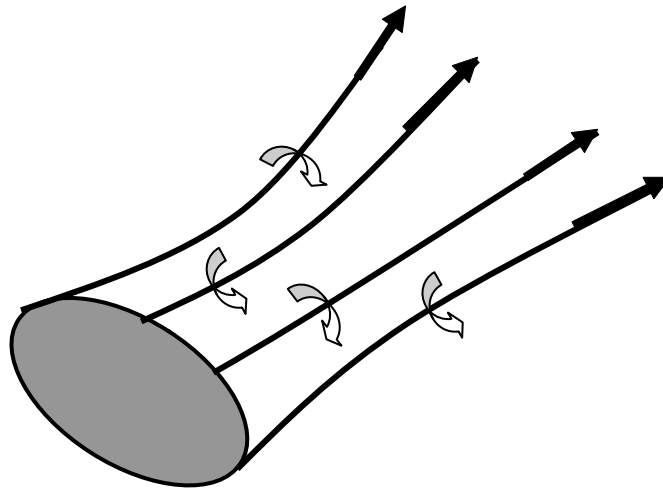

This is the situation that best describes (and represents) the flow down a plug hole and the flow within a tornado, both of which are highly rotational, comprising a bundle of vortex lines.

An important associated property (which plays a significant rôle in aerofoil theory) is the *circulation*. The circulation is defined by

$$K(t) = \oint_C \mathbf{u} \cdot d\mathbf{l}$$

on any simple, closed curve,  $C$ , which encloses an oriented surface  $S$  (with unit normal pointing in the right-hand-screw sense as  $C$  is mapped out); see the figure below:

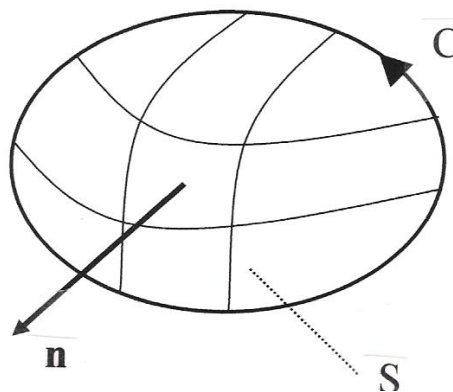

It is the convention to measure the circulation positive in the counter-clockwise, right-hand screw sense. If the geometry is simple, it is possible to calculate the circulation easily and directly, as we now demonstrate.

**Example 17**

*Circulation.* A velocity field, expressed in cylindrical coordinates  $(r, \theta, z)$ , is  $\mathbf{u} \equiv (0, \alpha/r, 0)$ , where  $\alpha$  is a constant. Find the circulation around a circle with axis along the  $z$ -coordinate. [This flow is called a *line vortex* - more later.]

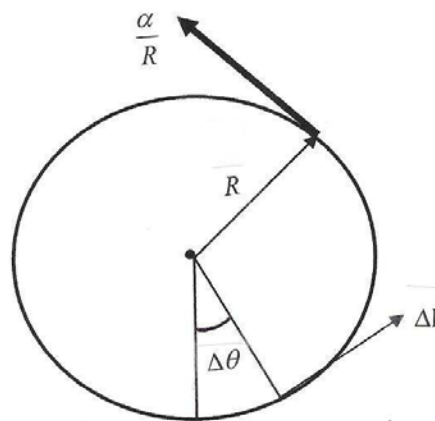

For this flow, on a circle of radius  $R$ , we have

$$\mathbf{u} = \frac{\alpha}{R} \mathbf{e}_\theta \quad \text{and} \quad \Delta \mathbf{l} = R \Delta \theta \mathbf{e}_\theta$$

where  $\mathbf{e}_\theta$  is a unit vector in the direction of increasing  $\theta$ ; both the velocity vector and the (vectorial) element of length around the circle are in the same direction. Thus

$$\mathbf{u} \cdot \Delta \mathbf{l} = \frac{\alpha}{R} R \Delta \theta,$$

and so we obtain  $K = \int_0^{2\pi} \alpha \, d\theta = 2\pi\alpha$ : the circulation is independent of the radius  $R$ .

Note: The vorticity for this velocity field is  $\mathbf{u} = \mathbf{0}$ ,  $r > 0$ , but it is undefined on  $r = 0$ .

We now turn to another aspect of circulation, by finding an alternative – and very illuminating – expression for it: an application of Stokes' Theorem produces

$$\oint_C \mathbf{u} \cdot d\mathbf{l} = \int_S \nabla \wedge \mathbf{u} \cdot \mathbf{n} ds = \int_S \boldsymbol{\omega} \cdot \mathbf{n} ds,$$

which is a measure of all the vorticity passing *through* the surface  $S$ , bounded by the curve  $C$ . (Consider the nature of a tornado, from the broad, slow-moving cloud base, down to the high-speed rotation near the ground. This is a vortex tube, and the surface  $S$  could be taken either across the broad cloud base or across the narrow tube near the ground. )

We now obtain two important, general results that relate to circulation.



Do you have to be a banker to **work** in investment banking?

Deutsche Bank  
[db.com/careers](https://www.db.com/careers)

---

Agile minds **value ideas** as well as experience

---

**Global Graduate Programs**

Ours is a complex, fast-moving, global business. There's no time for traditional thinking, and no space for complacency. Instead, we believe that success comes from many perspectives — and that an inclusive workforce goes hand in hand with delivering innovative solutions for our clients. It's why we employ 135 different nationalities. It's why we've taken proactive steps to increase female representation at the highest levels. And it's just one of the reasons why you'll find the working culture here so refreshing.

Discover something different at [db.com/careers](https://www.db.com/careers)

*Passion to Perform*



**(a) Circulation along a vortex tube**

Consider a vortex tube, and two stations (positions) along it, defined by taking slices across the tube:

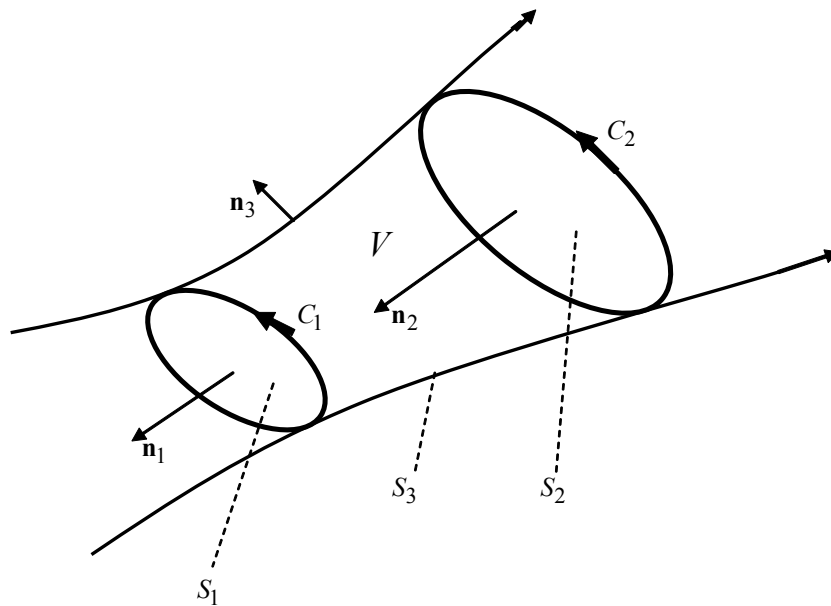

Here, there is a volume  $V$  bounded by the surface constructed from  $S = S_1 + S_2 + S_3$  (the two ends of the region, and the section of vortex tube between them). Consider  $\int_S \boldsymbol{\omega} \cdot \mathbf{n} \, ds$ ; we apply the Divergence (Gauss') theorem to give

$$\int_S \boldsymbol{\omega} \cdot \mathbf{n} \, ds = \int_V \nabla \cdot \boldsymbol{\omega} \, dv = 0,$$

because  $\nabla \cdot \boldsymbol{\omega} = \nabla \cdot (\nabla \wedge \mathbf{u}) = 0$  for all  $\mathbf{u}$ . We now express the surface integral as the sum of integrals over the three surfaces that comprise  $S$ :

$$\int_{S_1} \boldsymbol{\omega} \cdot \mathbf{n}_1 \, ds + \int_{S_2} \boldsymbol{\omega} \cdot (-\mathbf{n}_2) \, ds + \int_{S_3} \boldsymbol{\omega} \cdot \mathbf{n}_3 \, ds = 0,$$

where we have used the correct directions for the unit normals outward on each part of  $S$ . But  $\boldsymbol{\omega}$  and  $\mathbf{n}_3$  are mutually orthogonal on  $S_3$ , so this integral is zero, leaving

$$\int_{S_1} \boldsymbol{\omega} \cdot \mathbf{n}_1 \, ds = \int_{S_2} \boldsymbol{\omega} \cdot \mathbf{n}_2 \, ds \text{ or } K_1 = K_2,$$

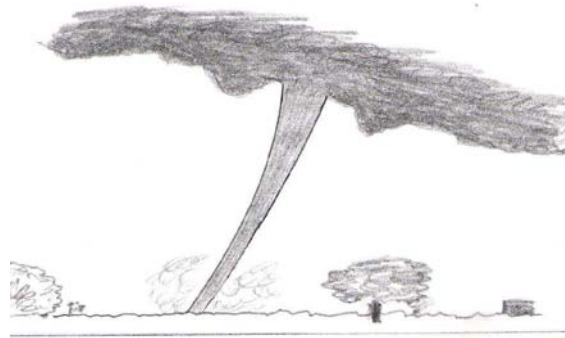

when we introduce the circulation at the two stations. Thus the circulation along a vortex tube remains constant. In particular, if the cross-sectional area of the tube decreases, then  $|\omega|$  must increase in order to maintain the constancy; this has important consequences for a tornado: as the area decreases (as observed near the ground) the speed of rotation increases dramatically.

**(b) Kelvin’s circulation theorem (1869)**

This involves the computation of the circulation,  $K$ , around a simple, closed contour that always contains the same fluid particles i.e. the contour moves with the fluid, as the fluid moves and distorts. This calculation (see Appendix 4) leads to the result  $\frac{dK}{dt} = 0$ : the circulation does not change on the same fluid particles. Thus, for example, if the flow is initially irrotational, so that  $K = 0$  for every choice of contour, it will remain so for all time. (We must note that this is true only for an inviscid (model) fluid; viscosity changes this picture altogether, because one of the actions of viscosity is to generate vorticity.)

**2.6 The stream function**

This is the final, general, property that we discuss here. Let us restrict the motion so that variations occur only in two spatial dimensions ( $(x, y)$  say), which will often be the situation in the geometries that we discuss. The flow may still be unsteady. For an incompressible flow, we have

$$u_x + v_y = 0,$$

using rectangular Cartesian components (but other systems are possible); let us introduce  $\widehat{\psi}(x, y, t)$  such that  $u = \widehat{\psi}_y$ . The equation of mass conservation then becomes

$$\widehat{\psi}_{xy} + v_y = 0 \text{ and so } v = -\widehat{\psi}_x + h(x, t),$$

where  $h$  is an arbitrary function; we write this last as

$$v = -\frac{\partial}{\partial x} \left( \widehat{\psi} - \int h(x, t) dx \right).$$

It is convenient, now, to define  $\psi(x, y, t) = \widehat{\psi} - \int h(x, t) dx$ , to give

$$u = \psi_y \quad \text{and} \quad v = -\psi_x.$$

Thus, for arbitrary (twice differentiable) functions  $\psi(x, y, t)$ , we have satisfied ('solved') the equation of mass conservation for a 2D, incompressible fluid (which may be both unsteady and rotational); but what is  $\psi$ ?

Consider lines  $\psi(x, y, t) = k(t)$  at fixed  $t$ ; we assume that this relation defines  $y = y(x, t)$ , and then we form (all at fixed  $t$ )

$$\frac{d}{dx} \psi(x, y(x, t), t) = 0 \quad \text{i.e.} \quad \psi_x + \psi_y \frac{dy}{dx} = 0 \quad \text{or} \quad \frac{dy}{dx} = -\frac{\psi_y}{\psi_x} = \frac{v}{u}.$$

But this last statement is the definition, in 2D, of the streamlines (defined at an instant in time); see (§1.2.1). Thus lines  $\psi(x, y, t) = k(t)$ , at fixed  $t$ , are the streamlines; consequently, we call  $\psi$  the *stream function*.

**Note:** In plane polar coordinates, we have the equation of mass conservation ( $\nabla \cdot \mathbf{u} = 0$ ) in the form

$$\frac{\partial}{\partial r}(ru) + \frac{\partial v}{\partial \theta} = 0 \quad \text{and so we define} \quad u = \frac{1}{r} \frac{\partial \psi}{\partial \theta}, \quad v = -\frac{\partial \psi}{\partial r}.$$

Correspondingly, in cylindrical coordinates with axi-symmetry, we have

$$\frac{1}{r} \frac{\partial}{\partial r}(ru) + \frac{\partial w}{\partial z} = 0 \quad \text{and so here we define} \quad u = \frac{1}{r} \frac{\partial \psi}{\partial z}, \quad w = -\frac{1}{r} \frac{\partial \psi}{\partial r}.$$

We now explore two simple examples that involve the stream function.

### **Example 18**

*Stream function I.* Given that  $\mathbf{u} \equiv (\alpha x, -\alpha y)$ , where  $\alpha$  is a constant, find the stream function,  $\psi$ .

---

We first check that  $\nabla \cdot \mathbf{u} = u_x + v_y = 0$ , which follows directly, so  $\psi$  exists; thus  $u = \psi_y = \alpha x$ ,  $v = -\psi_x = -\alpha y$  and so  $\psi = \alpha xy$  is the stream function (and remember that any additive constant is irrelevant).

---

**Example 19**

*Stream function II.* A simple model for a vortex is described by  $\mathbf{u} \equiv (0, -K/r)$ , expressed in plane polars, where  $K$  is a constant; find  $\psi(r, \theta)$ .

Here, we require  $\nabla \cdot \mathbf{u} = (ur)_r + v_\theta = 0$ , which is clearly true, so  $\psi$  exists; thus

$$u = \frac{1}{r} \psi_\theta = 0, v = -\psi_r = -\frac{K}{r} \text{ and so } \psi = -K \ln r \text{ is the stream function.}$$

**Comment:** Let us now suppose that this 2D flow is also irrotational, then we obtain

$$\mathbf{u} = (0, 0, v_x - u_y) = (0, 0, -\psi_{xx} - \psi_{yy}) = \mathbf{0};$$

thus  $\psi$  satisfies Laplace's equation. On the other hand, suppose, first, that the 2D flow is irrotational, then  $\boldsymbol{\omega} = \nabla \wedge \mathbf{u} = \mathbf{0} \Rightarrow \mathbf{u} = \nabla \phi$  i.e.  $\mathbf{u} = \nabla \phi = (\phi_x, \phi_y, 0)$ ; see §2.1. Then, if the flow is also incompressible ( $\nabla \cdot \mathbf{u} = 0$ ), we obtain

$$\phi_{xx} + \phi_{yy} = 0 \quad (\nabla^2 \phi = 0) \text{ - Laplace's equation again.}$$

**Real drive. Unreal destination.**

As an intern, you're eager to put what you've learned to the test. At Ernst & Young, you'll have the perfect testing ground. There are plenty of real work challenges. Along with real-time feedback from mentors and leaders. You'll also get to test what you learn. Even better, you'll get experience to learn where your career may lead. Visit [ey.com/internships](http://ey.com/internships).

See More | Opportunities

© 2012 Ernst & Young LLP. All Rights Reserved.

**ERNST & YOUNG**  
Quality In Everything We Do



In summary, therefore, we have, for two dimensional, incompressible, irrotational flow

$$u = \phi_x = \psi_y \text{ and } v = \phi_y = -\psi_x,$$

which are the Cauchy-Riemann relations relating  $\phi$  and  $\psi$ . Thus there is a (differentiable) function  $w(Z, t)$  such that

$$w(Z, t) = \phi(x, y, t) + i\psi(x, y, t) \text{ (where } Z = x + iy \text{),}$$

and then the techniques of complex analysis become available. We shall return to this later, and make considerable use of this important idea.

## 2.7 Kinetic energy and a uniqueness theorem

In this final section of the chapter, we introduce the total *kinetic energy* of the fluid. Although this is of some importance in more general studies of fluids, we use it here only as a device for developing the notion of *uniqueness*. We define the kinetic energy as

$$T = \frac{1}{2} \int_V \rho \mathbf{u} \cdot \mathbf{u} \, dv,$$

and, if the reader has met the classical kinetic energy of a particle, it is evident that this takes the familiar form:  $\frac{1}{2}mv^2$ . In the fluid, this is defined for the (finite amount of) fluid in the volume  $V$ , bounded by the surface  $S$ , at any instant in time. To proceed (particularly with our view to describing uniqueness), let us assume that the flow is irrotational; thus  $\mathbf{u} = \nabla \phi$ , and then we choose to write

$$T = \frac{1}{2} \int_V \rho (\mathbf{u} \cdot \nabla \phi) \, dv.$$

Further, we suppose that the flow is also incompressible, in which case we have

$$\nabla \cdot [(\rho \phi) \mathbf{u}] = (\rho \phi) \nabla \cdot \mathbf{u} + \mathbf{u} \cdot \nabla (\rho \phi) = \rho \mathbf{u} \cdot \nabla \phi$$

because  $\nabla \cdot \mathbf{u} = 0$  and  $\rho = \text{constant}$ . (Both irrotationality and incompressibility can be ignored in more general discussions of the energy in a flow.) We use this result in our version of the kinetic energy, and then use the Divergence (Gauss') theorem:

$$T = \frac{1}{2} \int_V \rho (\mathbf{u} \cdot \nabla \phi) \, dv = \frac{1}{2} \int_V \nabla \cdot (\rho \phi \mathbf{u}) \, dv = \frac{1}{2} \int_S \rho \phi \mathbf{u} \cdot \mathbf{n} \, ds.$$

In this expression for  $T$ , we see that the energy is now determined by the values of  $\phi$  and  $\mathbf{u}$  on the boundary  $S$ , replacing the evaluation throughout  $V$ . The crucial observation for us is that an evaluation throughout a region has been replaced by an evaluation on the boundary of the region. This idea provides us with a (mathematical) basis for a fundamentally important result: uniqueness.

The issue, now, is the following. Suppose that we have some fluid flow – here, simplified to be both irrotational and incompressible – and some suitable boundary conditions: what form should the boundary conditions take (if any exist at all) that will guarantee that the solution is unique? That is, so that there is just one solution of the complete problem. We must hope that our studies are particular examples of unique flows (although there are many problems in fluids which oscillate between two or more different solutions: some solutions based on suitable models can lead to non-uniqueness).

Consider a general incompressible, irrotational flow, with some given conditions – yet to be determined – on the boundary of the flow field. Let the totality of the field be the volume  $V$ , with a boundary  $S$ . Suppose that there are two possible flows satisfying the equations and boundary conditions; let these flows be designated  $\mathbf{u}_1 = \nabla \phi_1$  and  $\mathbf{u}_2 = \nabla \phi_2$ . We aim to show that the only possibility is  $\mathbf{u}_1 \equiv \mathbf{u}_2$  everywhere, which is uniqueness of the velocity field. Define  $\mathbf{U} = \mathbf{u}_1 - \mathbf{u}_2$  and  $\Phi = \phi_1 - \phi_2$ , and form (by following the idea above)

$$\int_V |\mathbf{U}|^2 dv = \int_V \mathbf{U} \cdot \mathbf{U} dv = \int_V \mathbf{U} \cdot \nabla \Phi dv = \int_S \Phi \mathbf{U} \cdot \mathbf{n} ds.$$

Any particular problem will be defined by the governing equations (e.g. Euler's equation and mass conservation) together with boundary conditions (and note that initial data does not appear here). With prescribed conditions on the boundary, all possible solutions must satisfy this given data so, on  $S$ , we have  $\mathbf{U} \cdot \mathbf{n} = 0$  (if  $\mathbf{u} \cdot \mathbf{n}$  is given on  $S$ ) and  $\Phi = 0$  (if  $\phi$  is given on  $S$ ). (The more usual is  $\mathbf{u} \cdot \mathbf{n}$  i.e. we know the normal velocity of the fluid on the boundary, and typically this is zero: the boundary is solid and stationary.) We deduce, therefore, that if, on  $S$ , either  $\mathbf{u} \cdot \mathbf{n}$  is given, or  $\phi$  is given – we could have one or the other on different parts of  $S$  – then we obtain

$$0 = \int_S \Phi \mathbf{U} \cdot \mathbf{n} ds = \int_V |\mathbf{U}|^2 dv \Rightarrow \mathbf{U} \equiv \mathbf{0} \Rightarrow \mathbf{u}_1 \equiv \mathbf{u}_2.$$

Thus the velocity field is unique – there is one, and only one, flow field – and then, from Euler's equation, we can find the corresponding unique pressure field (up to an arbitrary constant, and this can be identified with, for example, the constant, background atmospheric pressure).

Exercises 2

36. *Incompressibility & vorticity.* For these flows, determine if they are incompressible and find the vorticity vector:

(a)  $\mathbf{u} \equiv (3z + 4x, -5y, -2x + z)$ ; (b)  $\mathbf{u} \equiv (u_0(a^2 - y^2 - z^2), 0, 0)$  ( $u_0, a$  constants).

37. *Vorticity I.* An incompressible velocity field, written in cylindrical coordinates  $(r, \theta, z)$ , is

$$\mathbf{u} \equiv \begin{cases} (0, \omega r, 0), & 0 \leq r \leq a \\ (0, \omega a^2 / r, 0), & r > a \end{cases} \quad (\omega \text{ constant}).$$

(a) Find the vorticity vector for this flow.

(b) In the absence of body forces (and noting that the flow is steady), use Euler’s equation to find the (continuous) pressure which satisfies  $p \rightarrow p_0$  as  $r \rightarrow \infty$ . What is the condition which ensures a realistic pressure everywhere? [This is called the *Rankine vortex*.]

(Remember to use cylindrical coordinates throughout.)

38. *Vorticity II.* Repeat Ex. 37 for the velocity field

$$\mathbf{u} \equiv \begin{cases} (0, \omega r^2 / a, 0), & 0 \leq r \leq a, \\ (0, \omega a^2 / r, 0), & r > a. \end{cases}$$

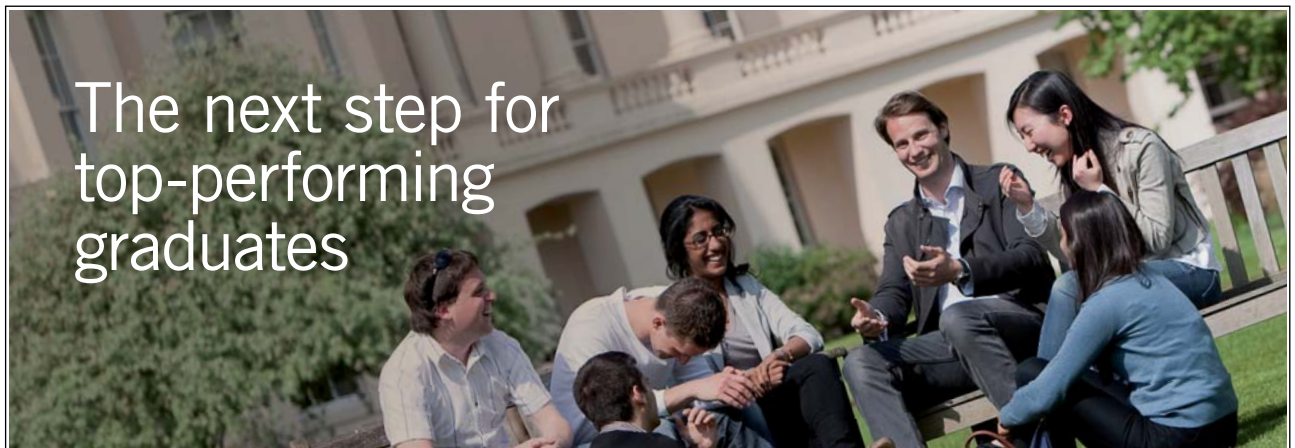

The next step for top-performing graduates

**Masters in Management**



Designed for high-achieving graduates across all disciplines, London Business School’s Masters in Management provides specific and tangible foundations for a successful career in business.

This 12-month, full-time programme is a business qualification with impact. In 2010, our MiM employment rate was 95% within 3 months of graduation\*; the majority of graduates choosing to work in consulting or financial services.

As well as a renowned qualification from a world-class business school, you also gain access to the School’s network of more than 34,000 global alumni – a community that offers support and opportunities throughout your career.

For more information visit [www.london.edu/mm](http://www.london.edu/mm), email [mim@london.edu](mailto:mim@london.edu) or give us a call on +44 (0)20 7000 7573.

\* Figures taken from London Business School’s Masters in Management 2010 employment report



39. *Velocity potential I.* Given that  $\boldsymbol{\omega} = \nabla \wedge \mathbf{u} = \mathbf{0}$ , write this out in component form (in  $(x, y, z)$  coordinates) and hence deduce that the general solution is  $\mathbf{u} = \nabla \phi$ , for arbitrary  $\phi(x, y, z, t)$ . [Hint: Write, for example,  $u = \partial \phi / \partial x$  and integrate; an alternative method is to use an integral theorem.]
40. *Velocity potential II.* See Ex. 25; show that this flow is irrotational and hence find its velocity potential.
41. *Branching pipe flow.* See Ex. 30; the pressure where the area is  $A$  is  $p_0$ ; find the pressure in the two branches of the pipe. [Hint: Consider two separate streamlines, one into each branch (and ignore body forces).]
42. *Another pipe flow.* A pipe varies in cross-sectional area, from  $9A$  to  $A$  to  $3A$ . A fluid of constant density flows uniformly through the pipe, with speed  $u_0$  at area  $9A$ ; find the speeds at areas  $A$  and  $3A$ . The pipe is placed horizontally, and the pressure is  $p_0$  at area  $9A$ ; find the pressures at areas  $A$  and  $3A$ , and state the condition for all pressures to be positive.
43. *Raising water.* Water (so incompressible) flows along a horizontal pipe, which has a contraction to area  $A$  and then enlarges to area  $nA$  further along, at which point the water is delivered at atmospheric pressure. Given that the flow is steady, and uniform across every section, show that a side tube connected to the pipe at the contraction can raise water (at atmospheric pressure) from a depth of  $(Q^2 / 2A^2 g)(1 - n^{-2})$ , where  $Q$  is the volumetric flow rate along the tube.
44. *Flow in an inclined pipe.* A straight pipe of varying cross-sectional area, slopes downwards, dropping through a vertical height of  $h$ ; through it flows an incompressible (constant density) fluid under gravity. At the upper, the area of the pipe is  $A_0$ , the speed is  $u_0$  and the pressure is  $p_0$ ; the flow is assumed to be uniform across every section. At the lower end the area is  $A_1$ ; find the speed and pressure in the flow here.

At a general position, which is at a vertical height  $z$  above the lower end where the area is  $A(z)$ , find the speed,  $u(z)$ , of the flow; now use Bernoulli's equation to find an expression for  $dp/dz$  and show that this gives a local maximum for  $p(z)$  if  $AA'' < 3(A')^2$  (at this point).

45. *Maximum flow along a river.* A uniform (i.e. no variation of speed,  $u$ , with depth), steady flow moves along a horizontal channel – a river or canal – of unit width and depth  $h$ . The bottom streamline has a 'total head'  $H$  which is constant; this is the constant in Bernoulli's equation, with the pressure measured relative to the atmospheric pressure at the surface. Use the vertical component of the hydrostatic pressure equation to find the pressure (in terms of  $h$ ) that appears in Bernoulli's equation. Now show that there is a maximum mass flow rate ( $m = \rho u h$ ), given by  $m = \frac{\rho}{g} \sqrt{\frac{8H^3}{27}}$ , and that this occurs when  $u = \sqrt{gh}$ .
46. *Hydraulic jump.* Suppose that a flow of water suffers a dramatic change in depth (as occurs, for example, in the flow that has passed over a weir; see also the flow from a tap into a basin). Let the depth, at any position, be  $h$  and the speed in the flow (independent of depth) is correspondingly  $u$ . The mass conservation and Euler's equations (written in non-dimensional form) imply that the change in the values of  $hu$  and of  $hu^2 + \frac{1}{2}h^2$  are zero across the change in depth (usually called a *jump*). If the conditions on one side are  $h = h_0$ ,  $u = u_0$ , deduce that, on the other side of the jump where  $h = Hh_0$ , then either  $H = 1$  (no jump) or  $H = \frac{1}{2} \left( -1 + \sqrt{1 + 8F^2} \right)$  with  $F = u_0 / \sqrt{gh_0} > 1$ . Finally, using this information, deduce that the change in energy (given by the change in  $\frac{1}{2}hu^3 + uh^2$ ) is negative: energy is lost through the jump.

[F is the *Froude number*, named after W. Froude (1810-79), naval engineer.]

47. *Flow of a gas.* The local speed of sound in a gas is given by  $\sqrt{dp/d\rho}$  ( $= a$ ), where  $p(\rho)$  describes the gas; we take  $p = k\rho^\gamma$  ( $k, \gamma$  constants) and write the speed at any station as  $u$ . Use Bernoulli's equation (in the absence of body forces) to show

$$\text{(a) that } \frac{1}{2}u^2 + \left(\frac{\gamma}{\gamma-1}\right)\frac{p}{\rho} = \text{constant; (b) and then that } \frac{a^2}{a_0^2} = \left(1 + \frac{1}{2}(\gamma-1)M^2\right)^{-1},$$

where  $M = u/a$  is the (local) *Mach number*, and the zero subscript denotes evaluation where  $u = 0$ .

Now find corresponding expressions for (c)  $\rho/\rho_0$  and (d)  $p/p_0$ . Given, further, that  $p = \rho RT$  ( $R$  constant), find an expression for (e)  $T/T_0$ .

[E. Mach (1838-1916), Austrian physicist and philosopher.]

48. *Expanding gas.* (a) A vessel contains a gas which is maintained at the pressure  $np_0$ , which is then allowed to escape through a small-diameter pipe into the atmosphere (pressure  $p_0$ ). The gas is described by  $p = k\rho^\gamma$  ( $k, \gamma$  constants) with  $\rho = \rho_0$  at pressure  $p_0$ ; find the density at pressure  $np_0$ . Ignore body forces and assume that the speed of the gas inside the vessel is negligible; hence show that the speed of efflux of the gas is  $u = \sqrt{\frac{2\gamma}{\gamma-1} \frac{p_0}{\rho_0} (n^{(\gamma-1)/\gamma} - 1)}$ .

(b) Given, further, that  $p = \rho RT$  ( $R$  constant), find an expression for the temperature ( $T$ ) of the escaping gas in terms of  $T_0$ , the temperature inside the vessel, and  $M = u/a$  (see Ex. 47). Explain the significance of this result. [This is called the *Joule-Thomson effect*.]

49. *Subsonic/supersonic flow.* A gas flows horizontally (so the body force – gravity – can be ignored) along a variable-area pipe. At any station, the density is  $\rho$ , the (uniform) speed is  $u$  and the area is  $A$ ; mass conservation then requires that  $\rho u A = \text{constant}$ . The gas is described by  $p = k\rho^\gamma$  ( $k, \gamma$  constants). Treat  $\rho, p$  and  $u$  as functions of  $A$ ; find expressions for  $d\rho/dA$  from both the mass conservation and Bernoulli's equations, then eliminate  $d\rho/dA$  to show that  $(M^2 - 1) \frac{du}{dA} = \frac{u}{A}$ , where  $M$  is the (local) Mach number (see Ex. 47). For  $u > 0$  (and  $A > 0$ ), deduce that (a) the speed in the pipe decreases as  $A$  increases provided  $M < 1$  (as expected?); (b) the speed *increases* as  $A$  increases if  $M > 1$ !

[This is the basis for the production of supersonic flow ( $M > 1$ ) in the laboratory.]

50. *Incompressibility.* See Ex. 47 (d) (and (b)); show that, for small  $M$ , we have (approximately)  $\frac{p}{\rho_0} + \frac{1}{2}u^2 = \frac{p_0}{\rho_0}$ , which is the incompressible result.

[For air under normal conditions, we find from this result that compressibility effects produce an error of only about 2 % in Bernoulli's equation even at 300 mph.]

51. *Lift from a simple aerofoil.* Use Bernoulli's equation, in the absence of body forces, to find the lift (per unit span) on a two-dimensional aerofoil which is placed parallel to the oncoming stream (speed  $u_0$  and pressure  $p_0$ , at infinity). The aerofoil has a chord (the distance from leading to trailing edge)  $c$ , and is so shaped that the speed of the flow on the lower surface is  $u = u_0 = \text{constant}$ . On the upper surface, the corresponding speed increases linearly from  $u_0$  at the leading edge to  $ku_0$  ( $k > 1$ ) at a distance  $c/4$  from the leading edge; thence it decreases linearly, returning to the value  $u_0$  at the trailing edge. Assume that the thickness of the aerofoil may be ignored, and hence show that the lift per unit span is  $\frac{1}{6}\rho u_0^2 c(k-1)(k+2)$ .

52. *Solution for vertical container.* The equation taken from Example 16 is

$$h\ddot{h} + \frac{1}{2}\dot{h}^2 + gh = \frac{1}{2}\lambda^{-2}\dot{h}^2,$$

for which we seek a solution  $(\dot{h})^2 = f(h)$ . Hence find the equation relating  $\dot{h}$  and  $h$ ; in the case  $\lambda = 1/\sqrt{3}$ , find  $h(t)$  and show that the vessel empties in the time  $t = \pi\sqrt{\frac{h_0}{2g}}$ , where  $h(0) = h_0$  and  $\dot{h}(0) = 0$ .

53. *Oscillating pressure.* The radius of a sphere immersed in an infinite ocean of an incompressible (density  $\rho$ ), inviscid fluid varies according to the equation  $r = r_0 + a \cos nt$ , where  $r_0$  ( $> 0$ ),  $a$  and  $n$  are constants. The fluid moves radially, in the absence of body forces; the pressure in the fluid at infinity is  $p_0$ . Assume that the velocity potential for the motion of the fluid is given by  $\phi = F(t)/r$ , find  $F(t)$  (by considering the motion at the surface of the sphere) and then use the pressure equation to find the pressure on the sphere at any instant in time. Hence show that the maximum pressure attained is  $p = p_0 + \rho n^2 a \left(\frac{3}{2}a + \frac{1}{10}\left(\frac{r_0^2}{a}\right)\right)$  (given that  $r_0 \leq |5a|$ ).



54. *Collapse of a spherical cavity.* A flow is produced by the formation, and then collapse, of a spherical cavity in an incompressible (density  $\rho$ ), irrotational fluid, which is at rest at infinity where the pressure is  $p_0$ . We are given the existence of the cavity, with an initial radius of  $a$  which always maintains an internal pressure  $p_1$  ( $< p_0$ ). As the cavity collapses, the fluid motion is purely radial with radial speed throughout the fluid  $u = \partial\phi/\partial r$ , where  $\phi = F(t)/r$ . First evaluate on the surface of the cavity, which enables  $F(t)$  to be determined in terms of the radius of the cavity,  $r = r_0(t)$ . Ignore body forces and then show that the pressure equation gives

$$\frac{1}{r_0} \frac{d}{dt} \left( r_0^2 \frac{dr_0}{dt} \right) - \frac{1}{2} \left( \frac{dr_0}{dt} \right)^2 + \frac{p_0}{\rho} = \frac{p_1}{\rho}.$$

Hence show that this equation can be integrated to give

$$\left( \frac{dr_0}{dt} \right)^2 = \frac{2(p_0 - p_1)}{3\rho} \left[ \left( \frac{a}{r_0} \right)^3 - 1 \right].$$

55. *Streamlines & equipotential lines.* A line (surface) on which  $f(x, y, z) = \text{constant}$  has  $\nabla f$  as its normal. For two-dimensional, incompressible, irrotational flow there exists both a stream function,  $\psi$ , and a velocity potential,  $\phi$ . By considering the form of  $(\nabla\psi) \cdot (\nabla\phi)$ , deduce that lines  $\phi = \text{constant}$  (equipotential lines) are everywhere orthogonal to the streamlines.

[Hint: write in terms of the velocity components.]

56. *Circulation I.* See Ex. 37; find the circulation for this (model) vortex for (a)  $r \leq a$ ; (b)  $r > a$ . Sketch the graph of this circulation, for  $0 \leq r < \infty$ .

57. *Circulation II.* Repeat Ex. 56 for the problem given in Ex. 38.

58. *Kelvin's circulation theorem.* A simple, closed contour,  $C(t)$ , associated with fluid particles in a flow, is described by  $\mathbf{x}(s, t) = (a \cos s + a\lambda t \sin s, a \sin s, 0)$ , for  $t \geq 0$ , where  $a$  and  $\lambda$  are constants and  $0 \leq s \leq 2\pi$  maps out  $C$ . Find  $\mathbf{u}(s, t)$  and state what happens to the points labelled by  $s = 0$ ,  $s = \pi$ . Show that  $\mathbf{u} = (\lambda y, 0, 0)$ . Introduce the circulation,  $K(t)$ , evaluate it for this flow and confirm that  $K$  is independent of  $t$ .

59. *Hill's spherical vortex.* Assume an incompressible flow, described in cylindrical polar coordinates with axisymmetry; thus the stream function,  $\psi(r, z)$ , generates the velocity components  $u = \frac{1}{r} \psi_z$ ,  $w = -\frac{1}{r} \psi_r$ . Write

$$\psi(r, z) = \begin{cases} Ar^2(a^2 - r^2 - z^2), & 0 \leq \sqrt{r^2 + z^2} \leq a \\ \frac{Br^2}{(r^2 + z^2)^{3/2}} - \frac{1}{2}Ur^2, & \sqrt{r^2 + z^2} > a, \end{cases}$$

where  $A, B$  and  $U$  are constants. [The term in  $B$  is a dipole at the centre.]

- (a) Find  $u$  and  $w$ , and then the vorticity, in the region  $0 \leq \sqrt{r^2 + z^2} < a$ . Choose  $A$  so that the vorticity attained as  $r \rightarrow a$  is  $\omega$  (= constant); what is the vorticity at  $r = 0$ ?
- (b) Find  $u$  and  $w$  in the region  $\sqrt{r^2 + z^2} > a$ ; what is the flow at infinity i.e. as  $r^2 + z^2 \rightarrow \infty$ ? [If the flow at infinity is given as zero, then the vortex will move at the speed you have just found.]
- (c) Find the vorticity in the region  $\sqrt{r^2 + z^2} > a$ .
- (d) Determine  $B$  so that  $\psi$  is continuous at the surface of the sphere (where  $r^2 + z^2 = a^2$ ); now find the condition which ensures that the velocity on the sphere is continuous.
- (e) Use some appropriate software (e.g. MAPLE) to plot the streamlines. To do this, take a normalized form:  

$$\psi = \frac{1}{2}r^2(1 - r^2 - z^2) \text{ for } r^2 + z^2 \leq 1; \psi = \frac{1}{3}r^2 \left[ (r^2 + z^2)^{-3/2} - 1 \right] \text{ for } r^2 + z^2 > 1,$$

and select e.g.  $\psi = n/64$  ( $n = 0, 1, \dots, 8$ ) inside, and  $\psi = -n/50$  ( $n = 0, 1, \dots, 15$ ) outside. Then, to plot a section through the vortex ring, use  $-1 \leq r \leq 1$  inside, and  $-1.5 \leq r \leq 1.5, -2 \leq z \leq 2$ , outside.

[This exact solution corresponds closely to that seen in a ring vortex e.g. a smoke ring.]

\*\*\*\*\*

# 3 Viscous Fluids

Any study of fluid mechanics that aims to cover all the physical and mathematical aspects of the subject must include a discussion of *viscous flow*. In the final analysis, it is these ideas that underpin the subject, and enable a very detailed and accurate study of real flows. The important new ingredient – viscosity – leads to a new governing equation: the *Navier-Stokes equation*; this is the viscous counterpart of Euler’s equation. It is beyond the scope of this text to provide a mathematically complete derivation of this equation – which would involve a discussion of stresses and the use of the tensor calculus – but we can outline the thinking behind the equation. (The interested reader will be able to find derivations, based on physical and/or mathematical principles, in other, more advanced texts.) We shall then look at some important properties and conclusions that follow from this equation.

## 3.1 The Navier-Stokes equation

In any study of elementary partial differential equations, one of the three standard equations that are introduced is, usually, that of heat conduction (and the methods of separation variables and similarity solutions will also probably be discussed). This equation takes the form

$$\frac{\partial u}{\partial t} = k \frac{\partial^2 u}{\partial x^2} \text{ (in 1D) or, more generally, } u_t = k \nabla^2 u,$$

describing how heat diffuses through a material, where  $u$  is temperature and  $k$  is the thermal conductivity. Now consider a stationary fluid, which sits in a half space,  $y > 0$  say, bounded by a solid wall (interpreted as a flat plate here) on  $y = 0$  for  $-\infty < x < \infty$ ; the boundary (plate) is brought into motion, and this motion continues for all time, by moving it in the  $x$ -direction:

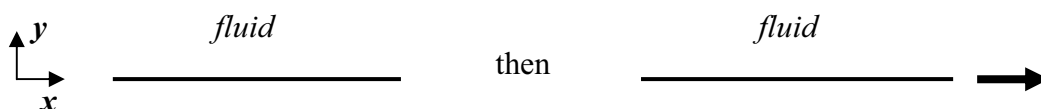

The fluid, being viscous, ‘sticks’ to the surface of this moving plate as it moves; the internal friction (viscosity) of the fluid then ensures that this effect diffuses in the  $y$ -direction through the fluid away from the plate. As time increases, more of the fluid is brought into motion; indeed, as time increases indefinitely, all the fluid will tend towards the motion of the plate. The diffusive process that brings this about, when viewed on the molecular level, is identical to the processes that are involved in the diffusion of heat: the molecules vibrate and interact (collide). On this basis, we can expect that the type of term in the governing equation, describing viscous action in a fluid on the macroscopic scale, should mimic that which appears in the equation of heat conduction i.e.

$$u_t = k \nabla^2 u \quad \text{would become} \quad \rho u_t = \mu \nabla^2 u.$$

temperature thermal conductivity	velocity component coefficient of friction
-------------------------------------	---

(In this simple statement, we have used the form equivalent to mass×acceleration = the force (friction).) Now, for our description of a fluid, we must incorporate this idea into Euler’s equation:

$$\mathbf{u}_t + (\mathbf{u} \cdot \nabla)\mathbf{u} = -\frac{1}{\rho} \nabla p + \mathbf{F},$$

which then becomes  $\mathbf{u}_t + (\mathbf{u} \cdot \nabla)\mathbf{u} = -\frac{1}{\rho} \nabla p + \mathbf{F} + \frac{\mu}{\rho} \nabla^2 \mathbf{u},$

where  $\mu$  is the *coefficient of Newtonian viscosity*, and we usually write  $\nu = \mu/\rho$ , the *kinematic viscosity*. (We shall consider  $\rho$  and  $\mu$  to be constants throughout the applications that we discuss here.) Our new equation of motion is the *Navier-Stokes equation*, developed by C.L.M.H. Navier (1785-1836) and G.G. Stokes (1819-1903), in the period 1823-1845, with some contributions from Poisson (1831) and very significant input from Saint-Venant (1843). More advanced texts should be consulted if a mathematically complete derivation is preferred. The first component of this equation, written in rectangular Cartesian coordinates, is

$$\frac{\partial u}{\partial t} + u \frac{\partial u}{\partial x} + v \frac{\partial u}{\partial y} + w \frac{\partial u}{\partial z} = -\frac{1}{\rho} \frac{\partial p}{\partial x} + \nu \left( \frac{\partial^2 u}{\partial x^2} + \frac{\partial^2 u}{\partial y^2} + \frac{\partial^2 u}{\partial z^2} \right) + F_1.$$

We should note that the higher order of this equation – now two, whereas Euler is one – requires an additional spatial boundary condition; this is the ‘no-slip’ condition at a solid boundary.

In this chapter, we will first construct a few simple, exact solutions of the Navier-Stokes (NS) equation (which are easily generated, and provide some tests for the relevance and accuracy of the equation). Then we will see how we can approximate the equation for the description of more complicated flows (which will be relevant to an important aspect of flow around wing sections).

### 3.2 Simple exact solutions

All these examples of simple, exact solutions of the NS equation can be treated as worked examples; they provide the basis for some of the exercises at the end of this chapter. We reiterate that, throughout our introductory studies here, we take both  $\rho$  and  $\mu$  to be constants; we will obtain the vorticity in each case, to show the rôle of viscosity in the generation of vorticity.

**(a) Plane Poiseuille flow** (Poiseuille 1840, 1841)

This is steady flow between two parallel, fixed planes; there is no body force and the motion is solely in the  $x$ -direction; the motion is maintained by a constant pressure gradient  $\partial p/\partial x = \alpha = \text{constant}$ . The motion is such that  $v = w = 0, u = u(y)$ :

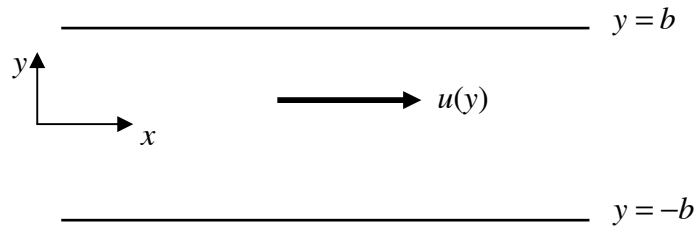

The Navier-Stokes equation then reduces to  $0 = -\frac{1}{\rho} \frac{\partial p}{\partial x} + \nu \frac{\partial^2 u}{\partial y^2}$  or  $u'' = \frac{\alpha}{\rho \nu} = \frac{\alpha}{\mu}$ ; thus

$$u(y) = \frac{1}{2} \frac{\alpha}{\mu} y^2 + Ay + B,$$

where  $A$  and  $B$  are the arbitrary constants of integration. The no-slip boundary conditions require  $u(b) = u(-b) = 0$ ; thus the solution is

$$u(y) = -\frac{\alpha}{2\mu} (b^2 - y^2).$$

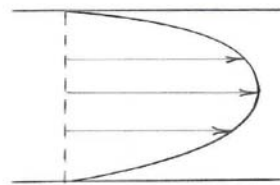

Note that  $u(y) \geq 0$  (where  $u$  is defined in the region between the plates) provided that  $\alpha < 0$  i.e. the pressure is higher to the left, and lower to the right, driving the flow from left to right (as common sense predicts). The figure shows a sketch of this *velocity profile*, which is parabolic here.

The vorticity for this flow field is  $\boldsymbol{\omega} = (0, 0, -u_y) = \left(0, 0, -\frac{\alpha}{\mu} y\right)$ , which is zero on the centre line, and a maximum at the walls (where the viscous action is strongest, by virtue of the no-slip boundary condition). Note that this solution does not exist if the viscosity is zero, because then the term which produces this profile ( $u_{yy}$ ) is absent from the equation.

**(b) Couette flow** (Couette, about 1890)

This is again steady flow between two parallel planes (although it is convenient to label them slightly differently here); one of the planes (the upper one, say) is moving at constant speed in the  $x$ -direction, and the other is fixed. There is no body force and no pressure gradients. The motion is described, exactly as before, with the velocity components given by  $v = w = 0, u = u(y)$ :

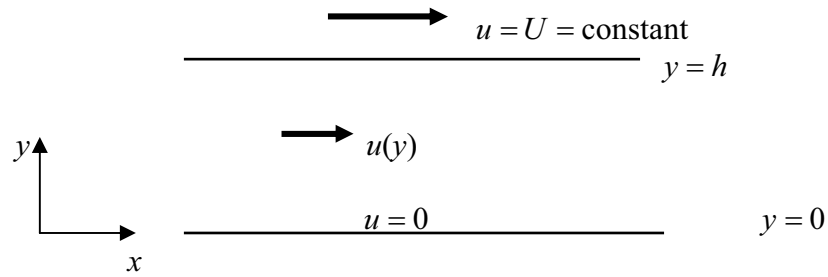

This time (cf. the previous example) we are left with simply  $0 = \nu u_{yy}$ , and so

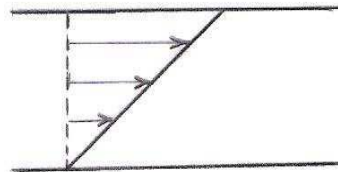

$$u(y) = Ay + B \text{ with } u(0) = 0 \text{ and } u(h) = U ;$$

We are experts in emulsifiers and stabilizers for:

- **bakery**
- **confectionery**
- **dairy**
- **ice cream**
- **margarine**
- **fine foods**

and we are constantly looking for new “heart-working” colleagues who are passionate and dedicated to helping food companies around the world develop new and innovating products.

**Emulsifiers and stabilizers**

Visit [www.palsgaard.com](http://www.palsgaard.com) to find out more about a career at Palsgaard HQ in Denmark or in one of our 11 subsidiaries around the world.

**Palsgaard®**  
 ♥ Heart working people

Palsgaard A/S  
 DK-7130 Juelsminde, Denmark  
 Phone +45 76 82 76 82  
 direct@palsgaard.dk



the solution is therefore the linear profile  $u(y) = U \frac{y}{h}$ .

The vorticity for this flow is  $\boldsymbol{\omega} = (0, 0, -U/h)$ , a constant independent of viscosity! This flow exists, therefore, as an inviscid, *rotational* flow.

**(c) Impulsively started plate** (Stokes' first problem, 1851)

The fluid exists in  $y > 0$ ,  $-\infty < x < \infty$ , bounded by the plane  $y = 0$  which starts impulsively from rest, instantaneously reaching a constant speed  $u = U$ . There are no body forces and no pressure gradients; the solution is described by

$$v = w = 0, u = u(y, t) \text{ with } u = \begin{cases} U \text{ on } y = 0 \\ \rightarrow 0 \text{ as } y \rightarrow \infty \end{cases} \text{ for all finite time.}$$

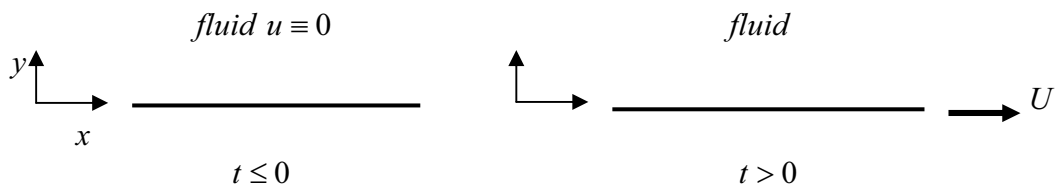

The NS equation now reduces to  $u_t = \nu u_{yy}$ , and the relevant solution takes a similarity form (cf. one of the classical solutions of the 1D heat conduction equation); thus we seek a solution

$$u(y, t) = f(yt^n) \text{ for some constant } n.$$

This then gives

$$nyt^{n-1} f'(\eta) = \nu t^{2n} f''(\eta) \text{ where } \eta = yt^n, \text{ or } nt^{-1} \eta f' = \nu t^{2n} f'';$$

so we choose, for  $t > 0$ ,  $n = -1/2$ :

$$f(\eta) = A \int \exp(-\eta^2/4\nu) d\eta.$$

The requirement that  $u$  (i.e.  $f$ )  $\rightarrow 0$  as  $y \rightarrow \infty$  for  $t > 0$  gives (for a relabelled  $A$ )

$$f(\eta) = A \int_{y/\sqrt{t}}^{\infty} \exp(-\eta^2/4\nu) d\eta,$$

and then  $u = U$  on  $y = 0$  for  $t > 0$  is satisfied if  $U = A \int_0^{\infty} \exp(-\eta^2/4\nu) d\eta$ . We introduce  $x = \eta/2\sqrt{\nu}$ , and use  $\int_0^{\infty} \exp(-x^2) dx = \frac{1}{2}\sqrt{\pi}$ , to write the solution as

$$u(y,t) = \frac{2U}{\sqrt{\pi}} \int_{y/2\sqrt{\nu t}}^{\infty} \exp(-x^2) dx.$$

For this flow, the vorticity takes a more complicated form:

$$\boldsymbol{\omega} = \left( 0, 0, \frac{U}{\sqrt{\pi\nu t}} \exp(-y^2/4\nu t) \right),$$

which shows how the vorticity changes in both space and time, decaying very rapidly away from the surface of the plate.

**(d) Oscillating flat plate** (Stokes' second problem 1851)

This is the same geometry as in (c), but now the plate, for all time, is oscillated according to

$$u \begin{cases} = U \cos \omega t \text{ on } y = 0 \text{ for all time} \\ \rightarrow 0 \text{ as } y \rightarrow \infty \end{cases}$$

where  $U$  and  $\omega$  are constants. The neatest way to solve this problem is to seek a solution in the form

$$u(y,t) = \Re \left( A e^{i\omega t + \lambda y} \right) \text{ (denoting the real part);}$$

it is sufficient simply to write  $u$  as this expression, without the addition of the real part, at this stage. (The equation, being linear, will give both the real and imaginary parts as zero, and then we use one of these, as appropriate.) Thus, from  $u_t = \nu u_{yy}$ , we obtain

$$i\omega = \nu \lambda^2 \text{ and so } \lambda = \pm \sqrt{\frac{\omega}{\nu}} \frac{1}{\sqrt{2}} (1+i);$$

but we must satisfy the condition that the flow be undisturbed at infinity, and so we select the minus sign here. Our solution is therefore

$$u(y,t) = \Re \left( A e^{i\omega t} e^{-\sqrt{\omega/2\nu}(1+i)y} \right) = A e^{-\sqrt{\omega/2\nu}y} \cos \left( \omega t - \sqrt{\frac{\omega}{2\nu}} y \right),$$

where, now,  $A$  is some real constant. The condition on  $y = 0$  yields, immediately,  $A = U$ ; the final solution is therefore

$$u(y,t) = Ue^{-ky} \cos(\omega t - ky) \text{ where } k = \sqrt{\omega/2\nu}.$$

This describes a disturbance that decays exponentially away from the oscillating plate, the disturbance propagating into  $y > 0$  as a wave with speed  $\omega/k = \sqrt{2\omega\nu}$ .

The vorticity for this flow is wave-like and decays away from the plate:

$$\boldsymbol{\omega} = (0, 0, Uk\{\cos(\omega t - ky) - \sin(\omega t - ky)\}e^{-ky}).$$

**(e) Flow through a pipe** (Hagen, 1839; Poiseuille, 1840)

This final example is the axi-symmetric version of (a), above. Thus we have steady flow along the pipe, in the absence of body forces, but with a constant pressure gradient in the  $z$ -direction:  $\frac{\partial p}{\partial z} = \alpha$ . The solution that we seek is then described by  $u = v = 0, w = w(r)$  (there is no dependence on  $\theta$ : axi-symmetric); from the NS equation (in cylindrical coordinates – see Appendix 2) we obtain

$$0 = -\frac{1}{\rho} \frac{\partial p}{\partial z} + \nu \left( \frac{d^2 w}{dr^2} + \frac{1}{r} \frac{dw}{dr} \right),$$

with the boundary condition  $w = 0$  on the inside wall of the pipe, say at  $r = a$ . (This is only one condition; the second arises by imposing boundedness of the function  $w$ , as we shall see.) Thus we obtain

$$(rw')' = \frac{\alpha}{\mu} r \text{ and so } rw' = \frac{1}{2} \frac{\alpha}{\mu} r^2 + A \text{ and then } w(r) = \frac{1}{4} \frac{\alpha}{\mu} r^2 + A \ln r + B.$$

But the solution is defined for  $0 \leq r \leq a$ , which requires the  $\ln r$  term to be absent – this is undefined on  $r = 0$  – and so we are left with

$$w(r) = \frac{1}{4} \frac{\alpha}{\mu} r^2 + B$$

which, with the boundary condition on  $r = a$ , gives

$$w(r) = -\frac{\alpha}{4\mu} (a^2 - r^2).$$

This profile is again parabolic, so in  $(r, z)$ -coordinates it is identical to the profile found in (a), which then produces a paraboloid-shaped profile for the axisymmetric flow down the pipe. We also note that the same condition on the pressure gradient applies, in order to drive the flow along the pipe in the sense of increasing  $z$ . The vorticity, in cylindrical coordinates  $(r, \theta, z)$ , is

$$\boldsymbol{\omega} = (0, -w'(r), 0) = (0, -\alpha r/2\mu, 0).$$

**Comment:** A useful exercise is to apply this velocity profile to the problem of flow through a pipe; see Example 8. In that calculation, we found that

$$\int_0^{R(z)} r w(r, z) dr = \text{constant}$$

and now we choose to use a profile  $w = \frac{U(z)}{R^2}(R^2 - r^2)$  for given  $R = R(z)$  (which describes how the radius of the pipe changes with distance along the pipe). This corresponds to the form used in Example 8, but now for a parabolic profile;  $U(z)$  is the maximum speed along the pipe, attained on the centre line. Integration then gives directly:

$$\frac{U}{R^2} \left[ \frac{1}{2} r^2 R^2 - \frac{1}{4} r^4 \right]_0^{R(z)} = \frac{1}{4} UR^2 = \text{constant},$$

which is simply (maximum speed)  $\times$  area = constant; cf. the earlier result.

**STUDY FOR YOUR MASTER'S DEGREE**  
**IN THE CRADLE OF SWEDISH ENGINEERING**

Chalmers University of Technology conducts research and education in engineering and natural sciences, architecture, technology-related mathematical sciences and nautical sciences. Behind all that Chalmers accomplishes, the aim persists for contributing to a sustainable future – both nationally and globally.

Visit us on **Chalmers.se** or **Next Stop Chalmers** on facebook.

**CHALMERS**  
UNIVERSITY OF TECHNOLOGY



### 3.3 The Reynolds number

In order to initiate this important investigation, and to introduce a fundamental idea and property of the Navier-Stokes equation, we make some very general observations about the possible *scales* (sizes) associated with various flows. We are given

$$\frac{D\mathbf{u}}{Dt} = \mathbf{u}_t + (\mathbf{u} \cdot \nabla)\mathbf{u} = -\frac{1}{\rho}\nabla p + \mathbf{F} + \nu\nabla^2\mathbf{u},$$

and we suppose that we are considering a general class of problems that are characterised by typical scales:

- a typical speed,  $U$ , of the flow past an object
- a typical dimension (size),  $d$ , of the object (normally measured in the direction of the flow).

We use these (constant) scales to define non-dimensional variables. That is, rather than use standard measurement scales – metres or centimetres, or miles per hour or the kilometres per second – we use the scales specifically associated with the problem. The resulting equations will then be equally applicable to an aircraft, a bird or swimming protozoa.

To proceed, we define new variables according to

$$\mathbf{x} = d\hat{\mathbf{x}}, \mathbf{u} = U\hat{\mathbf{u}}, t = \frac{d}{U}\hat{t}, p = \rho U^2 \hat{p},$$

where the combination  $d/U$  gives a typical time for the flow to go past the object, and the definition for  $p$  is based on the structure of Bernoulli's equation. The variables with the circumflex are now non-dimensional, with e.g.

$$\mathbf{u}(\mathbf{x}, t) = U\hat{\mathbf{u}}(\hat{\mathbf{x}}, \hat{t}) = U\hat{\mathbf{u}}\left(\frac{\mathbf{x}}{d}, \frac{U}{d}t\right).$$

The new non-dimensional variables are now used in the NS equation to give

$$\frac{U^2}{d} \frac{\partial \hat{\mathbf{u}}}{\partial \hat{t}} + \frac{U^2}{d} (\hat{\mathbf{u}} \cdot \hat{\nabla})\hat{\mathbf{u}} = -\frac{1}{\rho} \frac{\rho U^2}{d} \hat{\nabla} \hat{p} + \mathbf{F} + \nu \frac{U}{d^2} \hat{\nabla}^2 \hat{\mathbf{u}},$$

where  $\hat{\nabla}$  denotes the gradient operator expressed in the new variables. Rearranging this equation gives

$$\frac{D\hat{\mathbf{u}}}{D\hat{t}} = -\hat{\nabla} \hat{p} + \left(\frac{d}{U^2}\right) \mathbf{F} + \frac{\nu}{dU} \hat{\nabla}^2 \hat{\mathbf{u}},$$

where  $\left(\frac{d}{U^2} \mathbf{F}\right)$  is a non-dimensional version of the body force (which will not be important in our discussions, but if gravity were to be retained, for example, then this generates the *Froude number*). The important non-dimensional number for us is  $\nu/dU$ , which is usually written as

$$Re = \frac{dU}{\nu} = \frac{\rho U d}{\mu};$$

this is the *Reynolds number*, introduced by Reynolds in 1883. [Osborne Reynolds, 1842-1912, British engineer and physicist; gave the first analysis of turbulent flow; also made contributions to the study of vortex motions and the theory of propellers.]

This property of the equations – the appearance of the Reynolds number – is often called *dynamical similarity*: the equation and solutions do not depend on the individual values of  $U$ ,  $d$  and  $\nu$ , but on the combination exhibited by this number. Even if the values of these three constants are very different for very different flows, the flows are intrinsically the same if the value of  $R_e$  is the same: the flows are then dynamically similar. (Reynolds demonstrated that the value of  $R_e$  is the fundamental parameter that describes the transition from laminar to turbulent flow.)

For problems that are usually considered under the umbrella of fluid mechanics, there is a significant range of  $R_e$  values e.g.

- smallest swimming protozoa: approximately  $10^{-2}$
- blood flow in aorta: about  $10^3$
- large civil aircraft: about  $10^8$
- large ocean-going liner: about  $10^9$ .

For us, when we consider flow over the wing of an aircraft, we shall be working with very large Reynolds numbers – typically about  $10^8$ . With this number written in the NS equation, and in the absence of the body force term (which is unimportant for the flow over a wing, as we explain later), we obtain

$$\frac{D\mathbf{u}}{Dt} = -\nabla p + \frac{1}{R_e} \nabla^2 \mathbf{u},$$

and we have taken the opportunity to dispense with the circumflex: all variables hereafter will be non-dimensional. (This last manoeuvre is simply to make it easier to write the equations and variables.) We now see that, for very large  $R_e$ , there is a great temptation – at least in order to generate a suitable approximate solution – to neglect the viscous terms. If this is a reasonable manoeuvre, then it is good news: we will have reverted to the Euler equation, which is far simpler to work with than the Navier-Stokes equation. However, if we do use this model, then the no-slip boundary condition can *never* be imposed – yet this is a property of any flow of a physically realistic fluid. How is this paradox overcome?

We shall describe the essential features of this type of problem in fluid mechanics. We find that the viscous contribution – and so the importance of the viscous terms in the equation – is relevant only very close to a solid boundary. Away from this boundary, the flow is very accurately described by an inviscid (Euler) theory. (In the context of aerofoil theory, this means that there is a very thin layer, over the surface of the wing, where the rôle of viscosity is important, but then a small distance away from the surface of the wing, inviscid theory is sufficiently accurate.)

The mathematical (and physical) idea that is at the heart of this approach is the concept of a ‘boundary layer’. This has important consequences for our current problem in fluid mechanics, but it also provides the basis for a related analysis of a large class of differential equations.

### 3.4 The (2D) boundary-layer equations

We now provide a discussion of the important work developed by Prandtl (and published in 1904) which explains the mathematical difficulty and how to overcome it. [Ludwig Prandtl, 1875-1953, German applied mathematician who was trained in solid mechanics; nowadays, he is regarded as the ‘father of modern fluid mechanics’; introduced the notion of a boundary layer and also developed the ‘lifting line’ theory for aerofoils.] First, we comment that the body force – gravity – is unimportant in these flows: the variation of pressure, due to gravity, over the vertical dimension of a wing (not more than a metre or so), is altogether negligible. We shall therefore ignore the body force hereafter. Thus in two dimensions, and written in non-dimensional variables, we have the set of governing equations

$$u_t + uu_x + vu_y = -p_x + R_e^{-1}(u_{xx} + u_{yy});$$

$$v_t + uv_x + vv_y = -p_y + R_e^{-1}(v_{xx} + v_{yy});$$

$$u_x + v_y = 0.$$



**Stafford**  
associates

**Find your next education here!**

**Click here**

[bookboon.com/blog/subsites/stafford](http://bookboon.com/blog/subsites/stafford)

We now consider the simplest problem that exhibits the difficulties that we want to explore: steady, uniform flow over a flat plate. (It is straightforward, although slightly more involved, to extend this approach to the problem over a general curved surface; we shall comment on this later.) So we have



and we remember that the choice of non-dimensional variables means that the speed of the flow past the plate is unity in this system. If we ignore the viscous terms i.e. take the limit  $R_e \rightarrow \infty$  in the NS equation, then the exact solution is simply

$$u = 1, \quad v = 0, \quad p = \text{constant},$$

and the constant pressure is the background, ambient pressure (prescribed at infinity, say). Of course, this solution does not satisfy the no-slip boundary condition on the surface of the plate. (For simplicity, we shall discuss only the fluid above and on the upper surface of the plate; we could consider a corresponding calculation for the lower-half plane and the under-surface of the plate. Consistent with this interpretation of the problem, we shall ignore the existence of a front edge to the plate; this is certainly absent if we regard the plate as *infinitesimally thin*. The analysis that we describe here, based on scalings, can be extended to allow for a plate of non-zero thickness and a suitable neighbourhood at the front of the plate – and also a corresponding description for the flow that leaves the rear of a finite plate.)

Prandtl realised that, for large  $R_e$ , both physically and as a property of the differential equations, there is a ‘thin’ layer on the surface of the plate, where the viscous contribution, and the relevant terms, are important. For the equations valid in this thin layer, the correct, no-slip boundary condition can then be imposed. For this to be possible, the term  $R_e^{-1} u_{yy}$  must be retained (and of the same size as other, appropriate, terms in the equations, so that a balance exists even for  $R_e \rightarrow \infty$ ). This is accomplished by introducing a *scaled variable*:

$$y = \frac{1}{\sqrt{R_e}} Y,$$

so that, for example, we now treat  $u = u(x, Y, t) = u(x, y\sqrt{R_e}, t)$ . (It is fairly routine, and more general, to assume that some scaling exists, based on a general power of  $R_e$ , and to seek it; in this introductory discussion, we shall simply use the form that is appropriate for this problem.) The interpretation of the scaling is that, for any reasonable value of  $Y$  – we normally express this as  $O(1)$  – then, as  $R_e \rightarrow \infty$ , we have that the (essentially physical)  $y$  as very small (and so we have a ‘thin layer’ on the plate).

To proceed, we make the following observation. The equation of mass conservation, as we know (see §2.6), implies the existence of a stream function; let us write

$$u = \psi_y, \quad v = -\psi_x,$$

and then the scaling on  $y$  gives  $u = \sqrt{R_e} \psi_Y$ . However,  $u$  cannot possibly be large, because we know that the speed of the flow away from the plate is 1, and it should be zero on the surface of the plate (so we expect a solution  $u \in [0, 1]$ ). This difficulty is easily overcome by redefining – scaling –  $\psi$  according to  $\psi = \frac{1}{\sqrt{R_e}} \Psi$ , which then implies that we must scale  $v$ :  $v = \frac{1}{\sqrt{R_e}} V$ . A small  $v$  is to be expected because, on the surface of the plate, we have  $v = 0$  and it is, therefore, nearly zero very close to the plate i.e. when described in terms of  $Y$ . Note, however, that  $v$  is not governed by the viscosity of the fluid;  $v = 0$  is simply a no-flow-through-a-solid-boundary condition. Also observe that there is no scaling associated with  $x$  (at least, away from the front edge of the plate, and with no end to the plate i.e. it is semi-infinite); the important variation is away from the plate, in the  $y$ -direction. Thus we scale the original (non-dimensional) equations according to

$$y = \frac{1}{\sqrt{R_e}} Y, \quad v = \frac{1}{\sqrt{R_e}} V,$$

and hereafter treat  $u$ ,  $V$  and  $p$  as functions of  $x$ ,  $Y$  and  $t$ . Thus we obtain

$$u_t + uu_x + \frac{1}{\sqrt{R_e}} V \sqrt{R_e} u_Y = -p_x + R_e^{-1} u_{xx} + R_e^{-1} (\sqrt{R_e})^2 u_{YY};$$

$$\frac{1}{\sqrt{R_e}} V_t + \frac{1}{\sqrt{R_e}} u V_x + \left( \frac{1}{\sqrt{R_e}} \right)^2 \sqrt{R_e} V V_Y = -\sqrt{R_e} p_Y + R_e^{-1} \frac{1}{\sqrt{R_e}} V_{xx} + R_e^{-1} \frac{1}{\sqrt{R_e}} (\sqrt{R_e})^2 V_{YY}$$

$$\text{and } u_x + \frac{1}{\sqrt{R_e}} \sqrt{R_e} V_Y = 0.$$

These simplify to give

$$u_t + uu_x + V u_Y = -p_x + R_e^{-1} u_{xx} + u_{YY};$$

$$\frac{1}{R_e} (V_t + u V_x + V V_Y) = -p_Y + \frac{1}{R_e^2} V_{xx} + \frac{1}{R_e} V_{YY},$$

$$\text{and } u_x + V_Y = 0.$$

In these equations, we now take the limit  $R_e \rightarrow \infty$ ; this procedure generates a reduced set of equations, being the first approximation valid in this thin layer:

$$u_t + uu_x + V u_Y = -p_x + u_{YY}; \quad p_Y = 0; \quad u_x + V_Y = 0.$$

We observe that the dominant viscous term,  $u_{YY}$ , now appears as an  $O(1)$  term, balanced by other  $O(1)$  terms in the first equation; also note that the pressure is independent of  $Y$  in this region.

These are the *Prandtl boundary-layer equations*, valid in a thin layer close to the surface of the plate; this layer, quite naturally, is called the *boundary layer*. These constitute a first approximation, appropriate to the boundary layer, valid for  $Re \rightarrow \infty$ ; correspondingly, outside the boundary layer, the first approximation is simply the equations based on Euler:

$$u_t + uu_x + vv_y = -p_x; v_t + uv_x + vv_y = -p_y; u_x + v_y = 0.$$

**Comment:** It is important to appreciate that the demarcation between the boundary layer and the outer flow is not provided by a well-defined line. Rather, the solution of the boundary-layer problem merges into the solution of the outer-flow problem as  $Y \rightarrow \infty$ ; correspondingly, the solution to the outer-flow problem merges into that in the boundary layer as  $y \rightarrow 0$ . Since WWII, there has been a vast amount of analytical work done on many aspects of boundary-layer theory, to the extent that we know a lot about the higher-order corrections to this basic solution-structure, and in many different scenarios. These include the behaviour in the region where the boundary layer leaves the plate (and becomes a wake), and the prediction of boundary-layer separation.



**STUDY.**  
The stuff you'll need to make a good living

**PLAY.**  
The stuff that makes life worth living



**NORWAY.**  
**YOUR IDEAL STUDY DESTINATION.**

**WWW.STUDYINNORWAY.NO**  
**FACEBOOK.COM/STUDYINNORWAY**





The leading-order approximation, for  $R_e \rightarrow \infty$ , for both the boundary-layer and outer flows, is appropriate for *any curved* plate (although the higher-order correction terms are different, for various shapes of plate). That is, the presentation given above holds for any plate, provided that  $x$  is measured along the plate, and  $y$  is always at right angles to it:

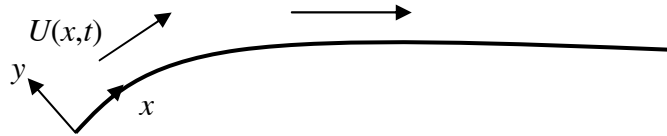

Now let us suppose that the flow, away from the plate, is described by  $u = U(x, t)$ ; thus the problem for the boundary-layer equations must satisfy the boundary conditions:

$$u \rightarrow U(x, t) \text{ as } Y \rightarrow \infty; u = V = 0 \text{ on } Y = 0 \text{ in } x > 0.$$

(Note that the front edge of the plate is excluded here:  $x \neq 0$ .)

Now we evaluate the first Prandtl equation (which, we see, is a version of the component of NS in the  $x$ -direction) as  $Y \rightarrow \infty$  to give

$$p_x \rightarrow -(U_t + UU_x).$$

But the Prandtl equations include the condition:  $p_Y = 0$ , so the pressure does not vary across the boundary layer; thus  $p_x = -(U_t + UU_x)$  *throughout* the boundary layer. The full boundary-layer problem can therefore be written

$$u_t + uu_x + Vu_y = U_t + UU_x + u_{YY}; u_x + V_Y = 0,$$

with  $u \rightarrow U(x, t)$  as  $Y \rightarrow \infty$ ;  $u = V = 0$  on  $Y = 0$  (all in  $x > 0$ ).

Note that any unsteadiness in the boundary layer will be driven, in this model, by any time dependence on the flow in the region away from the plate i.e. as given by  $U(x, t)$ . Consequently, a steady boundary layer is associated with  $U = U(x)$ .

### 3.5 The flat-plate boundary layer

We complete the discussion (as relevant to this introduction to these ideas) by examining the details for the constant-speed, steady-flow over a semi-infinite flat plate:

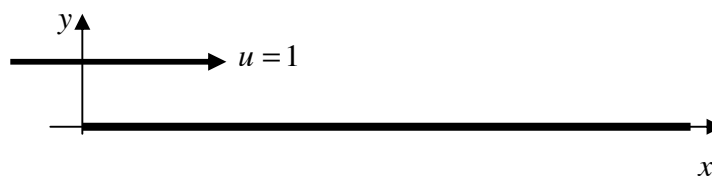

The problem for this specific geometry is then

$$uu_x + Vu_Y = u_{YY}; u_x + V_Y = 0,$$

with  $u \rightarrow 1$  as  $Y \rightarrow \infty$  ( $x > 0$ );  $u = V = 0$  on  $Y = 0$  in  $x > 0$ .

An exact solution was found by Blasius (in 1908) by constructing a similarity solution for the stream function. So first we write  $u = \Psi_Y$ ,  $V = -\Psi_x$  (which therefore ensures that the equation of mass conservation is satisfied), which gives

$$\Psi_Y \Psi_{xY} - \Psi_x \Psi_{YY} = \Psi_{YYY}.$$

We seek a solution in the form  $\Psi(x, Y) = \sqrt{x} f(\eta)$  where  $\eta = Y/2\sqrt{x}$  (and the 2 is merely an algebraic convenience); this solution has the property that any scale length cancels: there is no scale length for a semi-infinite plate! (It was this observation that prompted Blasius to write the solution in this form.) It is clear that this solution is valid only on the plate, because we must use  $x > 0$ .

Thus we have  $\Psi_Y = \frac{1}{2} f'$  and  $\Psi_x = \frac{1}{2} f / \sqrt{x} - \frac{1}{4} Y f' / x$ , which leads to the equation for  $f$ :

$$\frac{1}{2} f' \left[ \frac{1}{4} \frac{f'}{x} - \frac{1}{4} \frac{f'}{x} - \frac{1}{8} \frac{Y}{x\sqrt{x}} f'' \right] - \left[ \frac{1}{2} \frac{f}{\sqrt{x}} - \frac{1}{4} \frac{Y}{x} f' \right] \frac{1}{4} \frac{f''}{\sqrt{x}} = \frac{1}{8} \frac{f'''}{x}.$$

This simplifies, in  $x > 0$ , to give

$$f''' + ff'' = 0;$$

the boundary conditions are:

$$u = 0 \text{ on } Y = 0 \text{ (} x > 0 \text{) so } f'(0) = 0;$$

$$V = 0 \text{ on } Y = 0 \text{ (} x > 0 \text{) so } f(0) = 0;$$

$$u \rightarrow 1 \text{ as } Y \rightarrow \infty \text{ (} x > 0 \text{) so } f' \rightarrow 2 \text{ as } \eta \rightarrow \infty.$$

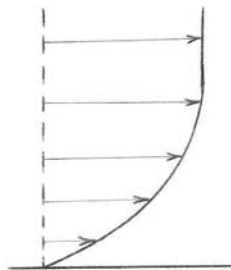

Sadly, this problem cannot be solved analytically, but a numerical solution is quite easily computed; a typical velocity profile through the boundary layer (for steady, laminar flow) is shown in the figure. We also provide an indication, based on experimental data, of just how accurate this theory is for reproducing the behaviour of the flow in the laminar boundary-layer on a flat plate. The solid line is the obtained from the (numerical) solution of the equation for  $f(\eta)$ , and the points (dots) are experimental results (based on the work of Nikuradse) for various Reynolds number.

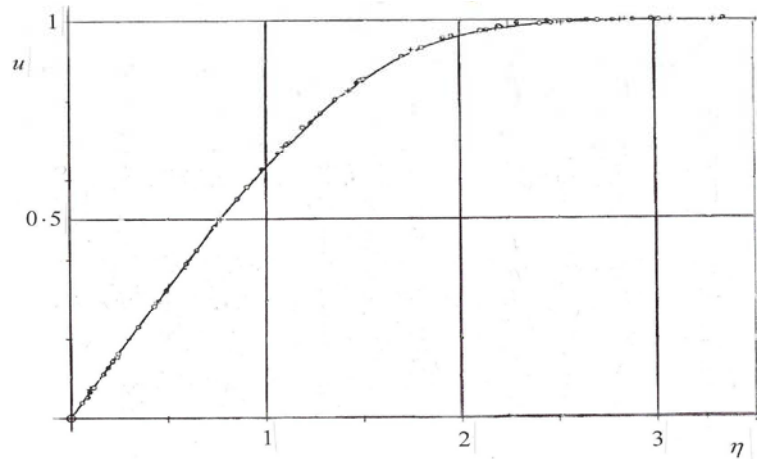

## Free online Magazines



Click here to download   
[SpeakMagazines.com](http://SpeakMagazines.com)



## Exercises 3

60. *Simple viscous flow I.* See §3.2 (a) & (b); consider the flow  $u = u(y)$ ,  $v = w = 0$ , between two infinite planes ( $y = 0$ ,  $y = h > 0$ ). The plane  $y = 0$  is stationary and the other is moving at the constant speed  $u = u_0$ ; there is, in addition, a constant pressure gradient,  $\partial p / \partial x = \alpha$  and no body forces. Determine  $u(y)$ .
61. *Simple viscous flow II.* See §3.2 (a); consider the flow between two stationary, infinite planes ( $y = 0$ ,  $y = h > 0$ ) in the presence of the constant pressure gradient  $\partial p / \partial x = \lambda$ , but with the additional requirement that  $\partial p / \partial y = -\rho g$  (= constant), being the only body force present. Find both  $u(y)$  and  $p(x, y)$ , given that  $p = p_0 = \text{constant}$  on  $x = y = 0$ .
62. *Cross flow.* See Ex. 60 and §3.2 (b); the flow is between the two planes, one of which is stationary and the other moving (all according to Ex. 60); there is no pressure gradient and no body forces. In this case there is a constant cross-flow:  $v = -V_0$  (= constant). Find  $u(y)$ . [This is possible if the two planes are porous.]
63. *Suction.* An incompressible, viscous fluid occupies the region  $y > 0$  on one side of an infinite flat plate  $y = 0$ . The plate is moving at the speed  $u = u_0(t)$  in the  $x$ -direction, and fluid is being sucked through the plate with a constant speed  $v = -V$ ; there is no variation in the  $x$ -direction, no body forces, no pressure gradients and no motion at infinity i.e.  $u \rightarrow 0$  as  $y \rightarrow \infty$ . Show that the Navier-Stokes equation implies

$$u_t - V u_y = \nu u_{yy}.$$

Find appropriate solutions for  $u(y, t)$  in the cases: (a)  $u_0 = 1$ ; (b)  $u_0 = e^{\alpha t}$  ( $\alpha > 0$  constant).

64. *Axisymmetric axial Couette flow.* Cf. §3.2 (e); consider axisymmetric flow of a viscous fluid, in the absence of any pressure gradients or body forces, between two concentric circular cylinders. The outer cylinder,  $r = R$ , is fixed, and the inner one,  $r = \lambda R$  ( $0 < \lambda < 1$ ), is moving in the axial direction with a constant speed  $w = w_0$ ; find  $w(r)$ .
65. *Vertical cylinders.* Co-axial circular cylinders, of radii  $a$  and  $b$  ( $b > a$ ) are placed with their axis vertical; an incompressible, viscous fluid occupies the annular region between them. The outer cylinder is fixed, and the inner one is constrained to move vertically downwards with the constant speed  $w_0$ . Seek a solution which describes steady motion under (constant) gravity, with pressure constant everywhere in the fluid and all streamlines parallel to the axis of the cylinders, and hence show that the speed downwards,  $w(r)$  satisfies

$$w_{rr} + r^{-1} w_r - g/\nu = 0.$$

Hence find the relevant solution for  $w(r)$ .

66. *Two rotating cylinders.* An incompressible, viscous fluid is circulating between two infinitely long cylinders; the outer one (which is hollow) is of radius  $a$  and is rotating about its axis with an angular speed  $\omega$ . The other cylinder, which has the same axis as the first, is of radius  $\frac{1}{2}a$  and is rotating at the angular speed  $-2\omega$ . Show that the fluid is at rest at a distance  $a/\sqrt{2}$  from the axis of the cylinders. Also find the pressure difference in the fluid at the two surfaces of the cylinders.

67. *Vorticity I.* Sketch the vorticity for the flows discussed in §3.2 (c) and (d), and, for each, this could be in  $y$  at fixed  $t$ , and then in  $t$  at fixed  $y$ .

68. *Vorticity II.* Find the vorticity for each of the flows found in Ex. 60, 61, 62, 63, 64.

69. *Suction.* In a conventional boundary layer, show that a solution of Prandtl's equation in a region where the variation in  $x$  is small (i.e. assume that the derivatives with respect to  $x$  are zero) is

$$V = -V_0 = \text{constant}; \quad u(Y) = u_0(1 - e^{-V_0 Y}),$$

where  $u \rightarrow u_0$  (constant) as  $Y \rightarrow \infty$ . (This is a special case of boundary-layer control, by using suction; this solution is usually called the 'asymptotic suction profile'.) Now show that this solution is an *exact* solution of the full Navier-Stokes and mass conservation equations, in the absence of body forces and for constant pressure.

70. *Boundary-layer growth.* A viscous fluid (of constant speed  $u = U_0$  at infinity) flows steadily over a flat,  $y = 0$ ,  $x \geq 0$ ; write down Prandtl's boundary-layer equations for this problem (see §3.4). Let the thickness of the boundary layer be represented by  $h(x)$  (so that  $u = U_0$  and  $u_Y = 0$  on  $Y = h(x)$ ); show that

$$\frac{d}{dx} \int_0^{h(x)} (u - U_0)u \, dY = -\left(\frac{\partial u}{\partial Y}\right)_{Y=0}.$$

Suppose that  $u = U_0 \sin\left(\frac{\pi Y}{2h}\right)$ ,  $0 \leq Y \leq h$ , is a reasonable approximation for a boundary-layer flow, and hence find  $h(x)$ .

71. *Blasius equation.* Given the Blasius problem for  $f(\eta)$ :

$$f f'' + f''' = 0 \quad \text{with} \quad f(0) = f'(0) = 0, \quad f' \rightarrow 2 \quad \text{as} \quad \eta \rightarrow \infty$$

(where  $\eta = Y/2\sqrt{x}$  and  $\psi = \sqrt{x}f(\eta)$ ), consider the following.

(a) This problem possesses a *group* property; to see this, transform  $f \rightarrow \lambda f$ ,  $\eta \rightarrow \eta/\lambda$  (where  $\lambda$  is a non-zero arbitrary parameter). What is the new problem? How might this be useful in a numerical solution of the problem which 'shoots' from some initial conditions?

(b) Show that the order of the equation can be reduced by introducing  $f' = g(f)$ .

(c) Show that the solution  $f = 2\eta - a + F(\eta)$  ( $a$  constant, which can be found only from a numerical solution), with  $\eta \rightarrow \infty$ , is consistent with the Blasius equation. Find the equation for  $F$  and, under the assumption that  $F$  (and  $F'$ ) approach zero as  $\eta \rightarrow \infty$ , approximate the equation for  $F$  and then integrate it, to show that

$$F' \approx A \int_{\eta}^{\infty} \exp(-y^2) dy \quad (A \text{ is an arbitrary constant}).$$

- (d) Show that the solution  $f \approx B\eta^2 + C\eta^5$ , for  $\eta \rightarrow 0$ , is consistent with the Blasius equation for a particular relation between the constants  $B$  and  $C$ ; find this relation.

72. *Boundary layer generated by a sink.* A sink is located at  $x = y = 0$ , generating the flow  $U(x) = -m/x$  ( $m > 0$  constant) outside the boundary layer (which exists on  $y = 0$  in  $x > 0$ ).

- (a) Show that Prandtl's boundary-layer equation can be written as

$$uu_x + Vu_y = -m^2/x^3 + u_{yy}.$$

- (b) Seek a solution in the form  $u = -\frac{m}{x}f(\eta)$ ,  $V = -\frac{mY}{x^2}f(\eta)$  where  $\eta = \frac{Y\sqrt{m}}{x}$ ; confirm that the equation of mass conservation is satisfied and, from the equation obtained in (a), that

$$f'' - f^2 + 1 = 0.$$

State the boundary conditions that  $f$  must satisfy.

- (c) Show that the relevant solution is  $f(\eta) = 1 - 3\operatorname{sech}^2[(\eta + a)/\sqrt{2}]$ , where  $a$  is the (positive) solution of  $\cosh(a/\sqrt{2}) = \sqrt{3}$ .

I joined MITAS because  
I wanted **real responsibility**

The Graduate Programme  
for Engineers and Geoscientists  
**Maersk.com/Mitas**





**Month 16**  
I was a construction  
supervisor in  
the North Sea  
advising and  
helping foremen  
solve problems

Real work  
International opportunities  
Three work placements







73. *Boundary layer with variable suction.* The Prandtl boundary-layer equations can be used to describe the flow in a boundary layer for which the exterior flow is  $u \rightarrow U(x) = x^m$  (as  $Y \rightarrow \infty$ ) and for which there is suction  $V(x) = -V_0 x^{(m-1)/2}$  on  $Y = 0$  in  $x > 0$  (where  $V_0$  is a positive constant).

(a) Show that Prandtl's boundary-layer equation can be written as

$$uu_x + Vu_y = mx^{2m-1} + u_{yy}.$$

(b) Seek a solution for which the stream function takes the form

$$\psi = x^{(m+1)/2} f(\eta) \text{ where } \eta = Yx^{(m-1)/2},$$

and hence show that  $f(\eta)$  satisfies

$$f''' + \frac{1}{2}(m+1)ff'' + m(1-f'^2) = 0.$$

State the boundary conditions that  $f$  must satisfy.

(c) In the case  $m = -1/3$ , integrate the equation for  $f(\eta)$  to obtain

$$f' + \frac{1}{6}f^2 = \frac{1}{6}\eta^2 + A\eta + B,$$

where  $A$  and  $B$  are arbitrary constants. Now show that the substitution  $f = 6\phi'/\phi$  reduces the equation to a linear, second order equation for  $\phi$ .

\*\*\*\*\*

# 4 Two dimensional, incompressible, irrotational flow

We now return to our earlier theme, based on the Euler equation; however, we shall make clear, particularly in the context of aerofoil theory, the rôle of viscosity. There are many aspects of fluid mechanics that can be studied e.g. boundary-layer theory, stability of flows, turbulent flow, gas dynamics and shock waves, vortex dynamics, statistical mechanics, and much more. We choose to follow the route that develops the application of complex-variable theory leading to classical (two dimensional) aerofoil theory. It will become clear that the methods that we present result in very powerful techniques for the construction, in general, of models for fluid flows. Although there are many ideas that we shall touch upon, our main aim is to lay the foundations for the theory of aerofoils and then to describe the ideas that underpin the generation of lift.

## 4.1 Laplace's equation

In this brief discussion of a simple problem involving a fluid flow, we show how standard and familiar methods might be used – and then explain why such methods are not likely to be useful for more realistic flows. Let us suppose that we have a 2D flow which is incompressible and irrotational, then a velocity potential exists which satisfies Laplace's equation:

$$\nabla^2 \phi = 0 \quad \text{or} \quad \phi_{xx} + \phi_{yy} = 0 \quad \text{with} \quad \mathbf{u} = (\phi_x, \phi_y).$$

For simple geometry, and a simple flow configuration, elementary methods for the solution of partial differential equations can be employed; to see what can be done, consider this example.

### Example 20

*Laplace's equation.* A (2D) box,  $0 \leq x \leq a$ ,  $0 \leq y \leq 2b$ , has three solid walls along  $x = 0$ ,  $y = 0$ ,  $y = 2b$ ; it is open on  $x = a$  ( $0 \leq y \leq 2b$ ) where fluid flows in and out, symmetrically about  $y = b$ . Find  $\phi(x, y)$  for this flow field, given  $\phi_x = u(y)$  across the opening.

---

The geometry here is

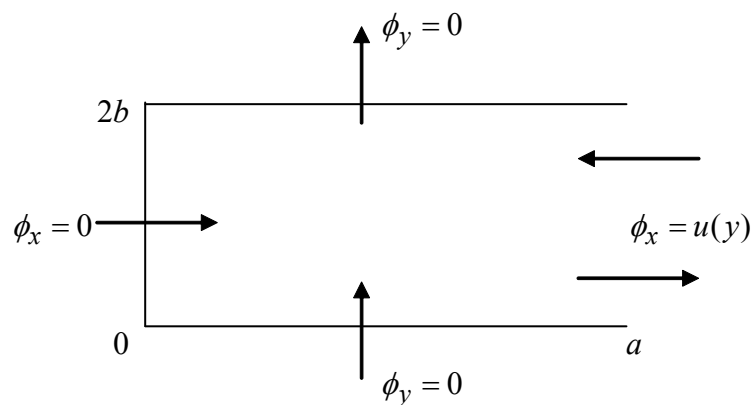

We seek a solution in the familiar form: separation of variables i.e.

$$\phi(x, y) = X(x)Y(y) \text{ and so } X''Y + XY'' = 0.$$

We set  $Y'' + \lambda^2 Y = 0$  (and then  $X'' - \lambda^2 X = 0$ ), with the boundary conditions

$Y'(0) = Y'(2b) = 0$ ; this is a standard eigenvalue problem, the solution of which is routine (eventually leading to the need for a Fourier representation of  $u(y)$ ).

This example shows that, in principle, such problems can be solved, but only if the geometry is particularly simple. What if the shape is more general – perhaps the shape of a section through a wing? We need a better way of tackling these problems. This, as we shall see, leads to a very powerful technique that enables quite accurate and sophisticated models of flows to be constructed.

## 4.2 The complex potential

From §2.6 (which describes two dimensional, incompressible, irrotational flow), we have

$$u = \phi_x = \psi_y \quad \text{and} \quad v = \phi_y = -\psi_x,$$

which are the Cauchy-Riemann relations for the two functions  $\phi$  and  $\psi$ . These conditions guarantee that the function  $\phi + i\psi$  is a differentiable function of the single complex variable  $Z = x + iy$  i.e.

$$\phi(x, y) + i\psi(x, y) = w(Z) = w(x + iy) \quad \text{and} \quad w'(Z) \text{ exists.}$$

(We choose to use upper-case  $z$  here because, sometimes, we use  $z$  as one of the variables in the definition of the complex variable e.g. a problem involving the vertical coordinate (rather than  $y$ ) and  $x$  would give rise to  $Z = x + iz$ . Although this possibility is not likely to be encountered in our work here, it is wise to become familiar with this slight change of notation.)

**Comment:** All of the ideas and techniques work for unsteady flow, so we could allow  $w(Z, t)$ , enabling some quite complicated problems in unsteady flow can be handled; we shall, in our discussions here, restrict ourselves to steady flows.

## Need help with your dissertation?

Get in-depth feedback & advice from experts in your topic area. Find out what you can do to improve the quality of your dissertation!

Get Help Now



Go to [www.helpmyassignment.co.uk](http://www.helpmyassignment.co.uk) for more info



The function  $w$  is called the *complex potential*. From it we may obtain both the velocity potential and the stream function but, in practice, it is more usual and helpful to extract the stream function (because this not only generates the velocity field – as does the velocity potential – but it also gives the streamlines). An important property of  $w$  follows immediately: take the partial  $x$ -derivative of the definition (or the  $y$ -derivative – it gives the same result; you should check this) to give

$$\frac{\partial}{\partial x}(\phi + i\psi) = \phi_x + i\psi_x = \frac{\partial w}{\partial x} = \frac{dw}{dZ} \frac{\partial Z}{\partial x} = w'(Z).$$

But we have  $\phi_x + i\psi_x = u - iv$ , and so

$$w'(Z) = u - iv:$$

the *complex velocity*. Thus the conventional derivative of the complex function  $w$  enables the velocity components to be obtained directly. (Do take note of the negative sign here; it is one of the common errors to work with  $w'(Z) = u + iv$ !)

The representation of  $w'(Z)$  as the complex velocity leads to two different ways of discussing, describing and constructing flow fields; in our presentation of these ideas, we shall make use of both. The two approaches are

- given a flow field, identify  $\mathbf{u}$  and hence obtain  $w(Z)$
- introduce (invent) any  $w(Z)$ , find  $\psi$  and then describe the flow field.

Although the more natural approach is likely to be the former, the latter can be used simply by combining some elementary functions (that represent some simple flows) and so invent more complicated flow fields.

### 4.3 Simple (steady) two-dimensional flows

We construct some simple flows, represented by suitable complex potentials, using – as appropriate – either one or other of the approaches mentioned above. Each one of these simple flows should be regarded as a ‘building block’; individually, they are not very interesting or important, but in combination they provide the basis for the construction of more complicated and realistic flows.

**(a) Uniform stream (or flow)**

Consider a flow which is a constant speed ( $U$ ), in a fixed direction (given by the angle,  $\alpha$ , relative to the positive  $x$ -axis); the flow exists throughout the plane:

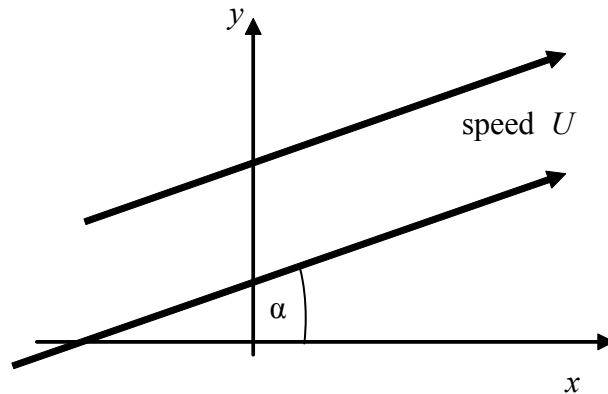

Thus we have  $\mathbf{u} = (U \cos \alpha, U \sin \alpha)$ , and so

$$\frac{dw}{dZ} = u - iv = U \cos \alpha - iU \sin \alpha = Ue^{-i\alpha};$$

this gives immediately that

$$w(Z) = Ue^{-i\alpha} Z,$$

and the constant of integration is altogether irrelevant. (The real part of the constant contributes to  $\phi$ , which defines, *via* derivatives, the velocity components; correspondingly, the imaginary part of such a constant merely adds a constant to  $\psi$  – and  $\psi = \text{constant}$  is the definition of the stream lines.)

This is our first *complex potential*. Thus, for example, given any  $w(Z) = AZ$ , we can interpret the complex constant to define a flow field:  $|A| (= U)$  is the speed of the flow throughout the plane, and  $-\arg(A) (= \alpha)$  gives its direction (and note the sign here).

**(b) A source (or sink) [sometimes called a 'line' source/sink]**

This flow field, in particular, is rarely used in isolation, but it will eventually be important. This represents a flow which, in the 2D plane, issues out from (or disappears into) a point in the plane; at this point there is a singularity! This means that, taking the whole plane, mass is not conserved – although it *is* conserved *everywhere except at* the singularity. This indicates that, if this flow field is to be useful, then the singularity must not appear in the flow field; this apparent paradox can be overcome (as we shall see) and practical use made of this 'model' flow field.

Consider a purely radial flow outwards/inwards from the origin; we will, later, allow this point of creation/destruction to be at any point in the plane:

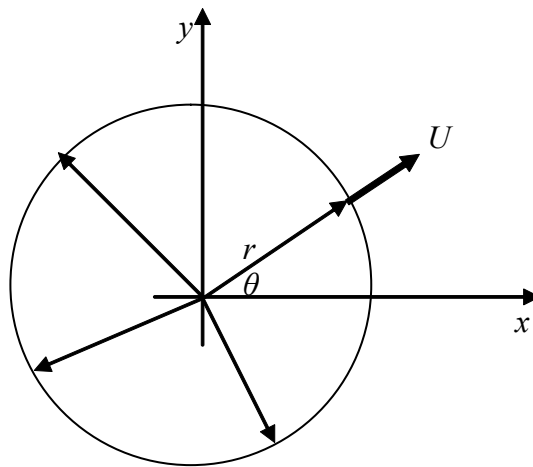

Let the speed at a radius  $r$  be  $U$  (and we have drawn here the case of a source: the flow is outwards); we define this flow to be such that the mass flow rate (out) is a constant:

$$2\pi rU = m = \text{constant} .$$

(Think of flow crossing the surface of a circular cylinder:  $(2\pi r \times 1) \times U$ , i.e. per unit length of the cylinder, together with the area  $\times$  speed rule; see Example 8.) But  $u = U \cos \theta$  and  $v = U \sin \theta$ , and so we get

$$\frac{dw}{dZ} = u - iv = U \cos \theta - iU \sin \theta = Ue^{-i\theta} .$$

$$\text{Thus } \frac{dw}{dZ} = Ue^{-i\theta} = \frac{m}{2\pi r} e^{-i\theta} = \frac{m}{2\pi} \frac{1}{re^{-i\theta}} = \frac{m}{2\pi} \frac{1}{Z} ,$$

$$\text{which gives } w(Z) = \frac{m}{2\pi} \log Z .$$

Again, we ignore the constant of integration (for the same reason as before). Note that we have written 'log' here; we could write 'Log', but that simply changes the additive constant, which we have just ignored.

The *strength* is  $m$ ; for  $m > 0$ , we have a source, and for  $m < 0$  a sink: the flow is inwards towards the origin. (The terminology 'line' refers to an imaginary line at right angles to the plane, at the point of the source/sink, along which we can think of the flow appearing/disappearing in the three-dimensional analogue of this flow.) This potential is undefined at the origin, as is  $w'(Z)$ ; at this point we therefore have a singularity. At every other point in the plane,  $w(Z)$  exists (and it is unique provided that we remain on one Riemann sheet).

**Note:** If the source/sink is moved to  $Z = Z_0$ , we have:

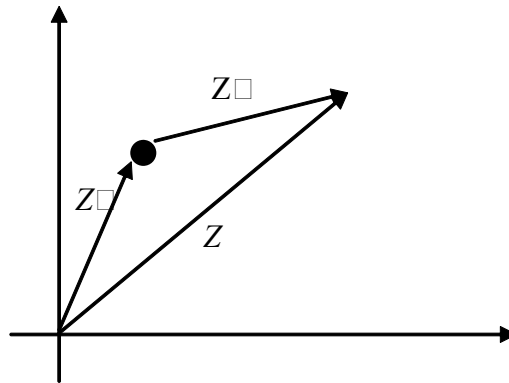

**Question:**  
What do Skype and Spotify have in common with color screen graphics and the computer mouse?

–They are all Swedish inventions.

STUDYINSWEDEN.SE



## Be innovative. Study in Sweden



and then we write  $\log Z_a = \log(Z - Z_o)$ , where  $Z_a$  is the coordinate measured from the singularity, as used in our derivation (and  $Z = Z_o + Z_a$ ; see figure). Thus for a source/sink, of strength  $m$  at  $Z = Z_o$ , the complex potential is

$$w(Z) = \frac{m}{2\pi} \log(Z - Z_o) .$$

**Example 21**

*Source + sink.* Write down the complex potential for the flow generated by a source of strength  $m$  at  $z = a$  ( $a$  real) and a sink of the same strength at  $z = ia$ . What is the velocity of the flow at the origin ?

---

This complex potential is obtained by simply adding the two complex potentials that describe, separately, the source and the sink:

$$w(Z) = \frac{m}{2\pi} \log(Z - a) - \frac{m}{2\pi} \log(Z - ia) .$$

We now form

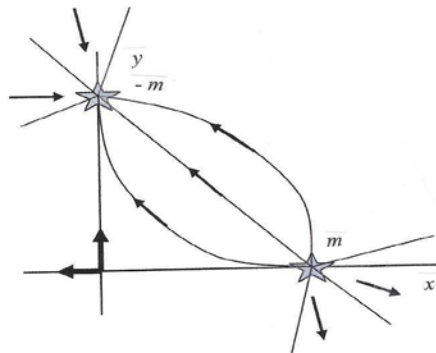

$$\frac{dw}{dZ} = \frac{m}{2\pi} \left( \frac{1}{Z - a} - \frac{1}{Z - ia} \right) \quad (= u - iv) \text{ which, at}$$

the origin, gives

$$u - iv = -\frac{m}{2\pi a} (1 + i) \text{ so } u = -\frac{m}{2\pi a}, v = \frac{m}{2\pi a} .$$

---

Note that, in this example, mass is conserved *globally*.

(c) Line (or point) vortex

This is a flow which moves (axi-symmetrically) in concentric circles about a fixed point, which we take to be at the origin:

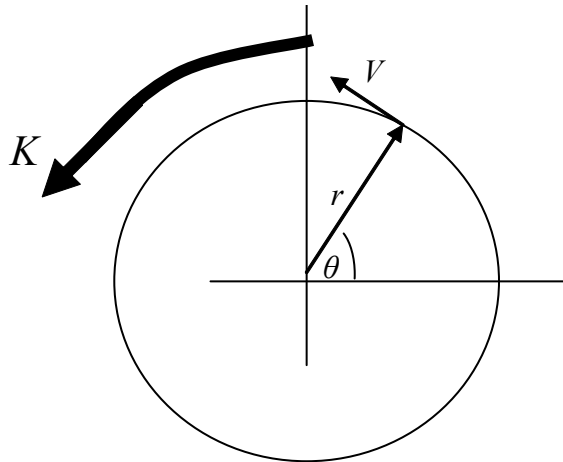

It is defined so that the circulation is the same constant at all radii, and so the circulation on any radius is

$$\oint_C \mathbf{u} \cdot d\mathbf{l} = 2\pi rV = K = \text{constant} \quad (\text{see Example 17}).$$

Thus we have

$$\frac{dw}{dZ} = u - iv = -V \sin \theta - iV \cos \theta = -iVe^{-i\theta}$$

and so

$$\frac{dw}{dZ} = -iVe^{-i\theta} = -i \frac{K}{2\pi r} e^{-i\theta} = -i \frac{K}{2\pi} \frac{1}{re^{-i\theta}} = -i \frac{K}{2\pi} \frac{1}{Z},$$

which gives  $w(Z) = -i \frac{K}{2\pi} \log Z$ .

If the vortex is at  $Z = Z_0$ , then the potential becomes  $w(Z) = -i \frac{K}{2\pi} \log(Z - Z_0)$ .

Note that the singularity in this potential is identical to that for a source/sink; the important difference is that, here, the multiplicative constant is pure imaginary – for the source/sink it is pure real. (Observe the sign: for anti-clockwise circulation,  $K$  is positive and the sign is minus.)

**Comment:** The complex potential derived here could have been obtained directly from that for the source/sink. To do this, notice that the component,  $V$ , is essentially  $U$  rotated through  $\pi/2$ ; so we may construct

$$Ue^{-i\theta} \rightarrow Ve^{-i(\theta+\pi/2)} = -iVe^{-i\theta}, \text{ and then use } V \text{ from above.}$$

**Example 22**

*Two line vortices.* A line vortex, of strength  $K$ , is placed at  $z = a$  ( $a$  real and positive), and one of strength  $-K$  is at  $z = -a$ . Show that the pair necessarily move, or that they must sit in a suitable uniform flow in order for them to remain fixed in the coordinate frame.

The complex potential that represents these two line vortices is

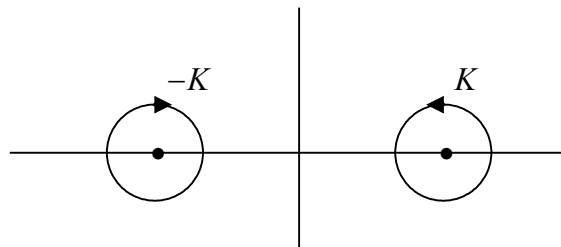

$$w(Z) = -\frac{iK}{2\pi} \log(Z - a) + \frac{iK}{2\pi} \log(Z + a),$$

and then

$$\frac{dw}{dZ} = \frac{iK}{2\pi} \left( \frac{1}{Z + a} - \frac{1}{Z - a} \right).$$

This expression, as expected, is undefined at  $Z = \pm a$ ; however, it is instructive to examine the behaviour of this function close to these two singularities.

Set  $Z = a + \delta$ , then  $\frac{dw}{dZ} = \frac{iK}{2\pi} \left( \frac{1}{2a + \delta} - \frac{1}{\delta} \right) \rightarrow \frac{iK}{4\pi a} + \text{sing.}$  as  $\delta \rightarrow 0$  (where 'sing.' denotes the term associated with the singularity at  $Z = a$  (as just mentioned)).

Now set  $Z = -a + \delta$ , then  $\frac{dw}{dZ} = \frac{iK}{2\pi} \left( \frac{1}{\delta} + \frac{1}{2a + \delta} \right) \rightarrow \text{sing.} + \frac{iK}{4\pi a}$  as  $\delta \rightarrow 0$ .

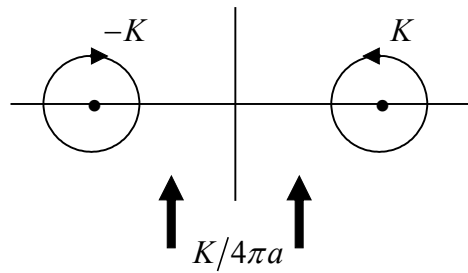

Thus, in addition to the flow field near the centre of each line vortex, generated by the singularity there, we have a uniform-flow contribution:  $v = -\frac{K}{4\pi a}$  i.e. the vortices move – the flow is time dependent! – and this induced motion of a pair of vortices is readily produced in the laboratory. In order to fix the line vortices in our coordinate frame, we must introduce a uniform stream to cancel this motion:

**THE BEST MASTER IN THE NETHERLANDS**

**Master of Science in Management**

Kickstart your career. Start your MSc in Management in September, graduate within 16 months and join 15,000 alumni from more than 80 countries.

Are you ready to take the challenge? Register for our MSc in Management Challenge and compete to win 1 of 3 partial-tuition revolving scholarships worth €10,000!

[www.nyenrode.nl/msc](http://www.nyenrode.nl/msc)

**NYENRODE BUSINESS UNIVERSITEIT**  
A REWARD FOR LIFE

**BEST MASTERS KEUZEGIDS MASTERS 2012**

\*Keuzegids Higher Education Masters 2012, in the category of business administration



**Example 23**

A row of vortices. Write down the complex potential for a row of line vortices, each of strength  $K$ , situated at  $z = 0, \pm a, \pm 2a, \dots, \pm na$  ( $a$  real and positive). Now let  $n \rightarrow \infty$ , use the identity

$$\sin\left(\frac{\pi z}{a}\right) = \frac{\pi z}{a} \prod_{n=1}^{\infty} \left(1 - \frac{z^2}{n^2 a^2}\right) \text{ (Mittag-Leffler),}$$

and hence find the resulting potential for an infinite row of vortices.

---

We have

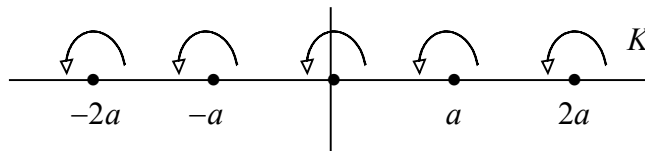

and so the complex potential for this row of line vortices is

$$\begin{aligned} w(Z) &= -\frac{iK}{2\pi} \log Z - \frac{iK}{2\pi} \log(Z - a) - \frac{iK}{2\pi} \log(Z + a) \dots \\ &\quad - \frac{iK}{2\pi} \log(Z - na) - \frac{iK}{2\pi} \log(Z + na) \\ &= -\frac{iK}{2\pi} \log \left[ Z(Z^2 - a^2)(Z^2 - 4a^2) \dots (Z^2 - n^2 a^2) \right] \\ &= -\frac{iK}{2\pi} \log \left[ \frac{\pi}{a} Z \left(1 - \frac{Z^2}{a^2}\right) \left(1 - \frac{Z^2}{4a^2}\right) \dots \left(1 - \frac{Z^2}{n^2 a^2}\right) \right] \end{aligned}$$

to within an additive constant.

We now let  $n \rightarrow \infty$ , and use the given (Mittag-Leffler) identity, to produce the complex potential for the infinite row of line vortices:

$$w(Z) = -\frac{iK}{2\pi} \log \left[ \sin \left( \frac{\pi Z}{a} \right) \right].$$

---

This result can be used to obtain the complex potential for two rows of line vortices as described in the next example (and this configuration has important applications).

**Example 24**

*Von Kármán street vortex.* Two infinite rows of vortices (as developed in Example 23) are placed: strength  $K$  at  $(0, b), (\pm 2a, b), (\pm 4a, b), \dots$ ; strength  $-K$  at  $(\pm a, -b), (\pm 3a, -b), \dots$ , for  $a > 0, b > 0$ . Write down the complex potential for this flow and find the speed at which that the pattern of vortices moves (cf. Example 22).

---

The configuration is shown in the figure; the two (infinite) rows of vortices are now shifted versions of those used in Ex.23, with a spacing replacing  $a$  by  $2a$ , and the two rows are a distance  $2b$  apart.

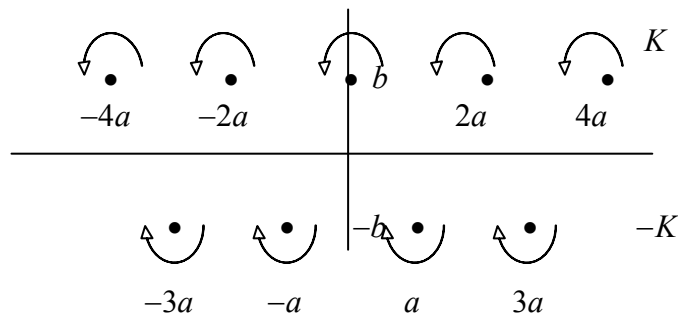

The complex potential for this system is then

$$w(Z) = -\frac{iK}{2\pi} \log \left[ \sin \left( \frac{\pi(Z - ib)}{2a} \right) \right] + \frac{iK}{2\pi} \log \left[ \sin \left( \frac{\pi(Z - a + ib)}{2a} \right) \right],$$

where the first term is generated by a shift of  $ib$ , and the second by  $a - ib$ . Now we have

$$\frac{dw}{dZ} = -\frac{iK}{4a} \cot \left( \frac{\pi(Z - ib)}{2a} \right) + \frac{iK}{4a} \cot \left( \frac{\pi(Z - a + ib)}{2a} \right),$$

and then near  $Z = ib \pm 2na$  we obtain

$$u - iv = (\text{sing.}) + \frac{iK}{4a} \cot \left( \frac{\pi(\pm 2na - a - ib)}{2a} \right).$$

The singular term is the expected contribution to the complex velocity – note the previous Example – and the other term can be written

$$\cot\left(\frac{\pi(\pm 2na - a - ib)}{2a}\right) = \cot\left(-\frac{\pi}{2} + i\pi\frac{b}{a}\right) = -\tan\left(i\pi\frac{b}{a}\right) = -i \tanh\left(\pi\frac{b}{a}\right).$$

Thus the second row moves, to the right, with a speed  $u = \frac{K}{4a} \tanh(\pi b/a)$ ; the corresponding calculation near  $Z = -ib \pm (2n + 1)a$  gives exactly the same speed for the first row i.e. the action of each row on the other is to move the whole configuration, at this speed, to the right; cf. Example 22.

---

## Turning a challenge into a learning curve. Just another day at the office for a high performer.

### Accenture Boot Camp – your toughest test yet

Choose Accenture for a career where the variety of opportunities and challenges allows you to make a difference every day. A place where you can develop your potential and grow professionally, working alongside talented colleagues. The only place where you can learn from our unrivalled experience, while helping our global clients achieve high performance. If this is your idea of a typical working day, then Accenture is the place to be.

It all starts at Boot Camp. It's 48 hours that will stimulate your mind and enhance your career prospects. You'll spend time with other students, top Accenture Consultants and special guests. An inspirational two days

packed with intellectual challenges and activities designed to let you discover what it really means to be a high performer in business. We can't tell you everything about Boot Camp, but expect a fast-paced, exhilarating

and intense learning experience. It could be your toughest test yet, which is exactly what will make it your biggest opportunity.

Find out more and apply online.

Visit [accenture.com/bootcamp](https://www.accenture.com/bootcamp)

• Consulting • Technology • Outsourcing

  
High performance. Delivered.



This example is relevant to the flow behind ‘bluff’ bodies, where there is a regular shedding of vortices, producing an ‘avenue’ of vortices moving downstream with the flow. The spacing of the vortices, and their speed, can be used (with the formula above) to determine the strength of the vortices being shed; a typical flow pattern is shown in the figure (the *von Kármán street vortex*):



This pattern is part of the reason why flags flutter in a moderately strong breeze: the flag pole acts as the bluff body, around which vortices are shed; the flag then, more-or-less, follows the flow induced behind the pole.

**(d) Dipole**

In this, our final ‘building block’ that we shall need, we construct a complex potential essentially as a mathematical exercise – we invent a  $w(Z)$  – and then examine the nature of the flow field that it represents. Here, we take a suitable limit of a source and a sink, of equal strengths (so mass, globally, is conserved). Consider a source of strength  $m$  at the point  $Z = ae^{i\alpha}$ , for given real constants  $a$  and  $\alpha$ ; a sink of equal strength (and so labelled  $-m$ ) is placed at the origin.

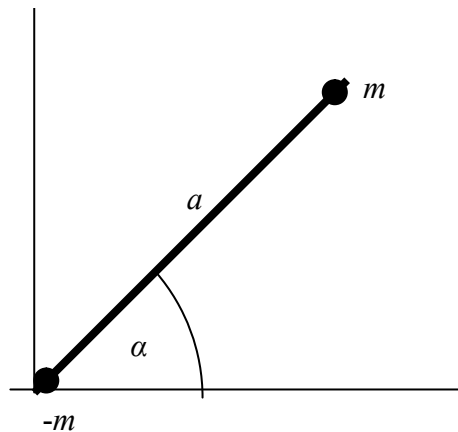

The complex potential for this flow is constructed by adding the two separate potentials:

$$w(Z) = \frac{m}{2\pi} \log(Z - ae^{i\alpha}) - \frac{m}{2\pi} \log Z = \frac{m}{2\pi} \log \left( 1 - \frac{ae^{i\alpha}}{Z} \right).$$

We now let  $a \rightarrow 0$ , at fixed  $\alpha$ , for any  $Z \neq 0$ ,  $a e^{i\alpha}$ ; this means that the source moves down the fixed straight line towards the sink at the origin. If we take this limit in the obvious way, then we obtain

$$w(Z) = \frac{m}{2\pi} \log \left( 1 - \frac{a e^{i\alpha}}{Z} \right) \rightarrow \frac{m}{2\pi} \log(1) = 0,$$

which is the expected result: the source and sink cancel out, leaving nothing at all. We therefore choose to take the limit in a special way: we let  $a \rightarrow 0$ , under the conditions already laid down, but also such that  $am$  remains fixed. Thus the strength increases as the distance between the source and sink decreases. To perform this limit, we first use the Maclaurin expansion of the log function:

$$\begin{aligned} w(Z) &= \frac{m}{2\pi} \log \left( 1 - \frac{a e^{i\alpha}}{Z} \right) = \frac{m}{2\pi} \left\{ -\frac{a e^{i\alpha}}{Z} - \frac{1}{2} \left( \frac{a e^{i\alpha}}{Z} \right)^2 \dots \right\} \\ &= -\frac{(am) e^{i\alpha}}{2\pi Z} - \frac{1}{2} (am) \frac{a e^{i2\alpha}}{2\pi Z^2} \dots \rightarrow -\frac{\mu e^{i\alpha}}{2\pi Z} \end{aligned}$$

where  $\mu = am$ , which is fixed. This new potential is called a *dipole* (and we will explain why shortly); it is of strength  $\mu$  and orientation (inclination)  $\alpha$ . It is clearly undefined at the origin; if it is positioned at  $Z = Z_0$  (where it will again be undefined), it becomes

$$w(Z) = -\frac{\mu}{2\pi} \frac{e^{i\alpha}}{(Z - Z_0)}.$$

So what is this new flow field that we have generated? For example: what are its streamlines?

To explore this aspect, we choose to write the potential (placed at the origin, for convenience) in terms of the polar representation:  $Z = r e^{i\theta}$ . The potential then becomes

$$w = \phi + i\psi = -\frac{\mu}{2\pi} \frac{1}{r} e^{i(\alpha - \theta)} = -\frac{\mu}{2\pi} \frac{1}{r} \{ \cos(\alpha - \theta) + i \sin(\alpha - \theta) \},$$

and so  $\psi(r, \theta) = -\frac{\mu}{2\pi r} \sin(\alpha - \theta)$ ;

the streamlines are therefore described by the curves

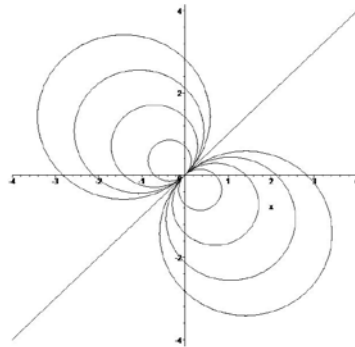

$$r = k \sin(\alpha - \theta),$$

where  $k$  is constant, with different constants on different streamlines. These curves are the set of all circles with the line  $\theta = \alpha$  as the tangent at the origin:

SIMPLY CLEVER



We will turn your CV into  
an opportunity of a lifetime



Do you like cars? Would you like to be a part of a successful brand?  
We will appreciate and reward both your enthusiasm and talent.  
Send us your CV. You will be surprised where it can take you.

Send us your CV on  
[www.employerforlife.com](http://www.employerforlife.com)



This set of curves is typically associated with the field lines of a bar magnet: a *dipole* magnet. (A discussion of these curves can be found in Exercise 77.)

We observe that, with  $\mu > 0$  and a given inclination  $\alpha$  (which is  $\pi/4$  in the figure above), the relative positions of the source and sink imply that the flow is *out* at the top and *in* at the bottom, the path of the flow following the circles around.

**Example 25**

*Source in a stream.* Write down the complex potential for a uniform flow (speed  $U$  parallel to the  $x$ -axis) past a source of strength  $m$  at the origin. Find the position of the stagnation point in this flow.

---

The flow is depicted in the figure; the complex potential for the uniform flow plus the source is then

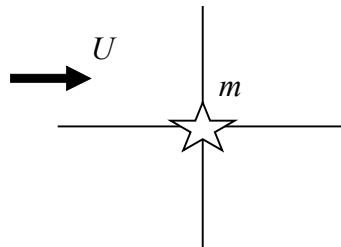

$$w(Z) = UZ + \frac{m}{2\pi} \log Z .$$

Thus  $\frac{dw}{dZ} = U + \frac{m}{2\pi} \frac{1}{Z}$ , which is zero (for a stagnation point) where  $Z = -\frac{m}{2\pi U}$ .

The stream function can also be obtained: set  $Z = re^{i\theta}$ , then

$$w = \phi + i\psi = Ur(\cos \theta + i \sin \theta) + \frac{m}{2\pi} (\ln r + i\theta) ;$$

thus  $\psi(r, \theta) = Ur \sin \theta + \frac{m}{2\pi} \theta = \text{constant}$  on SLs. The SL that passes through the stagnation point requires the choice: constant =  $m/2$ . Some of the details of the curves represented by  $Ur \sin \theta + \frac{m}{2\pi} \theta = \frac{m}{2}$  are discussed in Exercise 79; this curve has solutions  $\theta = \pi$  and another branch which passes through the stagnation point at right angles to the real axis, generating a special 'bluff' body.

---

The result of this calculation has an important interpretation. The boundary of the ‘bluff’ body, which separates the flow around the source from the external flow, can be regarded as the boundary defining the shape of a solid object. For both a solid object and a streamline (which this is), the boundary conditions are the same (for inviscid flow): flow along and no flow through/across. Thus we have a uniform flow past a specific shape, as shown below:

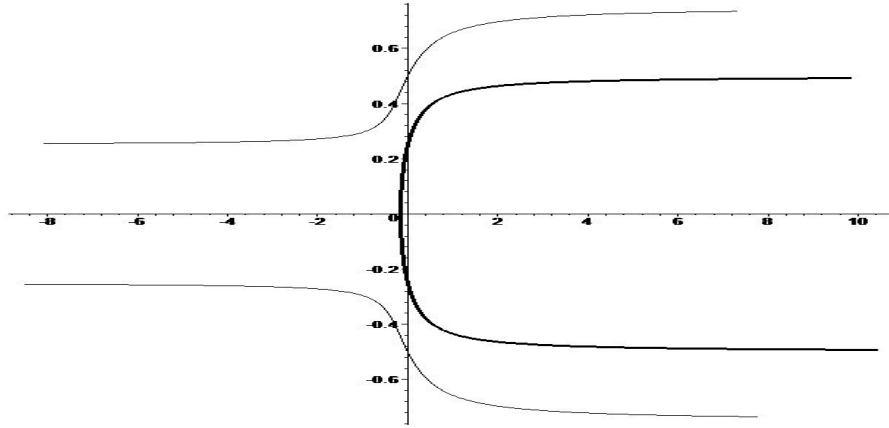

This idea provides a basis for modelling flows past objects. Further, we see that the source – which is a singularity in the plane – now appears only in the region occupied by the solid object (it is at the origin *inside* the body); the region where the flow (fluid) exists does *not contain any singularities*. A more complete representation of this flow is given in the figure below.

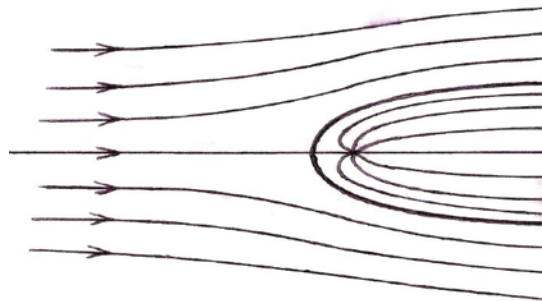

**Example 26**

*Dipole in a stream.* Write down the complex potential for a uniform flow (speed  $U$  parallel to the  $x$ -axis) past a dipole of strength  $-\mu$  ( $< 0$ ) situated at the origin, its alignment also being along the  $x$ -axis (i.e.  $\alpha = 0$ ). Find the position(s) of the stagnation points and hence determine the shape of the streamlines that pass through the point(s). Describe and interpret the flow field.

The flow is depicted in the figure; the complex potential for the uniform flow past the dipole – and note the change of orientation that leads to  $-\mu$  for  $\mu$  – is therefore

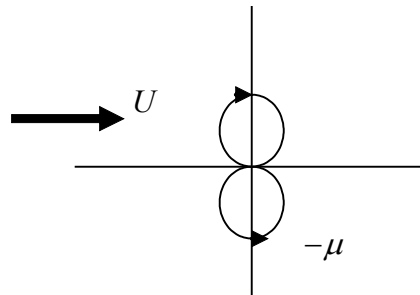

$$w(Z) = UZ - \frac{(-\mu)}{2\pi} \frac{1}{Z} = UZ + \frac{\mu}{2\pi} \frac{1}{Z}.$$

Thus  $\frac{dw}{dZ} = U - \frac{\mu}{2\pi} \frac{1}{Z^2}$ , and so the stagnation points are at

$$Z = \pm \sqrt{\frac{\mu}{2\pi U}}.$$

We introduce  $Z = re^{i\theta}$  to give

$$w = \phi + i\psi = Ur(\cos \theta + i \sin \theta) + \frac{\mu}{2\pi r}(\cos \theta - i \sin \theta),$$

and so the stream function becomes  $\psi(r, \theta) = Ur \sin \theta - \frac{\mu}{2\pi r} \sin \theta = \left( Ur - \frac{\mu}{2\pi r} \right) \sin \theta$ .

The streamlines are lines  $\psi = \text{constant}$ , and those through the stagnation points ( $\theta = 0, \theta = \pi; r = \sqrt{\mu/2\pi U}$ ) require  $\psi = 0$  i.e.  $\left( Ur - \frac{\mu}{2\pi r} \right) \sin \theta = 0$ . These streamlines are therefore all solutions of this equation, namely,

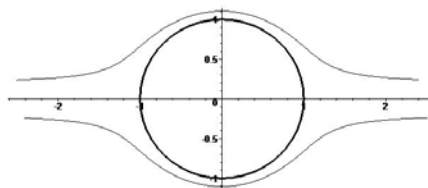

$$\theta = 0 (\forall r); \theta = \pi (\forall r); r = \sqrt{\mu/2\pi U} (\forall \theta).$$

Thus we have produced a model for uniform flow past a circle, as depicted in the figure.

**Summary:** These two examples demonstrate how we can model the flow (e.g. uniform flow) past an object with a specific shape. Typically, these shapes are constructed by placing, in the plane, suitable singularities (chosen to generate the shape) that appear only *inside the region* occupied by the object: the flow field remains singularity-free (as it must, for a realistic flow). However, we could allow vortices – and point vortices are singular at their centres – in the flow field, because mass is still conserved and the resulting circulatory flow often appears in real flows e.g. in the form of vortices shed off a bluff body. Even then, singularities can be avoided by choosing to have the vorticity distributed over a (small, finite) region, as in the Rankine vortex (Exercise 37).



**Brain power**

By 2020, wind could provide one-tenth of our planet's electricity needs. Already today, SKF's innovative know-how is crucial to running a large proportion of the world's wind turbines.

Up to 25 % of the generating costs relate to maintenance. These can be reduced dramatically thanks to our systems for on-line condition monitoring and automatic lubrication. We help make it more economical to create cleaner, cheaper energy out of thin air.

By sharing our experience, expertise, and creativity, industries can boost performance beyond expectations. Therefore we need the best employees who can meet this challenge!

The Power of Knowledge Engineering

Plug into The Power of Knowledge Engineering.  
Visit us at [www.skf.com/knowledge](http://www.skf.com/knowledge)

**SKF**



### 4.4 The method of images

As a small digression from our main theme, we mention a simple, standard technique for coping with simple boundaries. We will suppose that the region where the flow exists is bounded by straight walls (lines); these are solid walls which allow flow along them – the fluid is inviscid, remember – but not through them. Thus, as we have seen above, we can treat them as special streamlines. For example, we might have a flow in  $x > 0$  with a wall on  $x = 0$ :

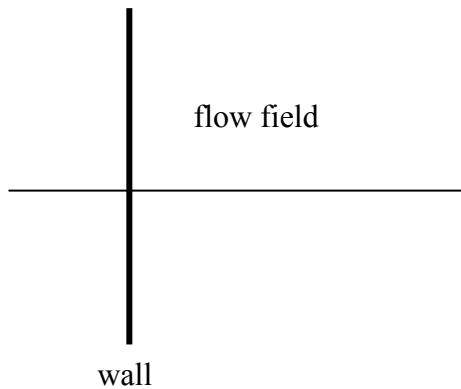

but we proceed by regarding the whole plane, initially, as a flow field; we shall then be able to analyse the flow properties in  $x > 0$ . (What happens in  $x < 0$  is altogether irrelevant: the flow here is merely used as a device for ensuring that we get the right shape of boundary; cf. the singularities inside the shapes in the two previous examples.) The simplest way to represent this flow, with the given boundary, is to invoke (mirror) symmetry: we place in  $x < 0$  the mirror image of the given flow in  $x > 0$ . This does not alter the given flow, and ensures that the boundary – by symmetry – is exactly that: no flow across it. We then say that the flow in  $x < 0$  is the *image* of the flow in  $x > 0$ . (The same terminology can be used in our two previous examples; thus we say that the *image of a uniform flow in a circle is a dipole*.) In this case, we then have the situation shown in the figure.

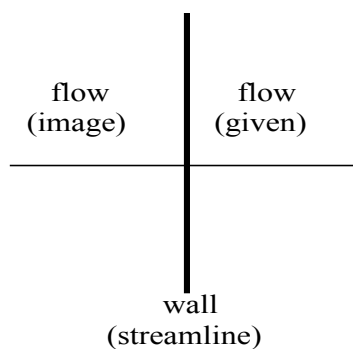

**Example 27**

Source with a boundary. A source of strength  $m$  is placed at  $(a,0)$ ,  $a > 0$ , where  $x = 0$  is a boundary. Find the complex potential for this flow and confirm that  $u = 0$  on  $x = 0$ ; (b) find an expression for the streamlines; (c) sketch the flow field.

We show the configuration, first without, and then with, the boundary (wall):



and then the complex potential for the two sources can be written as

$$w(Z) = \frac{m}{2\pi} \log(Z - a) + \frac{m}{2\pi} \log(Z + a) = \frac{m}{2\pi} \log(Z^2 - a^2)$$

(a) So we have  $\frac{dw}{dZ} = \frac{m}{2\pi} \left( \frac{2Z}{Z^2 - a^2} \right)$  which, on  $x = 0$  (the wall), gives

$$u - iv = \frac{m}{2\pi} \left( -\frac{2iy}{y^2 + a^2} \right) \Rightarrow u = 0.$$

(b) In order to address this problem, we need a general result. Suppose that we have

$$w = \phi + i\psi = \frac{m}{2\pi} \log[f(Z)],$$

then  $e^{2\pi\phi/m} [\cos(2\pi\psi/m) + i \sin(2\pi\psi/m)] = f(Z) = g(x, y) + ih(x, y)$  (say);

Since we require  $\psi$  (not  $\phi$ ), we take the ratio of the real and imaginary parts e.g.

$$\frac{h}{g} = \tan(2\pi\psi/m) = \text{constant on SLs.}$$

Thus we simply need to find the ratio of the real and imaginary parts of the function *inside* the log term. In this case, we have

$$f(Z) = Z^2 - a^2 = x^2 - y^2 - a^2 + 2ixy \text{ and so the SLs are } \frac{2xy}{x^2 - y^2 - a^2} = \text{const.}$$

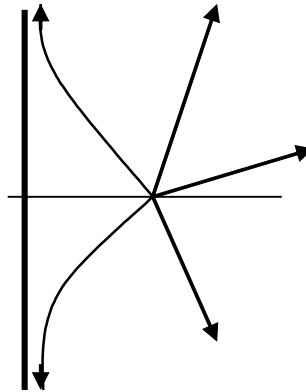

This can be expressed as  $\lambda xy = x^2 - y^2 - a^2$ , where  $\lambda$  is a constant which chooses a streamline.

(c) A simple sketch of the SLs:



This idea can be extended, as the next example demonstrates.

**Example 28**

*Source with two boundaries.* Find the complex potential for the flow generated by a source of strength  $m$  at the point  $(a, b)$  ( $a > 0, b > 0$ ) with boundaries along  $x = 0, y > 0$ , and  $y = 0, x > 0$ .

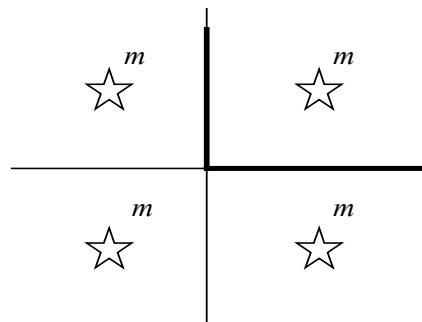

The source is at  $Z_0 = a + ib$  in the first quadrant; the image system is then three other identical sources, placed so that the complete coordinate axes are lines of symmetry; the relevant sections are therefore the walls (boundaries) that we require.

The complex potential for this system is

$$w(Z) = \frac{m}{2\pi} \left[ \log(Z - Z_0) + \log(Z - \bar{Z}_0) + \log(Z + Z_0) + \log(Z + \bar{Z}_0) \right]$$

$$= \frac{m}{2\pi} \log \left[ (Z^2 - Z_0^2)(Z^2 - \bar{Z}_0^2) \right].$$

**Comment:** We shall eventually require a representation of a uniform flow past a more complicated shape e.g. a section through a wing, usually called an 'aerofoil section':



What do you want to do?

No matter what you want out of your future career, an employer with a broad range of operations in a load of countries will always be the ticket. Working within the Volvo Group means more than 100,000 friends and colleagues in more than 185 countries all over the world. We offer graduates great career opportunities – check out the Career section at our web site [www.volvogroup.com](http://www.volvogroup.com). We look forward to getting to know you!

**VOLVO**  
AB Volvo (publ)  
[www.volvogroup.com](http://www.volvogroup.com)

VOLVO TRUCKS | RENAULT TRUCKS | MACK TRUCKS | VOLVO BUSES | VOLVO CONSTRUCTION EQUIPMENT | VOLVO PENTA | VOLVO AERO | VOLVO IT  
VOLVO FINANCIAL SERVICES | VOLVO 3P | VOLVO POWERTRAIN | VOLVO PARTS | VOLVO TECHNOLOGY | VOLVO LOGISTICS | BUSINESS AREA ASIA

Download free eBooks at [bookboon.com](http://bookboon.com)



Click on the ad to read more

It is far from obvious how to generate such a shape, but a first step is based on the complex potential for *any* flow past a *circle*. Although, in practice, we will be interested in only uniform flows, the mathematical idea here is important: it allows us to write the potentials for circles in any flow, even those that contain singularities. These are not of any great physical interest, with the possible exception of flows containing vortices, but they often provide useful exercises and also some insight into the nature of various flow fields. Then, once we are able to construct potentials for these flows, it becomes simply a matter of *changing the geometry* of the object – and this turns out to be surprisingly straightforward. Note: The presence of a circle is equivalent to introducing a circular wall – a boundary – into the flow, or, when we extend to 3D, the surface of a circular cylinder, with the plane being a slice across it. The cylinder is, of course, the usual object used in the laboratory to test the relevance of any theory associated with the (2D) circle.

### 4.5 The circle theorem (Milne-Thomson, 1940)

In order to motivate the general result, we consider the problem of uniform flow past a circle (see Example 26), but with the flow coming from a general direction. This is accomplished, based on that example, by ensuring that the flow out from the dipole meets the uniform flow head-on:

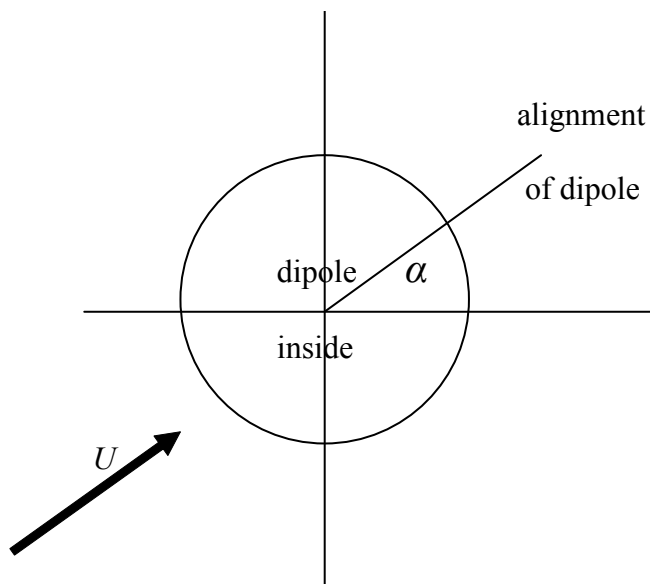

The complex potential is therefore

$$w(Z) = Ue^{-i\alpha}Z + \frac{a^2Ue^{i\alpha}}{Z},$$

where we have replaced the strength of the dipole,  $\mu$ , by the resulting radius of the circle generated:  $a = \sqrt{\mu/2\pi U}$  so  $\mu/2\pi = a^2U$ . Milne-Thomson noticed that this (special) result could be rewritten in the form

$$w(Z) = (Ue^{-i\alpha})Z + \overline{(Ue^{-i\alpha})} \frac{a^2}{Z},$$

where the over-bar denotes the complex conjugate. This suggested, to him, that this was an example of a more general result; this led to his circle theorem:

A flow is described by  $w(Z) = f(Z)$ , where  $f(Z)$  is analytic (no singularities) inside and on the circle  $|Z| = a$ . A circle  $|Z| = a$  is now placed in the flow; the complex potential that represents this new flow field is then

$$w(Z) = f(Z) + \bar{f}(a^2/Z),$$

where the conjugation of  $f$  is taken with the argument of this function fixed (and hence the reason for the short over-bar).

We now provide a proof of this theorem.

**Proof**

The proof comes in two parts. We need to show that the circle is a streamline of the new flow, so there is indeed a circle in the flow, and also that the flow outside the circle is essentially what it was before (with distortions, of course). This latter point amounts to the requirement that the way in which this flow is generated is not changed: it is the same flow field before the insertion of the circle. This, in turn, means that there should be no change to the singularities in the flow in  $|Z| > a$ : no singularities must disappear and none should appear. In the case of most interest – a uniform flow – if there are no singularities before the circle is inserted, there must be none afterwards.

(a) On  $|Z| = a$ , so that  $Z\bar{Z} = a^2$ , we have

$$w(Z)|_{|Z|=a} = f(Z) + \bar{f}(Z\bar{Z}/Z) = f(Z) + \bar{f}(\bar{Z}) = f(Z) + \overline{f(Z)},$$

which is pure real; thus  $\psi = 0$  on  $|Z| = a$ : the circle is a streamline.

(b) The given  $f(Z)$  is analytic for  $|Z| \leq a$ , then  $\bar{f}(a^2/Z)$  is analytic for  $|a^2/Z| \leq a$  (because conjugation changes only the relevant signs, not the sizes (distances)). Thus  $\bar{f}(a^2/Z)$  is analytic for  $|Z| \geq a$ , and so the analyticity outside (and on) the circle is not changed: no singularities are added and none are subtracted.

□

**Comment:** The flow at infinity, which is likely to be of interest when we are discussing uniform flows past objects, for example, is obtained by examining  $f(Z)$  alone, as  $|Z| \rightarrow \infty$ , because this same limit on the  $\bar{f}$  term corresponds to points *inside* the circle. Thus the behaviour at infinity is exactly that prescribed by the flow before the insertion of the circle.

**Example 29**

*Circle theorem.* Obtain the complex potential for the flow, generated by a source of strength  $m$  situated at  $(0,b)$ , past the circular cylinder  $|z| = a$ , where  $b > a$ . Interpret the image system.

Without the circle, the complex potential for the given flow is  $w(Z) = \frac{m}{2\pi} \log(Z - ib)$ ; since  $b > a$  we may use the MT circle theorem, with  $\bar{f}(\cdot) = \frac{m}{2\pi} \log(\cdot + ib)$ . Thus the complex potential for the same flow (due to the source outside the circle) past the circle  $|Z| = a$  is

$$w(Z) = \frac{m}{2\pi} \log(Z - ib) + \frac{m}{2\pi} \log\left(\frac{a^2}{Z} + ib\right).$$

In order to interpret this complex potential, we observe that

$$\frac{a^2}{Z} + ib = \frac{a^2 + ibZ}{Z} = ib \frac{(Z - ia^2/b)}{Z},$$

and so 
$$\frac{m}{2\pi} \log\left(\frac{a^2}{Z} + ib\right) = \frac{m}{2\pi} \log\left(Z - i\frac{a^2}{b}\right) - \frac{m}{2\pi} \log(Z) + \text{const.}$$

(where the additive constant is irrelevant). The first of these two terms represents a source (of strength  $m$ ) at  $Z = ia^2/b$ , which is inside the circle (because  $b > a$ ), and the second is a sink, of equal strength, at the origin.

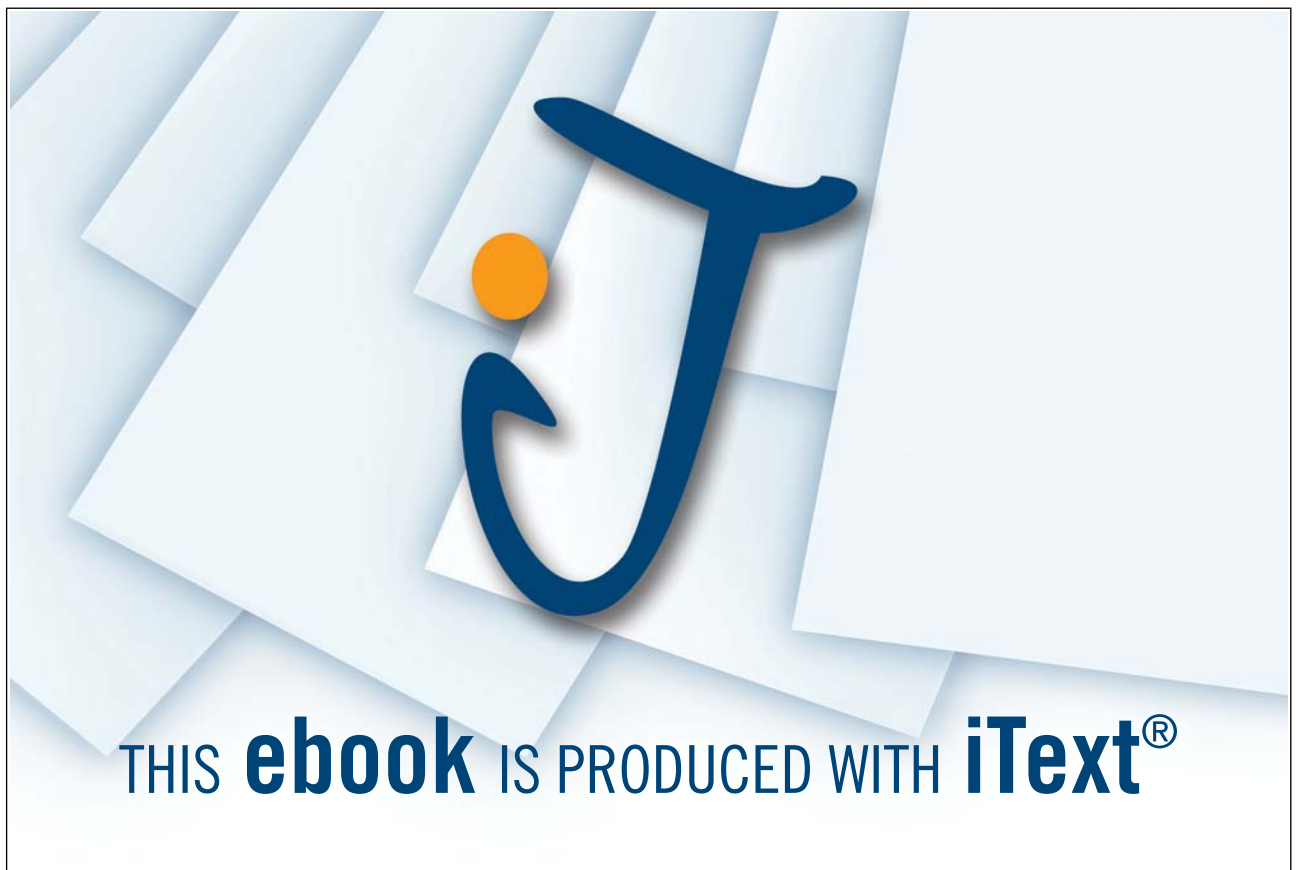

This figure depicts the flow, generated by a source, around a circle (in the orientation used in the example).

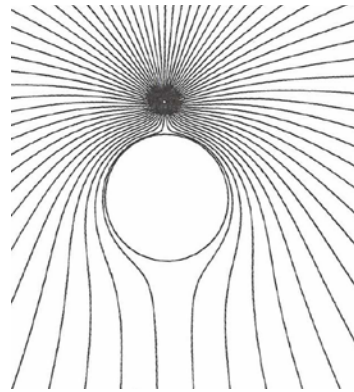

#### 4.6 Uniform flow past a circle

We start with Example 25 or, rather better in the current context, we use the Milne-Thomson (MT) circle theorem directly to construct the complex potential for uniform flow past a circle:

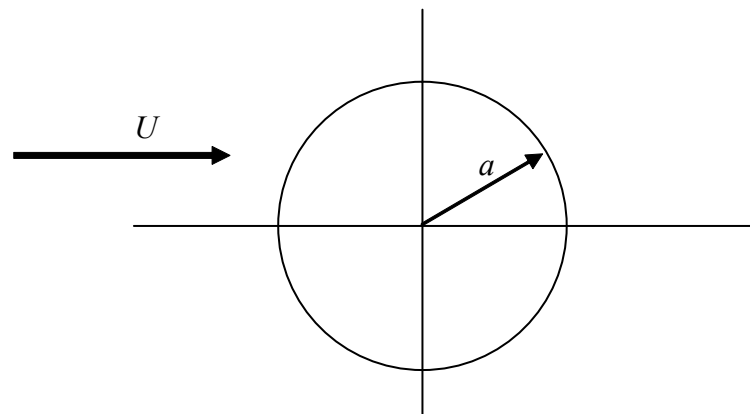

Here, the uniform flow is speed  $U$  parallel to the  $x$ - (real-) axis, past a circle, placed at the origin, of radius  $a$ ; the complex potential is therefore

$$w(Z) = UZ + U \frac{a^2}{Z}.$$

As we have done before, we choose to work with the polar form of the complex numbers, so we introduce  $Z = re^{i\theta}$  to give

$$w = \phi + i\psi = Ure^{i\theta} + \frac{Ua^2}{r} e^{-i\theta}.$$

The imaginary part of this expression then defines  $\psi$  as  $\psi(r, \theta) = U \left( r - \frac{a^2}{r} \right) \sin \theta$ , the stream function.

But the velocity components, in polar coordinates  $(r, \theta)$  (see §2.6 and Appendix 2), are

$$\mathbf{u} = \left( \frac{1}{r} \psi_{\theta}, -\psi_r \right) = \left( U \left\{ 1 - \frac{a^2}{r^2} \right\} \cos \theta, -U \left\{ 1 + \frac{a^2}{r^2} \right\} \sin \theta \right), \quad r \geq a,$$

and then on the circle,  $r = a$ , we obtain  $\mathbf{u} = (0, -2U \sin \theta)$ . This expression for the velocity on the surface of the circle demonstrates two properties: (1) the circle is a streamline, because there is flow only around it (i.e.  $u = 0$ ), as expected; (2) at  $\theta = 0, \pi$  there are stagnation points. In addition, surprisingly, the maximum speed on the circle is  $2U$ , which is twice the oncoming free stream! These occur at the positions  $\theta = \pi/2, 3\pi/2$ :

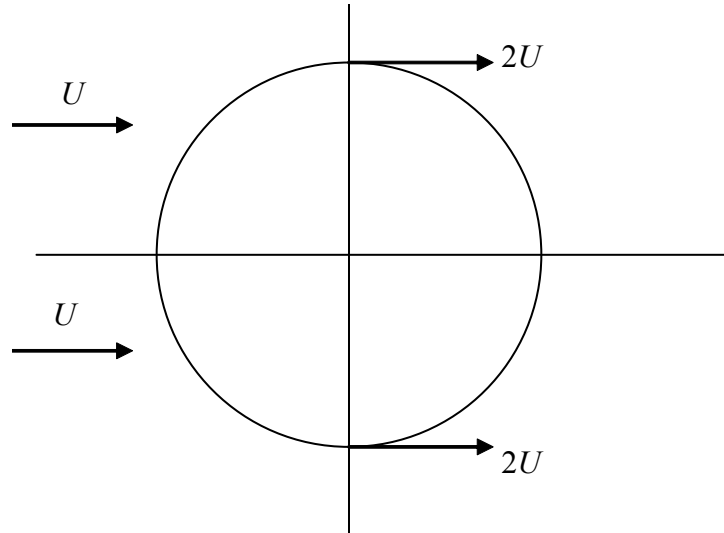

We now take this investigation one step further by calculating the pressure distribution around the circle. Let us assume that there are no body forces, and that the pressure at infinity is  $p_0$ ; remember that the flow is incompressible and, we have argued, body forces are negligible in the flows that we wish to examine. We apply Bernoulli's equation to the streamline that comes from infinity, goes around the circle and then moves off (to the right) back to infinity; thus we obtain

$$\frac{1}{2} U^2 + \frac{p_0}{\rho} = \text{constant} = \frac{p}{\rho} + \frac{1}{2} (-2U \sin \theta)^2,$$

where  $p = p(\theta)$  is the pressure on (around) the circle. This result is usually expressed as a *pressure coefficient*,  $C_p$ :

$$C_p = \frac{p - p_0}{\frac{1}{2} \rho U^2} = 1 - 4 \sin^2 \theta;$$

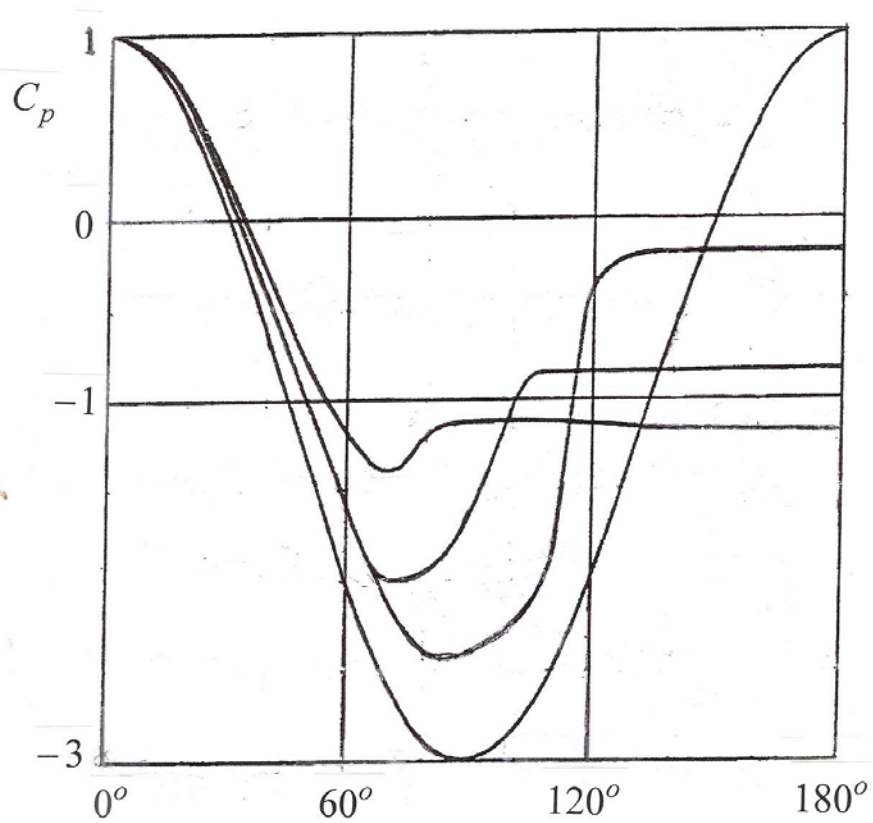

## Teach with the Best. Learn with the Best.

Agilent offers a wide variety of affordable, industry-leading electronic test equipment as well as knowledge-rich, on-line resources—for professors and students.

We have 100's of comprehensive web-based teaching tools, lab experiments, application notes, brochures, DVDs/CDs, posters, and more.



See what Agilent can do for you.  
[www.agilent.com/find/EDUstudents](http://www.agilent.com/find/EDUstudents)  
[www.agilent.com/find/EDUeducators](http://www.agilent.com/find/EDUeducators)

© Agilent Technologies, Inc. 2012

u.s. 1-800-829-4444    canada: 1-877-894-4414

Anticipate — Accelerate — Achieve



this describes the pressure around the circle, in a normalised form. We show some typical experimental results, as compared with the theoretical predictions (which is the curve that is drawn from 1 down to  $-3$  and then back up to 1). The other curves are based on experimental results, for various Reynolds numbers.

These results show that, typically, the pressure is close to this theoretical prediction only on the front of the circle (circular cylinder in the laboratory); on the back face, the pressure deviates significantly. (There is one exception to this: very slow flow produces the ideal flow, symmetric fore-and-aft, that was obtained in Example 26.) The deviation occurs because the flow *separates* from the surface of the cylinder, thereby generating a region of turbulent flow in its wake:

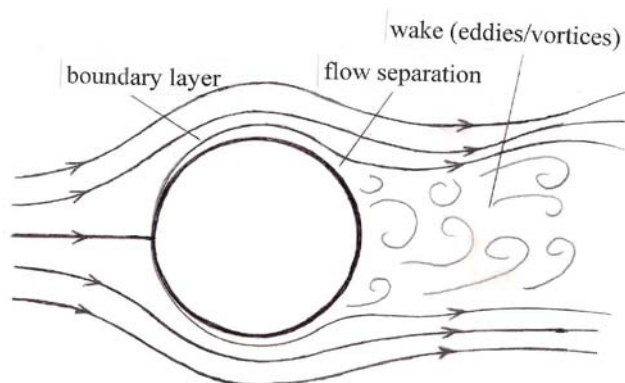

#### 4.7 Uniform flow past a spinning circle (circular cylinder)

As a precursor to our study of aerofoils and, in particular, that model which is needed to describe lift generation, we now look at the problem of uniform flow past a spinning circle (circular cylinder). The circle is spinning about its centre, the axis of rotation being at right angles to the (2D) flow field; the experimental evidence is that this spinning tends to remove the separation phenomenon mentioned above.

The spin, by virtue of the viscosity of the fluid, induces a circulatory motion in the fluid, which is superimposed on the uniform flow past the circle; this motion is what would be generated by a line vortex (at the origin) plus the uniform flow. The resulting flow field is therefore a combination both circulation and a uniform flow past the circle. We assume that the flow has settled to some steady state, albeit generated by viscous action, and then model the resulting flow by a suitable complex potential. This can be constructed, as before, by using the circle theorem – but with care! We know that we cannot allow a singularity in the flow, where the circle is to be placed, so we must start with no circulation (which will be centred at the origin). This is no surprise: we cannot induce circulation in the laboratory, by spinning, without first having the circle in place. When we remember that we may construct complex potentials simply by adding any (suitable) combination of simpler potentials, we may follow this recipe: uniform stream + circle + circulation, strictly in this order. This allows us to use the circle theorem to put the circle in the uniform stream – but we could just add the three relevant potentials, avoiding the use of the MT circle theorem. Thus we obtain

$$w(Z) = UZ + U \frac{a^2}{Z} + i \frac{K}{2\pi} \log Z ,$$

where we take  $K > 0$  to be the circulation (clockwise) induced in the flow by the spinning action; this potential is to be used in  $|Z| \geq a$ .

**Note:** If the circle (cylinder) is spinning at an angular speed  $\omega$ , then the fluid on the surface of the circle will be similarly rotating; thus the circulation is

$$K = \oint_C \mathbf{u} \cdot d\mathbf{l} = \int_0^{2\pi} a\omega \cdot a d\theta = 2\pi a^2 \omega,$$

since the speed of the flow, at  $r = a$ , in the angular ( $\theta$ ) sense, is  $a\omega$ .

As before, we elect to write  $Z = re^{i\theta}$ :

$$w = \phi + i\psi = Ure^{i\theta} + \frac{Ua^2}{r}e^{-i\theta} + i\frac{K}{2\pi}(\ln r + i\theta),$$

and so  $\psi(r, \theta) = U\left(r - \frac{a^2}{r}\right)\sin\theta + \frac{K}{2\pi}\ln r$ ;

note that  $r = a$  is still a streamline, but now associated with the constant  $\psi = \frac{K}{2\pi}\ln a$ . The velocity field becomes

$$\mathbf{u} = \left(\frac{1}{r}\psi_\theta, -\psi_r\right) = \left(U\left\{1 - \frac{a^2}{r^2}\right\}\cos\theta, -U\left\{1 + \frac{a^2}{r^2}\right\}\sin\theta - \frac{K}{2\pi r}\right),$$

and then stagnation points are where

$$u = U\left(1 - \frac{a^2}{r^2}\right)\cos\theta = 0, \quad v = -U\left(1 + \frac{a^2}{r^2}\right)\sin\theta - \frac{K}{2\pi r} = 0,$$

and these occur on  $r = a$  (as expected), but only if  $\sin\theta = -\frac{K}{4\pi aU}$ ; this has (real) solutions only for  $0 \leq K \leq 4\pi aU$ .

At equality, the two stagnation points coalesce; for  $K > 4\pi aU$  (i.e. sufficiently high spin rates) the solution corresponds to one stagnation point on  $\theta = 3\pi/2$ , outside the circle! (Some details of this can be found in Exercise 83.) These three cases are shown below:

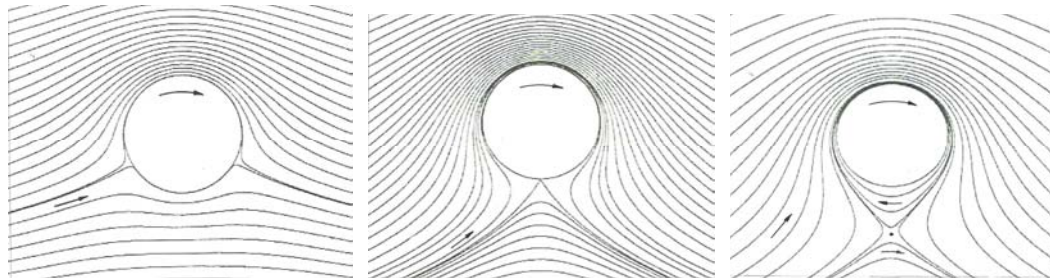





This is altogether amazing – but it is exactly what we find in the laboratory.

Download free eBooks at [bookboon.com](http://bookboon.com)

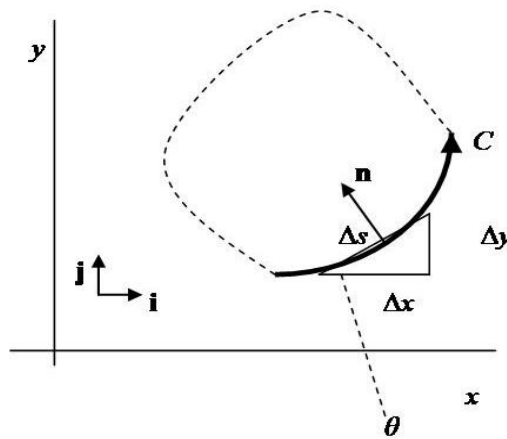

### 4.8 Forces on objects (Blasius' theorem, 1910)

We have seen that, given the velocity field, we can find the pressure (for example, from Bernoulli's equation); the total pressure around an object produces the resultant (pressure) force acting on the object. We develop this idea, and show that the methods of complex analysis lead to a very neat and powerful result. Consider an element of a (1D) closed surface,  $C$ , with inward unit normal  $\mathbf{n}$ :



Find and follow us: <http://twitter.com/bioradlscareers>  
[www.linkedin.com/groupsDirectory](http://www.linkedin.com/groupsDirectory), search for Bio-Rad Life Sciences Careers  
<http://bio-radlifesciencescareersblog.blogspot.com>



## Your Profession is Your Passion. Pass it On.

John Randall, PhD  
Senior Marketing Manager, Bio-Plex Business Unit

Bio-Rad is a longtime leader in the life science research industry and has been voted one of the Best Places to Work by our employees in the San Francisco Bay Area. Bring out your best in one of our many positions in research and development, sales, marketing, operations, and software development. Opportunities await — share your passion at Bio-Rad!

[www.bio-rad.com/careers](http://www.bio-rad.com/careers)





then the total pressure force on this curve is

$$\oint_C p \mathbf{n} \, ds, \text{ where } dS = 1 \times ds$$

(and so the force is per unit length out of the plane). But the unit normal can be expressed in terms of the unit vectors associated with the two coordinate directions:

$$\mathbf{n} = \mathbf{j} \cos \theta - \mathbf{i} \sin \theta$$

with  $\frac{dx}{ds} = \cos \theta$  and  $\frac{dy}{ds} = \sin \theta$ . Thus the resultant (i.e. total) force is

$$\oint_C p(\mathbf{j} dx - \mathbf{i} dy) \text{ (per unit length);}$$

it is convenient to define the two components of the force as

$$X = -\oint_C p \, dy \text{ and } Y = \oint_C p \, dx.$$

Similarly, we can define the moment of these forces about the origin:

$$M = \oint_C (px \, dx + py \, dy),$$

where the corresponding moment arms are  $x$  and  $y$ . The configuration therefore takes the form shown below:

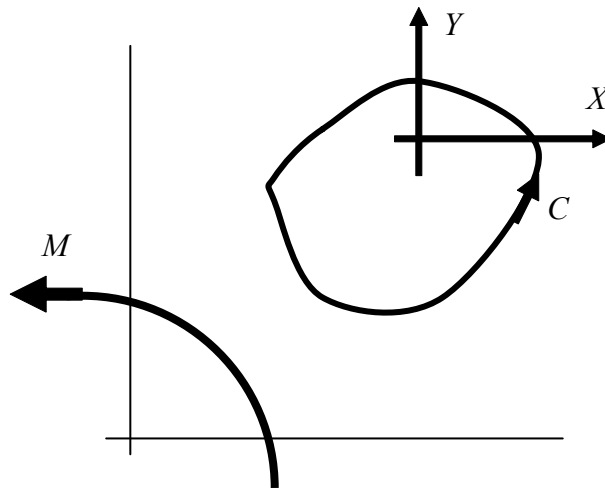

We now introduce a *complex force*:

$$X - iY = \oint_C (-p \, dy - ip \, dx) = -i \oint_C p(dx - idy) = -i \oint_C p \, d\bar{Z}.$$

But on streamlines (and  $C$  is a streamline), we have Bernoulli's equation

$$\frac{1}{2} \mathbf{u} \cdot \mathbf{u} + \frac{p}{\rho} = \text{constant} \quad (\text{in the absence of body forces}),$$

where we may write  $\frac{dw}{dZ} = u - iv$ , and so  $\mathbf{u} \cdot \mathbf{u} = u^2 + v^2 = \left(\frac{dw}{dZ}\right)\overline{\left(\frac{dw}{dZ}\right)}$ ; thus

$$p = -\frac{1}{2} \rho \left(\frac{dw}{dZ}\right)\overline{\left(\frac{dw}{dZ}\right)} + \text{constant}.$$

However, we have  $\overline{\left(\frac{dw}{dZ}\right)} = \frac{d\bar{w}}{d\bar{Z}}$  (because, for example,  $\overline{\left(\frac{dw}{dZ}\right)} = \overline{f'(Z)} = \bar{f}'(\bar{Z})$ ), and so we obtain

$$X - iY = \frac{1}{2} i \rho \oint_C \left\{ \left(\frac{dw}{dZ}\right)\overline{\left(\frac{d\bar{w}}{d\bar{Z}}\right)} + \text{constant} \right\} d\bar{Z},$$

where  $\oint_C (\text{constant}) d\bar{Z} = 0$  (because a constant is an analytic function of  $\bar{Z}$  - or simply do the integration directly). Finally, since  $w = \phi + i\psi$  then  $\bar{w} = \phi - i\psi$ , and so  $dw = d\bar{w} (= d\phi)$  on streamlines (where  $\psi = \text{constant}$ ); thus

$$\oint_C \left(\frac{dw}{dZ}\right)\overline{\left(\frac{d\bar{w}}{d\bar{Z}}\right)} d\bar{Z} = \oint_C \left(\frac{dw}{dZ}\right) d\bar{w} = \oint_C \left(\frac{dw}{dZ}\right) dw = \oint_C \left(\frac{dw}{dZ}\right)^2 dZ.$$

The complex force can therefore be written as the contour integral in the complex plane:

$$X - iY = \frac{1}{2} i \rho \oint_C \left(\frac{dw}{dZ}\right)^2 dZ;$$

this is *Blasius' theorem for forces*.

A similar argument produces an expression for the moment of these forces about the origin:

$$M = \Re \left\{ -\frac{1}{2} \rho \oint_C Z \left(\frac{dw}{dZ}\right)^2 dZ \right\} \quad (\text{denoting the real part}).$$

[H. Blasius did this, and the work on the flat-plate boundary layer, for his PhD (supervised by Prandtl); he wrote a book on mechanics in 1933.]

The problem of finding the components of the force (and the moment) acting on a body in a flow has become a standard exercise in complex integration in the complex plane. This involves the application of Cauchy's integral theorems, following the identification of poles and the evaluation of residues; some readers may wish to revise this material on complex integration at this stage. We present two examples that demonstrate how the standard techniques can be applied; the second example here is particularly important, with far-reaching consequences (and also with some direct applications).

**Example 30**

*Forces.* A source of strength  $m$  is situated at the point  $(b,0)$ , outside the circle  $|z| = a$  ( $b > a$ ). What force is exerted on the circular cylinder?

[The result of this calculation may surprise.]

The complex potential for this flow is

$$\begin{aligned}
 w(Z) &= \frac{m}{2\pi} \log(Z - b) + \frac{m}{2\pi} \log\left(\frac{a^2}{Z} - b\right) \\
 &= \frac{m}{2\pi} \log(Z - b) + \frac{m}{2\pi} \log\left(Z - \frac{a^2}{b}\right) - \frac{m}{2\pi} \log Z + \text{constant},
 \end{aligned}$$

and so

$$\frac{dw}{dZ} = \frac{m}{2\pi} \left( \frac{1}{Z - b} + \frac{1}{Z - a^2/b} - \frac{1}{Z} \right).$$



ericsson.com

**Shaping tomorrow's world – today**

Our business is at the heart of a connected world – a world where communication is empowering people, business and society. Our networks, telecom services and multimedia solutions are shaping tomorrow. And this might just be your chance to shape your own future.

**It's a people thing**

We are looking for high-caliber people who can see the opportunities, people who can bring knowledge, energy and vision to our organization. In return we offer the chance to work with cutting-edge technology, personal and professional development, and the opportunity to make a difference in a truly global company.

We are currently recruiting both new graduates and experienced professionals in four areas: **Software, Hardware, Systems and Integration & Verification.**

Are you ready to shape your future? Begin by exploring a career with Ericsson. Visit [www.ericsson.com/join-ericsson](http://www.ericsson.com/join-ericsson)



Now the value of the contour integral (in Blasius' theorem) requires the residues of  $(dw/dZ)^2$  at the poles inside the contour,  $C$  (the circle here), which are at  $Z = 0$ ,  $Z = a^2/b$ . Because we automatically generate the form of the relevant terms in the Laurent expansion of this function, we need take note of only the terms of the form  $1/(Z - Z_0)$ . Thus we write

$$\left(\frac{dw}{dZ}\right)^2 = \frac{m^2}{4\pi^2} \left[ \frac{2}{(Z-b)(Z-a^2/b)} - \frac{2}{Z(Z-b)} - \frac{2}{Z(Z-a^2/b)} + \dots \right],$$

where the terms omitted are the various squares obtained by squaring the expression – and these cannot contribute to the residue. We now 'read off' the residues:

$$\text{at } Z = 0: \quad \frac{m^2}{4\pi^2} \left[ \frac{2}{b} + \frac{2}{a^2/b} \right] = \frac{m^2}{2\pi^2} \left[ \frac{1}{b} + \frac{b}{a^2} \right];$$

$$\text{at } Z = a^2/b: \quad \frac{m^2}{4\pi^2} \left[ \frac{2}{a^2/b - b} - \frac{2}{a^2/b} \right] = \frac{m^2}{2\pi^2} \left[ \frac{b}{a^2 - b^2} - \frac{b}{a^2} \right].$$

Thus, using the Residue Theorem, we obtain

$$X - iY = \frac{1}{2} i\rho \cdot 2\pi i \cdot \frac{m^2}{2\pi^2} \left[ \frac{1}{b} + \frac{b}{a^2} + \frac{b}{a^2 - b^2} - \frac{b}{a^2} \right] = \frac{\rho m^2}{2\pi} \cdot \frac{a^2}{b(b^2 - a^2)} > 0,$$

which is the value of  $X$ , and  $Y = 0$ . This result shows that the force on the circle (or per unit length on the circular cylinder) is *towards* the source i.e. it is sucked towards the source, rather than being blown away from it (as we might have expected).

**Comment:** The reason for this rather surprising result comes about because of the nature of a source flow. The speeds are very high close to the source, and so the pressures are very low; the speeds further away, near the circle, for example, are much lower, producing a higher pressure. This effect is stronger than the acceleration of the flow around the circle, thereby producing a lower pressure on the face nearest the source: the circle is pushed towards the source.

**Example 31**

*Force on a spinning circular cylinder.* Find the force on a spinning circular cylinder (circulation  $K$ , clockwise) which is placed in the uniform flow of speed  $U$ , moving parallel to the real axis and to the right.

---

[The result of this calculation is important and fundamental: it constitutes the *Kutta-Joukowski theorem* (1902, 1906).]

The complex potential for this flow (see §4.7) is

$$w(Z) = UZ + U \frac{a^2}{Z} + i \frac{K}{2\pi} \log Z,$$

and then we have  $\frac{dw}{dZ} = U \left( 1 - \frac{a^2}{Z^2} \right) + \frac{iK}{2\pi} \frac{1}{Z}$ , so  $\left( \frac{dw}{dZ} \right)^2 = \left[ U \left( 1 - \frac{a^2}{Z^2} \right) + \frac{iK}{2\pi} \frac{1}{Z} \right]^2$ .

The only pole inside the circle is at  $Z = 0$ , and then the only term that contributes to the residue is of the form  $1/Z$ :

$$2U \cdot \frac{iK}{2\pi}; \text{ thus}$$

$$X - iY = \frac{1}{2} i \rho \cdot 2\pi i \cdot \frac{iUK}{\pi} = -i\rho UK.$$

The force is therefore  $X = 0, Y = \rho UK$ : the force on a spinning circle (circular cylinder) is at right angles to the oncoming stream.

---

This example demonstrates how spinning objects, in a flow, generate a sideways force; this was first observed by Robins (1742) and then investigated by Magnus (1853) – and both names have been associated with the phenomenon. The application to the propulsion of a ship was developed by Flettner in the mid-1920s. The effect is also very evident in various ball games e.g. golf, football and tennis; the cricket ball also uses this property, but many other effects are present in this case! Note that the force generated by the circulation and the oncoming stream is at *right angles* to that stream: motion (or flow) in one direction produces a force at right angles to this direction – we may have the basis for lift. Schematically, we therefore have a circle with circulation (clockwise) and a flow from left to right; the force is then leftwards, relative to the oncoming stream:

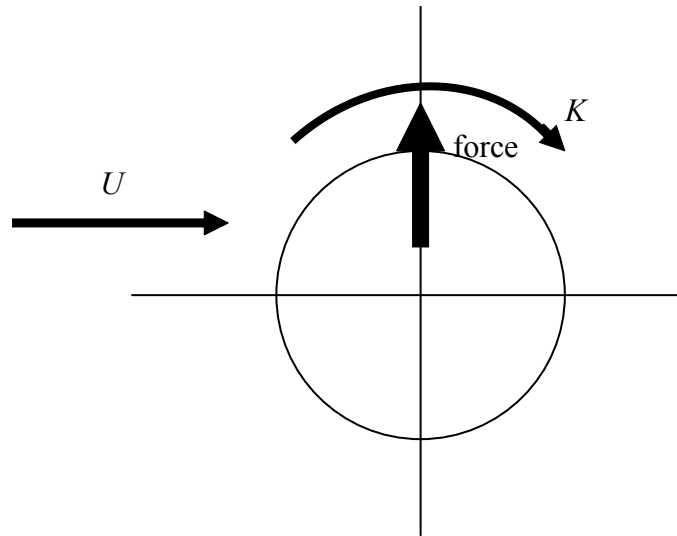

Handwritten mathematical notes and diagrams on a blackboard background. The notes include:

- $SGE = ARCHBIN = 1 \times 24 - and, 50/64 - and$
- $-cpn - c = 0.9$
- $-mem\_free = 1.5G$
- $SGE - MEA$
- Diagrams showing boxes labeled "q transfer", "shadow", "Prod", and "Cell = pub".
- Equations like  $DCU + 3360$  and  $100g + 800,000$ .
- Other terms like "Queue = delay, back log, priority, packet, interactive ...", "projects = delay ...", and "global  $\rightarrow$  P/B".

## The D. E. Shaw group is hiring. You can do the math.

Meet us on-campus this semester.  
Check out [www.deshaw.com](http://www.deshaw.com) for more info.

Handwritten mathematical notes and diagrams on a blackboard background. The notes include:

- Diagrams showing boxes and lines, possibly representing a network or data flow.
- Equations like  $+4 1000$  and  $+4 1000$ .
- Text "D E Shaw & Co" in the center.
- Other terms like "NJ2 NJ3 vs NJT NJT vs NJN NJN".



### 4.9 Conformal transformations

In our discussions so far, we have developed techniques that enable us to construct models for flows around circles; primarily, this involves the application of the Milne-Thomson circle theorem. Once we have the complex potential, we can use the Blasius theorems (for forces and the moment) to find the effects of the flow on the circle (circular cylinder). The issue that we must now address is: how do we apply these ideas to other shapes? These shapes will be described by bounded curves – so no walls that extend to infinity – and should include shapes like aerofoils:



The technique that we develop involves mapping between two complex planes:

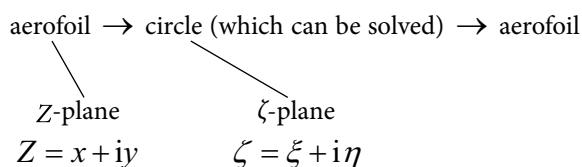

with a mapping  $Z = F(\zeta)$ . This mapping must be one-to-one, at least in the region occupied by the fluid and the boundary of the shape; it is only points in this region which are described by the complex potential – the rest of the plane (the interior of the boundary defining the shape) is replaced by a solid body. Then the process involves mapping from the ‘physical plane’, which contains the aerofoil, to the auxiliary plane containing the circle; this problem is solved completely (whatever that might mean) and then the results are mapped back to the physical plane. Clearly, we need to discuss the properties of such a transformation. A suitable transformation must produce the required shape (aerofoil to circle to aerofoil), and also generate all the required properties of the flow past the aerofoil e.g. the force and moment. First, we will discuss the general notion of such a transformation, and then (in the next chapter) describe the particular transformation that possesses all the properties that we require. Then we will describe, in great detail, the properties of the relevant transformation, whereas here we will approach the issues within a more general framework.

The transformations that we work with are called ‘conformal’; we describe what this means. Consider three neighbouring points in the  $Z$ -plane, and the three points that they map to in the  $\zeta$ -plane; we assume, at the outset, that the points under discussion satisfy the one-to-one property.

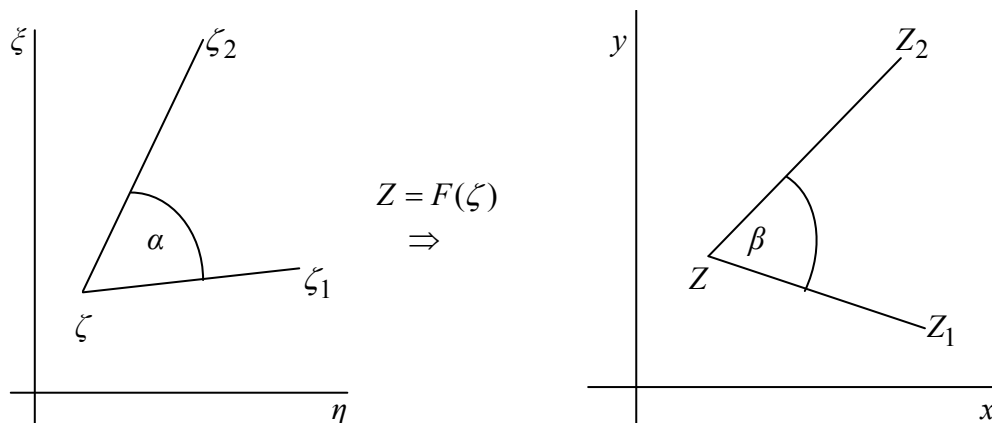

We form

$$\frac{Z_1 - Z}{\zeta_1 - \zeta} = \frac{F(\zeta_1) - F(\zeta)}{\zeta_1 - \zeta} \quad \text{and} \quad \frac{Z_2 - Z}{\zeta_2 - \zeta} = \frac{F(\zeta_2) - F(\zeta)}{\zeta_2 - \zeta},$$

and then perform the limiting processes:  $\zeta_1 \rightarrow \zeta$  and  $\zeta_2 \rightarrow \zeta$ , at fixed  $\alpha$ . (It is assumed that the mapping remains one-to-one at every point on the lines between  $\zeta$  and  $\zeta_1$ , and between  $\zeta$  and  $\zeta_2$ .) The result, provided that  $F'(\zeta)$  exists and is non-zero, is that

$$\lim_{\zeta_1 \rightarrow \zeta} \left[ \frac{F(\zeta_1) - F(\zeta)}{\zeta_1 - \zeta} \right] = F'(\zeta) = \lim_{\zeta_2 \rightarrow \zeta} \left[ \frac{F(\zeta_2) - F(\zeta)}{\zeta_2 - \zeta} \right],$$

i.e.

$$\lim_{\zeta_1 \rightarrow \zeta} \left[ \frac{F(\zeta_1) - F(\zeta)}{\zeta_1 - \zeta} \right] = \lim_{\zeta_2 \rightarrow \zeta} \left[ \frac{F(\zeta_2) - F(\zeta)}{\zeta_2 - \zeta} \right].$$

In particular, as the limit is approached, we have the geometrical property

$$\arg(Z_1 - Z) - \arg(\zeta_1 - \zeta) = \arg(Z_2 - Z) - \arg(\zeta_2 - \zeta)$$

and so

$$\arg(\zeta_2 - \zeta) - \arg(\zeta_1 - \zeta) = \arg(Z_2 - Z) - \arg(Z_1 - Z)$$

or  $\alpha = \beta$ .

Thus, at points where  $F'(\zeta)$  exists and is non-zero, the transformation  $Z = F(\zeta)$  preserves angles; this is the essential feature of a *conformal transformation*. Indeed, even where, exceptionally, angles are not preserved – but they are everywhere else in the plane – we still call the transformation ‘conformal’. Points where conformality fails are called *branch* or *critical* points of the transformation. At these points, either  $F'(\zeta)$  is undefined i.e. its value approaches infinity as the point is approached, and so the determination of a direction is impossible; similarly, if  $F'(\zeta)$  is zero at the point, the direction is not unique – the determination of angle again fails.

**Note:** Smooth curves, where the local angle is  $\pi$  (the tangent), map into smooth curves – the same angle  $\pi$  – away from critical points of the transformation. At the critical points, the particular transformation must be examined in order to determine what happens at each. We shall see how this is done in the case of the transformation that we use for the generation of aerofoil shapes, in Chapter 5.

**Example 32**

*Conformal transformation.* Consider the region  $0 \leq \theta \leq \alpha, r \geq 0$  in the  $\zeta$ -plane, under the transformation  $Z = F(\zeta) = \zeta^{\pi/\alpha}$ ; find the corresponding region in the  $Z$ -plane.

The two planes are shown here, where the line  $\zeta = r$  becomes  $Z = r^{\pi/\alpha}$ , and  $\zeta = re^{i\alpha}$  becomes  $Z = r^{\pi/\alpha}e^{i\pi} = -r^{\pi/\alpha}$ . Further, any point interior to the ‘wedge’

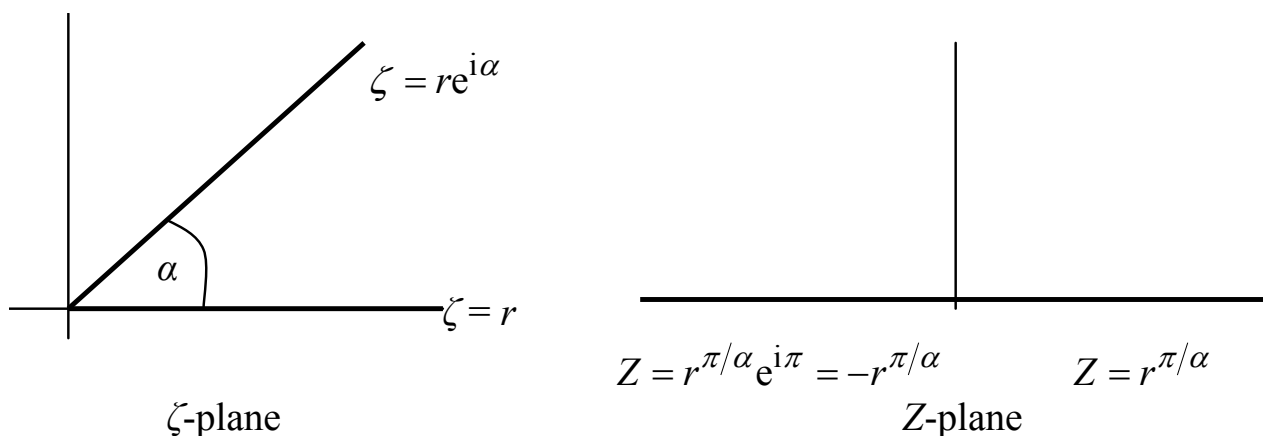

region in the  $\zeta$ -plane,  $\zeta = re^{i\theta}, 0 < \theta < \alpha$ , maps to  $Z = r^{\pi/\alpha}e^{i\pi\theta/\alpha}, 0 < \theta\pi/\alpha < \pi$ , which is in the upper half-plane. Thus the wedge region, and its boundaries, map to the upper half-plane, with the real axis becoming the boundary.

**Note:** In this previous example, we have  $F'(\zeta) = \frac{\pi}{\alpha}\zeta^{\pi/\alpha-1}$ ; if  $0 < \pi/\alpha < 1$ , then  $F'(\zeta)$  is undefined at  $\zeta = 0$ ; if  $\pi/\alpha > 1$ , then  $F'(\zeta)$  is zero at  $\zeta = 0$ ; in both cases, conformality fails (and here, as we have seen, the angle at the origin changes from  $\alpha$  to  $\pi$ ). If  $\alpha = \pi$ , the transformation is simply an identity: nothing changes.

## 4.10 The transformation of flows

In the previous section, we considered, briefly, the problem of transforming between shapes; now we examine how this same principle – applying a conformal transformation – works for flows represented by a complex potential. We assume that the conformal transformations are one-to-one in the region occupied by the flow and the boundary of the object placed in the flow; we do not apply the transformation to points inside the boundary i.e. points that are within the solid object. Suppose that we have a complex potential  $w(Z)$ , describing the flow in the  $Z$ -plane, and a conformal transformation (in the sense developed earlier, so it may contain a finite number of points where conformality fails) represented by  $Z = F(\zeta)$ . The resulting potential in the  $\zeta$ -plane is then

$$W(\zeta) = w\{F(\zeta)\};$$

we now investigate the properties of this new potential.

(a) **Streamlines** (and so boundaries of objects)

A streamline,  $C$ , in the  $Z$ -plane, is defined by

$$\Im(w) = \text{constant} \quad (\text{denoting the imaginary part}) \text{ on } C.$$

It's only an opportunity if you act on it

IKEA.SE/STUDENT

© Inter IKEA Systems B.V. 2009

Reduce Reuse Recycle

WORK WITH US

to gether ness

save water. Shower together

everyone deserves good design

IKEA

Let  $\Gamma$ , a curve in the  $\zeta$ -plane, map into the curve  $C$ ; then we have

$$\Im[W(\zeta)]|_{\Gamma} = \Im[w(F(\zeta))]|_{\Gamma} = \Im[w(Z)]|_C = \text{constant},$$

and so streamlines map into streamlines.

**(b) Flow at infinity**

The flow at infinity, in the  $Z$ -plane, is obtained by examining the behaviour of  $w(Z)$  as  $|Z| \rightarrow \infty$ ; correspondingly, for the flow in the  $\zeta$ -plane, we examine  $W(\zeta)$  as  $|\zeta| \rightarrow \infty$ . Thus, if  $F(\zeta)$  has the property:  $F(\zeta) \approx \zeta$ , as  $|\zeta| \rightarrow \infty$ , then the flows in the two planes, at infinity, are identical i.e.

$$W(\zeta) = w(F(\zeta)) \approx w(\zeta) \text{ as } |\zeta| \rightarrow \infty.$$

An example with this property is the transformation

$$F(\zeta) = \zeta + \frac{1}{\zeta},$$

which is precisely the form that we shall discuss in the next chapter. We often aim to use transforms that satisfy this property. Then the flow past a shape maps into the same flow past a different shape e.g. uniform flow past a circle maps to uniform flow past an aerofoil (and *vice versa*).

**(c) Singularities**

From what we have seen so far, it must be assumed that singularities (sources, dipoles, etc.) are likely to be important in the complex potentials that we discuss (because they will be used to construct the shapes of objects in the flow). Of course, we must hope that any singularities do not appear ‘naked’ in the flow field.

Let there be a singularity at  $Z = Z_0$  in the  $Z$ -plane, but such that  $Z_0$  does not coincide with a branch point of the transformation; let this point map to  $\zeta = \zeta_0$  in the  $\zeta$ -plane. For convenience, we write the potential in the  $Z$ -plane as

$$w(Z) = f(Z - Z_0),$$

then we obtain

$$\begin{aligned} W(\zeta) &= w(F(\zeta)) = f\{F(\zeta) - F(\zeta_0)\} \\ &= f\{(\zeta - \zeta_0)F'(\zeta_0) + \dots\} \text{ as } \zeta \rightarrow \zeta_0, \end{aligned}$$

which is allowed since  $F'(\zeta_0)$  exists and is non-zero (because  $\zeta = \zeta_0$  is not a branch point). Thus a singularity maps into the same type of singularity but, in general, with a change of strength (by virtue of the factor  $F'(\zeta_0)$ ). To see how this happens, consider the dipole:  $w(Z) = A/(Z - Z_0)$ , then

$$W(\zeta) = \frac{A}{(\zeta - \zeta_0)F'(\zeta_0) + \dots} \approx \frac{A/F'(\zeta_0)}{\zeta - \zeta_0} \text{ near the singularity}$$

(at  $\zeta = \zeta_0$  in the  $\zeta$ -plane); this is a dipole, but with a strength (and direction) given by  $A/F'(\zeta_0)$ .

**Comment:** An important example arises in the case of a 'log' singularity – a line vortex or source/sink – as we now show: given  $w(Z) = A \log(Z - Z_0)$ , then

$$W(\zeta) = A[(\zeta - \zeta_0)F'(\zeta_0) + \dots] \approx A \log(\zeta - \zeta_0) + \text{constant}$$

close to the singularity at  $\zeta = \zeta_0$ . Here, the additive constant is the only result of the transformation, and we already know that additive constants have no effect on potentials, so we have generated here *exactly the same singularity*.

#### (d) Complex velocities

Complex velocities in the two planes transform in the obvious way:

$$\frac{dW}{d\zeta} = \frac{dw}{dZ} F'(\zeta),$$

which are exceptional only at branch points of the transformation; this turns out to be significant in what we do later.

#### Example 33

*Transformation of a flow with a source.* A source of strength  $m$  is situated at  $\zeta = \zeta_0 = ae^{i\alpha}$  ( $0 < \alpha < \pi$ ) in the  $\zeta$ -plane, with a boundary along  $\eta = 0$  ( $-\infty < \xi < \infty$ ). Write down the complex potential for this flow. Now transform this under  $\zeta = Z^n$  to obtain a corresponding potential in the  $Z$ -plane, and interpret this in the case  $n = 2$ .

The complex potential for the flow in the  $\zeta$ -plane, obtained by using the method of images (§4.4), is

$$W(\zeta) = \frac{m}{2\pi} \log(\zeta - \zeta_0) + \frac{m}{2\pi} \log(\zeta - \bar{\zeta}_0) = \frac{m}{2\pi} \log[(\zeta - \zeta_0)(\zeta - \bar{\zeta}_0)].$$

Let  $Z_0 = (ae^{i\alpha})^{1/n}$  and introduce the transformation  $\zeta = Z^n$  to give

$$w(Z) = \frac{m}{2\pi} \log[(Z^n - Z_0^n)(Z^n - \bar{Z}_0^n)].$$

In the case  $n = 2$ , this reproduces the complex potential for a source in the first quadrant with the positive axes as boundaries (walls); see Example 28.

## Exercises 4

74. *Cauchy-Riemann relations & Laplace's equation.*

(a) Given  $w(z) = w(x + iy) = \phi(x, y) + i\psi(x, y)$ , where both  $\phi$  and  $\psi$  are real functions, construct  $\partial/\partial x$  and  $\partial/\partial y$  of this definition and hence recover the Cauchy-Riemann relations.

(b) Given Laplace's equation,  $\frac{\partial^2 w}{\partial x^2} + \frac{\partial^2 w}{\partial y^2} = 0$ , introduce the 'characteristic' variables  $z = x + iy, \bar{z} = x - iy$ , transform the equation and hence find the general solution for  $w$ . [Cf. d'Alembert's solution of the wave equation.]

75. *Laplace's equation: solution.* Use the method of separation of variables to find the solution of Laplace's equation, written in polar coordinates. Now use your result to find the solution to the problem of the symmetric flow from infinity ( $y \rightarrow +\infty$ ) approaching the solid boundary which comprises the wall  $y = 0, x > a, x < -a$ , and the semicircle  $r = a, 0 \leq \theta \leq \pi$ .

76. *Potential function & stream function.* (a) Find the velocity field represented by the stream function  $\psi = 2kxy$ , where  $k$  is a constant. Now suppose that  $\phi = k(x^2 - y^2)$  is a velocity potential (i.e. satisfies Laplace's equation) and show that it generates the same velocity field as for  $\psi$ .

(b) Find a velocity potential,  $\phi$ , which is a polynomial of degree three in  $x$  and  $y$ .



REDEFINE YOUR FUTURE  
**AXA GLOBAL  
GRADUATE PROGRAM**

redefining / standards 



77. *Dipole.* (a) Express the family of curves  $r = k \sin(\theta - \alpha)$ , where  $\alpha$  is a fixed constant and  $k$  is the parameter which generates the family, in Cartesian coordinates; hence show that each member of the family is a circle with the line  $\theta = \alpha$  as a tangent at the origin.

[Hint: use  $\sin(\theta - \alpha) = \sin \theta \cos \alpha - \cos \theta \sin \alpha$ , and then introduce  $x = r \cos \theta$ ,  $y = r \sin \theta$ .]

(b) For  $\alpha = \pi/4$ , use suitable software (e.g. MAPLE) to plot the curves  $r = k \sin(\theta - \alpha)$ ,  $0 \leq \theta \leq \pi$ , for  $k = n$  ( $n = -3, -2, \dots, 3$ ), all these 7 being on the same graph.

78. *Flow past a circle.* See Example 26; the equation for the stream function can be written (in Cartesians) as  $\psi = y(1 - 1/(x^2 + y^2))$ , where we have chosen  $U = \mu/2\pi$ . [N.B. Can you confirm this? (No need to do it!)] Use suitable software (e.g. MAPLE) to plot the streamlines  $\psi = -4, -3, \dots, 4$ , with  $-2 \leq x \leq 2$ ,  $-2 \leq y \leq 2$ , all on the same graph.

79. *Uniform flow + source.* See Example 25; write down the complex potential for a uniform stream past a source. Find the equation (expressed in polar coordinates) of the streamline which passes through the stagnation point. Then

- (a) show that one branch of this streamline is  $\theta = \pi$ ;
- (b) find  $r$  at  $\theta = \pi/2, 3\pi/2$ ;
- (c) show that  $r \sin \theta (= y) \rightarrow \pm m/2U$  as  $\theta \rightarrow 0$ .
- (d) Use suitable software (e.g. MAPLE) to plot the curves  $r = (n\pi/4 - \theta)/\sin \theta$ ,  $n = 4, 5, 8$ , for  $0.02\pi \leq \theta \leq 0.98\pi$ , all 5 on the same graph.

[This uses the choice  $m = 2\pi U$  and  $n = 4$  gives the shape of the body;  $n > 4$  then produces streamlines that represent the flow around the body. This plot generates only the upper half-plane; the lower follows by symmetry.]

80. *Complex potential from a velocity field.* A velocity field is given by

$$\mathbf{u} \equiv U \left( 1 - \frac{ay}{x^2 + y^2} + \frac{b^2(x^2 - y^2)}{(x^2 + y^2)^2}, \frac{ax}{x^2 + y^2} + \frac{2b^2xy}{(x^2 + y^2)^2} \right),$$

here  $a, b$  are constants. Find the complex potential (if one exists) and hence interpret the flow field.

81. *Flow past an ellipse.* Given the complex potential  $w(z) = U \{a'z - b'(z^2 - a^2 + b^2)^{1/2}\}$ , where  $(a', b') = (a, b)/(a - b)$  and the positive square root is chosen wherever  $z$  is real and greater than  $\sqrt{a^2 - b^2}$ , show that this represents uniform flow past the ellipse  $x = a \cos \theta, y = b \sin \theta$ . [Hint: consider the contour  $\Im(w) = 0$  and also examine the behaviour of  $w$  as  $|z| \rightarrow \infty$ .]

82. *Uniform flow past a boundary.* Given the complex potential,  $w(z)$ , such that  $w^2 = z^2 - 1$ , show that the streamline  $\psi = 1$  is the curve  $y^2(1 + x^2) = x^2$ . Hence deduce that  $w(z)$  represents a uniform flow past the object whose boundary is  $\psi = 1$ .

Use suitable software (e.g. MAPLE) to plot this shape ( $\psi = 1$ ) and the streamlines  $\psi = 0.5, 1.5, 2$ , all on the same graph, with  $-3 \leq x \leq 3, -3 \leq y \leq 3$ .

- 83. *Spinning circular cylinder.* See §4.7; find the stagnation points for the uniform flow past a spinning circle (circular cylinder) in the case  $K > 4\pi aU$ , and show that the solution requires  $\theta = 3\pi/2$  with only one solution in  $r > a$ , i.e. in the flow field, and find  $r$ .
- 84. *Source near a wall.* Use suitable software (e.g. MAPLE) to plot the streamlines for the problem of a source in the presence of a wall; see Example 27. In particular, plot the curves defined by  $x^2 - y^2 - 1 + 2nxy = 0$  for  $n = -2, -1, \dots, 2$ , with  $0 \leq x \leq 2, -3 \leq y \leq 3$ , all 5 on the same graph.
- 85. *Source + sink.* A source of strength  $m$  is placed at  $(a,0)$ , and a sink of equal strength is at  $(-a,0)$ , in a fluid which is otherwise at rest. Write down the complex potential for this flow, and show that the streamlines are circles. [Hint: introduce  $z = x + iy$  and use the method developed for Example 27.]
- 86. *Two sources + sink.* (a) Write down the complex potential for a sink of strength  $2m$  at the origin and sources each of strength  $m$  at  $(\pm a, 0)$ . Show that the streamlines of this flow field can be written in the form  $(x^2 + y^2)^2 = a^2(x^2 - y^2 + kxy)$ , where  $k$  is the constant which identifies each streamline.  
 (b) Now take the configuration in (a) and let  $a \rightarrow 0, m \rightarrow \infty$ , but such that  $a^2 m$  remains finite; find the resulting complex potential. [Cf. §4.3 for the dipole.]
- 87. *Source + sink + stream.* In a uniform stream of speed  $U$ , which moves parallel to the  $x$ -axis (in the positive  $x$ -direction), are placed a source of strength  $m$  at  $(-a,0)$  and a sink of equal strength at  $(a,0)$ . Write down the complex potential for this flow and find the positions of all the stagnation points.

Now find a general expression for the streamlines and hence show that the streamline which has  $y = 0$  as one branch can be written as

$$(x^2 + y^2 - a^2) \tan(2\pi yU/m) = 2ay.$$

- 88. *Three vortices.* Two line vortices, each of strength  $K$ , are situated at  $(\pm a, 0)$ , and another, of strength  $-\frac{1}{2}K$ , is placed at the origin. Show that the fluid at infinity is stationary, and also find the positions of the two stagnation points. Find an equation for the streamlines, and hence show that the streamline which passes through the stagnation points meets the  $x$ -axis at  $(\pm b, 0)$ , where  $b$  is a solution of

$$3\sqrt{3}(b^2 - a^2)^2 = 16a^3b.$$

- 89. *Two sources + two sinks.* Two sources are placed at  $(\pm a, 0)$ , and two sinks are placed at  $(0, \pm a)$ , all four being of equal strength. Show that one streamline is the circle which passes through all four points.

**90. Method of Images I.** In these two-dimensional flows, a source of strength  $m$ , and a sink of equal strength, are positioned as below; in all cases  $a > 0$  (real). The boundary to the flow, and the region of the flow, is given. In each case, use the method of images to write down the complex potential for the flow and find the velocity components at the point requested. Also provide a rough sketch of the flow field in the region where the flow exists.

- (a) Source at  $z = ia$  and sink at  $z = 2ia$ ; boundary is  $y = 0$  and the flow is in  $y \geq 0$ ; find the velocity components at  $z = a$ .
- (b) Source at  $z = 2a$  and sink at  $z = a + ia$ ; boundary is  $x = 0$  and the flow is in  $x \geq 0$ ; find the velocity components at  $z = 0$ .
- (c) Source at  $z = a$  and sink at  $z = 2a + ia$ ; boundary is  $x = 0$  and the flow is in  $x \geq 0$ ; find the velocity components at  $z = 0$ .
- (d) Source at  $z = ia$  and sink at  $z = a + ia$ ; boundary is  $y = 0$  and the flow is in  $y \geq 0$ ; find the velocity components at  $z = 0$ .

**91. Method of Images II - source.** A source of strength  $m$  is situated at the point  $(a,0)$ , with  $a > 0$ , in a fluid which occupies the region  $x > 0, -\infty < y < \infty$ , where the axis  $x = 0$  is a solid boundary. Show that the equation of the streamlines is  $x^2 + \lambda xy - y^2 = a^2$ , where  $\lambda$  is the constant parameter which describes the streamline.

**92. Method of Images III - source.** Write down the complex potential for the flow which is generated by a source of strength  $m$  located at  $(a,0)$ , with  $a > 0$ , where the lines  $y = \pm x, x \geq 0$ , are solid boundaries. Give a rough sketch of the streamlines.

**93. Method of Images IV - source.** Write down the complex potential for the flow which is generated by a source of strength  $m$  at the point  $z = ae^{i\alpha}$ , where  $0 < \alpha < \pi/3$ , and where  $z = r, z = re^{i\pi/3}$  are solid boundaries. [Hint: look for six-fold symmetry.]

**94. Method of Images V - source/sink.** A source of strength  $m$  is situated at  $(a,b)$ , and a sink of equal strength is at  $(a,-b)$ , in a flow field which is restricted to the region  $x > 0$ ; both  $a$  and  $b$  are positive and the axis  $x = 0$  is a solid boundary. Obtain the complex potential for this flow and hence derive the equation for the streamlines. Confirm from your equation that  $x = 0$  is indeed a streamline, and show that another branch of the same streamline is a circle.

**95. Method of Images VI - source/sink.** A source of strength  $m$  is located at  $(-2a, b)$ , and there is a sink of equal strength at  $(2a, b)$ , where both  $a$  and  $b$  are positive. Find the equation which describes the streamlines for this flow and show that they are circles of radius  $\sqrt{4a^2 + (\lambda - b)^2}$ , centre  $(0, \lambda)$ , where  $\lambda$  is the constant parameter which identifies the streamline; cf. Ex. 85. Find the speed of the flow at the origin.

A flow is generated in exactly the same fashion, but now in the presence of a solid boundary: the axis  $y = 0$ , and the flow is restricted to the half-plane  $y > 0$ . Directly from the appropriate complex potential, deduce the speed of this new flow at the origin, and show that it is twice that obtained in the absence of the boundary.

**96. Method of Images VII - vortex.** A line vortex of strength  $K$  is located at  $z = ib$  (where  $b > 0$ ) and the axis  $y = 0$  is a solid boundary; the flow is restricted to the region  $y > 0$ . Find the complex potential for the resulting flow. [Hint: take care - mirror image!] Give a rough sketch of the streamlines.

97. *Method of Images VIII - vortex.* A line vortex of strength  $K$  is placed at  $z = ae^{i\alpha}$  ( $0 < \alpha < \pi/2$ ), with solid boundaries along  $z = r$ ,  $z = re^{i\pi/2}$ . Find the complex potential which describes the flow field in  $x > 0, y > 0$ .
98. *Method of Images IX - vortex.* A line vortex of strength  $K$  is located at  $(a,0)$ , where  $a > 0$  and  $x = 0$  is a solid boundary; the flow is restricted to the half-plane  $x > 0$ . Obtain the equation for the streamlines of this flow and show that the streamline which passes through the point  $(\mu a, 0)$  also passes through  $(a/\mu, 0)$ , where  $0 < \mu < 1$ .
99. *Method of Images X - moving vortex.* See Ex. 97; now find the complex velocity that describes the motion of the vortex (i.e. ignoring the singularity associated with the vortex; cf. Example 22). Write this complex velocity as  $dw/dz = \dot{X} - i\dot{Y}$  (where the dot denotes the derivative with respect to time) and hence deduce that the path of the (moving) vortex is given by  $dY/dX = -Y^3/X^3$ . Hence obtain the family of paths  $X^{-2} + Y^{-2} = \text{constant}$ , and sketch a typical path. [Note: The vortex is at  $z = ae^{i\alpha}$  only at  $t = 0$ .]
100. *Elements of the Circle Theorem.* For the following functions,  $f(z)$ , write down  $\bar{f}(z)$  and  $\bar{f}(a^2/z)$  where  $U, a, b$  and  $\alpha$  are real :
- (a)  $Ue^{-i\alpha}z$ ; (b)  $\log z$ ; (c)  $\log(z - ia)$ ; (d)  $i \log(z - ia)$ ; (e)  $e^{i\alpha}/(z - a - ib)$ .
101. *Simple conformal transformation.* Given the conformal transformation  $\zeta = 1/z$  ( $z \neq 0$ ) show that (a) the region interior to  $|z| = 1$  maps into the exterior of  $|\zeta| = 1$  and (b) find into what the circle  $|z| = 1$  maps. Then find the result of applying the mapping to : (c) the circle of radius  $b$  ( $\neq a$ ), centre at  $z = ae^{i\alpha}$ ; (d) the circle of radius  $a$ , centre  $z = ae^{i\alpha}$ .

I'm with ZF.  
Engineer and Easy Rider.

I enjoy motorcycle riding as a hobby. My mind is free and clear. I just feel great. Especially in this famous region where I live and work. Riding on the legendary Blue Ridge Parkway with its beautiful scenic views is breath-taking. I have a great life and a great job. The doors are always open and everybody helps each other out. My name is Charles Jenkins and I'm working as a quality engineer. For more about me, what I do, and why I really enjoy working at ZF, go to [www.im-with-zf.com](http://www.im-with-zf.com).

**Driveline and Chassis Technology**

Charles Jenkins  
Quality Engineer  
ZF Friedrichshafen AG  
North Carolina USA

[www.im-with-zf.com](http://www.im-with-zf.com)



102. *Forces & moment.* The complex velocity for a flow is written as the Laurent expansion  $\frac{dw}{dz} = U + \sum_{n=1}^{\infty} a_n z^{-n}$ , where  $a_n$  are complex constants and  $U$  is a real constant. Find the moment (about the origin) of the forces which are exerted on a contour which encloses  $z = 0$ . Now apply your result to the uniform flow about a spinning cylinder.
103. *Forces I.* Write down the complex potential,  $w(z)$ , for the flow about the circular cylinder  $|z| = a$ , produced by a source of strength  $m$  at  $z = 2a$ . Show that :
- (a) the force on the cylinder is  $\rho m^2 / 12\pi a$  (per unit length), and find its direction;
- (b)  $\oint_C (dw/dz)^2 dz = 0$  where  $C$  is the contour  $|z| = 3a$ , and hence deduce the force on the source.
104. *Forces II.* See Ex. 103; now find the force on the cylinder when the source is at the general point  $z = na$  ( $n > 1$ ).
105. *Forces III.* Write down the complex potential for the flow about the circular cylinder  $|z| = a$ , generated by a source of strength  $m$  at  $(0, 2a)$  and a second source, of strength  $2m$ , at  $(2a, 0)$ . Find the components of the force exerted by the flow on the cylinder.
106. *Forces IV.* Write down the complex potential for the flow past the circular cylinder  $|z| = a$ , produced by a source of strength  $m$  at  $(2a, 0)$  and a second source, of strength  $km$  at  $(-3a, 0)$ . Find the force exerted by the flow on the cylinder, and show that this is zero if  $k = \frac{2}{7}(-1 \pm 5\sqrt{2})$ .
107. *Uniform flow past a boundary.* A uniform flow (speed  $U$  parallel to the  $x$ -axis) past the circle  $|z| = c$  is transformed according to  $z = \zeta + a^2/\zeta$ ; show that the resulting potential in the  $\zeta$ -plane relates to the same flow past a branch of the curve

$$(x^2 + y^2)(x^2 + y^2 - c^2) + 2a^2(x^2 - y^2) + a^4 = 0.$$

\*\*\*\*\*

# 5 Aerofoil Theory

In this final chapter, we collect together all the ideas and techniques that we have developed – including the nature of viscous flow – and apply them to an introductory discussion of *aerofoil theory*. In particular, we introduce a simple conformal transformation that generates a class of aerofoil shapes from circles; this is then applied to uniform flow past a circle (and the same flow past an aerofoil), enabling us to provide a very simple explanation of, and a formula for, the lift generated by the aerofoil.

In 1910 – and this should be compared with 17 December 1903, the first flight by the Wright brothers – a Russian mathematician, N.E. Joukowski (sometimes transliterated as Zhukovsky) discovered a simple, but powerful, conformal transformation. [N.E. Joukowski, 1847-1921; taught analytical mechanics at Moscow University from 1874; made contributions to many branches of mechanics; developed the theory of the gyroscope.] This produces aerofoils from circles, and otherwise has all the properties that we might expect and hope of a transformation that is of practical use. The philosophy that we adopt is then:

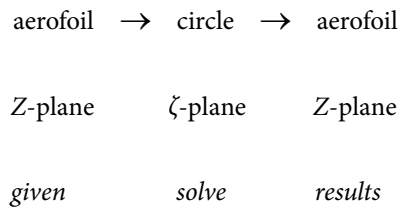

but, because we shall be able to confirm that the transformation is conformal and one-to-one, as required, and we already know how to formulate and solve the problem for flow past a circle, it is usual to work with only the last two stages here. That is, we set-up a suitable problem of flow past a circle (in the  $\zeta$ -plane), determine the flow characteristics that are relevant, and then map this to the *Z*-plane that contains the aerofoil that we wish to study.

The *Joukowski transformation* (JT) is

$$Z = \zeta + \frac{a^2}{\zeta} \quad (a \text{ real with } a > 0);$$

so

$$\zeta^2 - Z\zeta + a^2 = 0 \quad \text{or} \quad (\zeta - \frac{1}{2}Z)^2 = \frac{1}{4}Z^2 - a^2$$

i.e.

$$\zeta = \frac{1}{2} \left( Z \pm \sqrt{Z^2 - 4a^2} \right).$$

Clearly, from the definition of the JT, we have  $Z \approx \zeta$  for  $|\zeta| \rightarrow \infty$ , but we must be able to map back again i.e. we require a one-to-one mapping. (Note that this condition ensures that the flow at infinity, in the two planes, will be identical.) Now  $\zeta \approx Z$ , as  $|Z| \rightarrow \infty$ , only if we select the positive sign above; thus we regard the JT, in its entirety, as

$$\left. \begin{aligned} Z &= \zeta + \frac{a^2}{\zeta} \\ \zeta &= \frac{1}{2} \left( Z + \sqrt{Z^2 - 4a^2} \right) \end{aligned} \right\} \text{mapping points outside and on.}$$

Finally, we observe that the JT,  $Z = F(\zeta) = \zeta + \frac{a^2}{\zeta}$ , has  $F'(\zeta) = 1 - \frac{a^2}{\zeta^2}$ ;

thus we have branch (critical) points of the transformation at  $\zeta = 0$  and  $\zeta = \pm a$ . (The first point is where the derivative is undefined, and the next two are where it is zero.) We now investigate what happens to various circles, in the  $\zeta$ -plane, which are mapped to the  $Z$ -plane under the JT.

### 5.1 Transformation of circles

The  $\zeta$ -plane contains the circle, whose position is carefully chosen, particularly with regard to the positions of the branch points. It will soon be evident that the branch point at the origin is irrelevant: it will always lie inside the circle (and points inside are not mapped); the other two may be on the circle, or inside, but never outside.

(a) Circle  $|\zeta| = b (> a)$

We set  $\zeta = be^{i\theta}$ , and then  $0 \leq \theta \leq 2\pi$  maps out the circle; the JT therefore gives

$$Z = be^{i\theta} + \frac{a^2}{b}e^{-i\theta} = \left( b + \frac{a^2}{b} \right) \cos \theta + i \left( b - \frac{a^2}{b} \right) \sin \theta,$$

and so

$$x = \left( b + \frac{a^2}{b} \right) \cos \theta, \quad y = \left( b - \frac{a^2}{b} \right) \sin \theta,$$

which is the parametric representation of an ellipse (with semi-axes  $b + a^2/b$  and  $b - a^2/b$ ). Thus the circle, which encloses all three branch points, maps into an ellipse (which encircles the points  $2a$  and  $-2a$  into which the branch points map):

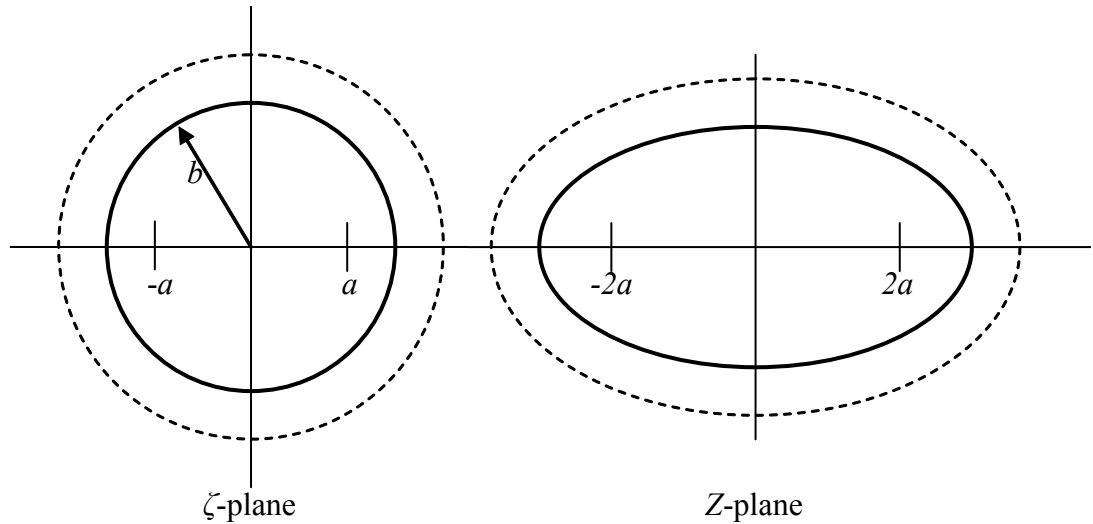

The solid lines show the circle and the ellipse, and we note that the resulting curve is smooth: it is conformal everywhere. If we select points exterior to the circle – and the dotted circle selects just such a set – then these map to points exterior to the ellipse (the dotted ellipse). Thus the region occupied by the boundary of the circle and its exterior map to the boundary of the ellipse and its exterior; points inside the circle are not mapped. [It is left as an elementary exercise to confirm that, indeed, the ellipse encircles the points  $Z = \pm 2a$  i.e.  $b + a^2/b > 2a$  for  $b > a$ .]

(b) Circle  $|\zeta| = a$

This time the circle *passes through* the two branch points at  $\zeta = \pm a$ ; we set  $\zeta = ae^{i\theta}$ , and so

$$Z = ae^{i\theta} + ae^{-i\theta} = 2a \cos \theta;$$

this is a flat plate positioned on the real axis (from  $-2a$  to  $2a$ ). Points exterior to the circle follow the discussion above: they map to points exterior to the plate (the dotted curves below):

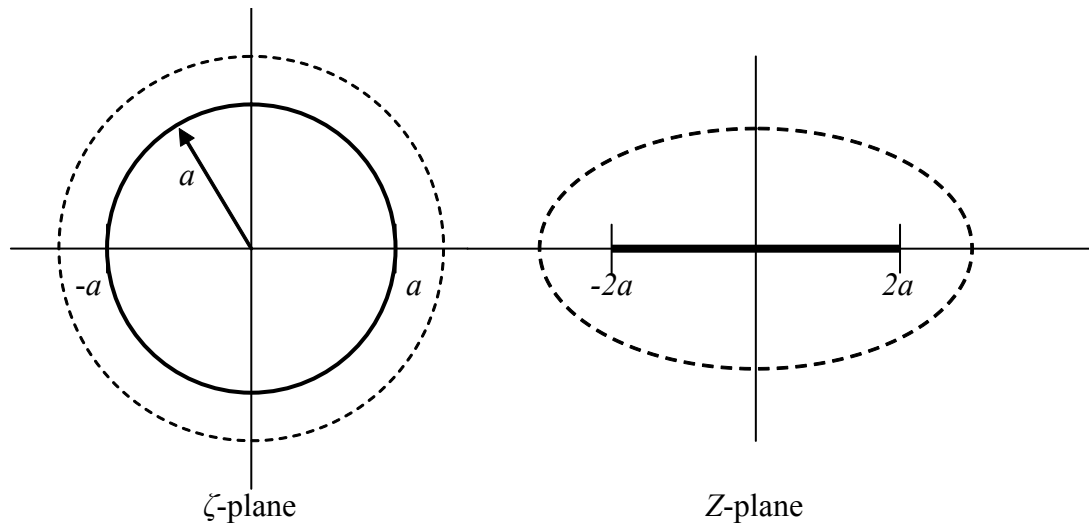

At Navigant, there is no limit to the impact you can have. As you envision your future and all the wonderful rewards your exceptional talents will bring, we offer this simple guiding principle: It's not what we do. It's how we do it.

**Impact matters.**

**NAVIGANT**  
navigant.com

DISPUTES & INVESTIGATIONS • ECONOMICS • FINANCIAL ADVISORY • MANAGEMENT CONSULTING

©2013 Navigant Consulting, Inc. All rights reserved. Navigant Consulting is not a certified public accounting firm and does not provide audit, attest, or public accounting services.  
See [navigant.com/licensing](http://navigant.com/licensing) for a complete listing of private investigator licenses.



This description of these exterior points enables us to identify points above and below the (infinitesimally thin) plate. Consider the circle exterior to  $|\zeta| = a$ , and allow its radius to approach  $a$ ; this corresponds to an ellipse which approaches the flat plate in the  $Z$ -plane. For  $0 < \theta < \pi$  on the circle in the  $\zeta$ -plane, the corresponding points in the  $Z$ -plane are just above the plate; for  $\pi < \theta < 2\pi$ , they are just below. Also note that the plate is flat, so everywhere along its surface, conformality occurs – but *conformality fails* at the front and back (called the *leading* and *trailing edges*), where  $\theta = 0, \pi$  (i.e.  $\zeta = \pm a$ ): the branch points.

**Note:** If we allow  $b \rightarrow a$  in case (a), then we recover the flat plate, although the curvature changes dramatically at  $\theta = 0, \pi$  as the limit is completed.

(c) Circle  $|\zeta - ik| = r$  for  $k > 0$  (real) and  $r^2 = a^2 + k^2$

This circle also passes through the two branch points at  $\zeta = \pm a$ , but its centre is moved up the imaginary axis, to  $\zeta = ik$ . Here, we set  $\zeta = ik + re^{i\theta}$  to give

$$Z = ik + re^{i\theta} + \frac{a^2}{ik + re^{i\theta}} = ik + re^{i\theta} + \frac{a^2}{ik + re^{i\theta}} \frac{-ik + re^{-i\theta}}{-ik + re^{-i\theta}},$$

where, in the second term, we have multiplied top-and-bottom by the conjugate. This then becomes

$$Z = ik + r(\cos \theta + i \sin \theta) + \frac{a^2(-ik + r \cos \theta - ir \sin \theta)}{(r \cos \theta)^2 + (k + r \sin \theta)^2}$$

which eventually gives – the details are unimportant in the analysis as presented here – the parametric form of the resulting curve in the  $Z$ -plane:

$$x = \frac{2r^2(r + k \sin \theta) \cos \theta}{r^2 + k^2 + 2kr \sin \theta}, \quad y = \frac{2k(k + r \sin \theta)^2}{r^2 + k^2 + 2kr \sin \theta}.$$

The curve represented by these expressions turns out to be the arc of a circle, but the upper and lower surfaces – interpreted as such, following our discussion of the flat plate – are not mapped symmetrically. The upper surface is mapped out as  $\theta$  goes from  $\zeta = a$  to  $\zeta = -a$  along the upper arc of the circle in the  $\zeta$ -plane; the lower arc of the circle – the same shape! – in the  $Z$ -plane is recovered as  $\theta$  goes from  $\zeta = -a$  to  $\zeta = a$  along the lower arc in the  $\zeta$ -plane. (This explains the complicated structure of the parametric form for what is, apparently, a simple curve.) This is evident in the figure:

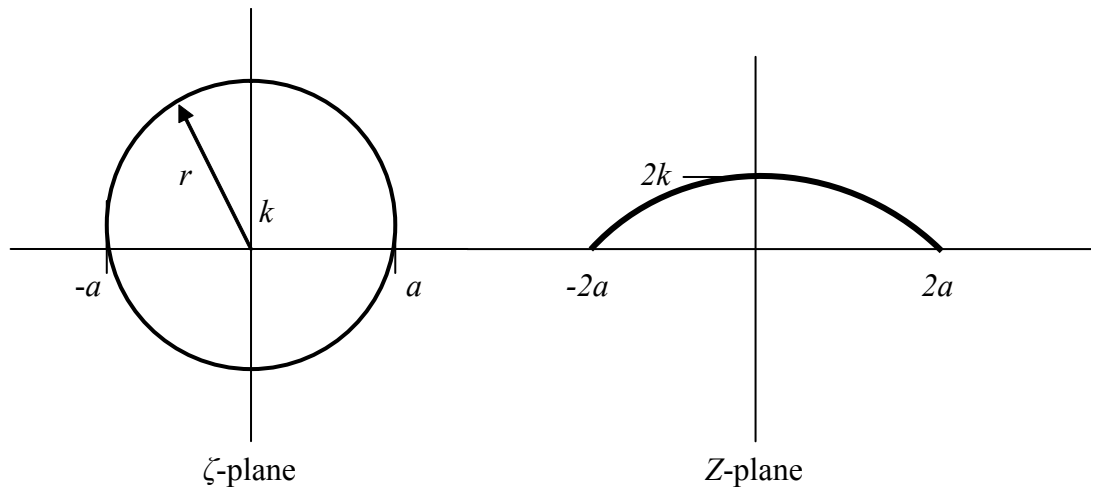

The radius of the circle, whose arc is generated in the  $Z$ -plane, is  $k + a/k$  and the intercept on the imaginary ( $y$ -axis) is at  $y = 2k$ . Like the flat plate, it is smooth – so conformality is evident – along the arc, but conformality fails at the two end points (corresponding to  $\zeta = \pm a$ , the branch points in the  $\zeta$ -plane). This is called the *cambered plate*; it was the shape chosen by the Wright brothers for their Wright Flyer I – its lift-generation is far better than for a simple flat plate (which *does* generate lift, but not as much).

(d) Circle  $|\zeta - a + r| = r$  ( $> a$ )

This time, the circle has its centre moved along the real axis (to  $\zeta = a - r$  ( $< 0$ )), but with a radius chosen so that the circle passes through the branch point at  $\zeta = a$ ; the choice otherwise ensures that the circle encloses the other branch point at  $\zeta = -a$ . We set  $\zeta = a - r + re^{i\theta}$  and then the calculation follows those described earlier; the result – the details are again unimportant – is:

$$x = a - r + r \cos \theta + \frac{a^2(a - r + r \cos \theta)}{(a - r + r \cos \theta)^2 + (r \sin \theta)^2},$$

$$y = r \sin \theta - \frac{a^2 r \sin \theta}{(a - r + r \cos \theta)^2 + (r \sin \theta)^2},$$

providing the figures:

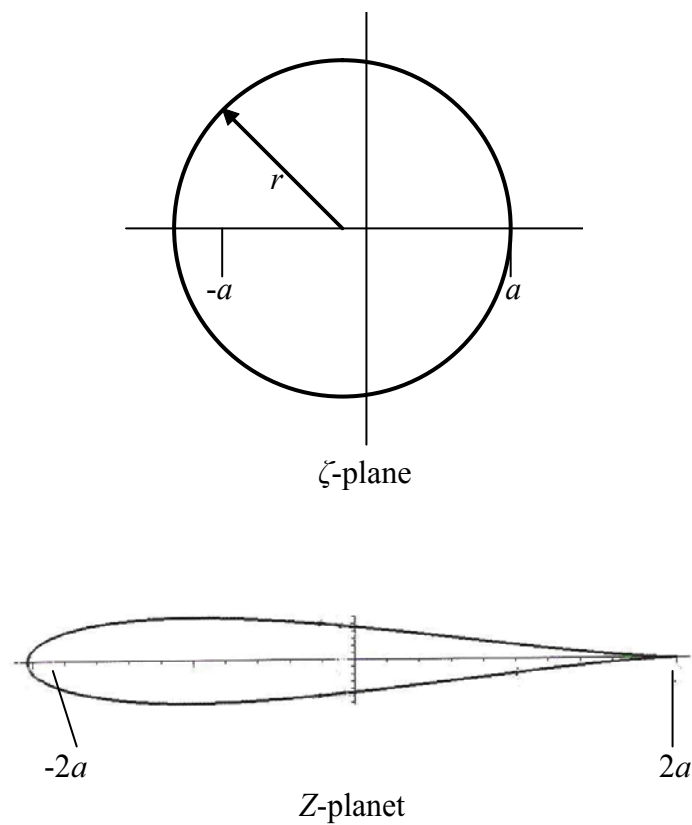

Success here is about overcoming challenges – especially the ones we didn't even think of. I look forward to that.

- Scott, Mechanical Engineering Group Leader

**Collaborating. Inspiring. Leading.**

Monsanto has always embraced innovation and always focused on helping to make a better world. You can see it in our groundbreaking products and in our dynamic environment where your skills and your career can grow and develop. We know that every day, new ideas can come from anyone, anywhere. At Monsanto, you'll be respected, you'll contribute to the bottom line and you'll help farmers feed the world.

**Start right now: [www.monsanto.com/students](http://www.monsanto.com/students)**

ERO/AA EMPLOYER M/1/14V ©2013 Monsanto Company

**MONSANTO** 



This is a *symmetric aerofoil*, for which the *leading edge* – to the left – is round-nosed, and the *trailing edge* – to the right – is sharp; indeed, the shape at the trailing edge is a *cusps*. This aerofoil shape satisfies conformality everywhere, except at the trailing edge; this is consistent with the original circle, which encloses one branch point (cf. the shape of the ellipse in (a)) and passes through the other (cf. the flat plate and the cambered plate).

(e) General Joukowski aerofoil

We now combine all the ideas exhibited in the previous examples. We select a circle, in the  $\zeta$ -plane, which encloses the branch point at  $\zeta = -a$  (resulting in a round nose), which passes through the branch point at  $\zeta = a$  (producing a sharp trailing edge) and which has a centre moved into  $y > 0$  (see (c)) giving a bend (camber) to the aerofoil. Thus the circle is

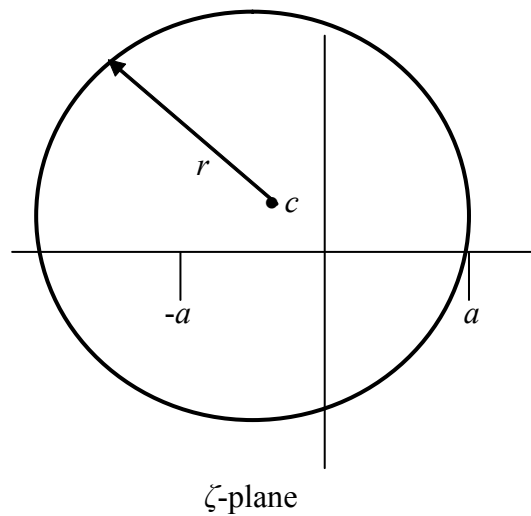

which has a centre at  $\zeta = c$ , where  $c$  is a suitable complex number. The resulting general Joukowski aerofoil is then

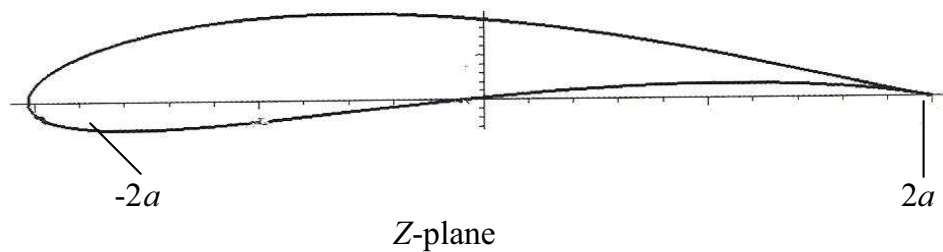

Other examples of Joukowski aerofoils are shown in Appendix 5.

## 5.2 The flat-plate aerofoil

The problem that we formulate here is the simplest one under the umbrella of aerofoil theory, in the context of the Joukowski transform: uniform flow past a flat plate. To accomplish this, we first consider the problem of a general uniform flow (speed  $U$ , angle of incidence  $\alpha$ ) past a circle in the  $\zeta$ -plane; the circle is to be of radius  $a$ , so that the flat plate is obtained in the  $Z$ -plane. This problem comprises elements that have already been discussed: uniform flow past a circle (§4.6) and the transformation to produce a flat plate (§5.1(b)). Because we are familiar with the appropriate problem that we need to formulate in the  $\zeta$ -plane, it is unnecessary, formally, to start with the  $Z$ -plane, map to the  $\zeta$ -plane and then back again: we shall start in the  $\zeta$ -plane and then simply map to the  $Z$ -plane.

Thus, in the  $\zeta$ -plane, we have the flow (see §4.5, 4.6) past a circle, which is placed at the origin, with the flow direction given by  $\alpha$  which, in the context of aerofoil theory, is called the *angle of incidence*:

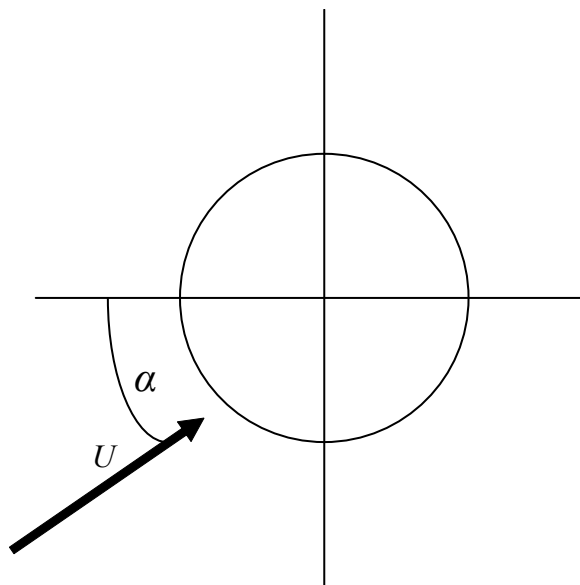

The complex potential is

$$W(\zeta) = Ue^{-i\alpha}\zeta + Ue^{i\alpha}\frac{a^2}{\zeta},$$

obtained, for example, by invoking the Milne-Thomson circle theorem; this circle is of radius  $a$ , ensuring that a flat plate is generated in the  $Z$ -plane. This potential is now transformed, according to

$$\zeta = \frac{1}{2}\left(Z + \sqrt{Z^2 - 4a^2}\right),$$

to produce the corresponding potential,  $w(Z) = W(\zeta(Z))$ , for the flow in the  $Z$ -plane which, we know, contains the plate. (Remember that we map only those points outside and on the circle i.e. for  $|\zeta| \geq a$ .) It is convenient to write the complex potential as

$$W(\zeta) = U \left\{ (\cos \alpha - i \sin \alpha) \zeta + (\cos \alpha + i \sin \alpha) \frac{a^2}{\zeta} \right\}$$

$$= U \left\{ \left( \zeta + \frac{a^2}{\zeta} \right) \cos \alpha - i \left( \zeta - \frac{a^2}{\zeta} \right) \sin \alpha \right\},$$

and then, in the first bracketed term, we use  $Z = \zeta + a^2/\zeta$ ; in the second term we use

$$\zeta = \frac{1}{2} \left( Z + \sqrt{Z^2 - 4a^2} \right) \text{ written in the form } 2\zeta - Z = \sqrt{Z^2 - 4a^2},$$

with  $\zeta - a^2/\zeta = \zeta - (Z - \zeta) = 2\zeta - Z$ . Thus the potential for the flow in the  $Z$ -plane becomes

$$w(Z) = U \left\{ Z \cos \alpha - i \sqrt{Z^2 - 4a^2} \sin \alpha \right\};$$

we note that, for  $|Z| \rightarrow \infty$ , we obtain  $w(Z) \approx U(\cos \alpha - i \sin \alpha)Z$  which is the same uniform flow at infinity as in the  $\zeta$ -plane – exactly as expected for this transform.



Are you the surfer or the wave?

Creating the future of communications technology requires to be a powerful force for change and at the same time be swift and agile enough to deliver even in varying conditions. Which is why when you look at our history of innovation you'll find countless awards and even a handful of Nobel Prizes in our company résumé. And when you look at our teams, you will find dynamic, diverse, passionate professionals. Hand-in-hand, team by team, every day we bring innovations to market to help realize the potential of a connected world.

..... Alcatel·Lucent 

[www.alcatel-lucent.com/careers](http://www.alcatel-lucent.com/careers)



Although we could find, for example, the streamlines for this flow – not quite routine, but possible – it is more enlightening to construct the complex velocity, and then evaluate this on the plate. Thus we have

$$\frac{dw}{dZ} = U \cos \alpha - i \frac{Z}{\sqrt{Z^2 - 4a^2}} U \sin \alpha,$$

which, we note, is defined everywhere away from  $Z = \pm 2a$ ; on the flat plate where  $Z = 2 \cos \theta$  (where  $\theta$  takes us around the plate; see §5.1(b)) we obtain

$$\frac{dw}{dZ} = u - iv = U \cos \alpha - U \sin \alpha \cot \theta.$$

This expression is pure real i.e. there is no component of the velocity *through* the plate: the plate is a streamline. However, the  $x$ -component of the velocity is undefined at  $\theta = 0, \pi$  i.e. at the leading and trailing edges of this flat-plate aerofoil. Also, at  $\theta = \alpha, \pi + \alpha$ , we have  $u = 0$ ; these two points – one on the upper surface and one on the lower surface – are therefore stagnation points of the flow. The resulting flow, represented by the streamlines, is

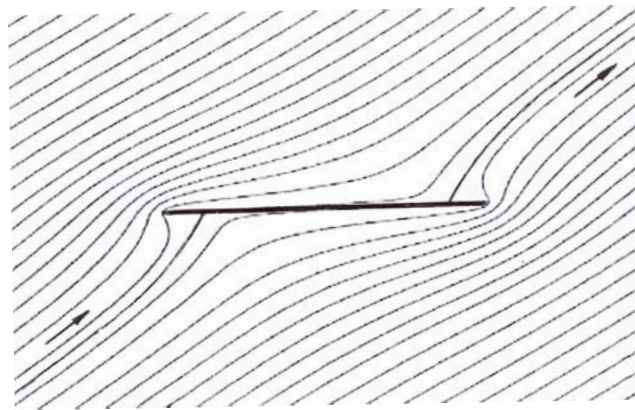

and the two aspects of the flow just mentioned are clear. The infinite speeds at the ends of the plate are evident by the flow having to accelerate around the infinitesimally thin plate, and the two stagnation points are also obvious.

The flow is clearly symmetric above and below (but reversed); consequently, whatever the pressure distribution is on top, it is repeated (in reverse) on the bottom: there can be no lift generated by this flow pattern past the plate. Indeed, by the Kutta-Joukowski theorem (Example 31), we know that the lift is zero: in this flow field there is no circulation ( $K = 0$ ). (The anti-symmetry does produce a moment about the centre of the plate, tending to pitch it upwards at the front; more of this later.) So what can we do to generate lift?

The flow past a flat plate (with the angle of incidence,  $\alpha$ , not too large – say not more than about  $10^\circ$ ), as observed in the laboratory, looks rather different; typically, it has the following form:

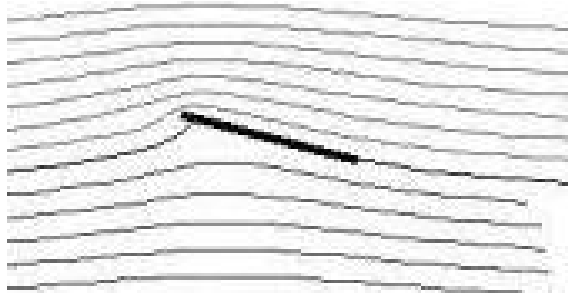

This flow has a number of important differences as compared with the theoretical prediction described above. Although there is a stagnation point on the lower surface, there is not one on the upper surface. Also, although there is still a high speed of the flow around the front of the plate – high, but not infinite, because a real plate has a non-zero thickness and a non-zero radius of curvature at the leading edge – the flow at the trailing edge leaves smoothly and with a speed not far different from the free-stream speed. This phenomenon can be interpreted like this: the stagnation point that was on the upper surface moves to the trailing edge and nullifies the infinite speed that was there. (Clearly, the symmetry – reversed – on the upper and lower surfaces is no longer evident, so perhaps we will get lift this time.) How has this change come about?

It is the property of viscosity in a real fluid that produces the flow field that is observed in the laboratory. The flow on the upper surface, by virtue of the viscous forces, remains attached to that surface, allowing the flow to leave the trailing edge smoothly. The effect of viscosity is, therefore, to take the inviscid (ideal) flow and induce a rotation in it, to the extent that the stagnation point on the upper surface is moved towards the trailing edge of the plate; this is precisely the effect that circulation would generate. (There is NOT a corresponding forward movement of the lower stagnation point, leading to a cancellation of the infinite speed there. Remember what happened to the spinning circle (see §4.7): both stagnation points moved downwards (and *downwards* is towards the trailing edge on top, in the geometry of the plate, and away from the leading edge on the bottom).) The general phenomenon of fluid sticking to a surface is well-known. Consider what happens when pouring a liquid out of a jug; a poorly-designed lip causes the liquid to dribble over and down the outside of the jug; the fluid wants to stick to the surface of the jug. A good design forces the liquid to make a clean break at the lip, and pour away from the surface. This adhesive property of a real fluid is usually called the *Coanda effect* (after the Romanian aerodynamicist H.-M. Coanda, 1885-1972, who investigated this property of fluids, and designed many devices that use this phenomenon). It can happen that the flow over the wing does not remain attached; this occurs when the wing stalls. The boundary layer, which is always present in the flow of a viscous fluid, gets pulled away from the surface (due to adverse pressure gradients), causing a very turbulent region to appear behind the aerofoil, involving eddies and vortex shedding, and resulting in a very significant loss in the lift force:

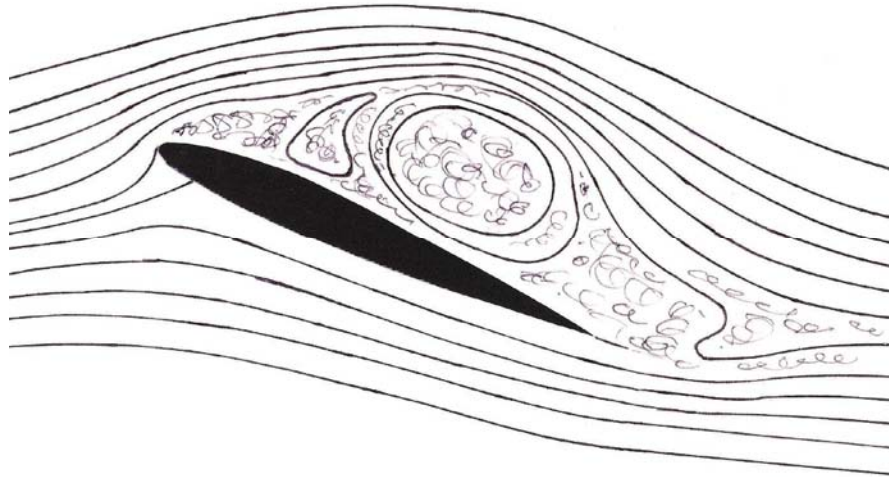

The viscous forces, therefore, are fundamental in the realisation of these flow fields (and, as we shall see, these flows DO produce lift on the aerofoils). However, because the Reynolds numbers are so high, the effects on the flow are otherwise negligible – if we ignore the generation of drag! The boundary layers are very thin indeed – about  $1/10,000^{\text{th}}$  of the length of the wing section from leading to trailing edge (usually called the *chord* of the wing) – and so the flow is barely distorted; it is essentially inviscid away from the surface of the wing.

## Budget-Friendly. Knowledge-Rich.

The Agilent InfiniiVision X-Series and 1000 Series offer affordable oscilloscopes for your labs. Plus resources such as lab guides, experiments, and more, to help enrich your curriculum and make your job easier.



Scan for free Agilent iPhone Apps or visit [qrs.ly/po20pli](http://qrs.ly/po20pli)





**See what Agilent can do for you.**  
[www.agilent.com/find/EducationKit](http://www.agilent.com/find/EducationKit)

© Agilent Technologies, Inc. 2012 u.s. 1-800-829-4444    canada: 1-877-894-4414

Anticipate — Accelerate — Achieve

**Agilent Technologies**



So we now address the problem of modelling a flow which, although generated by the presence of viscosity, is essentially inviscid. The method is to introduce the circulation that the viscous forces induce in the flow field around the aerofoil; by virtue of the Kutta-Joukowski theorem, we may thus expect that lift is generated. (As we have just indicated, although we shall be able to describe lift – surprisingly accurately – the neglect of viscosity will mean that we cannot predict the drag on the aerofoil.)

### 5.3 The flat-plate aerofoil with circulation

We now consider the uniform flow past a circle, with circulation, in the  $\zeta$ -plane; the potential for this follows directly from our discussion in §4.7:

$$W(\zeta) = Ue^{-i\alpha}\zeta + Ue^{i\alpha}\frac{a^2}{\zeta} + i\frac{K}{2\pi}\log\zeta,$$

where the circle, centred at the origin, is of radius  $a$  (so that we generate the flat plate), and the circulation is *clockwise* of magnitude  $K$ . When we remember that a log singularity generates the *same* singularity under a conformal transformation (and points inside the circle are not mapped), we can represent the two flow fields schematically as:

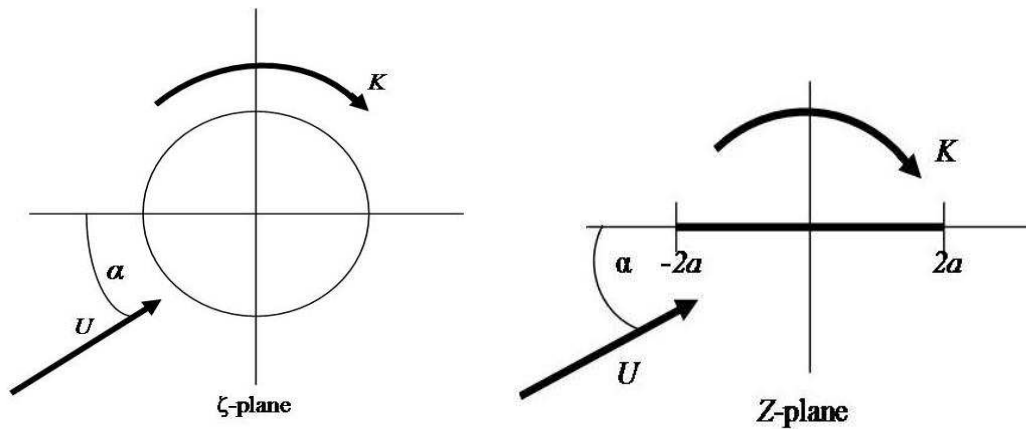

We have seen that the most useful information is provided by the velocity field, so we find

$$\frac{dw}{dZ} = \frac{dW}{d\zeta} \frac{d\zeta}{dZ} = \frac{U\left(e^{-i\alpha} - e^{i\alpha}\frac{a^2}{\zeta^2}\right) + i\frac{K}{2\pi}\frac{1}{\zeta}}{1 - a^2/\zeta^2} \Bigg|_{\zeta=\zeta(Z)}$$

and it is convenient to multiply this by  $\zeta/\zeta$  to give

$$\frac{dw}{dZ} = \frac{U \left( e^{-i\alpha} \zeta - e^{i\alpha} \frac{a^2}{\zeta} \right) + i \frac{K}{2\pi}}{\zeta - a^2/\zeta} \Bigg|_{\zeta=\zeta(Z)}$$

The plate corresponds to the evaluation  $\zeta = ae^{i\theta}$ , and then  $\theta$  takes us around the plate, and we have seen that the velocities on the plate are the most revealing aspect of the velocity field. So we examine

$$\begin{aligned} \frac{dw}{dZ} \Big|_{\text{plate}} &= \frac{Ua \left( e^{i(\theta-\alpha)} - e^{-i(\theta-\alpha)} \right) + iK/2\pi}{a \left( e^{i\theta} - e^{-i\theta} \right)} \\ &= \frac{2aU \sin(\theta - \alpha) + K/2\pi}{2a \sin \theta} \end{aligned}$$

which is pure real (as before and as expected). At this stage we have not chosen  $K$ ; we do this by imposing the condition that  $w'(Z)$ , as the trailing edge ( $\theta = 0$ ) is approached, remains finite. This is called the *Kutta condition* (introduced by Kutta in 1902). [M.W. Kutta, 1867-1944, German mathematician; Lilienthal (and the Wright brothers) thought that curved surfaces were better than flat ones for producing lift; Kutta worked on this problem from about 1902.] Here,  $w'(Z)$  can remain finite as  $\theta \rightarrow 0$  only if

$$-2aU \sin \alpha + \frac{K}{2\pi} = 0$$

for the denominator is zero in this limit. (This does not *guarantee* that the limit is finite, but the only possibility of obtaining a finite limit is for the numerator to be zero on  $\theta = 0$ ; the nature of this limit will be discussed below.) Thus we choose

$$K = 4\pi aU \sin \alpha,$$

which selects the circulation in terms of the free-stream speed ( $U$ ) and the geometry ( $a$  and  $\alpha$ ).

**Check:** We calculate the limit, with the choice of  $K$  above:

$$\begin{aligned} w'(Z)|_{\text{plate}} &= \frac{U(\sin \theta \cos \alpha - \cos \theta \sin \alpha) + K/4\pi a}{\sin \theta} \\ &= \frac{U \sin \theta \cos \alpha + U(1 - \cos \theta) \sin \alpha}{\sin \theta} \\ &\rightarrow \frac{U(\theta + \dots) \cos \alpha + U(\frac{1}{2}\theta^2 + \dots) \sin \alpha}{\theta + \dots} = U \cos \alpha, \end{aligned}$$

which is the required finite limit: the flow leaves the trailing edge with a finite speed.

---

Finally, from our previous analyses, we know that, in the  $Z$ -plane, we have the same flow (uniform speed  $U$ , angle of incidence  $\alpha$ ) past the flat-plate aerofoil. Furthermore, the circulation maps to the same circulation in the  $Z$ -plane; thus the Kutta-Joukowski theorem gives the lift as  $\rho UK$  (per unit length out of the plane), and so the lift generated by the flat-plate aerofoil, at right angles to the oncoming stream, is

$$\rho UK = 4\pi a \rho U^2 \sin \alpha \quad (\text{per unit length}).$$

Here, we have taken the density of the fluid to be  $\rho$ ; note that the lift is proportional to the *square* of the speed and to the sine of the angle of incidence. Thus the lift increases significantly with speed, and a positive angle of incidence,  $\alpha > 0$ , is required; for zero angle the lift is zero. For sufficiently large angles – about  $10^\circ$ – $15^\circ$  for a flat plate – the wing stalls; our current theory fails when this happens (and neither can it predict when this will occur).

The expression for the complex velocity on the plate, using the  $K$  above, gives

$$\frac{dw}{dZ}|_{\text{plate}} = \frac{2aU[\sin(\theta - \alpha) + \sin \alpha]}{2a \sin \theta}.$$

Thus there is a stagnation point where

$$\sin(\theta - \alpha) = -\sin \alpha \quad (\text{for } \theta \neq 0, \text{ which is the trailing edge});$$

this has only one solution:  $\theta = \pi + 2\alpha$ , and this is on the under-side of the plate, and further back from the leading edge than when circulation was absent; see §5.2. A schematic representation of the effect of the circulation on the stagnation points is shown in this figure:

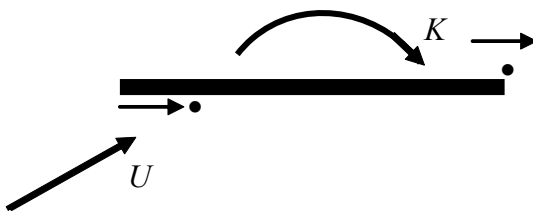

The resulting flow pattern takes the form shown below, where the first figure shows the orientation in the chosen coordinate system, and the second relative to the oncoming (horizontal) stream:

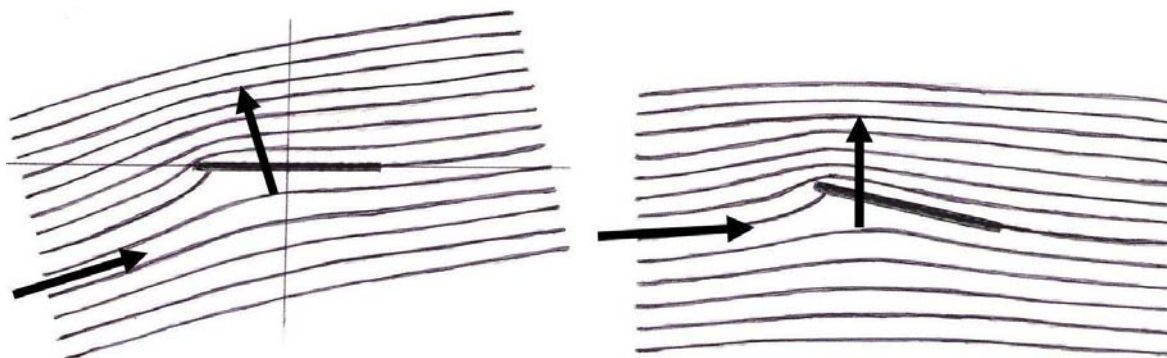

**Comment:** There is a technical issue that we have somewhat glossed over here. The circle in the  $\zeta$ -plane, which maps to the aerofoil, contains two singularities on its boundary when the mapping is performed (where we have the two branch points,  $\zeta = \pm a$ ). This indicates that the evaluation of the contour integral, to find the complex force, may not be straightforward – perhaps not even defined. First, the integral must be on a contour where we have the complex velocity defined, and this must be where the fluid exists; it is a moot point whether this is the case on the circle. Certainly, we may elect to use a contour that is strictly in the fluid, but as close as to the circle as we wish. This then ensures that all three poles (associated with each branch point) sit inside the contour (and such a contour will map to a closed contour that is in the fluid in the  $Z$ -plane, but as close as we wish to the flat plate). Indeed, because there are no other poles, we could choose *any* contour that surrounds the circle/plate. This leaves just one critical issue: the residues of the poles at the origin and at  $\zeta = a$  are well-defined – the first is the expected contribution from the circulation, and the second is certainly finite by virtue of the Kutta condition – but what of the third? The velocity here is infinite, so the contribution to  $(dw/dZ)^2$  may not lead to a finite value for the Blasius integral. (We note that, for a realistic aerofoil, this is not an issue: such an aerofoil will be round-nosed, with finite speeds everywhere – this third pole will certainly not be on the contour.) A detailed evaluation, from first principles (without recourse to the Kutta-Joukowski theorem) is given in Appendix 6; this confirms the result given by that theorem.

The lift of an aerofoil is usually quoted as a lift coefficient (cf. §4.6):

$$C_L = \frac{\rho U K}{\frac{1}{2} \rho U^2 (4a \times 1)} = 2\pi \sin \alpha ,$$

where the term  $(4a \times 1)$  is the surface area of the wing: the length of the section – the *chord* ( $4a$ ) – times per unit length out of the plane. Typically, the maximum, without flaps extended, is about  $1.5$ , but it can be about  $3.0$  with flaps and slats extended. Most wings, without flaps or slats extended, will stall at about  $15^\circ$ , or a little higher, depending on the specific shape of the aerofoil section; see §5.2.

**Comment:** There is a corresponding drag coefficient, which measures the total drag (which has a number of different contributors) on a wing or, more importantly, on the whole aircraft. The ratio of lift/drag is often quoted; for example, we have the following approximate values (relevant to cruising or soaring flight):

Boeing 747	17
Concorde & Space Shuttle	7
Herring gull	10
Sparrow	4
High-performance glider, max	70



**The financial industry needs a strong software platform**  
*That's why we need you*

Working at SimCorp means making a difference. At SimCorp, you help create the tools that shape the global financial industry of tomorrow. SimCorp provides integrated software solutions that can turn investment management companies into winners. With SimCorp, you make the most of your ambitions, realising your full potential in a challenging, empowering and stimulating work environment.

Are you among the best qualified in finance, economics, computer science or mathematics?

**Find your next challenge at [www.simcorp.com/careers](http://www.simcorp.com/careers)**

Mitigate risk | Reduce cost | Enable growth  
[simcorp.com](http://simcorp.com)

**SimCorp**

*"When I joined SimCorp, I was very impressed with the introduction programme offered to me."*

Meet Lars and other employees at [simcorp.com/meetouremployees](http://simcorp.com/meetouremployees)



We address one final issue related to the flat-plate aerofoil: what is the *line of action* of the lift force? That is, along what line must the force act (which is the resultant of the pressure distribution around the aerofoil) to produce the moment of all the pressure forces? To answer this, we must find the moment of the forces, and Blasius' moment theorem does that for us; see §4.8. This calculation, which follows that for the force quite closely, produces the moment (counter-clockwise)  $M = -\rho a UK \cos \alpha$  :

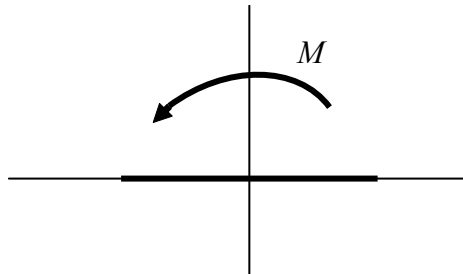

the details of this, although routine, will not be developed here. We can find a version of this moment by computing directly, using the known force:

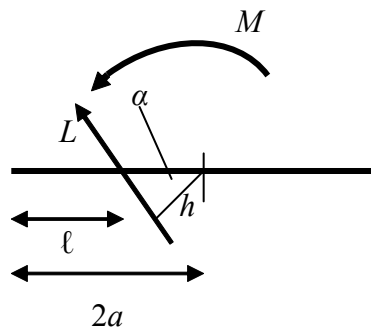

The lift force,  $L$ , passes through a point that is a distance  $\ell$  from the leading edge; this line of action of the force is a perpendicular distance  $h$  from the centre of the plate (and note that the force is at right angles to the oncoming stream, which is at an inclination  $\alpha$ ). Thus the moment of this force, clockwise, is

$$hL \text{ where } h = (2a - \ell) \cos \alpha \text{ and } L = \rho UK ,$$

and so we obtain  $(2a - \ell)\rho UK \cos \alpha = \rho UK a \cos \alpha$  i.e.  $\ell = a$  .

Thus the line of action of the lift force is a distance  $a$  back from the leading edge of the flat plate, a position usually called the  $\frac{1}{4}$ -chord point i.e. one quarter of the chord from the leading edge. (All aerofoils have the line of action approximately at the  $\frac{1}{4}$ -chord point, the variation depending on the detailed shape of the aerofoil and the angle of incidence. Consequently, all aerofoils – wings – suffer a ‘pitching-up’ moment; this is readily demonstrated when an attempt is made to ‘fly’ a flat plate e.g. a sheet of card: it will immediately flip up and rotate backwards!)

### 5.4 The general Joukowski aerofoil in a flow

Finally, we consider all the ideas and techniques developed thus far, and apply them to the general Joukowski aerofoil placed in a uniform stream at a general angle of incidence. Thus we formulate the problem, in the  $\zeta$ -plane, of the uniform flow (speed  $U$ ), at an angle of  $\alpha$  to the positive  $x$ -axis, past a circle with circulation. The circle has its centre at a general point ( $\zeta = c$ ), but it encloses  $\zeta = -a$  and passes through  $\zeta = a$ ; see §5.1(e). The circle is  $\zeta = c + re^{i\theta}$ , and it is convenient to associate  $\zeta = a$  with  $\theta = -\beta$  (and note the choice of sign); the flow configuration is:

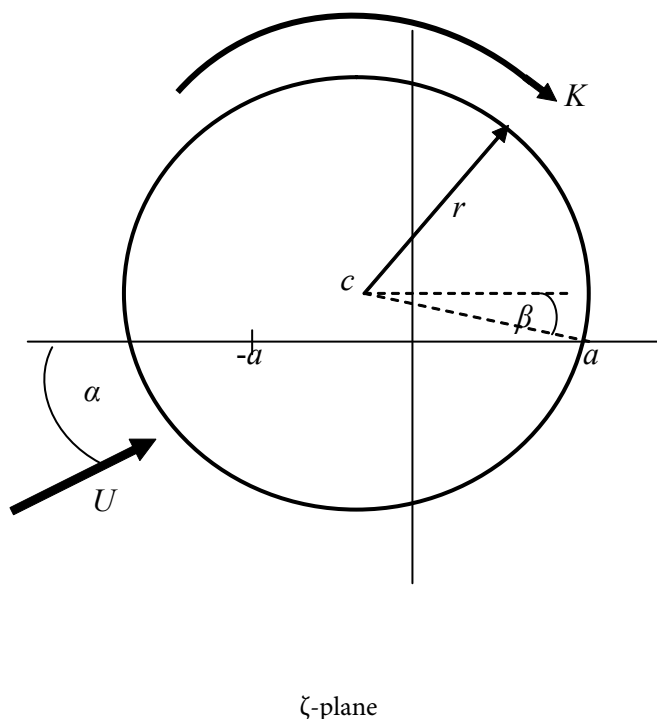

**Note:** Increasing  $\beta$  moves the centre of the circle in the positive  $y$ -direction (but keeping all other conditions unchanged), and so the curvature (or camber) of the aerofoil will increase.

The complex potential for this flow, with a suitable origin shift and using the radius of the given circle ( $r$ ), is therefore

$$W(\zeta) = U(\zeta - c)e^{-i\alpha} + Ue^{i\alpha} \frac{r^2}{\zeta - c} + i \frac{K}{2\pi} \log(\zeta - c);$$

this is most easily obtained by following the development for the flat plate (§5.3), with the radius  $r$ , and then replacing  $\zeta$  by  $\zeta - c$  (to accommodate the origin shift). (We observe that this can be accomplished without bothering to ‘shift’ the first term in this expression: the additional term so generated is a constant, which can be ignored – as we know.) From our earlier discussions, it is sufficient to impose the Kutta condition in order to find the appropriate choice for the circulation,  $K$ .

The Kutta condition, at  $Z = 2a$  (i.e.  $\zeta = a$ ), requires us to find, first,

$$\frac{dw}{dZ} = \frac{dW}{d\zeta} \frac{d\zeta}{dZ} = \frac{U \left( e^{-i\alpha} - \frac{r^2}{(\zeta - c)^2} e^{i\alpha} \right) + i \frac{K}{2\pi} \frac{1}{\zeta - c}}{1 - a^2/\zeta^2}$$

and remember that, although the circle used here is of radius  $r$ , the JT still involves the parameter  $a$ . This is now evaluated on the aerofoil (for which  $\zeta = c + re^{i\theta}$ , and  $\theta$  is the parameter that now maps out the aerofoil):

$$\left. \frac{dw}{dZ} \right|_{\text{aerofoil}} = \frac{U \left( e^{-i\alpha} - e^{-i2\theta} e^{i\alpha} \right) + i \frac{K}{2\pi r} e^{-i\theta}}{1 - a^2/(c + re^{i\theta})^2}$$

The Kutta condition requires that this expression be finite as  $Z \rightarrow 2a$  i.e.  $\theta \rightarrow -\beta$

( $\zeta = a$ ), and so the numerator must be zero at this point (for a finite limit to exist; see §5.3). Thus we have the condition

$$U \left( e^{-i\alpha} - e^{i(\alpha+2\beta)} \right) + i \frac{K}{2\pi r} e^{i\beta} = 0 \text{ or } i \frac{K}{2\pi r} = U \left( e^{i(\alpha+\beta)} - e^{-i(\alpha+\beta)} \right),$$

and so  $K = 4\pi U r \sin(\alpha + \beta)$ .

The lift, via the Kutta-Joukowski theorem, is then

$$4\pi r \rho U^2 \sin(\alpha + \beta)$$

per unit length out of the plane; this force increases with the square of the speed – as we have seen previously – and with the angle of incidence  $\alpha$ , and now also with increased curvature (camber) of the aerofoil, which is the effect of increasing  $\beta$ . A typical flow pattern for a realistic (Joukowski-type) aerofoil, as obtained in the laboratory, is shown below

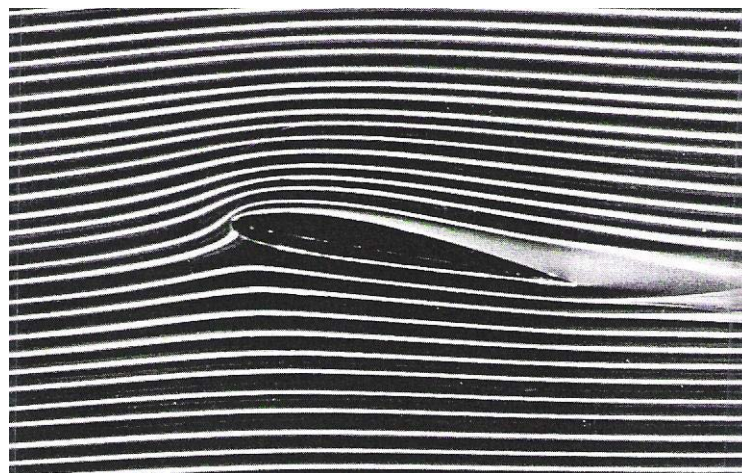

and a MAPLE programme that generates Joukowski aerofoils, and the associated streamlines, is given in Appendix 7.

**Comment:** An aircraft wing is designed and constructed so that its geometry changes, depending on the conditions of flight; there are three main stages: take off, cruising flight, landing. The aim is to have the most efficient (minimum drag) configuration during the cruising phase; for this the aerofoil shape is the most streamlined, without flaps or slats (which are like forward flaps). However, to reduce speeds at take off and landing, the required lift is to be generated at lower speeds – and the normal design requirements are that the lowest speed is in the landing phase. At take off, the flaps are extended and lowered, usually to about  $30^\circ$  (' $30^\circ$  flap'); this, in the context of our result, means that both  $r$  and  $\beta$  are increased beyond the normal resting/cruising values. Thus the lift force required to get the aircraft off the ground occurs at a lower speed than for the same lift without flaps; of course, the drag is significantly increased so more thrust is needed. The same procedure is adopted for landing, but now the flaps are extended further and lowered more (typically about  $60^\circ$  flap) and slats – a forward extension and lowering at the leading edge – are often also deployed. This produces the required lift at an even lower speed (but with more drag and so higher thrust is required). This describes, in broad outline, how our introductory ideas for the generation of lift are incorporated within the design and flight of aircraft.

The classical theory of lift, which does not use any details associated with the rôle of viscosity, gives estimates for the lift that are correct to within about 90% (and often considerably better than this). As we have mentioned, our theory does not address the issue of drag (and therefore estimates for the thrust required to get the aircraft off the ground). One important additional consequence of the neglect of viscosity is that, without a careful analysis of the boundary layer on the wing, we cannot predict boundary-layer separation and the onset of the stall.

**Concluding comments:** We list a few points that provide the start of a more comprehensive study of aerofoils and flight.

(a) The forces on an aircraft are represented schematically by

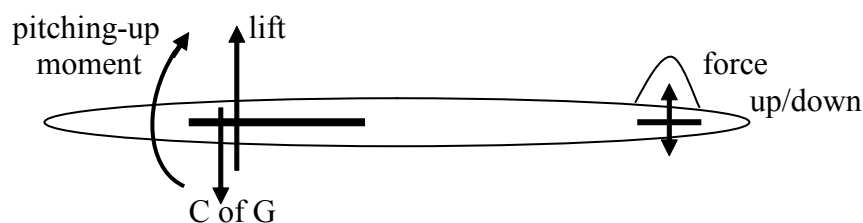

which suggests that the rôle of the tail is to counteract the pitching-up moment associated with the lift generated by the wings. However, the centre of gravity (C of G) is normally adjusted so that this provides a moment sufficient to pitch the aircraft down. (Indeed, this is the essential requirement for an aircraft that is stable: any loss of lift on the wings causes the nose to drop, enabling the flow to reattach, so that lift is recovered.) The tail is used, primarily, to produce a downwards force that pushes the nose up, thereby ensuring that the angle of incidence is that required to generate the lift. The tail fin is to provide lateral stability, although turning requires the use, in addition, of ailerons – which was the main discovery made by the Wright brothers.

(b) Our aerofoil, a Joukowski aerofoil, has one structural draw back: there is a cusp at the trailing edge, and cusps cannot be built! There are two comments that we should make about both this and a related issue. The first is quite general: there is an extension of the ideas presented here that enable *any* shape to be represented and analysed in the complex plane (although the technical details are, not surprisingly, rather more involved). Thus any shape of aerofoil, with or without flaps and slats, can be investigated; in particular, the cusp in our aerofoil shapes can be removed. The second point relates specifically to this aspect of our Joukowski aerofoils.

The JT that we used is  $Z = \zeta + a^2/\zeta$ ; this can be rewritten as

$$\frac{Z+2a}{Z-2a} = \frac{\zeta + a^2/\zeta + 2a}{\zeta + a^2/\zeta - 2a} = \left( \frac{\zeta + a}{\zeta - a} \right)^2.$$

It turns out that the related, more general, transform which replaces '2' by '2 -  $\varepsilon$ ' throughout i.e.

$$\frac{Z + (2 - \varepsilon)a}{Z - (2 - \varepsilon)a} = \left( \frac{\zeta + a}{\zeta - a} \right)^{2 - \varepsilon},$$

generates, for small  $\varepsilon$ , virtually identically-shaped aerofoils, but these have an included angle  $\varepsilon\pi$  at the trailing edge – not a cusp. [This is called a von Kármán-Trefftz transform.]

(c) A fully three-dimensional theory is available, enabling finite wings, with wing tips, to be analysed. This is based on the idea of circulation, producing vorticity in the flow – and observed by the vortex shedding at wing tips – the vorticity being distributed along a line (or region) that is in the aerofoil section and then leaves it, and moves downstream. [This is usually called the 'horseshoe vortex' and is an extension of 'lifting-line' theory.]

(d) The interaction between the inviscid (complex variable) flow and the viscous boundary layer can be analysed. Because the boundary layer is thin – we are dealing with large Reynolds numbers – this has little effect on the flow around the aerofoil. The technique is to solve the inviscid-flow problem (using complex variables), and then use this as the exterior flow to a boundary layer on a curved plate. This, in turn, is analysed and used as the basis for adjusting (very slightly) the 'shape' as seen by the exterior flow; this is then further iterated. [The description here is the mathematical idea, which has a robust analytical basis; of course, much of this type of calculation can now be done, in its totality, by suitable numerical methods.]

(e) Finally, we mention that the generation of lift for a supersonic aerofoil is rather different. Those familiar with high-speed (usually military) aircraft will have observed that the wings are essentially flat and thin – they are not shaped, in any fashion, like the aerofoils that we have been discussing here. The pressure difference that gives rise to the lift is generated, in supersonic flow, by the property that pressure in the flow changes as it passes through a shock wave. The angle of incidence in the supersonic flow produces a suitable shock wave, enabling the flow to change direction (and correspondingly, the pressure):

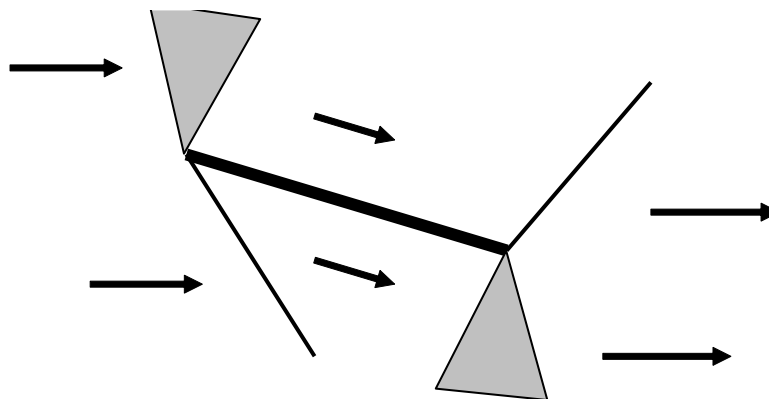

This figure represents the flow over a supersonic aerofoil; the flow directions are given by the arrows and the two thinner lines are the shock waves. Shock waves arise only if the flow turns to decrease the angles in the respective flows; if the angle increases, then an ‘expansion fan’ is generated – the grey areas in the figure – but the essential features are the same: the angle of the flow changes and the pressure changes. With the appropriate configuration, the pressure underneath is greater than that on top, and so lift is generated.

### Exercises 5

**108. Joukowski transformation: cambered plate.** Analyse the parametric representation of the cambered plate obtained from the circle  $|\zeta - ik| = r$  where  $k (> 0)$ , with  $z = \zeta + a^2/\zeta$  and  $r^2 = a^2 + k^2$ ; see §5.1(c). On the basis of this, sketch the graph of this shape, confirming that each branch (upper/lower) is the arc of the same circle, OR use suitable software (e.g. MAPLE) to plot the shape produced by this parametric form.

**109. Symmetric aerofoil.** Show that a symmetric aerofoil is obtained from the circle  $|\zeta| = a$  via the transformation  $z = \zeta + b + \frac{(a-b)^2}{\zeta + b}$ ,  $0 < b < a$ . Now show that, for the choice  $b/a < 1$ , then the areofoil has the approximate parametric representation

$$x = 2a\{\cos\theta + (b/a)(1 - \cos\theta - \cos^2\theta)\}, y = 2b(1 + \cos\theta)\sin\theta.$$

Use suitable software (e.g. MAPLE) to plot this shape, with  $a = 1$  and  $b = 0.1$ .

**110. Flow past ellipse.** Write down the complex potential for the uniform flow (speed  $U$ , angle of incidence  $\alpha$ , no circulation) past the circle  $|\zeta| = c$ . Hence use the Joukowski transformation  $z = \zeta + a^2/\zeta$  ( $0 < a < c$ ) to find the complex potential for the same flow in the  $z$ -plane past the ellipse

$$(x/\cosh \beta)^2 + (y/\sinh \beta)^2 = 4a^2, \text{ where } \beta = \ln(c/a).$$

- 111. Velocity at trailing edge.** Write down the complex potential for the uniform flow (speed  $U$  and angle of incidence  $\alpha$ ) past the flat plate  $z = 2a \cos \theta$  ( $0 \leq \theta \leq 2\pi$ ). Include a general circulation  $K$  (clockwise), apply the Kutta condition at  $z = 2a$  and hence determine the velocity in the flow field for  $z \rightarrow 2a$ .
- 112. Symmetric Joukowski aerofoil.** A uniform flow, of speed  $U$  and angle of incidence  $\alpha$ , past the symmetric Joukowski aerofoil, is obtained by transforming the circle  $|\zeta + c| = r$  (real  $c > 0$ ,  $r - c = a$ ) under  $z = \zeta + a^2/\zeta$ . Introduce a circulation, apply the Kutta condition and hence state the lift (per unit span) generated by the aerofoil.

Further, given that the moment (clockwise) about the origin of this lift force is

$$2\pi\rho U^2(a^2 + r^2 - ar) \sin 2\alpha,$$

show that the resultant lift force acts through a point which approaches the  $1/4$ -chord point as  $c \rightarrow 0$ .

- 113. An extended Joukowski transformation.** Show that the conformal transformation

$$z = \zeta + \frac{3a}{2} + \frac{3a^2}{4\zeta} + \frac{9a^3}{8\zeta^2},$$

where  $a (> 0)$  is real, possesses a branch point at  $\zeta = 3a/2$ . Further, show that the circle  $|\zeta| = 3a/2$  maps into the aerofoil represented by the parametric form  $x = a(1 + \cos \theta)^2$ ,  $y = a(1 - \cos \theta) \sin \theta$ ; give a rough sketch of the shape of this aerofoil.

Now a uniform flow (speed  $U$ , angle of incidence  $\alpha$ ) past the circle is mapped into the same flow past the aerofoil; introduce circulation ( $K$ , clockwise), apply the Kutta condition to find that  $K = 6\pi a U \sin \alpha$  and hence state the lift (per unit span) generated by the aerofoil.

- 114. Behaviour near the trailing edge.** The circle  $|\zeta| = a$  is mapped into the flat-plate aerofoil under the transformation  $z = \zeta + a^2/\zeta$ . Show that, near  $z = 2a$ , we have the property  $\frac{d\zeta}{dz} = \frac{1}{2} \frac{\sqrt{a}}{\sqrt{z-2a}}$ , approximately.
- 115. Thin elliptical aerofoil.** The circle  $|\zeta| = (1 + \varepsilon)a$ , where  $0 < \varepsilon < 1$  is a parameter, maps into an ellipse under the Joukowski transformation  $z = \zeta + a^2/\zeta$ . Show that the semi-major and semi-minor axes of the ellipse are approximately  $2a$ ,  $2\varepsilon a$ , respectively, for small  $\varepsilon$ .

This ellipse is placed in a uniform flow of speed  $U$  and angle of incidence  $\alpha$ ; introduce a suitable circulation,  $K$ , and choose it to satisfy the Kutta condition at the trailing edge. For small  $\varepsilon$ , find approximations to (a) the circulation,  $K$ ; (b) the lift (per unit span); (c) the position of the stagnation point; (d) the velocity near to the leading edge ( $z \approx -2a$ ).

\*\*\*\*\*

# Appendixes

## Appendix 1: Biographical Notes

We provide a set of brief biographical notes on the various individuals who have contributed to the development of fluid mechanics, and aerofoil theory, and who are mentioned in this text.

### **Bernoulli, Daniel (1700-1782)**



Daniel was a Dutch-born member of the famous Swiss family of about 10 mathematicians (fathers, sons, uncles, nephews) – he was the son of Johann and his uncle was Jacob – best known for his work on fluid flow and the kinetic theory of gases; his equation for the flow of an inviscid fluid first appeared in 1738. He qualified, initially, as a medical doctor, then was appointed a professor of mathematics (in St Petersburg), but then moved to anatomy and botany and, eventually, physics! It was during this period that he defined the nodes and frequencies of an oscillating system, and showed that the movement of strings in musical instruments could be represented as an infinite number of harmonic modes. However, his most important work at this time was his analysis of fluid motion, culminating in his work *Hydrodynamica*, which gave us the word ‘hydrodynamics’. In his studies, he also made contributions to astronomy and magnetism, and was the first to solve the Riccati equation, but his general and main interests were in trigonometry, the calculus and probability. He was a close friend of both Euler and d’Alembert.

### **Blasius, P.R.H. (1883-1970)**

Blasius was a student of Prandtl (in Göttingen 1902-1906) and then, from 1908, a research assistant at a hydraulics laboratory in Berlin; from 1912 he became a teacher at a technical college in Hamburg – he claimed to have been a scientist for only 6 years, thereafter becoming a teacher. He wrote a few papers (in addition to his important two) on various problems in hydraulic engineering and aircraft stability, and undergraduate texts on heat transfer and mechanics.



### **Coanda, Henri (1886-1972)**



Coanda was born in Bucharest (Romania), where his father was a professor of mathematics at the National School of Bridges and Roads; he claimed that he was always interested in the ‘miracle of wind’. Although he graduated as an artillery officer, he was intrigued by the technical aspects of flight. He joined a French aircraft company, and also spent three years (1911-1914) with the Bristol Aircraft Company, designing a number of early aircraft. Throughout the first and second World Wars, he worked in France. The ‘Coanda effect’, in which a flow is attracted to, and remains attached to, a nearby solid boundary, was investigated by Coanda between the wars.

**Couette, M.M.A. (1858-1943)**

Couette was born, and spent his life, in France. He first obtained a baccalauréat in humanities, and then bachelor's degrees in mathematics (1877) and physics (1879); after this, he studied at the Sorbonne under Boussinesq, finally obtaining (1890) his PhD at the Physics Research Laboratory, working on the friction of fluids. He was appointed a professor of physics at the Catholic University of Angers, and lived there for the rest of his life, but he was poorly paid, so took extra teaching jobs at various colleges nearby. He designed a concentric-cylinder viscometer (to measure the viscosity of fluids), and demonstrated the correctness of the 'no-slip' boundary condition.

**Euler, Leonhard (1707-1783)**

Euler, a Swiss mathematician (born in Basle), is regarded as the most prolific mathematician (ever); his powers of calculation (without the aid of paper) was prodigious – he continued to work throughout the years at the end of his life when he was totally blind. (He lost his sight in the right eye in about 1733, and in the left about 1768.) He studied under Johann Bernoulli, obtaining his master's degree at the age of 16; because of his age, he was unable to find a university post, but by the age of 20 he was appointed to the Naval College in St Petersburg (and served as a medical lieutenant in the Russian navy), becoming Professor of Physics there in 1730. During this period, he shared rooms with Daniel Bernoulli (who held the mathematics chair), and when Daniel returned to Basle, Euler was appointed in his place.



Euler contributed to all the (classical) fields in pure and applied mathematics: analysis, calculus, trigonometry (where he was the first to treat sin, cos, etc., as functions), analytical geometry, series (with convergence), ordinary and partial differential equations, number theory, mechanics, celestial mechanics, fluid mechanics, acoustics, optics; he also laid the foundations for analytical mechanics. He made popular the notation ' $\pi$ ' (which had been used first by William Jones in 1706), and introduced ' $e$ ', ' $i$ ' and ' $\Sigma$ ', as well as the (now) very familiar notation for a function:  $f(x)$ .

He was not as rigorous in his approach as, say, Gauss or Cauchy, but he had the ability to see structure by intuition or by developing new approaches; he could be regarded as one of the foremost mathematicians (just behind Archimedes, Newton and Gauss – the big three).

**Flettner, Anton (1885-1961)**

Flettner was a German aviation engineer and inventor, specialising in the application of circulatory motion in an air flow. He invented the servo tab (fitted to flaps), initially for use on the Graf Zeppelin; while working for this company in WWI, he developed remote control and pilotless aircraft, and wire-guided ground-to-air missiles. Between the wars, he directed a research institute in Amsterdam. It was during this period that he had the idea for a rotating cylinder as the basis for propulsion on ships. He developed and built the *Baden-Baden* which sailed across the Atlantic (1926); a second ship, the *Barbara*, was built and sailed to America (but it was destroyed in a storm). Under moderate wind conditions, his device could out-perform a conventional sailing vessel.

During and after WWII (when he moved to the US), he specialised in helicopter design, although he made his fortune with the invention of the rotary ventilator (still used on many vehicles as a non-powered device for ventilation).

**Froude, William (1810-1879)**

Froude was an English engineer, specialising in hydrodynamics and naval architecture, although he started with a first in mathematics from Oxford University (Oriel College). He worked with Brunel as a surveyor on the South Eastern Railway, being responsible for the section between Bristol and Exeter. He developed the standard methods for laying out track transition curves, but he was then encouraged by Brunel to examine the stability of ships under steam. Thus he was able to identify the most efficient hull shapes – minimum drag with stability – and in the process showed how scale-model results could be used with accuracy on the full-scale ship. On the back of his successes, the Admiralty funded the construction of the first ship-testing tank – at his home in Torquay!

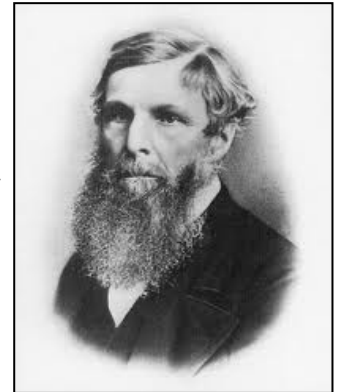

ENGINEERING, RESEARCH AND OPERATIONS



# 85

years of  
innovation

- > 113,000 employees
- > 140 nationalities
- > 85 countries of operation

[careers.slb.com](http://careers.slb.com)

<sup>1</sup> Based on Fortune 500 ranking 2011. Copyright © 2012 Schlumberger. All rights reserved.

**Who are we?**  
We are the world's largest oilfield services company<sup>1</sup>. Working globally—often in remote and challenging locations—we invent, design, engineer, and apply technology to help our customers find and produce oil and gas safely.

**Who are we looking for?**  
We're looking for high-energy, self-motivated graduates with vision to work in our engineering, research and operations domain.

**What will you be?**

Schlumberger



**Gauss, (J.)K.F. (1777-1855)**

Gauss was the pre-eminent German mathematician (and astronomer and physicist) of all time, regarded as one of the top three (with Archimedes and Newton, yet his interests went far beyond both these). He came from a poor, and ill-educated family, but his talents were soon recognised: it is reported that he was correcting his father's arithmetic by the age of 3 and by 8 years he was adding large arithmetical sequences (based on new general principles that he had discovered). He received his doctorate (from the University of Helmstadt) in 1799, although most of his lectures were at Göttingen. He was making fundamental discoveries in mathematics from the age of about 14, although much of this was not published (but we know about his work because he kept detailed notebooks, which have been thoroughly examined since his death). He had considerable knowledge of, and skills in, many languages – he almost became a philologist – and then at the age of about 22 he decided to develop his interests in astronomy. Indeed, by 1807 he was Professor of Mathematics at Göttingen and also director of its observatory.

His discoveries, many of which were rediscovered by others decades later, would fill many texts. He did fundamental work in: number theory (particularly the problem of the distribution of primes), quadratic residues, extended Euclidean geometry – the first to do so for 2000 years (and he was then about 20), introduced non-Euclidean geometries, analysed the rôle of complex numbers in solving *all* algebraic equations, found efficient calculation schemes for the motion of celestial bodies, complex analysis, elliptic functions, theories of surfaces, topology, conformal mapping, geodesy, mathematical physics, electromagnetism, optics – and much, much more. It has been argued that, if he had published at the time of discovery, mathematics would have advanced by at least 50 years, during the 19<sup>th</sup> century, as compared with the actual developmental time scales.

**Hagen, G.H.L. (1797-1884)**

Hagen is credited with the first observation of laminar and turbulent flows, reported in 1839, and expanded in 1855, and with the measurement of velocity profiles for flows through pipes. (The transition from laminar to turbulent flows was explored and developed by Reynolds in 1883.) He was born in what is, today, Kaliningrad in Russia, and studied mathematics, architecture and civil engineering; he joined his *alma mater* (University of Königsberg), being responsible for projects in hydraulic engineering. Thereafter, he was a construction official for the local mercantile community, then harbour inspector and finally (from 1830) he worked on constructions in Berlin, also teaching at the university there.

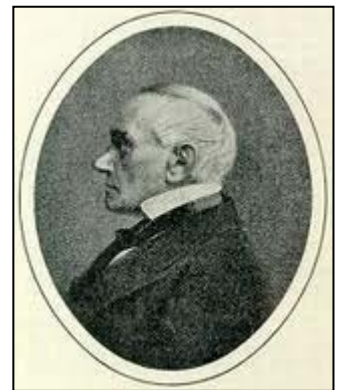

**Helmholtz, H.L.F von (1821-1894)**

Helmholtz originally planned to study physics, but his family's financial position made this impossible, so he opted for medicine (for which there was a government stipend available). Although he completed his medical studies, he spent most of his time studying all the work then currently in print on both physics and mathematics. This interest continued even after his appointment as surgeon to the Potsdam regiment (which is where he was born). In 1855, he was appointed to the chair of anatomy and physiology at the University of Bonn, where he found it difficult to continue his work in physics – even though he was gaining a considerable reputation in this area. He was able, eventually, to develop his real interests, first at Heidelberg and then at Berlin University.

He was the first to suggest the importance of vorticity – he introduced the word – and the rôle of vortex filaments and vortex sheets; he was also the first to use the term 'velocity potential', and showed its relevance to fluid flows. In short, he explained the difference between rotational and irrotational flows. He also introduced the concept of energy conservation, as well as making important contributions to the theories of electricity and magnetism; he added to our understanding of the physiology of sight and colour vision, and he measured the speed of nerve impulses.

**Joukowski, N.E. (or Zhukovsky or Zhukovskii) (1847-1921)**

His father was a communications engineer, so it was only natural that he studied in the Faculty of Physics and Mathematics at Moscow University, where he chose to specialise in applied mathematics. Thereafter, he taught mathematics – mainly mechanics – and also obtained his master's degree (equivalent to a modern doctorate). He moved, first, to the Moscow Technical School, and then (in 1882) to Moscow University. He wrote over 200 papers and, perhaps more significantly, founded the Russian schools of hydromechanics and aerodynamics; indeed, he is often regarded as the 'father of Russian aviation'.

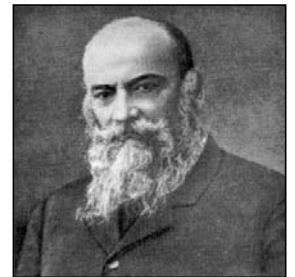

He began an extensive study of flight dynamics in 1891, visiting Lilienthal and purchasing one of his gliders. His publications in 1906 gave the theoretical expressions for lift: the Kutta-Joukowski theorem (because Kutta had produced something similar in 1902). During WWI he taught a special course for Russian pilots.

Joukowski also made contributions to general hydrodynamics and hydraulics, analysing shock waves in water pipes, for example, and to the design of dams. In addition, he wrote on the theory of pendulums, on the rotation of solid bodies and gave the first comprehensive analysis of the gyroscope.

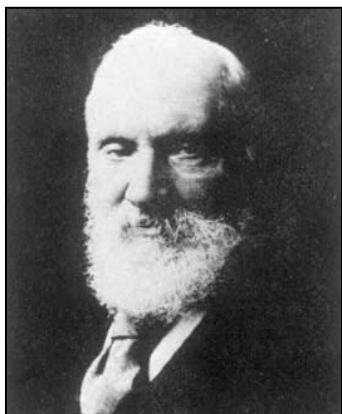
**Kelvin, Lord (W. Thomson) (1824-1907)**

William Thomson was born in Belfast, where his father was a professor of engineering but, when William was 8, he father was appointed to a chair in mathematics at Glasgow University. He started he studies at this university at the age of 10 – not all that unusual at this time, as Scottish universities acted as schools for able students – but he did begin degree-level mathematics at the age of 14; he later moved to Cambridge (graduating in 1845). He was appointed Professor of Natural Philosophy, at Glasgow, at the age of 22, and remained there for the rest of his working life. (He had produced some important results in electrostatics while an undergraduate, and was awarded a gold medal (age 15) for an analysis on the shape of the Earth. By the age of 16 he had mastered Fourier’s work on heat transfer and Laplace’s on celestial mechanics.)

He was the foremost physicist and electrical engineer of his time, pioneering the studies of electrodynamics and thermodynamics, and planning and directing the laying of the first transatlantic telegraph cable. He consolidated the electrical and magnetic work of Faraday, and developed the theory of heat transfer beyond the work of Fourier and Carnot. He introduced the absolute temperature scale and formulated the Second Law of Thermodynamics (also developed by Clausius). He worked on hydrodynamical problems with Stokes, between 1847 and 1849, these two exchanging no less than 656 letters on the subject over this period.

He was probably the first scientist to make a personal fortune – on the back of his cable work – but he hated vectors! (He never used them, and so made many calculations far more cumbersome than they need be.)

**Kutta, M.W. (1867-1944)**

Kutta was born in Pitschen (Germany), which is now in Poland; his parents died when he was young, and so he was brought up by an uncle in Breslau. He studied, first, at the University of Breslau, and then at the University of Munich, followed by the appointment as an assistant in the mathematics department at the Technische Hochschule in Munich; he spent a year at Cambridge and then received a PhD from Munich University (1902) on aerodynamic lift. (His interest in flight was sparked by the flights, and experimental observations, made by Lilienthal.) He then held a number of professorships, culminating in a post at Stuttgart (Technische Hochschule) in 1911; he remained there until he retired in 1935.



His thesis contains the Runge-Kutta method for the numerical solution of differential equations, and in his ‘habilitation’ thesis – required for university teaching in Germany – he developed his theory for flight (the Kutta condition, and his version of the Kutta-Joukowski theorem). However, he devoted most of his time to teaching mathematical techniques and ideas to engineers. Nevertheless, he did some important work on the motion of glaciers; he also maintained a keen interest in the history of mathematics.

**Lagrange, J.-L. (1736-1813)**

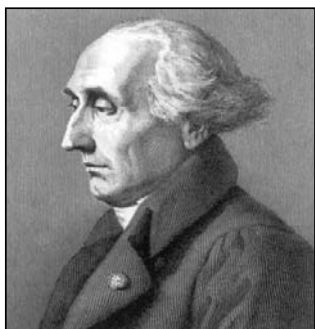

Lagrange was born in Italy (Turin), and he originally had an Italian name, but his family had strong French connections, and he generally thought of himself as French (so he would often sign his name ‘Lodovico LaGrange’ or ‘Luigi Lagrange’); the French regard him as French and the Italians as Italian! He studied at the College of Turin, initially specialising in Latin – he was not excited by mathematics (and found Euclidean geometry particularly boring). But he read Halley (on algebra in optics) and attended some good lectures on physics, so decided to devote himself to mathematics. Indeed, he was appointed a professor at Turin’s Royal Artillery School at the age of 19.

He regularly corresponded with Euler and, in 1766, succeeded him as Director of the Berlin Academy, when Euler returned to St Petersburg. In 1787 he moved to Paris, as a member of the Académie des Sciences, joining the newly-formed École Normale in 1795, as a full professor. His first important work was on the calculus of variations – but not called that for another dozen years (by Euler) – and these techniques he then applied to a number of problems. He also worked on the foundations of dynamics, based on the principle of least action, and on the theory of sound. At various times he also worked on: the three-body problem, and more general problems of stability in celestial mechanics, probability, fluid mechanics, the foundations of calculus, number theory (proving some of Fermat’s unproven theorems). In 1788, his important text (started when he was 19) entitled *Mécanique Analytique* was published, which transformed the study of mechanics into a branch of mathematical analysis. He also produced a text on the theory of analytic functions. He was a member of the committee that developed and introduced the metric system of weights and measures.



You’re full of *energy*  
*and ideas*. And that’s  
just what we are looking for.

Looking for a career where your ideas could really make a difference? UBS’s Graduate Programme and internships are a chance for you to experience for yourself what it’s like to be part of a global team that rewards your input and believes in succeeding together.

Wherever you are in your academic career, make your future a part of ours by visiting [www.ubs.com/graduates](http://www.ubs.com/graduates).

[www.ubs.com/graduates](http://www.ubs.com/graduates)



© UBS 2010. All rights reserved.



**Laplace, P.-S. (1749-1827)**

Laplace was born to a poor farming-family in Normandy, and he attended the local Benedictine school; in 1766 he entered the University of Caen to study theology, but after about a year he decided to move to Paris – his interests in science and mathematics had been awakened by one of his teachers. There he met d'Alembert (probably based on a letter of introduction) and immediately solved a problem that d'Alembert had proposed; d'Alembert was so impressed that he secured a professorship for him at the École Militaire in Paris and, by 1785, he held a senior position in the Académie des Sciences where he worked closely with Lagrange. He then started to produce a steady output of quite exceptional mathematical papers.

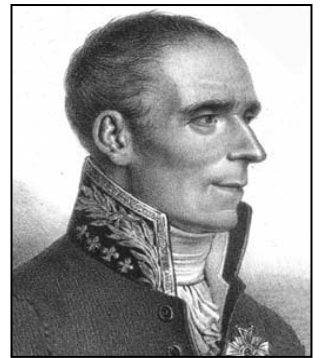

His first few papers were on determinants, on maxima and minima, and on aspects of the integral calculus, on difference equations and differential equations, and on the theory of probability. But then he turned to celestial mechanics and, in a sequence of important papers, discussed various aspects of the stability of gravitational orbits. In order to develop his arguments, he introduced the potential function for the first time, and then moved on to work with – as we now describe them – Laplace coefficients, orthogonal functions and the Laplace Transform. Between 1799 and 1825, he published his *Mécanique Céleste*, in five volumes, his most important work.

**Lilienthal, Otto (1848-1896)**

Lilienthal was of Swedish parentage, although he was born in Anklam (in the Pomeranian province of Prussia) and, while still at school, studied the flight of birds and thought of ways of emulating them. He moved to a technical school in Potsdam, and then trained with an engineering company, becoming a professional design engineer; his main work involved the design of machines for mining. He also invented a small steam engine, much smaller and lighter than those then currently available, which gave him financial freedom to spend time on his investigations into manned flight.

He began experimenting in 1867, in his own time, on the flow of air and how this flowed over shapes to generate lift. He eventually developed gliders that would lift him – he was the father of the hang-glider – making over 2,000 flights, starting in 1891, learning how best to generate lift and to control his flight. His flights were made, either from natural hills (obviously), but also from an artificial hill that he built near Berlin. His main control mechanism was the position of his body, but he supported the glider on his shoulders – rather than the modern technique of hanging below the frame – so only his lower body could move; there was a tendency for the glider to pitch down, from which recovery was difficult. He died in a crash, when he stalled and was unable to recover. The Wright brothers (see below) credited him with providing the main inspiration for their decision to design the first aircraft, although they found his technical data of little use (and so obtained their own from a wind tunnel they had built).

**Magnus, H.G. (1802-1870)**

Born to a wealthy merchant family, Magnus studied (receiving a private education) mainly mathematics and physics, graduating from Berlin University with a degree in chemistry and physics, and a doctorate (1827) based on his discussion of the properties of tellurium. He spent some time in Paris, working with Gay-Lussac and Thénard, returning to the University of Berlin as a lecturer in physics and technology, rising to a full professor in 1845. He had a reputation as an excellent teacher. His main research interests were in chemistry and physical chemistry, and he was, primarily, an experimental scientist rather than a theorist. It was in 1852 that he did some experiments, probably prompted by the observations of Robins (see below), on the forces exerted on spinning projectiles (from firearms). He confirmed what Robins had noted – and Euler had rejected as ‘spurious’ – and so this side force is still, often, referred to as the ‘Magnus effect’. However, any explanation for it had to wait until we had the work that was to underpin classical aerofoil theory.

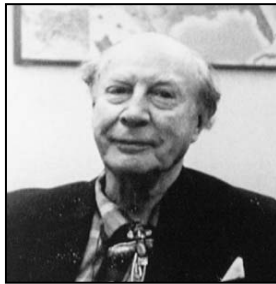
**Milne-Thomson, L.M. (1891-1974)**

Milne-Thomson first went to Clifton College (in Bristol) and then studied mathematics at Cambridge. He taught mathematics at Winchester College (1914) and then (1921) was appointed Professor of Mathematics at the Royal Naval College in Greenwich, where he remained throughout his working life. He taught various aspects of mathematics, but initially specialised in the construction of mathematical tables; this work led to his first text on the calculus of finite differences. Then, in 1938, he wrote an important text on hydrodynamics (which ran to five editions), and a book on aerodynamics (which had four editions). The second edition of ‘theoretical Hydrodynamics’ contains some new material, in particular his ‘circle’ theorem. After his work on tables, he produced a few papers covering various aspects of hydrodynamics, as well as a study of wind-tunnel interference and some contributions to stress analysis.

When he retired in 1956, he moved to the USA, being a visiting professor at a number of American universities, as well as, for short periods, in Italy and Australia; he returned to the UK in 1971.

**Mittag-Leffler, M.G. (1846-1927)**

He initially took the surname of his family – Leffler – but when a student, at the age of 20, changed it to ‘Mittag-Leffler’, Mittag being his mother’s maiden name. He originally trained (in Stockholm) as an accountant, but then moved to mathematics, studying at Uppsala University (Sweden). He received his doctorate there and then studied for a brief period in Paris (from 1873) and Berlin (from 1875); he was appointed to a chair at the University of Helsinki in 1876, and then to a chair at Stockholm University in 1881, where he stayed for the rest of his life. His is best remembered for his work on the analytic representation of meromorphic functions (being a generalisation of Weierstrass’ work), for his work on divergent series and for his founding of the journal *Acta Mathematica* (which his wife’s money helped to support). He also made contributions to more general aspects of the calculus and limits, to analytical geometry and to probability theory. His grand home, in the suburbs of Stockholm (in Djursholm) had one of the finest mathematical libraries in the world, at that time. This home, and its library, were bequeathed to the Swedish Academy of Sciences in 1916, and it has now become a major mathematical research centre: the Mittag-Leffler Institute.

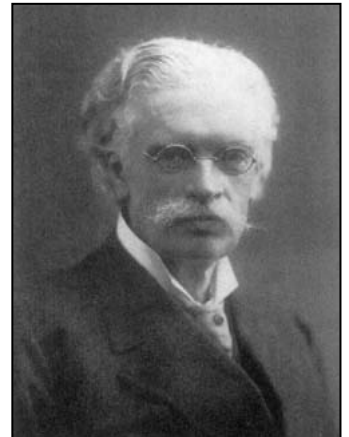
**Navier, C.L.M.H. (1785-1836)**

Navier’s father died when he was 8 years old, and his mother left him in Paris in the care of her uncle; she returned to her home town. He was encouraged to study at the École Polytechnique, entering in 1802, but he was only barely of the sufficient standard at entry. Nevertheless, within a year he was one of the very best in mathematics, where he attended lectures by Fourier; he graduated from the École des Ponts et Chaussées (bridge and road engineering) as one of the top students in 1806. He undertook field work away from Paris, but returned to teach mechanics at the Ponts in 1819, becoming a professor in 1830.

He specialised in the design of bridges – mainly suspension – but had interests in general engineering, elasticity and fluid mechanics, as well as doing some work on Fourier series (prompted by his continuing friendship with Fourier). It is evident that Navier did not understand the nature of stresses in fluids, but he did have a grasp of the general principles underlying molecular interactions, and used this as the basis to extend Euler’s equation for a fluid. From 1830, he acted as a government adviser on science and technology generally, and on road and rail policy.

**Pitot, Henri (1695-1771)**

Pitot was trained as a hydraulic engineer; he designed the Aqueduc de Saint-Clément (in Montpellier) and the extension of the Pont du Gard (in Nîmes). He became a member of the French Academy of Sciences in 1724 and was elected a foreign member of the Royal Society in 1740.



His hydraulic engineering work led him to study (1832) the flow at various depths in the river Seine – it was thought by many scientists that the speed *increased* with depth – and invented his ‘pitot tube’ to measure the flow speed by using the height of fluid in the pipe. He is also associated with a theorem in plane geometry, relating the two sums of lengths of opposite sides of a quadrilateral that is inscribed by a circle.

**Poiseuille, J.L.M. (1797-1869)**

Poiseuille studied, initially, mathematics and physics at the *École Polytechnique* in Paris (1816), and then obtained a DSc (1828) with a thesis on the flow through the human aorta. Using experiments, he obtained (1838) the relation between pressure gradient and volumetric flow rate through a pipe, assuming that the flow is laminar. (Hagen produced something similar, so both names are often associated with this law.) He formulated this result as a mathematical law – but without relating it in anyway to stresses and viscosity – publishing the results in 1840 and 1846. Throughout his work, he was always striving to understand the flow through narrow tubes, with the aim of applying his observations to flow through veins and arteries. (The unit associated with the coefficient of viscosity, in CGS units, is called the ‘poise’, because ‘poiseuille’ never caught on!)

**Poisson, S.D. (1781-1840)**

The hope of Poisson’s father was that his son would enter the medical profession – it would mean a secure future, but in his studies at the *École Centrale* in Fontainebleau he showed little interest in the relevant topics, and he lacked manual dexterity. However, he learned most other things very quickly, and especially mathematics. He was encouraged to sit the entrance examination for the *École Polytechnique* in Paris; he came top of his year (1798). He studied under Laplace and Legendre, with considerable success (both these teachers remained his friends for life), although he was very poor at geometry: his lack of coordination made it almost impossible for him to draw figures! He was appointed a deputy professor at the *École* in 1802, becoming a full professor in 1806 (replacing Fourier). He was also appointed a professor of mechanics and worked as an astronomer at the *Bureau des Longitudes*.

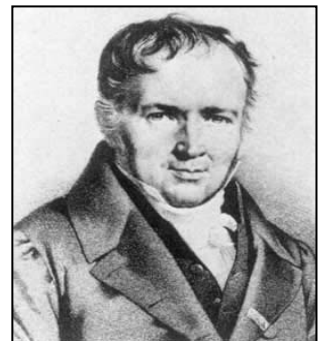

In his early career, he studied various types of differential equation, and their applications e.g. pendulum with resistance, and the theory of sound. He also introduced the technique of series expansions to find approximate solutions to problems related to perturbed planetary orbits. In addition, he worked on problems of heat transfer and the distribution of electrical charge on spheres, on probability theory (developing the notion of random events), on gravitation, on elasticity and stresses. Although he did not, it is argued, develop any very specific, deep, new mathematical results, he introduced many ideas that we use nowadays e.g. Poisson brackets, Poisson’s equation in potential theory, Poisson distribution.

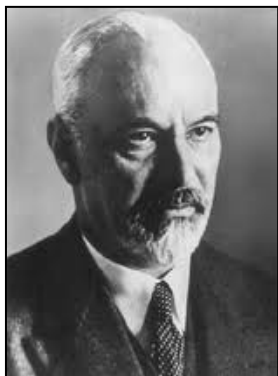
**Prandtl, Ludwig (1875-1953)**

Prandtl was born in Freising, near Munich; he entered the Technische Hochschule in Munich, specialising in solid mechanics, leading to a doctorate (1900), although he had to design a suction pump for some factory equipment – and so got involved in fluid mechanics. He was appointed (1901) a professor of fluid mechanics at what was to become the Technical University of Hannover; this is where he developed most of his important results in aerodynamics and fluid mechanics. In 1904, he delivered a paper on fluid flow with weak friction, in which he introduced the concept of a boundary layer. This was so significant an advance that, later the same year, he was appointed director of the Institute for Technical Physics at Göttingen University, where he remained until his death. Over the next 40 years or so he and his group developed the theory of aerodynamics into the form we use nowadays; he has become known as the ‘father of modern fluid mechanics’. His work was based on a rigorous application of mathematical techniques to the various problems of fluid flow, which laid the basis for the subject as it is currently used and understood.

Following the early work of Lanchester, he introduced various mathematical tools that enabled the prediction of lift (and drag) on realistic, three-dimensional aerofoils, publishing the results towards the end of WWI. In particular, he gave us lifting-line theory and a comprehensive theory of thin aerofoils; the rôle of wing-tip vortices was examined, and induced drag analysed. Between the wars, he moved on to supersonic flow, developing the first theories of shock waves and supersonic flight, including the design of supersonic wind tunnels. He also developed a theory for the corrections to the aerodynamic characteristic, due to compressibility, as the flow speed neared sonic – which was important in the design of aircraft towards the end of WWII, as aircraft speeds increased. Of his many influential students, we should mention Ackeret, Blasius, Busemann, Schlichting, Tollmien, von Kármán.

**Reynolds, Osborne (1842-1912)**

Reynolds was born in Belfast, but soon moved to Dedham (Essex) where his father had been appointed headmaster of the local school there; he was also the Anglican priest in the town. Osborne’s initial education was by private tutoring, and then he took an engineering apprenticeship (1861), but then entered Cambridge University to study mathematics, graduating as seventh in his year (1867). In 1868, he was appointed the first Professor of Engineering at Owens College (which would later (1880) become Manchester University); he remained in this chair until his retirement in 1905.

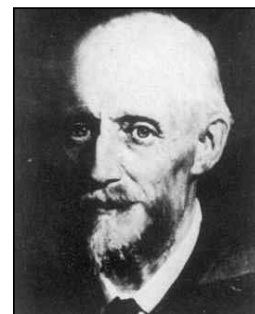

His early work was on various aspects of electricity and magnetism, but he soon transferred his interests to hydraulics and hydrodynamics, and concentrated solely on fluid dynamics after about 1873. In 1883, he announced his observations on the transition from laminar to turbulent flow, introducing at this time his ‘Reynolds’ number. In 1886 he developed a theory of lubrication and, in 1889, an insightful model for turbulent flow.

He was regarded as a man with high standards, which he expected of his engineering students – and such a discipline was then new at university level. He insisted that all these students should have a sound grounding in mathematics, physics and classical mechanics. He developed the applied mathematics course at Manchester, which remains one of the premier such courses in the country.

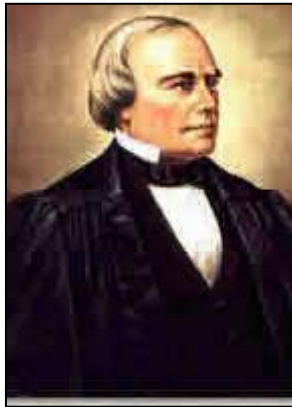
**Robins, Benjamin (1707-1751)**

Benjamin's parents were Quakers and rather poor – his father was a tailor in Bath. There is no record of any formal education, but he must have learnt (for himself) both languages and mathematics; he showed considerable promise, so his parents sent him to be coached in mathematics in London. He was coached by Dr Henry Pemberton who had been impressed by his attempts at exercises that he had been set; Pemberton was, at this time, preparing the third edition of Newton's *Principia*. Robins then read, in English translation, all the classical Greek mathematical texts, as well as all the current mathematical works (Newton, Barrow, Gregory, Fermat, et al.). In 1727, he had begun to publish important extensions of work done, for example, by Newton and Bernoulli; this work was regarded so highly that, in this same year, he was elected a Fellow of the Royal Society.

His fame grew to the extent that he attracted many paying students whom he tutored for Cambridge entry. However, this was not particularly financially-rewarding, so he gradually moved towards engineering, designing bridges, mills and harbours, as well as directing the dredging of rivers (to make them navigable) and draining fens. He also did some important work on gunnery and the design of fortifications. In 1741, the Royal Military Academy (in Woolwich) was founded; Robins failed to get the position of Professor of Fortifications, and so (in 1742) published his *New Principles of Gunnery*, to show the world that he really should have been appointed! This was based on a course that he had hoped to give at the Academy, if he had been appointed; this text soon became the standard work on the theory of artillery and projectiles. Indeed, the text was translated into German (by Euler, who gave it much praise), and into French; it became a standard text for most of mainland Europe. Here, he described his ballistic pendulum (used for the accurate measurement of a projectile's speed), and his work on the motion, including the effects of air resistance, on projectiles fired into the air. Indeed, he introduced the drag law for high-speed motion (proportional to the square of the speed), and recognised the effects of spinning: the Magnus effect.

He was appointed Engineer General with the British East India Company in 1749, and was sent to India the next year; he died after contracting a severe fever.

**Saint-Venant, A.J.C.B. de (1797-1886)**

Saint-Venant was a student at the École Polytechnique, in Paris, from 1813-1816, and then worked as civil engineer, first for the Service des Poudres et Salpêtres (until 1823), and then for the Service des Ponts et Chaussées (until 1843). Throughout this period, he worked on various mathematical problems, but did not publish them (although he referred to many of them later, when disputes arose, and he certainly used much of his own material when he taught); his main interests were in mechanics, elasticity and hydrodynamics. He studied at the Collège de France, attending classes given by Liouville, and then taught at École des Ponts et Chaussées; he was elected to the Académie des Sciences in 1868.

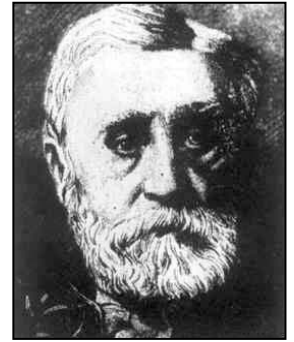

His most significant work was published in 1843, where he gave a derivation of the Navier-Stokes equation based on fluid stresses – two years before Stokes gave a similar analysis – making Navier’s work more mathematically correct. It is rather surprising that Saint-Venant’s name is not associated with this fundamental equation, although it is often called the Saint-Venant equation in France. He also worked on the analysis of stress in solid bodies, giving the complete solution for torsion in non-circular cylinders, and extending work on the bending of beams. One of the mathematical tools that he invented and developed was a version of the vector calculus.

## Do you have to be a banker to **work** in investment banking?

**Deutsche Bank**  
[db.com/careers](https://www.db.com/careers)

---

Agile minds **value ideas** as well as experience

---

### Global Graduate Programs

Ours is a complex, fast-moving, global business. There’s no time for traditional thinking, and no space for complacency. Instead, we believe that success comes from many perspectives — and that an inclusive workforce goes hand in hand with delivering innovative solutions for our clients. It’s why we employ 135 different nationalities. It’s why we’ve taken proactive steps to increase female representation at the highest levels. And it’s just one of the reasons why you’ll find the working culture here so refreshing.

Discover something different at [db.com/careers](https://www.db.com/careers)

Passion to Perform





**Stokes, G.G. (1819-1903)**

Stokes was the youngest of six children; his father was the protestant minister in Skreen (County Sligo, Ireland), who ensured that all his children had a religious and general education. In 1832 he was sent to Dublin, where he attended school (but not as a boarder – the family were too poor for that to be possible, so he lived with an uncle). At the age of 16 he then moved to England, studying at Bristol College for two years prior to entering Cambridge University in 1837 where he was tutored by William Hopkins (one of the most famous tutors at the time). Stokes went on to graduate the top of all mathematicians (Senior Wrangler) in 1841 and, following the advice of Hopkins, he decided to work on hydrodynamics at Pembroke College where he was immediately given a fellowship.

He worked, initially, on the general form of incompressible flow (1842-1843) and then embarked (1845) on the analysis of viscous flow, producing the now-accepted complete and comprehensive derivation of the Navier-Stokes equation (two years after Saint-Venant had achieved the same!). He developed this work on fluids, in conjunction with studies on the aberration of light, on the motion of pendulums (in fluids) and on aspects of geodesy; he was appointed Lucasian Professor of Mathematics at Cambridge – Newton's chair – in 1849. This post, however, was poorly paid, so he also took up the chair of Professor of Physics at the School of Mines in London (which was to become, eventually, one of the three founding schools of Imperial College). He continued to produce fundamental results in fluid mechanics (e.g. the resistance of flow past small spheres) and on the wave theory of light, as well as explaining (and naming) the phenomenon of fluorescence, and analysing Fraunhofer lines in the solar spectrum.

After 1857, he became much involved in administration; he was appointed secretary to the Royal Society (1854) and the President (1885), Master of Pembroke College in 1902, and served as the MP for Cambridge University 1887-1892.

**von Kármán, Theodore (1881-1963)**

Theodore was born in Budapest, and was tutored at home by a former student of his father – and his father totally dominated the home and his education. When he was 9, he entered the Minta Gymnasium, in Budapest, a school set-up by his father and run according to his principles for educating bright children. On completion of his studies, he won a prize as the best mathematics and science student in all of Hungary. However, his father insisted that he study engineering, and so, much as he hated it, he completed his studies in mechanical engineering at the Palatine Joseph Polytechnic in Budapest. (His father had a nervous breakdown while he was at the polytechnic, but Theodore went on to complete the course.) In 1903 he was appointed as an assistant in hydraulics at his old polytechnic, but he was also a consultant for a German locomotive manufacturer.

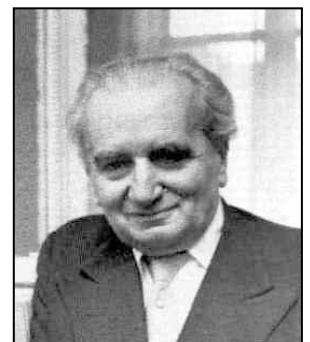

His interests, at this time, circulated around fluids in general, and also on the compression of structures. In 1906, he received a fellowship that allowed him to follow-up his contacts in Germany: he studied at Göttingen (and for a short while in Paris), where he was introduced to the problems of flight. However, he first worked on the buckling of plates, and received his doctorate for this in 1908; then he joined the staff at Göttingen. In 1911, he analysed the flow behind a bluff body – the von Kármán street vortex – and also (with Max Born) looked at the properties of vibrating atoms. In 1913 he accepted the post of director of the Aeronautical Institute at Aachen, and the Chair of Aeronautics and Mechanics at Aachen University. During WWI, when he was called-up by the Austro-Hungarian army, he worked on the design of military aircraft; after the war, he returned to Aachen. He then initiated an extensive programme to study general fluid flows, and especially resistance, turbulence and the theory of lift generation.

He visited the USA regularly from about 1926, and in 1930 he was invited to be the director of the Aeronautical Laboratory at Caltech, where he continued his research, expanding into the theories of supersonic flight. In 1944, he was also appointed director of the Jet Propulsion Laboratory at Caltech, which eventually made significant contributions to the American space programme.

### Wright, Wilbur (1867-1912) and Orville (1871-1948)



The Wright brothers invented, and flew, the first controlled and powered aircraft; indeed, from the outset, their aim was to construct a craft that would carry a human and be reliably controllable by the pilot. Their father was of English-Dutch descent – their mother was German-Swiss – and a bishop in the Church of the United Brethren in Christ, first in Millville (Indiana) and then in Dayton, Ohio. Wilbur was born in Millville, and Orville in Dayton, but Wilbur was barely able to finish his high-school education before the sudden move to Ohio in 1884; Orville dropped out of school. A further complication to their lives was the injury to Wilbur (accidental during a game of ice hockey) which made him housebound for about four years, during which time he cared for his mother who was terminally ill with TB.

However, Orville soon set up a printing business (1889), using a printing press designed and built with the help of Wilbur – this occupation helped him to overcome the depression following his accident. They edited and published a number of local newspapers, with some success. They then joined the new bicycle craze, opening a bicycle repair and sales shop (1892), and then manufacturing and selling their own design of bicycle (1896). This venture was so successful that they were able to use the funds generated to support their aeronautical investigations. They followed the flights of Lilienthal, through the news reports, and it seems that his death was one of the main events that spurred their aim to construct a controllable aircraft. In 1899, Wilbur wrote to the Smithsonian Institute requesting all the relevant background information (describing the work of, for example, Cayley, Chanute and Lilienthal). They first followed Lilienthal, despite his tragic death using hang-gliders, by designing and building gliders in order to learn how to control flight safely. Throughout their approach to solving the ultimate problem of manned flight, they were absolutely systematic and thorough.

The first task they addressed was where to carry out their flight tests. With the advice of Chanute (from France), and the weather data they had obtained from the US Weather Bureau, with specific information from the government meteorologist stationed at Kitty Hawk (North Carolina), they chose this location. They made numerous glider flights – many unmanned – during 1901-1903, gradually perfecting the control system. The manned flights, which the two brothers shared so that each would learn the relevant skills, involved the pilot laying prone across the lower wing – all their craft were biplanes – in the centre. Eventually they realised the need, when turning, to require differential lift on the wings, which they accomplished by twisting (wing warping); this is equivalent to the modern ailerons. But this alone produced a differential drag that caused the glider to rotate about a vertical axis, changing the direction of travel. So they added a fixed vertical tail, but then the glider would often not level off, and gradually slide sideways into the ground. The solution, they found – and this was their most important discovery – was to move the tail (making it a rudder) and then to hinge the rudder to the warping. In short, they had discovered that directional control was provided by the wing warping (the ailerons), and the moveable rudder ensured the correct alignment of the aircraft in the turn and when straightening up.

**Real drive.  
Unreal destination.**

As an intern, you're eager to put what you've learned to the test. At Ernst & Young, you'll have the perfect testing ground. There are plenty of real work challenges. Along with real-time feedback from mentors and leaders. You'll also get to test what you learn. Even better, you'll get experience to learn where your career may lead. Visit [ey.com/internships](http://ey.com/internships).

[See More | Opportunities](#)

© 2012 Ernst & Young LLP. All Rights Reserved.

**ERNST & YOUNG**  
Quality In Everything We Do



In addition to this fundamental breakthrough, they found that the data on aerofoil shapes, and the lift that they generated, was not sufficiently accurate or reliable, so they built a small wind tunnel (about 2m long) and, towards the end of 1901, conducted numerous, systematic tests on miniature wings and aerofoil shapes. They were able, by balancing forces, to measure both the lift and the drag of their models. Furthermore, they also designed, built and tested various types of wooden propeller. Finally, they needed a suitable engine to drive the propellers; they contacted several engine manufacturers, but none were able to produce the light-weight engine, with sufficient power, that they required. So, with the help of their shop mechanic (Charlie Taylor), they designed and built – in six weeks – an engine that satisfied their requirements. (Very unusually, the engine block was cast from aluminium – to keep the weight down – which in itself was a novel feature.) The resulting complete *Wright Flyer* (later *I*) had a wing span of 12.3m, weighed 274kg, with a 12-horsepower engine weighing 82kg.



They commenced flight testing on 14 December 1903, at Kill Devil Hills (at the edge of the Kitty Hawk area), but their inexperience led to some stalling and minor damage. They had tossed a coin to decide who was to pilot the aircraft first, and so it fell to Orville to make the first successful flight (37m and 12 secs) on 17 December; this was followed, on the same day by Wilbur (53m) and then Orville (61m). The final flight of the day was by Wilbur (252m and 59secs). After that, they made many improvements, and learnt much about how to pilot their craft, so that by November 1904, the *Wright Flyer II* had flown 536m in 40secs, and the *Wright Flyer III* flew 20 miles, staying aloft for 1/2 hour, in October 1905.

The brothers contacted the US government, and then those of Britain, France and Germany, with the aim of selling the idea – and an aircraft – to them, but nothing came of it. (The reason appears to be that the Wrights insisted on a signed contract before any demonstration flights had been made!) They did no flying in 1906-1907, as they negotiated with the US and European governments, but in May 1906 they were granted a US patent for their flying machine. This led, in 1909, to the completion of proving flights for the US Army; they demonstrated a two-seater aircraft that flew for an hour at a speed of 64km/h (and landed undamaged!). Their craft exceeded the required specification; they sold an aircraft for \$30,000. By the end of 1909, they had formed the Wright Company, and then they sold their patents for \$100,000, and received one third of the shares in a million-dollar stock issue, and a 10% royalty on every aircraft sold. (In 1910, they redesigned the Flyer, so that the horizontal elevator was at the rear, and wheels were added, although the skids were retained.)

Wilbur died in 1912, after contracting typhoid following a trip to Boston. Orville continued as president of the Wright Company until 1915, when he sold it, moving to a grand mansion in Oakwood, Ohio. He died in 1948; he had been instrumental in the development of controlled, powered flight, and lived to see the dawn of the supersonic age.



The next step for top-performing graduates

**Masters in Management**

Designed for high-achieving graduates across all disciplines, London Business School's Masters in Management provides specific and tangible foundations for a successful career in business.

This 12-month, full-time programme is a business qualification with impact. In 2010, our MiM employment rate was 95% within 3 months of graduation\*; the majority of graduates choosing to work in consulting or financial services.

As well as a renowned qualification from a world-class business school, you also gain access to the School's network of more than 34,000 global alumni – a community that offers support and opportunities throughout your career.

For more information visit [www.london.edu/mm](http://www.london.edu/mm), email [mim@london.edu](mailto:mim@london.edu) or give us a call on **+44 (0)20 7000 7573**.

\* Figures taken from London Business School's Masters in Management 2010 employment report



## Appendix 2: Check-list of basic equations

Coordinates

*Cartesian* :  $\mathbf{x} \equiv (x, y, z)$ ,  $\mathbf{u} \equiv (u, v, w)$ ;

*Cylindrical polars* :  $\mathbf{x} \equiv (r, \theta, z)$ ,  $\mathbf{u} \equiv (u, v, w)$ .

Mass conservation (incomp.)

$$\nabla \cdot \mathbf{u} = 0: \frac{\partial u}{\partial x} + \frac{\partial v}{\partial y} + \frac{\partial w}{\partial z} = 0;$$

$$\frac{1}{r} \frac{\partial}{\partial r}(ru) + \frac{1}{r} \frac{\partial v}{\partial \theta} + \frac{\partial w}{\partial z} = 0.$$

Euler's equation

$$\frac{D\mathbf{u}}{Dt} = \left( \frac{\partial}{\partial t} + \mathbf{u} \cdot \nabla \right) \mathbf{u} = \left( \frac{\partial}{\partial t} + u \frac{\partial}{\partial x} + v \frac{\partial}{\partial y} + w \frac{\partial}{\partial z} \right) \mathbf{u} = -\frac{1}{\rho} \nabla p + \mathbf{F}$$

i.e.  $\left( \frac{\partial}{\partial t} + u \frac{\partial}{\partial x} + v \frac{\partial}{\partial y} + w \frac{\partial}{\partial z} \right) (u, v, w) = -\frac{1}{\rho} \left( \frac{\partial p}{\partial x}, \frac{\partial p}{\partial y}, \frac{\partial p}{\partial z} \right) + (F_x, F_y, F_z)$

and

$$\left( \frac{\partial}{\partial t} + u \frac{\partial}{\partial r} + \frac{v}{r} \frac{\partial}{\partial \theta} + w \frac{\partial}{\partial z} \right) (u, v, w) + \left( -\frac{v^2}{r}, \frac{uv}{r}, 0 \right) = -\frac{1}{\rho} \left( \frac{\partial p}{\partial r}, \frac{1}{r} \frac{\partial p}{\partial \theta}, \frac{\partial p}{\partial z} \right) + (F_r, F_\theta, F_z)$$

Navier-Stokes equation

$$\frac{D\mathbf{u}}{Dt} = -\frac{1}{\rho} \nabla p + \nu \nabla^2 \mathbf{u} + \mathbf{F}$$

Bernoulli's equation

$$\frac{1}{2} \mathbf{u} \cdot \mathbf{u} + \int \frac{dp}{\rho} + \Omega = \text{constant on streamlines};$$

Laplace's equation

$$\nabla^2 \phi = 0: \frac{\partial^2 \phi}{\partial x^2} + \frac{\partial^2 \phi}{\partial y^2} + \frac{\partial^2 \phi}{\partial z^2} = 0;$$

$$\frac{\partial^2 \phi}{\partial r^2} + \frac{1}{r} \frac{\partial \phi}{\partial r} + \frac{1}{r^2} \frac{\partial^2 \phi}{\partial \theta^2} + \frac{\partial^2 \phi}{\partial z^2} = 0.$$

**Velocity potential**

$$\mathbf{u} = \nabla\phi : \quad \nabla\phi \equiv \left( \frac{\partial\phi}{\partial x}, \frac{\partial\phi}{\partial y}, \frac{\partial\phi}{\partial z} \right) ; \quad \nabla\phi \equiv \left( \frac{\partial\phi}{\partial r}, \frac{1}{r} \frac{\partial\phi}{\partial\theta}, \frac{\partial\phi}{\partial z} \right).$$

**Pressure equation**

$$\frac{\partial\phi}{\partial t} + \frac{1}{2} \mathbf{u} \cdot \mathbf{u} + \int \frac{dp}{\rho} + \Omega = f(t) \text{ for irrotational flow.}$$

**Stream function**

$$u_x + v_y = 0 : u = \psi_y, v = -\psi_x ;$$

$$\frac{1}{r} (ru)_r + \frac{1}{r} v_\theta = 0 : u = \frac{1}{r} \psi_\theta, v = -\psi_r .$$

**Vorticity ( $\boldsymbol{\omega} = \nabla \wedge \mathbf{u}$ )**

$$\boldsymbol{\omega} = (w_y - v_z, u_z - w_x, v_x - u_y)$$

$$\boldsymbol{\omega} \equiv \left( \frac{1}{r} w_\theta - v_z, u_z - w_r, \frac{1}{r} (rv)_r - \frac{1}{r} u_\theta \right)$$

**Blasius' theorem**

$$\text{for forces : } X - iY = \frac{1}{2} i \rho \oint_C \left( \frac{dw}{dz} \right)^2 dz ;$$

$$\text{for moments : } M = \Re \left\{ -\frac{1}{2} \rho \oint_C z \left( \frac{dw}{dz} \right)^2 dz \right\}.$$

### Appendix 3: Derivation of Euler's equation (which describes an inviscid fluid)

This handout describes how we apply, in a mathematically careful way, Newton's Second Law to a fluid. In this model we take the fluid to be acted on by a body force  $\mathbf{F}$  (per unit mass) and by a pressure,  $p$ , the only internal force (so the fluid is assumed to be inviscid i.e. it is frictionless).

We consider an (imaginary) volume  $V$ , with a bounding surface  $S$  (and outward unit normal  $\mathbf{n}$ ), which is *fixed* in our chosen coordinate system and totally occupied by fluid; the fluid therefore, in general, moves across  $S$ , into and out of the volume  $V$ .

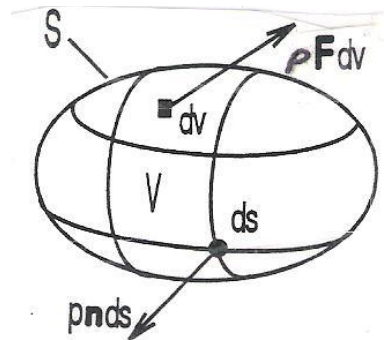

STEP INTO A WORLD  
OF OPPORTUNITY

[www.ecco.com/trainees](http://www.ecco.com/trainees)  
[trainees@ecco.com](mailto:trainees@ecco.com)











The total force acting *on* the fluid in  $V$  (see §1.5) is

$$\int_V (\rho \mathbf{F} - \nabla p) dv.$$

To apply Newton's Second Law we must first appreciate that, simply because the fluid is in motion, fluid may cross  $S$  and enter  $V$ , thereby carrying momentum into  $V$ . If we compute the rate of change of momentum of the fluid in  $V$  (that is, the more correct statement of 'mass  $\times$  acceleration'), and subtract the rate of change of momentum contributed by the fluid entering  $V$ , any residual rate of change of momentum can come about due only to the action of forces.

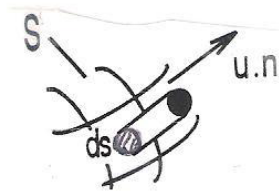
The rate of flow of momentum *into*  $V$  across  $S$  is



$$-\int_S \rho \mathbf{u} (\mathbf{u} \cdot \mathbf{n}) ds,$$

since  $\mathbf{u} \cdot \mathbf{n} \Delta S$  is the volume flow (out) per unit time, and the mass flux this carries is  $\rho \mathbf{u}$ , the product being the momentum carried out; the change of sign then provides the momentum crossing *into*  $V$ .

The total momentum of the fluid in  $V$  at any instant is

$$\int_V \rho \mathbf{u} dv$$

and so the rate of change of momentum is therefore

$$\begin{aligned} \frac{d}{dt} \int_V \rho \mathbf{u} dv \\ = \int_V \frac{\partial}{\partial t} (\rho \mathbf{u}) dv \end{aligned}$$

since  $V$  is *fixed* in our coordinate system.

Thus Newton's Second Law is written

$$\int_V \frac{\partial}{\partial t} (\rho \mathbf{u}) dv + \int_S \rho \mathbf{u} (\mathbf{u} \cdot \mathbf{n}) ds = \int_V (\rho \mathbf{F} - \nabla p) dv. \quad (*)$$

This equation is now expressed as a single integral over  $V$ , and so we first write

$$\int_S \rho \mathbf{u}(\mathbf{u} \cdot \mathbf{n}) ds = \left( \int_S \rho u(\mathbf{u} \cdot \mathbf{n}) ds, \dots, \dots \right), \text{ that is, in component form.}$$

Then, by Gauss' theorem, we have for the first component :

$$\int_S \rho u(\mathbf{u} \cdot \mathbf{n}) ds = \int_S (\rho u \mathbf{u}) \cdot \mathbf{n} ds = \int_V \nabla \cdot (\rho u \mathbf{u}) dv = \int_V \{u \nabla \cdot (\rho \mathbf{u}) + \rho(\mathbf{u} \cdot \nabla)u\} dv,$$

and similarly for the other two components. (Do not confuse the velocity vector,  $\mathbf{u}$ , with the first component of this vector,  $u$ .)

Recombining the three components, we obtain

$$\int_S \rho \mathbf{u}(\mathbf{u} \cdot \mathbf{n}) ds = \int_V \{\mathbf{u} \nabla \cdot (\rho \mathbf{u}) + \rho(\mathbf{u} \cdot \nabla)\mathbf{u}\} dv.$$

The full equation (\*) now reads

$$\int_V \left\{ \frac{\partial}{\partial t}(\rho \mathbf{u}) + \mathbf{u} \nabla \cdot (\rho \mathbf{u}) + \rho(\mathbf{u} \cdot \nabla)\mathbf{u} \right\} dv = \int_V (\rho \mathbf{F} - \nabla p) dv,$$

and expanding the integrand on the left hand side yields

$$\int_V \left\{ \rho \frac{\partial \mathbf{u}}{\partial t} + \mathbf{u} \frac{\partial \rho}{\partial t} + \mathbf{u} \nabla \cdot (\rho \mathbf{u}) + \rho(\mathbf{u} \cdot \nabla)\mathbf{u} \right\} dv.$$

The second and third terms inside this integral are  $\mathbf{u} \left\{ \frac{\partial \rho}{\partial t} + \nabla \cdot (\rho \mathbf{u}) \right\} = \mathbf{0}$ , by virtue of the equation of mass conservation. Thus we are left with

$$\int_V \left\{ \rho \frac{\partial \mathbf{u}}{\partial t} + \rho(\mathbf{u} \cdot \nabla)\mathbf{u} - \rho \mathbf{F} + \nabla p \right\} dv = \int_V \left\{ \rho \frac{D\mathbf{u}}{Dt} - \rho \mathbf{F} + \nabla p \right\} dv = 0,$$

where we have introduced the material derivative.

Finally, if this is to be valid for *arbitrary*  $V$ s that contain fluid, then we require

$$\rho \frac{D\mathbf{u}}{Dt} - \rho \mathbf{F} + \nabla p = \mathbf{0} \quad \text{or} \quad \frac{D\mathbf{u}}{Dt} = -\frac{1}{\rho} \nabla p + \mathbf{F},$$

as we developed in a rather cavalier fashion in §1.6. This final equation is Euler's equation, which describes the motion of an inviscid fluid.

#### Appendix 4: Kelvin's circulation theorem (1869)

The circulation is defined by  $K(t) = \oint_C \mathbf{u} \cdot d\mathbf{l}$ ; the simple closed curve  $C$  is defined by the points  $\mathbf{x} = \mathbf{X}(s, t)$ , where  $0 \leq s \leq S_0$  maps out  $C$  (just once) and  $S_0$  is a constant.

Thus we have

$$K(t) = \int_0^{S_0} \mathbf{u}(\mathbf{X}(s, t), t) \cdot \frac{\partial \mathbf{X}}{\partial s} ds,$$

and now we take  $d/dt$  of this equation to give

$$\frac{dK}{dt} = \int_0^{S_0} \left\{ \left[ \frac{\partial \mathbf{u}}{\partial t} + \left( \frac{\partial \mathbf{X}}{\partial t} \cdot \nabla \right) \mathbf{u} \right] \cdot \frac{\partial \mathbf{X}}{\partial s} + \mathbf{u} \cdot \frac{\partial^2 \mathbf{X}}{\partial s \partial t} \right\} ds.$$

But the curve  $C$  moves with the fluid, so  $\frac{\partial \mathbf{X}}{\partial t} = \mathbf{u}(\mathbf{X}, t)$ ; thus we obtain

$$\begin{aligned} \frac{dK}{dt} &= \int_0^{S_0} \left\{ \left( \frac{\partial \mathbf{u}}{\partial t} + (\mathbf{u} \cdot \nabla) \mathbf{u} \right) \cdot \frac{\partial \mathbf{X}}{\partial s} + \mathbf{u} \cdot \frac{\partial \mathbf{u}}{\partial s} \right\} ds \\ &= \int_0^{S_0} \left( \frac{D\mathbf{u}}{Dt} \cdot \frac{\partial \mathbf{X}}{\partial s} + \mathbf{u} \cdot \frac{\partial \mathbf{u}}{\partial s} \right) ds. \end{aligned}$$

Further, if  $\mathbf{F}$  is conservative and the fluid has either  $\rho = \text{constant}$  or is barotropic (i.e.  $p = p(\rho)$ ), then the material-derivative term can be replaced (Euler's equation) to give

$$\begin{aligned} \frac{dK}{dt} &= \int_0^{S_0} \left\{ -\frac{\partial \mathbf{X}}{\partial s} \cdot \nabla \left( \int \frac{dp}{\rho} + \Omega \right) + \mathbf{u} \cdot \frac{\partial \mathbf{u}}{\partial s} \right\} ds \\ &= \int_0^{S_0} \left\{ -\frac{\partial}{\partial s} \left( \int \frac{dp}{\rho} + \Omega \right) + \frac{\partial}{\partial s} \left( \frac{1}{2} \mathbf{u} \cdot \mathbf{u} \right) \right\} ds = \left[ -\left( \int \frac{dp}{\rho} + \Omega \right) + \frac{1}{2} \mathbf{u} \cdot \mathbf{u} \right]_0^{S_0} \\ &= 0 \end{aligned}$$

if all these functions are single-valued in space (which is certainly the case for a physically realistic flow).

Thus  $K = \text{constant}$  around any simple closed contour that moves with the fluid; this turns out to be a result with far-reaching consequences, some of which we shall meet when we consider aerofoil theory.

Appendix 5: Some Joukowski aerofoils

Using  $z = \zeta + \frac{1}{\zeta}$  with  $\zeta = c + re^{i\theta}$  where  $|a - c| = r$  and  $c = -a + ib$ .

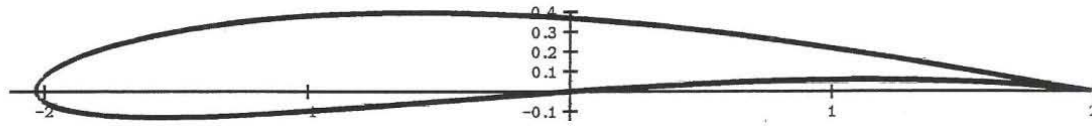

$a = 0.1 \quad b = 0.1$

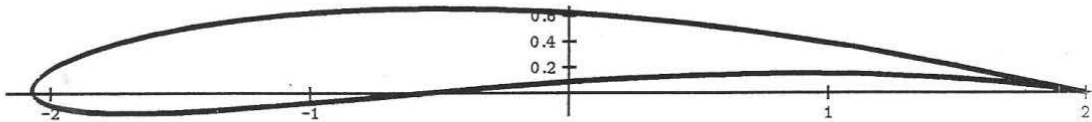

$a = 0.15 \quad b = 0.2$

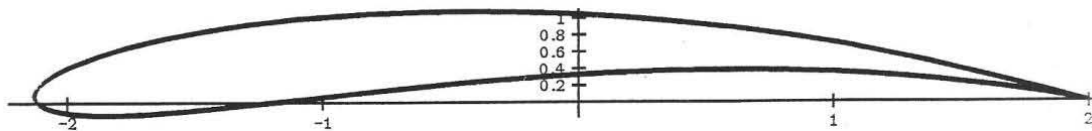

$a = 0.2 \quad b = 0.4$

## Appendix 6: Lift on a flat-plate aerofoil

The force, according to the Blasius Theorem for forces, is

$$\begin{aligned} X - iY &= \frac{1}{2} i\rho \oint_{\text{aerofoil}} \left( \frac{dw}{dz} \right)^2 dz \\ &= \frac{1}{2} i\rho \oint_{\text{aerofoil}} \left( \frac{dW}{d\zeta} \frac{d\zeta}{dz} \right)^2 dz = \frac{1}{2} i\rho \oint_{\text{circle}} \frac{(dW/d\zeta)^2}{(dz/d\zeta)} d\zeta. \end{aligned}$$

Now the integrand here is

$$\frac{\left[ Ue^{-i\alpha} - Ue^{i\alpha} \frac{a^2}{\zeta^2} + \frac{iK}{2\pi} \frac{1}{\zeta} \right]^2}{1 - a^2/\zeta^2} = \frac{\zeta^2 \left[ Ue^{-i\alpha} - Ue^{i\alpha} \frac{a^2}{\zeta^2} + \frac{iK}{2\pi} \frac{1}{\zeta} \right]^2}{(\zeta - a)(\zeta + a)}$$

which has poles at  $\zeta = 0, \pm a$ ; because there are no other poles, we may use any contour exterior to the plate (which is equivalent to taking a contour in the region where the fluid exists, just around the plate, for example – precisely what we need in order to find the force on the plate). The pole at  $\zeta = 0$  is an intrinsic element of this problem; the one at  $\zeta = a$  is accommodated by the Kutta condition i.e. the fluid velocities near here remain finite; the third one, at  $\zeta = -a$ , is not removable and so may imply that this special aerofoil cannot lead to a meaningful result. (Note that the aerofoils of interest have a rounded nose, so this singularity does not arise.) Let us evaluate this integral directly.

Based on the integrand, and using  $K = 4\pi aU \sin \alpha$ :

$$\text{the residue at } \zeta = 0 \text{ is } -2a^2 U e^{i\alpha} \frac{iK}{2\pi} \left( -\frac{1}{a^2} \right) = \frac{iUK e^{i\alpha}}{\pi} = i4aU^2 e^{i\alpha} \sin \alpha;$$

the residue at  $\zeta = a$  is

$$\frac{a^2}{2a} \left[ U(-2i \sin \alpha) + \frac{i}{2\pi a} K \right]^2 = \frac{a}{2} [-2iU \sin \alpha + 2iU \sin \alpha]^2 = 0;$$

$$\text{the residue at } \zeta = -a \text{ is } \frac{a^2}{-2a} \left[ U(-2i \sin \alpha) - \frac{i}{2\pi a} K \right]^2 = -\frac{a}{2} [-4iU \sin \alpha]^2.$$

Thus the complex force becomes

$$\begin{aligned} X - iY &= \frac{1}{2} i\rho \times 2\pi i \times \left[ 4iaU^2 e^{i\alpha} \sin \alpha + \frac{a}{2} 16U^2 \sin^2 \alpha \right] \\ &= -4\pi\rho a U^2 \left( i e^{i\alpha} \sin \alpha \cos \alpha + 2 \sin^2 \alpha \right) \\ &= -4\pi\rho a U^2 \left( \sin^2 \alpha + i \sin \alpha \cos \alpha \right), \end{aligned}$$

and so  $X = -4\pi a \rho U^2 \sin^2 \alpha$  and  $Y = 4\pi a \rho U^2 \sin \alpha \cos \alpha$ .

These are the components of the force  $4\pi a \rho U^2 \sin \alpha$  at right angles to the oncoming stream, precisely according to the Kutta-Joukowski: the flow at infinity in each plane is the same, as is the logarithmic singularity: the vortex of strength  $-K$ .

#### Comment

Because we may use any contour outside the flat plate – there are no other poles in the flow field – we may take the contour to be that approaching infinity:  $|\zeta| \rightarrow \infty$ . In this case, the integrand is written

$$\left[ Ue^{-i\alpha} - Ue^{i\alpha} \frac{a^2}{\zeta^2} + \frac{iK}{2\pi\zeta} \right]^2 \left( 1 - \frac{a^2}{\zeta^2} \right)^{-2} \quad \text{with } |\zeta| \rightarrow \infty,$$

and then the coefficient of the term  $\zeta^{-1}$  is  $2Ue^{-i\alpha} \frac{iK}{2\pi}$ . Thus we obtain

$$X - iY = \frac{1}{2} i\rho \times 2\pi i \times iUe^{-i\alpha} 4aU \sin \alpha = -4\pi a \rho U^2 (\sin^2 \alpha + i \sin \alpha \cos \alpha)$$

exactly as above.

## Appendix 7: MAPLE program for plotting Joukowski aerofoils

This Maple program generates the streamlines for the complex potential flow which represents the uniform stream past a Joukowski aerofoil with circulation. The circle has centre  $z_0$  and radius  $c$ , and  $z_0$  can be chosen by selecting  $a$  and  $b$ ; you may investigate the effect of changing  $a$  and  $b$ . The circulation is  $k$ , and the program selects this to ensure that the velocity at the trailing edge ( $ut$ ) is finite.

You may wish to interpret the program, and relate it to the theory of the Joukowski aerofoil and the flow around it.

```
> with(plots, contourplot, display) :
> readlib(addcoords) (z_cylindrical, [z, r, theta], [r*cos(theta), r*sin(theta), z]);
> ut:=1.0+0.2*I:c:=1.0:a:=0.9:b:=0.1:
> z0:=-c+a+I*b:ubar:=conjugate(ut) :
> alpha:=arcsin(b/c) :argu:=argument(ut) :
> k:=2.0*abs(ut)*c*sin(alpha+argu) :
> w:=proc(zi) ubar*zi+ut*c*c/zi+I*k*ln(zi/c) end:
> f:=proc(zi) zi+a*a/zi end:
> g:=proc(z) 0.5*z*(1.0+sqrt(1.0-4.0*a*a/(z*z))) end:
> flow:=contourplot( evalf(Im(w(g(r*exp(I*theta))-z0))), r=0.2..4, theta=0..2*Pi, coords=z_cylindrical, grid=[60, 60], contours=16, color=black) :
> wing:=plot([evalf(Re(f(z0+c*exp(I*t))))], evalf(Im(f(z0+c*exp(I*t))))], t=-Pi..Pi, x=-4..4, y=-4..4, color=black) :
> display({flow, wing}, title='Flow past Joukowski aerofoil with
circulation')
```



We are experts in emulsifiers and stabilizers for:

- bakery
- confectionery
- dairy
- ice cream
- margarine
- fine foods

and we are constantly looking for new “heart-working” colleagues who are passionate and dedicated to helping food companies around the world develop new and innovating products.

## Emulsifiers and stabilizers

Visit [www.palsgaard.com](http://www.palsgaard.com) to find out more about a career at Palsgaard HQ in Denmark or in one of our 11 subsidiaries around the world.

**Palsgaard®**  
Heart working people

Palsgaard A/S  
DK-7130 Juelsminde, Denmark  
Phone +45 76 82 76 82  
direct@palsgaard.dk



# Answers

All the exercises are numbered sequentially throughout the text. Any calculation that leads to an answer that is not provided in the question is given below; all other details are omitted. (We adopt the notation that  $A, B, \dots$  are arbitrary constants.)

1. (a)  $T = \frac{k}{R} \rho^{\gamma-1}$ ; (b)  $T = \frac{k^{1/\gamma}}{R} p^{1-1/\gamma}$ .

2. (a)  $T = \frac{1}{R} (k \rho^{\gamma-1} + a \rho) (1 - b \rho)$ ;

(b)  $T = \frac{1}{R} (k^{1/\gamma} p^{1-1/\gamma} + a k^{-1/\gamma} p^{1/\gamma}) (1 - b k^{-1/\gamma} p^{1/\gamma})$ .

3.  $p \approx \rho RT + (bRT - a) \rho^2$ . 4.  $k = RT$ .

5. (a)  $y = Ax^2$ ; (b)  $x^2 + 4y^2 = A$ ; (c)  $xy = A$ ; (d)  $xy^t = A$ .

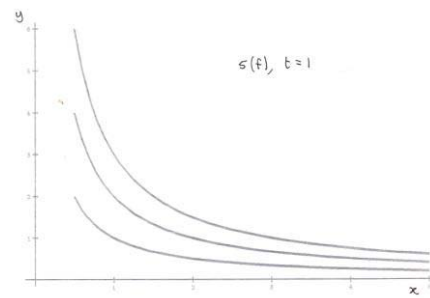
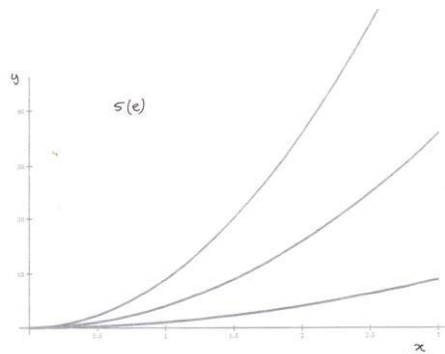

6. (a)  $x = x_0 e^{at}$ ,  $y = y_0 e^{2at}$ ;

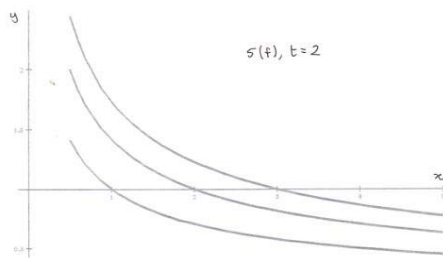

(b)  $x = \cos(2at) - 2 \sin(2at)$ ,  $y = \cos(2at) + \frac{1}{2} \sin(2at)$ ;

(c)  $x = x_0 e^{t^2/2}$ ,  $y = y_0 e^{-t^2/2}$ ;

(d)  $x = x_0 e^{\frac{1}{2}(t^2-1)}$ ,  $y = y_0 e^{1-t}$ .

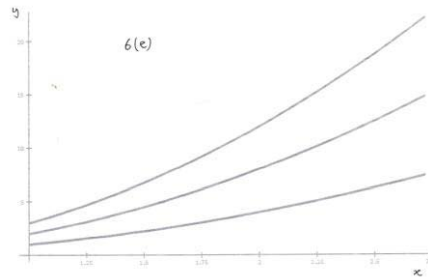
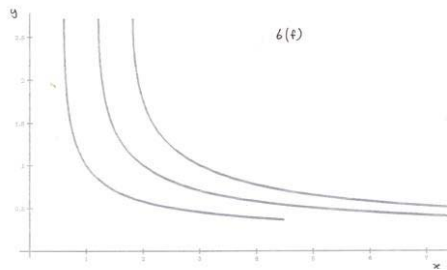

10. (b)  $4 \sin(16x^2) - 3 \sin(9x^2)$ ; (c)  $R^3 \left( R' + \frac{1}{4} R \right) e^{-z^2}$ .

12. (a)  $xy = A$ ,  $x = x_0 e^{kt}$ ,  $y = y_0 e^{-kt}$ ,  $z = z_0$ ;

(b)  $xy = A$ ,  $x = x_0 e^{t^2}$ ,  $y = y_0 e^{-t^2}$ ,  $z = z_0$ ;

(c)  $y(x-t) = A$ ,  $x = 1+t + (x_0-1)e^t$ ,  $y = y_0 e^{-t}$ ,  $z = z_0$ ;

(d)  $xy^t = A$ ,  $x = x_0 e^{\frac{1}{2}t^2}$ ,  $y = y_0 e^{-t}$ ,  $z = z_0$ ;

(e)  $xy^2 = A$ ,  $x = At^2$ ,  $yt = B$  (cannot use condition on  $t = 0$ );

(f)  $x^4 = Ae^{y^4/t^2}$ ,  $x = At^2 y_0^2 e^{\frac{1}{2}t^2}$ ,  $y^2 = y_0^2 + t^2$ ,  $z = z_0$  (cannot use the given condition on  $x$  at  $t = 0$ );

(g)  $x^2 + y^2 = 2ctx + A$ ,  $x = x_0 \cos(kt) + (y_0 - c/k) \sin(kt)$ ,

$y = -x_0 \sin(kt) + (y_0 - c/k) \cos(kt) + c/k$ ,  $z = z_0$ ;

(h)  $y = \frac{x}{1+Ax}$ ,  $z = B \frac{(1+Ax)^2}{x^4}$ ,  $x = \frac{x_0}{1-kx_0t}$ ,  $y = \frac{y_0}{1-ky_0t}$ ,  $z = z_0(1-kx_0t)^2(1-ky_0t)^2$ ;

(i)  $\frac{1}{2}y^2 + y \sin(\omega t) + \frac{1}{2}z^2 - z \cos(\omega t) = A$ ,  $y = A \sin t + B \cos t - \frac{\sin(\omega t)}{1-\omega}$ ,

$z = -A \cos t + B \sin t + \frac{\cos(\omega t)}{1-\omega}$ ;

(j)  $y^2 + (z-1)^2 = A$ ,  $x = x_0$ ,  $y = y_0 \cos t - (z_0-1) \sin t$ ,

$z = y_0 \sin t + 1 + (z_0-1) \cos t$ .

13. (a), (h), (j) are steady.

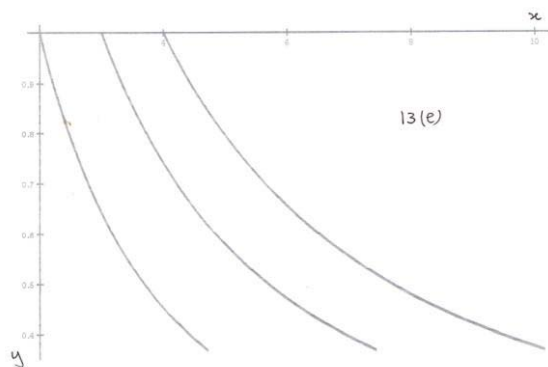
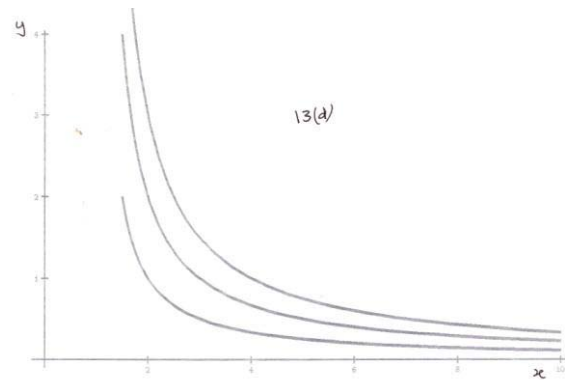
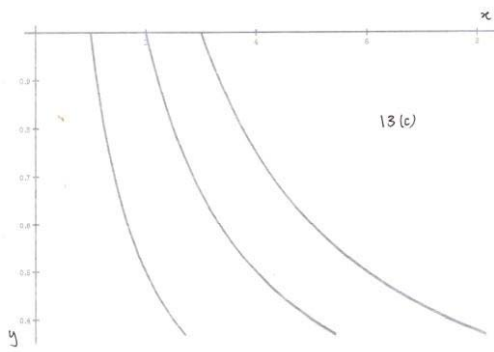

14.  $\mathbf{u} = (\alpha x, \beta y, \gamma z)$  (so steady),  $y^\alpha = Ax^\beta$ ,  $z^\alpha = Bx^\gamma$ .

15.  $y^2 = t^{2\alpha} x^3 + A$ ,  $x = \left(1 + \frac{6}{1+\alpha} t^{1+\alpha}\right)^{1/3}$ ,  $y = \sqrt{1 + \frac{6}{1+3\alpha} t^{1+3\alpha}}$ .

16.  $y^2 + 2e^{\alpha t}/x = A$ ,  $x = \frac{\alpha}{1+\alpha - e^{\alpha t}}$ ,  $y = \sqrt{1 + (e^{2\alpha t} - 1)/\alpha}$ ; steady for  $\alpha = 0$ .

17.  $y^{-1} = t^\alpha \ln|x - \alpha t| + A$ ,  $x = \alpha(t-1) + \alpha e^{-t}$ ,  $y = \frac{1+\alpha}{1+\alpha - t^{1+\alpha}}$ .

19. (a)  $x = Ae^{t^2}$ ,  $y = Be^{-t^2/2}$ ,  $z = Ce^{-t^2/2}$  then  $f = A^2 + B^2 + 2C^2$ .

20.  $u = 2x/t$ ,  $v = -y/t$ ,  $w = -z/t$ .

21. (b)  $\ddot{\mathbf{x}} = \left(4x_0(1+4t^2)e^{2t^2}, 2y_0(-1+2t^2)e^{-t^2}, 2z_0(-1+2t^2)e^{-t^2}\right)$ .

22.  $\mathbf{u} = \left(\frac{2x}{1+t}, -\frac{2y}{1+t}\right)$ ,  $\ddot{\mathbf{x}} = \left(2a, \frac{6b}{(1+t)^4}\right)$ .

23. (a) (d), (e), (f) NO - the rest YES; (b) all YES; (c)  $\alpha + \beta + \gamma = 0$ .

24. (a)  $f = A/r^3$ ; (b)  $a = b = c = 3$ ; (c)  $a = 1, b = c = 0$ .

26.  $f = -4xyzt$ . 27.  $\alpha = 2$ .

28. E.g.  $\mathbf{u} = (A \sin kz + B \cos kz, D \sin kx + C \cos kx + A \cos kz - B \sin kz, -C \sin kx + D \cos kx)$ .

30.  $w = (u - nv)/m$ .

31. (a)  $\rho = \rho_0 \left(1 - g \rho_0 \frac{\gamma - 1}{\gamma p_0} z\right)^{1/(\gamma - 1)}$ ,  $p = p_0 \left(1 - g \rho_0 \frac{\gamma - 1}{\gamma p_0} z\right)^{\gamma/(\gamma - 1)}$ ,

$$T = \frac{p_0}{R \rho_0} \left(1 - g \rho_0 \frac{\gamma - 1}{\gamma p_0} z\right), \quad \frac{dT}{dz} = -\frac{(\gamma - 1)g}{R\gamma};$$

(b)  $\rho = \rho_0 e^{-gz/k}$ ,  $p = p_0 e^{-gz/k}$ ,  $T = p_0/R\rho_0$ ;

(c)  $p = p_0 + \frac{1}{2} \rho_0 g (\alpha z^2 - 2z)$ ; (d)  $p = p_0 + \rho_0 g \left(-z + \frac{2\alpha}{3} (-z)^{3/2}\right)$ ;

(e)  $T = \begin{cases} T_0 - \alpha gz/R, & 0 \leq z \leq H \\ T_0 - \alpha gH/R, & z > H \end{cases}$ ;  $p = \begin{cases} p_0 (1 - \alpha gz/RT_0)^{1/\alpha} & 0 \leq z \leq H \\ p_0 (1 - \alpha gH/RT_0)^{1/\alpha} \exp\left[-\frac{z - H}{RT_0/g - \alpha H}\right] & z > H \end{cases}$

$T \rightarrow \text{const.}, p \rightarrow 0$  as  $z \rightarrow \infty$ ;

(f)  $\rho = \rho_0 \left[1 - \left(\frac{\gamma - 1}{\gamma}\right) \frac{g_0 \rho_0}{p_0} \left(\frac{z}{1 + \alpha z}\right)\right]^{1/(\gamma - 1)}$  (relevant to Newton's law of gravity).

32.  $k = p_0/\rho_0$ ,  $p = p_0 \exp\left[-\frac{g\rho_0}{p_0} z\right]$ .

34.  $w = \alpha x$ ,  $p = p_0 - \rho(g + \alpha u_0)z$  ( $\alpha$  is a free parameter).

36. Both are incompressible and  $\boldsymbol{\omega} = (0, 5, 0)$ ; (b)  $\boldsymbol{\omega} = (0, -2u_0z, 2u_0y)$ .

37. (a)  $\boldsymbol{\omega} = \begin{cases} (0, 0, 2\omega), & 0 \leq r < a \\ \mathbf{0}, & r > a \end{cases}$ ; (b)  $p = \begin{cases} p_0 - \rho\omega^2 a^2 + \frac{1}{2} \rho\omega^2 r^2, & 0 \leq r \leq a \\ p_0 - \frac{1}{2} \rho\omega^2 a^4/r^2, & r > a \end{cases}$

38. (a)  $\boldsymbol{\omega} = \begin{cases} (0, 0, 3\omega r/a), & 0 \leq r < a \\ \mathbf{0}, & r > a \end{cases}$ ; (b)  $p = \begin{cases} p_0 - \frac{3}{4} \rho\omega^2 a^2 + \frac{1}{4} \rho\omega^2 r^4/a^2, & 0 \leq r \leq a \\ p_0 - \frac{1}{2} \rho\omega^2 a^4/r^2, & r > a \end{cases}$

with  $p_0 > \frac{3}{4} \rho\omega^2 a^2$ .

40.  $\phi = \frac{yz}{x^2 + y^2}$ . 41.  $p_1 = p_0 + \frac{1}{2}\rho(u^2 - v^2)$ ,  $p_2 = p_0 + \frac{1}{2}\rho\left[u^2 - \frac{(u - nv)^2}{m^2}\right]$ .

42.  $p_1 = p_0 - 40\rho u_0^2$ ,  $p_2 = p_0 - 4\rho u_0^2$ ;  $p_0 > 40\rho u_0^2$ .

44.  $v = \frac{A_0}{A_1}u_0$ ,  $p = p_0 + \rho gh + \frac{1}{2}\rho\left(1 - \frac{A_0^2}{A_1^2}\right)u_0^2$ .

47. (c)  $\frac{\rho}{\rho_0} = \left[1 + \frac{1}{2}(\gamma - 1)M^2\right]^{-1/(\gamma - 1)}$ ; (d)  $\frac{p}{p_0} = \left[1 + \frac{1}{2}(\gamma - 1)M^2\right]^{-\gamma/(\gamma - 1)}$ ; (e)  $\frac{T}{T_0} = \left[1 + \frac{1}{2}(\gamma - 1)M^2\right]^{-1}$ .

48. (b)  $T = T_0\left[1 + \frac{1}{2}(\gamma - 1)M^2\right]^{-1}$  so  $T$  decreases as  $M$  increases: refrigeration.

52.  $h(t) = \frac{1}{2}h_0\left[1 + \sin\left(\frac{\pi}{2} - \sqrt{\frac{2g}{h_0}}t\right)\right]$ .

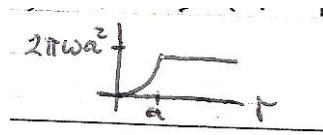

53.  $p = p_0 - \rho\left[an^2R\cos(nt) - \frac{3}{2}a^2n^2\sin^2(nt)\right]$ .

56. (a)  $K = 2\pi\omega r^2$ ; (b)  $K = 2\pi\omega a^2$ .

57. (a)  $K = 2\pi\omega r^3/a$ ; (b)  $K = 2\pi\omega a^2$ .

58.  $\mathbf{u} = (a\lambda \sin s, 0, 0)$  ( $= \mathbf{0}$  at  $s = 0, \pi$ )  $= (\lambda y, 0, 0)$ ;  $K = -a^2\lambda\pi$ .

59. (a)  $u = -2Arz$ ,  $w = -2A(a^2 - z^2 - 2r^2)$ ,  $\dot{\mathbf{u}} = (0, -10Ar, 0)$ ;

(b)  $u = -\frac{3Brz}{(r^2 + z^2)^{5/2}}$ ,  $w = U + B\frac{(r^2 - 2z^2)}{(r^2 + z^2)^{5/2}}$ ,  $\mathbf{u} \rightarrow (0, 0, U)$  as  $r^2 + z^2 \rightarrow \infty$ ;

(c)  $\boldsymbol{\omega} = \mathbf{0}$ ; (d)  $B = \frac{1}{2}Ua^3$ ,  $A = \frac{3B}{2a^5}$  (and then  $U = -\frac{2}{15}a\omega$ ).

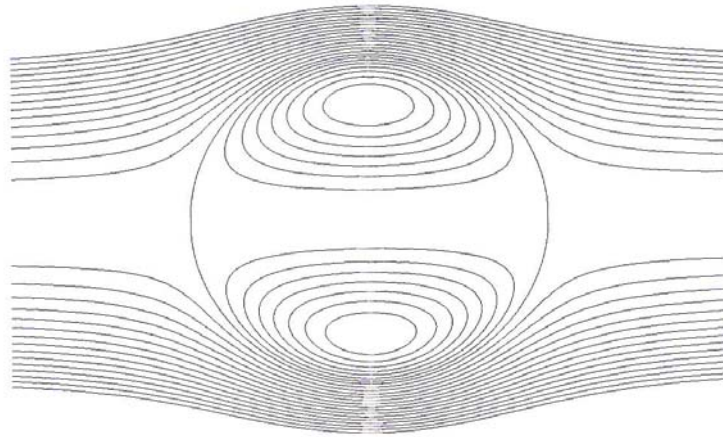

60.  $u(y) = \frac{u_0}{h} y - \frac{\alpha}{2\mu} y(h-y)$ . 61.  $u(y) = -\frac{\alpha}{2\mu} y(h-y)$ ,  $p = p_0 + \alpha x - \rho g y$ .
62.  $u(y) = u_0 \frac{1 - e^{-v_0 y/\nu}}{1 - e^{-v_0 h/\nu}}$ .
63. (a)  $u = e^{-V y/\nu}$ ; (b)  $u = \exp\left[\alpha t - \frac{V}{2\nu} \left(1 + \sqrt{1 + 4\alpha\nu/V^2}\right) y\right]$ .

## STUDY FOR YOUR MASTER'S DEGREE IN THE CRADLE OF SWEDISH ENGINEERING

Chalmers University of Technology conducts research and education in engineering and natural sciences, architecture, technology-related mathematical sciences and nautical sciences. Behind all that Chalmers accomplishes, the aim persists for contributing to a sustainable future – both nationally and globally.

Visit us on **Chalmers.se** or **Next Stop Chalmers** on facebook.



64.  $w = \frac{w_0}{\ln \lambda} \ln(r/R)$ . 65.  $w = \frac{g}{4\nu}(r^2 - b^2) - \frac{\ln(r/b)}{\ln(a/b)} \left[ w_0 - \frac{g}{4\nu}(b^2 - a^2) \right]$ .

66.  $v = a\omega \left[ 1 + \frac{2}{\ln 2} \ln(r/a) \right]$ ;

$$p(a) - p\left(\frac{1}{2}a\right) = \rho a^2 \omega^2 \left[ \left( 1 - 2 \frac{\ln a}{\ln 2} \right)^2 \ln 2 + \frac{2}{\ln 2} \left( 1 - 2 \frac{\ln a}{\ln 2} \right) \left( (\ln a)^2 - (\ln(\frac{1}{2}a))^2 \right) + \frac{4}{3(\ln 2)^2} \left( (\ln a)^3 - (\ln(\frac{1}{2}a))^3 \right) \right]$$

(and various levels of simplification are possible).

67. (c)

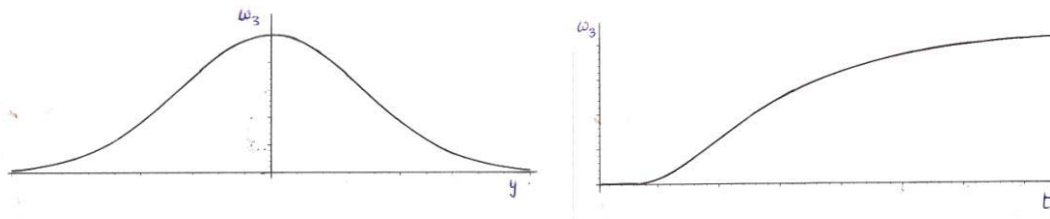

(d)

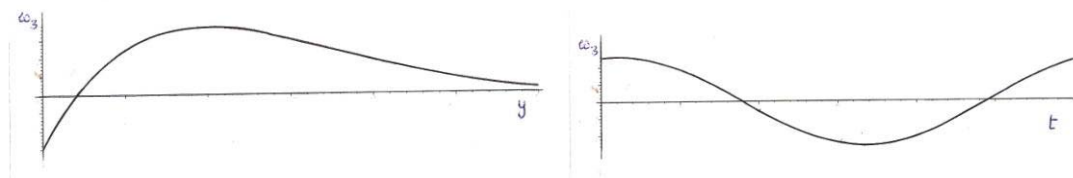

68. (60):  $\omega = \left( 0, 0, -\frac{u_0}{h} + \frac{\alpha}{\mu} \left( \frac{1}{2}h - y \right) \right)$ ; (61):  $\omega = \left( 0, 0, \frac{\alpha}{\mu} \left( \frac{1}{2}h - y \right) \right)$ ;

(62):  $\omega = \left( 0, 0, -\frac{(u_0 v_0 / \nu) e^{-v_0 y / \nu}}{1 - e^{-v_0 h / \nu}} \right)$ ; (63a):  $\omega = \left( 0, 0, \frac{V}{\nu} e^{-V y / \nu} \right)$ ;

(63b):  $\omega = \left( 0, 0, k e^{\alpha t - k y} \right)$ ; (64):  $\omega = \left( 0, -\frac{w_0}{r \ln \lambda}, 0 \right)$ ,

70.  $h(x) = \sqrt{\frac{\pi x}{U_0(2/\pi - \frac{1}{2})}}$ .

71. (a)  $ff'' + f''' = 0$ ,  $f(0) = f'(0) = 0$ ,  $f' \rightarrow 2/\lambda^2$  as  $\eta \rightarrow \infty$ ; any numerical solution,

using  $f(0) = f'(0) = 0$ , and any  $f''(0) \neq 0$ , will generate some  $f'$  as  $\eta \rightarrow \infty$ ; set this value equal to  $2/\lambda^2$ , determine  $\lambda$  and then rescale the numerical solution to find the solution to the original problem.

(b)  $fg' + (g')^2 + gg'' = 0$ ; (c)  $(2\eta - a + F)F'' + F''' = 0$ ; (d)  $C = -B^2/30$ .

72. (b)  $f(0) = 0$ ,  $f \rightarrow 1$  as  $\eta \rightarrow \infty$ .

73. (b)  $f(0) = \frac{2V_0}{m+1}$ ,  $f'(0) = 0$ ,  $f' \rightarrow 1$  as  $\eta \rightarrow \infty$ ; (c)  $\phi'' - (\eta^2 + C\eta + D)\phi = 0$ .

74. (b)  $\frac{\partial^2 w}{\partial z \partial \bar{z}} = 0$  so  $w = F(z) + G(\bar{z})$ . 75.  $\phi = -\frac{1}{2}U \left( r^2 + \frac{a^4}{r^2} \right) \cos(2\theta)$ .

76. (a)  $u = 2kx$ ,  $v = -2ky$ ; (b)  $\phi = A(x^3 - 3xy^2) + B(y^3 - 3x^2y)$ .

77. (b)

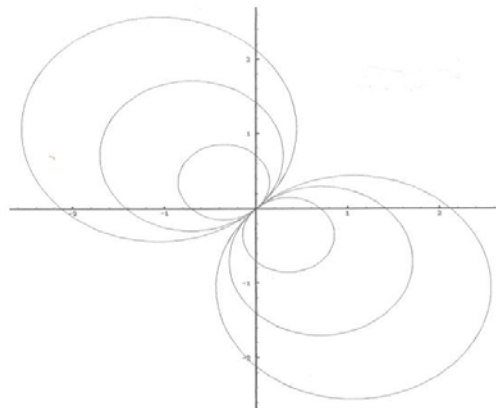

78.

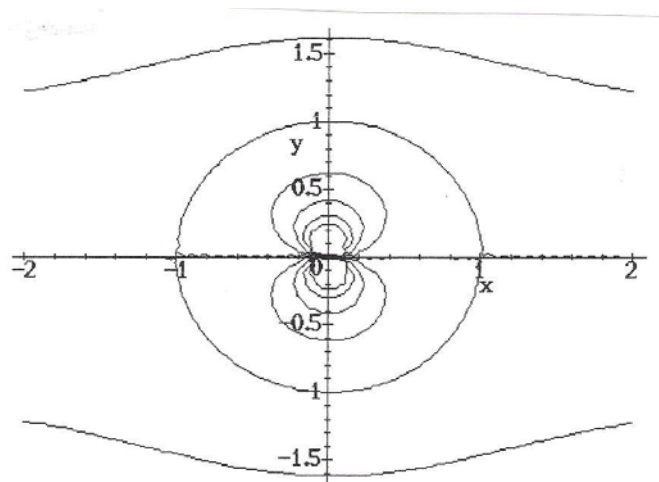

79.  $Ur \sin \theta + \frac{m\theta}{2\pi} = \frac{m}{2}$ ; (c)

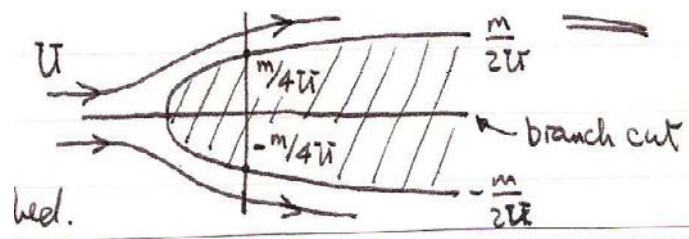

(d)

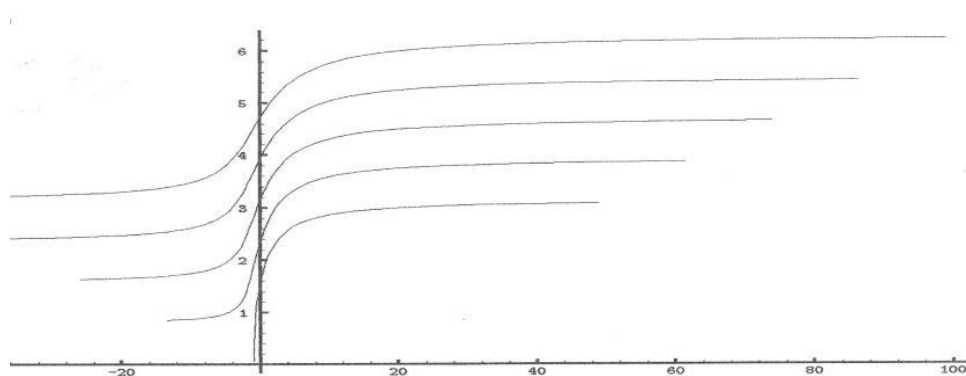

80.  $w = Uz - iaU \log z - Ub^2/z$  (uniform flow + line vortex & dipole both at the origin).

81.  $z = a \cos \theta + ib \sin \theta$  then  $w = U(aa' - bb') \cos \theta$ .

82.

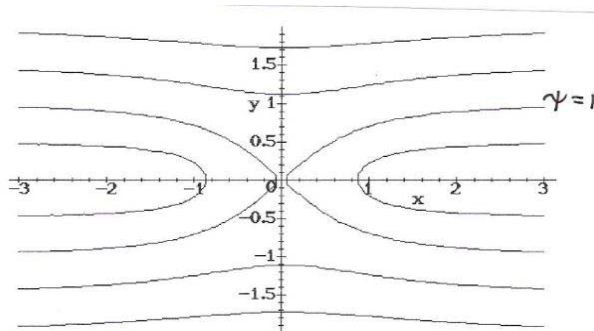

83. 
$$\frac{r}{a} = \frac{K}{4\pi a U} \left[ 1 \pm \sqrt{1 - \left( \frac{4\pi a U}{K} \right)^2} \right].$$

84.

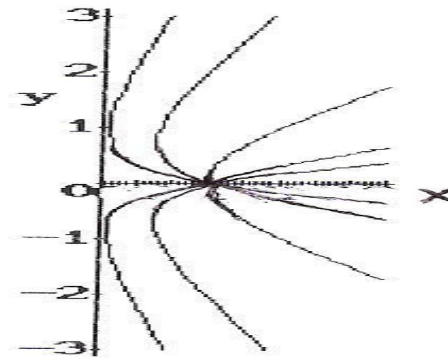

85.  $w = \frac{m}{2\pi} \log \left( \frac{z-a}{z+a} \right); x^2 + y^2 - a^2 = 2\lambda ay$  so  $x^2 + (y - a\lambda)^2 = a^2(1 + \lambda^2)$ .

86. (a)  $w = \frac{m}{2\pi} \log \left( \frac{z^2 - a^2}{z^2} \right);$  (b)  $w \rightarrow -\frac{\gamma}{2\pi} \frac{1}{z^2}$  ( $\gamma = a^2 m$ ).

87.  $w = Uz + \frac{m}{2\pi} \log \left( \frac{z+a}{z-a} \right)$  with stag. pts. at  $z = \pm \sqrt{a^2 + \frac{am}{\pi U}}$ .

88.  $w = \frac{iK}{4\pi} \log \left( \frac{z}{z^2 - a^2} \right)$  with stag. pts. at  $z = \pm ia/\sqrt{3}$ .

89.  $w = \frac{m}{2\pi} \log \left( \frac{z^2 - a^2}{z^2 + a^2} \right)$ .

90. (a)  $w = \frac{m}{2\pi} \log \left( \frac{z^2 + a^2}{z^2 + 4a^2} \right)$ ,  $u = \frac{3m}{10a\pi}$ ,  $v = 0$ ;

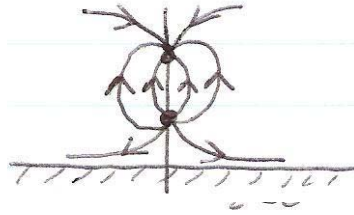

(b)  $w = \frac{m}{2\pi} \log \left( \frac{z^2 - 4a^2}{(z - ia)^2 - a^2} \right)$ ,  $u = 0$ ,  $v = \frac{m}{2a\pi}$ ;

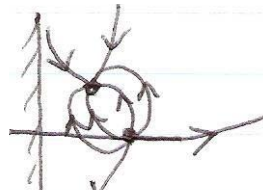

(c)  $w = \frac{m}{2\pi} \log \left( \frac{z^2 - a^2}{(z - ia)^2 - 4a^2} \right)$ ,  $u = 0$ ,  $v = \frac{m}{5a\pi}$ ;

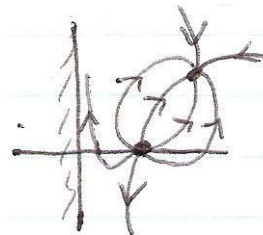

(d)  $w = \frac{m}{2\pi} \log \left( \frac{z^2 + a^2}{(z - a)^2 + a^2} \right)$ ,  $u = \frac{m}{2a\pi}$ ,  $v = 0$ .

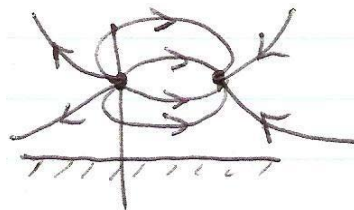

91.  $w = \frac{m}{2\pi} \log(z^2 - a^2)$ . 92.  $w = \frac{m}{2\pi} \log(z^4 - a^4)$ .

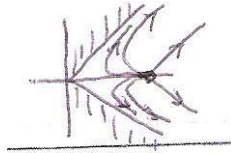

93.  $w = \frac{m}{2\pi} \log((z^3 - a^3 e^{3i\alpha})(z^3 - a^3 e^{-3i\alpha}))$ .

94.  $w = \frac{m}{2\pi} \log\left(\frac{(z - z_0)(z + \bar{z}_0)}{(z - \bar{z}_0)(z + z_0)}\right)$  ( $z_0 = a + ib$ ),

$$x(x^2 - y^2 - a^2 - b^2) + 2xy^2 = \lambda \left[ (x^2 - y^2 - a^2 - b^2)^2 - 4b^2 y^2 + 4x^2 (y^2 - b^2) \right].$$

**Stafford**  
associates

**Find your next education here!**

**Click here**

[bookboon.com/blog/subsites/stafford](http://bookboon.com/blog/subsites/stafford)



95.  $w = \frac{m}{2\pi} \log \left( \frac{z + 2a - ib}{z - 2a - ib} \right)$ ; at  $z = 0$ :  $u = \frac{2am}{\pi} \frac{1}{4a^2 + b^2}$ ,  $v = 0$ ;

new flow  $u = \frac{4am}{\pi} \frac{1}{4a^2 + b^2}$ ,  $v = 0$ .

96.  $w = -\frac{iK}{2\pi} \log \left( \frac{z - ib}{z + ib} \right)$ .

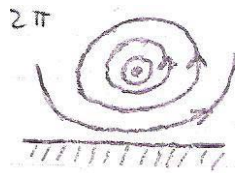

97.  $w = -\frac{iK}{2\pi} \log \left( \frac{z^2 - a^2 e^{2i\alpha}}{z^2 - a^2 e^{-2i\alpha}} \right)$ .

98.  $w = \frac{iK}{2\pi} \log \left( \frac{z + a}{z - a} \right)$ ;  $(x^2 + y^2 - a^2)^2 + 4a^2 y^2 = \lambda [(x - a)^2 + y^2]^2$ .

99. The complex velocity in addition to the singularity at  $z = z_0$  is

$$\frac{dw}{dz} = \frac{iK}{2\pi} \left[ \frac{1}{z_0 - \bar{z}_0} + \frac{1}{z_0 + \bar{z}_0} - \frac{1}{2z_0} \right];$$

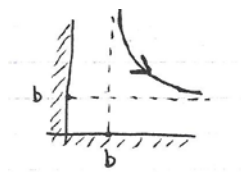

$$\frac{dY}{dX} = \frac{\dot{Y}}{\dot{X}} = \frac{-Y^2 / [X(X^2 + Y^2)]}{X^2 / [Y(X^2 + Y^2)]} = -\frac{Y^3}{X^3}.$$

100. (a)  $Ue^{i\alpha} \frac{a^2}{z}$ ; (b)  $-\log z$ ; (c)  $\log \left( \frac{a^2}{z} + ib \right)$ ; (d)  $-i \log \left( \frac{a^2}{z} + ib \right)$ ;  
 (e)  $\frac{e^{-i\alpha}}{a^2/z - a + ib}$ .

101. (b) Unit circle, mapped in the reverse direction;

(c)  $|\zeta| = \frac{a}{b} \left| \zeta - a^{-1} e^{-i\alpha} \right|$  (a circle for  $a \neq b$ );

(d)  $|\zeta| = \left| \zeta - a^{-1} e^{-i\alpha} \right|$  (a straight line).

102.  $M = -\frac{1}{2} \rho \Re \left[ 2\pi i \left( 2Ua_2 + a_1^2 \right) \right]$  and then  $M = 0$ .

103.  $w = \frac{m}{2\pi} \log \left( \frac{(z-2a)(z-\frac{1}{2}a)}{z} \right)$ ; (b) force is equal and opposite to that on the circular cylinder.

104.  $X = \frac{\rho m^2}{2a\pi} \frac{1}{n(n^2-1)} (> 0), Y = 0$ .

105.  $w = \frac{m}{2\pi} \log \left[ (z-i2a)(z-2a) \left( \frac{a^2}{z} + i2a \right) \left( \frac{a^2}{z} - 2a \right) \right]$ ;  
10  $\rho m^2$       13  $\rho m^2$

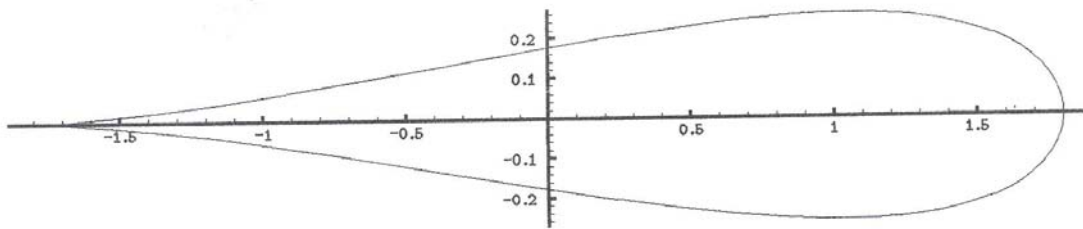

110.  $W = Ue^{-i\alpha} \zeta + Ue^{i\alpha} \frac{c^2}{\zeta}$ .

111.  $\frac{dw}{dz} \rightarrow U \cos \alpha$  as  $\theta \rightarrow 0$ .

112.  $4\pi r \rho U^2 \sin \alpha$  per unit length;  $h = r + \frac{a^2}{r} - a \rightarrow a$  as  $c \rightarrow 0$ .

113.  $6\pi a \rho U^2 \sin \alpha$  per unit length.

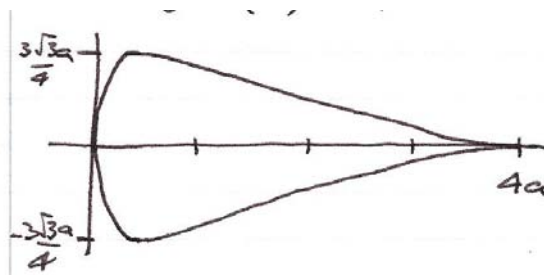

115. (a)  $K \approx 4\pi aU \sin \alpha$ ; (b)  $\rho UK \approx 4\pi a\rho U^2 \sin \alpha$ ;

(c) stag. pt. at  $x \approx -2a \cos 2\alpha$ ,  $y \approx -2\epsilon a \sin 2\alpha$ ; (d)  $u = 0$ ,  $v \approx \frac{2U \sin \alpha}{\epsilon}$ .



**STUDY.**  
The stuff you'll need to make a good living



**PLAY.**  
The stuff that makes life worth living

**NORWAY.**  
**YOUR IDEAL STUDY DESTINATION.**

**WWW.STUDYINNORWAY.NO**  
**FACEBOOK.COM/STUDYINNORWAY**





# Index

Acceleration		16,33,34
adiabatic		47
adverse pressure gradient		151
aerofoil	cambered plate	163
	flat plate	148
	flat plate with circulation	153
	general Joukowski	147.191
	section	112
	simple	64
	supersonic	163
	symmetric	147.163.164
	thin elliptical	164
aerofoil theory		140
ailerons		161
analytic function		90
angle of incidence		148.161
angle preserving transformation		129
anti-symmetry of flow field		150
Archimedes' principle		37
asymptotic suction profile		85
atmosphere	model for	37
	stratosphere	37
	troposphere	37
atmospheric pressure		24,28
avenue of vortices		102
axi-symmetry		57
axi-symmetric Couette flow		84
axi-symmetric flow		21
Ball	cricket, golf, tennis	126
bar magnet		105
Beltrami flow		35
Bernoulli, D.		165
Bernoulli's equation		44.117.123.184
	for pipe flow	46
Bernoulli's theorem		44
Blasius equation		85
Blasius, P.R.H.		82.123.165

Blasius' theorem		121.123.185
blood flow		76
bluff body		102.105
body force		23
boundary condition (no-slip)		76
boundary conditions		26
boundary layer		76,80
	flat plate	81
	generated by a sink	86
	growth	85
	separation	161
	with variable suction	87
boundary-layer equations		77
branch point		141
branching pipe		35,62
building blocks		91.102
Cambered-plate aerofoil		145.163
Cauchy-Riemann relations		59,90,134
Cauchy's integral theorems		123
cavity	collapse of	65
centre of gravity		161
characteristic variables		134
chord (of a wing)		152
circle	transformation of	141
circle theorem (Milne-Thomson)		113.148
circular cylinders	co-axial	84
	rotating	84
circulation		52,55,65,96,119
		150.155
	along a vortex tube	55
	around flat plate	153
	around Joukowski aerofoil	159
	line vortex	53
circulation theorem		56,65,189
civil aircraft (large)		76
Coanda effect		151
Coanda, H.-M.		151.165
co-axial circular cylinders		84
coefficient	lift	157
	Newtonian viscosity	68
	pressure	117

collapse of spherical cavity		65
complex force		122
complex potential		90,91,92
	dipole	102
	dipole in a stream	107
	flow past a circle	113,116,135
	flow past spinning circle	119
	sink	92
	source	92
	source in a stream	105
	uniform flow/stream	92
	velocity field	135
	vortex	96
complex velocity		91,150
	under transformation	133
compressible		8
conformal transformation		128,129,138
conformality fails		130,144
conservative force		42,44
continuously distributed		9
continuous integrand		19,24
continuum hypothesis		9
convective derivative		14
coordinates	cylindrical	20,28,61,184
	cylindrical, axi-symmetric	57
	plane polar	57
	rectangular Cartesian	9,20,184
Couette flow		69
	axial	84
Couette, M.M.A.		69,166
cricket ball		126
critical point		141
cross flow		84
cup	stirring	8
curl		38
curve	parameterised	10
	tangent to	10
cusp (at trailing edge)		162
cylindrical coordinates		20,28,57
	with axi-symmetry	61

D'Alembert's solution (wave eqn)	134
density	9
derivative	14
convective	14
directional	44
material	14
differentiable function	90
differential identities	30
differentiation under the integral sign	18,21,31
dimensionless variables	75
dipole	102.103.113.135
in a stream	107
dipole magnet	105
directional derivative	44
divergence theorem	19,24,30,55,59
dynamical similarity	76

## Free online Magazines





Click here to download 

SpeakMagazines.com



Eddies		119,151
energy	kinetic	44
	potential	44
	thermal	9
energy integral		44
equation	Bernoulli's	44,117,123,184
	Blasius	85
	boundary layer	77
	Euler's	25,26,37,184,186
	Helmholtz's	42,43
	hydrostatic equilibrium	23,24
	Laplace's	58,88,134,184
	mass conservation	18,20,184
	Navier-Stokes (NS)	67,68,184
	of motion	25,26
	of state	9
	Prandtl boundary layer	80
	pressure	48,49,185
	unsteady Bernoulli	49
	vorticity	42
equation of motion		25,26
equation of state		9
equilibrium		23
equipotential lines		65
Euler, L.		26,166
Eulerian description		9,15
Euler's equation of motion		25,26,27,37,184,186
expanding gas		63
expansion fan		163
external force		23
Failure of conformality		130
Ferris wheel		41
flaps		161
flat-plate aerofoil		148
flat-plate aerofoil with circulation		153
flat-plate boundary layer		81
Flettner, A.		126,166

flow	2D	91
	2D incomp irrot	88
	along a river	62
	axi-symmetric	21
	axi-symmetric Couette	84
	Beltrami	35
	blood	76
	building blocks	91
	cross	84
	incompressible	34,35
	inviscid, pipe	22
	irrotational	38
	laminar	76
	model	92
	near trailing edge	164
	non-swirling	21
	past a circle	113.116.135
	past a spinning circle	119
	past an ellipse	135.163
	pipe	21,35
	plug hole	52
	purely radial	93
	separation	119
	sink	92
	source	92
	source + sink	136
	source in a stream	105
	source near a wall	136
	spinning circle	136
	steady	13
	three vortices	136
	through inclined pipe	62
	transformation of	131
	turbulent	76
	two sources + sink	136
	two sources + two sinks	136
	uniform + source	135
	uniform across a section	22
	uniform past a boundary	135.139
	uniform past circle	108
	viscous, pipe	22

flow at infinity	under transformation	132
flow leaves trailing edge smoothly		151
flow of a gas		48
flow past a circle		113,116
flow through pipe		73
flow with a wall		109
fluid	compressible	8
	ideal	25
	incompressible	8,20
	local spin	38
	rotation	38
	spinning	28
football		126
force		23,139
	body	23
	conservative	42,44
	external	23
	internal	23
	viscous	23

I joined MITAS because  
I wanted **real responsibility**

The Graduate Programme  
for Engineers and Geoscientists  
**Maersk.com/Mitas**





**Month 16**  
I was a construction  
supervisor in  
the North Sea  
advising and  
helping foremen  
solve problems

Real work  
International opportunities  
Three work placements







force on spinning circle		126
forces on objects		121.124
friction		23
Froude number		63,75
Froude, W.		167
Galilean invariance		28,37
gas		8
	adiabatic	47
	expanding	63
	flowing	48
	perfect	37,47
	van der Waals	29
Gauss, K.F.		168
Gauss' theorem		19,24,30,55,59
general Joukowski aerofoil		147
	in a flow	159
golf ball		126
gravity		23
	field	44
group property		85
Hagen, G.H.L.		73.168
heat conduction		67
heat diffusion		67
Helmholtz, H.L.F. von		43.169
Helmholtz's equation		42,43
Hill's spherical vortex		65
horseshoe vortex		162
hydraulic jump		62
hydrostatic equilibrium		23,24,36,37
Ideal fluid		8,25
image of a uniform flow in a circle		109
images	method of	109.137
impulsively started plate		71
inclined pipe	flow through	62
incompressible		8,9,61
	flow	34,35,44,63
	fluid	20
integral	energy	44
integral identities		30

internal friction		23,67
invariance	Galilean	28,37
inviscid pipe flow		22
irrotational flow		38,41,49
isotropic		9,23
Joukowski aerofoil		147.191
	MAPLE program	193
Joukowski, N.E.		140.169
Joukowski transformation		140
	extended	164
Joule-Thomson effect		63
jump	condition	20
	hydraulic	62
Karman, T. von		179
Kelvin, Lord		170
Kelvin's circulation theorem		56,65,189
kinematic viscosity		68
kinematics		12
kinetic energy		44,59
Kutta condition		154.160
Kutta, M.W.		154.170
Kutta-Joukowski theorem		126.150.153
		155.160
Lagrange, J.-L.		171
Lagrangian description		9,15
laminar flow		76
Laplace, P.-S.		172
Laplace's equation		58,88,134,184
leading edge		144.147
lift		153
	flat plate	155
	Joukowski aerofoil	160
	zero	150
lift coefficient		157
lifting-line theory		162
Lilienthal, O.		172
line of action (of a force)		158
line	sink	92,94
	source	92,94
	vortex	53,96

line vortices	two	97
liquid		8
local	force	23
	rotation	38
	spin of a fluid	38
Mach, E.		63
Mach number		48,63
macroscopic scale		9
Magnus, H.G.		126.173
MAPLE program	for Joukowski aerofoils	193
mass conservation		35
	equation	18,20,184
material derivative		14,33,34
method of images		109.137
microscopic scale		9
Milne-Thomson circle theorem		113.148
Milne-Thomson, L.M.		173
Mittag-Leffler identity		99
Mittag-Leffler, M.G.		174

## Need help with your dissertation?

Get in-depth feedback & advice from experts in your topic area. Find out what you can do to improve the quality of your dissertation!

**Get Help Now**



Go to [www.helpmyassignment.co.uk](http://www.helpmyassignment.co.uk) for more info



mixture (gas/liquid)		46
model atmosphere		37
model	flow	92
	fluid	8
molecular scale		9
moment		139
	of a force	123
	of the lift force	150.158
Navier, C.L.M.H.		68.174
Navier-Stokes (NS) equation		67,68,75,184
Newtonian viscosity		68
Newton's second law		23,25
Nikuradse, J.		83
non-dimensional variables		75
nonlinear		15
non-swirling flow		21
no-slip condition		68,76
number	Froude	63
	Mach	48,63
	Reynolds	75
Ocean-going liner		76
oriented surface		52
oscillating	flat plate	72
	pressure	64
Parameterised curve		10
particle (point)		9
particle paths (PPs)		10,11,12,32,33
perfect gas		37,47
physically realistic pressure		46
pipe	branching	35,62
pipe flow		21,35,73
	inviscid	22
	using Bernoulli	46
	viscous	22
pitching-up moment		158.161
Pitot, H.		174
pitot tube		45
pitot-static tube		45
plane Poiseuille flow		68

plane polar coordinates		57
plate	cambered	145
	impulsively started	71
	oscillating	72
plug-hole flow		52
point	stagnation	11
	vortex	96
point (particle)		9
Poiseuille, J.L.M.		68,73,175
Poisson, S.D.		68.175
polar coordinates	velocity components	117
poles (of a function)		123.125
position vector		9
potential	complex	90
	energy	44
	function	134
Prandtl boundary-layer equations		80
Prandtl, L.		77.123.176
pressure		9,23
	atmospheric	24,28
	in water	24
	oscillating	64
	physically realistic	46
pressure	coefficient	117
	distribution around circle	117
	equation	48,49,185
pressure force	resultant	121
pressure gradient		68,73,84
	adverse	151
purely radial flow		93
Quarter-chord point		158
Raising water		62
Rankine vortex		61.108
rectangular Cartesian coordinates		9,20
rectangular hyperbolae		11
residue		123.125
resultant pressure force		121
Reynolds number		75.152
Reynolds, O.		75.176

Riemann sheet		94
ring vortex		66
river	flow along	62
Robins, B.		126.177
rotating cylinders		84
rotation	Ferris wheel	41
	solid body	39
	vorticity	39
rotation in a fluid		38
rotational		44
rotational flow		49
rotational v. irrotational		49
row of vortices		99
Saint-Venant, A.J.C.B. de		68.178
scalar field		9
scale (size)		75
scaled variables		78
second law	Newton's	23,25
separation		119
shock wave		20.163
similarity	dynamical	76
singularity		92,96
	under transformation	132
sink	flow	92
	strength	94
size (scale)		75
slats		161
smoke ring		66
solids		8
sound speed		48
source + sink		95.136
source	flow	92
	in a stream	105
	near a wall	136
	strength	94
source with a boundary		110
	under transformation	133
source with two boundaries		111
speed of sound		48
speed*area		22,46,51,74
spherical cavity collapse		65

spin		39
spinning circular cylinder		136
spinning fluid		28
stagnation point		11.120.136.150.155
stall		151.161
static tube		45
steady flow		13,32,44
stirring a cup		8
Stokes, G.G.		68.179
Stokes'	first problem	71
	second problem	72
	theorem	31,41,54
stratosphere		37
streak lines		14
stream function		56,57,91,134,185
streamlines (SLs)		10,11,32,33,65,91
	under transformation	131
subsonic flow		63
suction		84,85
supersonic	aerofoil	163
	flow	20,63
swimming protozoa		76
symmetric aerofoil		147.163.164
Tangent to a curve		10
temperature		9
tennis ball		126
theorem	Bernoulli's	44
	Blasius'	121.123.185
	Cauchy integral	123
	circle (Milne-Thomson)	113
	divergence	19,24,30,55,59
	Gauss'	19,24,30,55,59
	Kelvin's circulation	56,65,189
	Kutta-Joukowski	126
	Stokes'	31,41,54
	uniqueness	59
thermal conductivity		67
thermal energy		9
thermodynamics		9
thin elliptical aerofoil		164
thin layer		78

thixotropic		8
three vortices		136
tornado		52,54,56
total head		62
trailing edge		144.147.151.155
	behaviour of flow near	164
	cusp	162
	velocity at	164
transformation	conformal	128
	Joukowski	140
	von Karman-Trefftz	167
transformation of circles		141
transformation of flows		131
	complex velocity	133
	flow at infinity	132
	singularities	132
	source with a boundary	133
	streamlines	131
trapped vorticity		43
triple product		44
troposphere		37
turbulent flow		76.151

**Question:**  
 What do Skype and Spotify have in common with color screen graphics and the computer mouse?

– They are all Swedish inventions.



STUDYINSWEDEN.SE

## Be innovative. Study in Sweden



two complex planes	mapping between	128
two line vortices		97
two sources + sink		136
two sources + two sinks		136
two-dimensional flows		91
two-dimensional incomp irrot flow		88
Uniform across a section		22,46
uniform flow		92
	past a boundary	135.139
	past a circle	108.116
	past a spinning circle	119
uniform flow + source		135
uniform stream		92
unique	pressure field	60
	velocity field	60
uniqueness		59
	theorem	59
unsteady Bernoulli equation		49
Van der Waals		29
velocity		34
	at trailing edge	164
	potential	41,62,91,185
	profile	69,73
	vector	9
velocity components	polars	117
velocity field		9,13
	complex potential	135
viscosity		8
	aerofoil theory	151
	kinematic	68
	Newtonian	68
viscous	flow	8,67
	fluid	67
	forces	23
	pipe flow	22
von Karman, T.		179
von Karman street vortex		100.102
von Karman-Trefftz transform		162

vortex	Hill's spherical	65
	horseshoe	162
	line	96
	point	96
	Rankine	61.108
	ring	66
	street	100.102
	von Karman street	100.102
vortex	lines	52
	shedding	102.151
vortex tube		52
	circulation along	55
vortices	avenue of	102
	row of	99
vorticity		49,52,61,85,185
	equation	42
	through a surface	54
	trapped	43
	zero	38
	vector	38
Wake		119
water pressure		24
work done		44
Wright brothers		140.145.180
Wright Flyer I		145
Wright, O.		180
Wright, W.		180
Zhukovsky see Joukowski		140