

# Measuring Vibration



# Introduction

This booklet answers some of the basic questions asked by the newcomer to vibration measurement. It gives a brief explanation to the following:

	See Page		See Page
Why do we measure vibration?	2 & 3	Environmental Influences — Cable Noise	19
Where does it come from?	3	Other Environmental Influences	20 & 21
What is vibration?	4	Accelerometer calibration	22
How to quantify the vibration level	5	A simple calibrator	23
The vibration parameters, Acceleration, Velocity and Displacement	6	Force and impedance measurements	24
Measurement Units	6	Logarithmic scales and decibels	25
Which parameter to measure	7	Why use an accelerometer preamplifier?	26
The piezoelectric accelerometer	8	The vibration meter	27
Practical accelerometer designs	9	What is frequency analysis?	28
Accelerometer types	10	Constant bandwidth or constant percentage bandwidth frequency analysis	29
Accelerometer characteristics	11	Filter bandwidth considerations	30
Accelerometer frequency range	12	Defining the filter bandwidth	31
Avoiding errors due to accelerometer resonance	13	Measuring instrumentation	32
Choosing a mounting position for the accelerometer	14	Recording results	33
How to mount the accelerometer	15 & 16	Using vibration measurements	34
Environmental Influences — General	17	Vibration as a machine condition indicator	35
Environmental Influences — Temperature	18	Vibration trouble shooting charts	36 & 37
		Vibration and the human body	38

## Background

Since man began to build machines for industrial use, and especially since motors have been used to power them, problems of vibration reduction and isolation have engaged engineers.

Gradually, as vibration isolation and reduction techniques have become an integral part of machine design, the need for accurate measurement and analysis of mechanical vibration has grown. This need was largely satisfied, for the slow and robust machines of yesteryear, by the experienced ear and touch of the plant engineer, or by simple optical instruments measuring vibratory displacement.

Over the last 15 or 20 years a whole new technology of vibration measurement has been developed which is suitable for investigating modern highly stressed, high speed machinery. Using piezoelectric accelerometers to convert vibratory motion into an electrical signal, the process of measurement and analysis is ably performed by the versatile abilities of electronics.

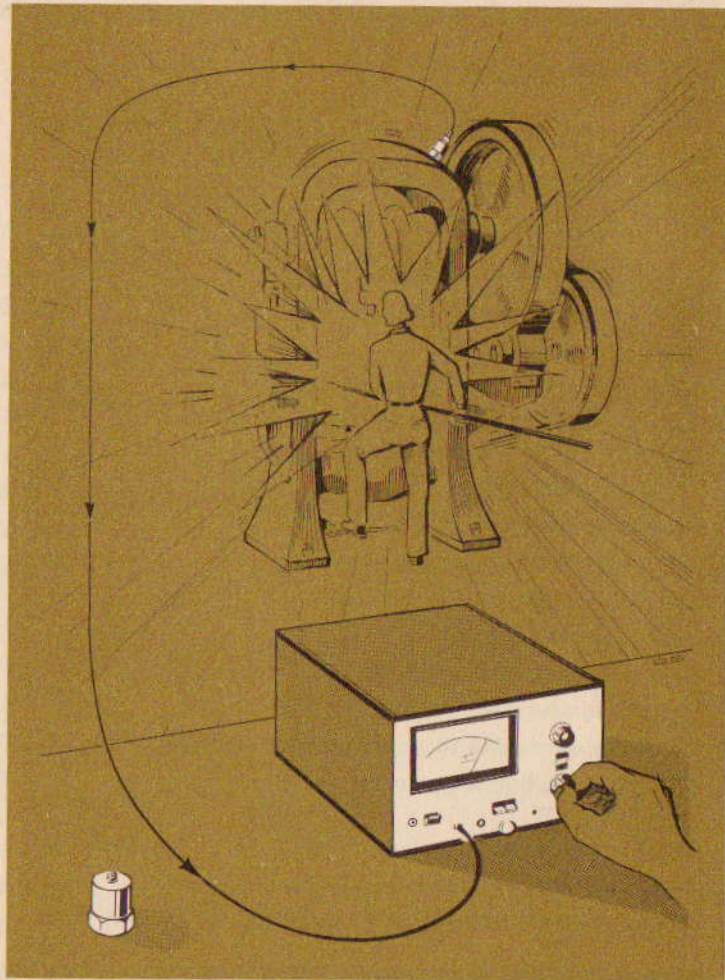

## Where does it come from?

In practice it is very difficult to avoid vibration. It usually occurs because of the dynamic effects of manufacturing tolerances, clearances, rolling and rubbing contact between machine parts and out-of-balance forces in rotating and reciprocating members. Often, small insignificant vibrations can excite the resonant frequencies of some other structural parts and be amplified into major vibration and noise sources.

Sometimes though, mechanical vibration performs a useful job. For example, we generate vibration intentionally in component feeders, concrete compactors, ultrasonic cleaning baths, rock drills and pile drivers. Vibration testing machines are used extensively to impart a controlled level of vibration energy to products and sub-assemblies where it is required to examine their physical or functional response and ascertain their resistability to vibration environments.

A fundamental requirement in all vibration work, whether it is in the design of machines which utilize its energies or in the creation and maintenance of smoothly running mechanical products, is the ability to obtain an accurate description of the vibration by measurement and analysis.

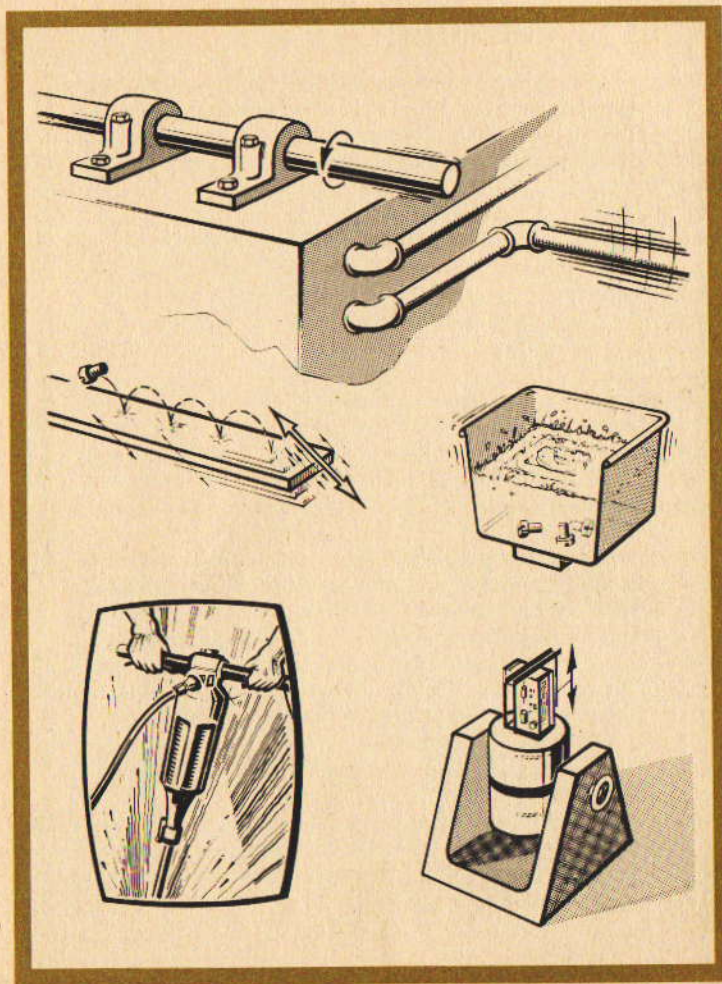

# What is Vibration?

A body is said to vibrate when it describes an oscillating motion about a reference position. The number of times a complete motion cycle takes place during the period of one second is called the **Frequency** and is measured in hertz (Hz).

The motion can consist of a single component occurring at a single frequency, as with a tuning fork, or of several components occurring at different frequencies simultaneously, as for example, with the piston motion of an internal combustion engine.

Vibration signals in practice usually consist of very many frequencies occurring simultaneously so that we cannot immediately see just by looking at the amplitude-time pattern, how many components there are, and at what frequencies they occur.

These components can be revealed by plotting vibration amplitude against frequency. The breaking down of vibration signals into individual frequency components is called frequency analysis, a technique which may be considered the cornerstone of diagnostic vibration measurements. The graph showing the vibration level as a function of frequency is called a frequency spectrogram.

When frequency analyzing machine vibrations we normally find a number of prominent periodic frequency components which are directly related to the fundamental movements of various parts of the machine. With frequency analysis we are therefore able to track down the source of undesirable vibration.

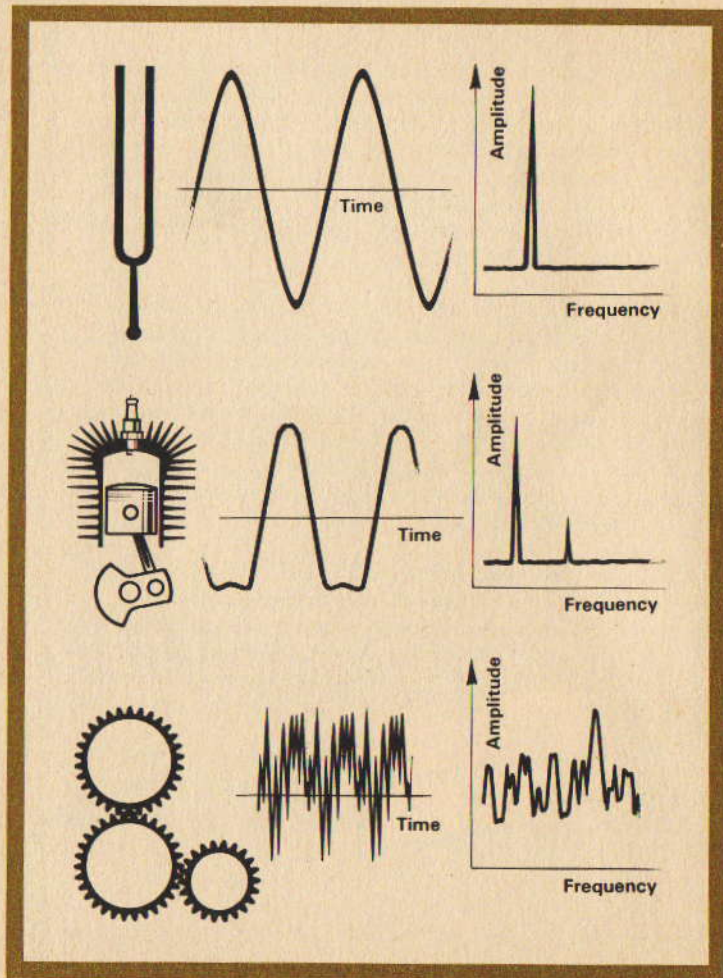

# Quantifying the Vibration Level

The vibration amplitude, which is the characteristic which describes the severity of the vibration, can be quantified in several ways. On the diagram, the relationship between the peak-to-peak level, the peak level, the average level and the RMS level of a sinewave is shown.

The **peak-to-peak** value is valuable in that it indicates the maximum excursion of the wave, a useful quantity where, for example, the vibratory displacement of a machine part is critical for maximum stress or mechanical clearance considerations.

The **peak** value is particularly valuable for indicating the level of short duration shocks etc. But, as can be seen from the drawing, peak values only indicate when maximum level has occurred, no account is taken of the time history of the wave.

The rectified **average** value, on the other hand, does take the time history of the wave into account, but is considered of limited practical interest because it has no direct relationship with any useful physical quantity.

The **RMS** value is the most relevant measure of amplitude because it both takes the time history of the wave into account and gives an amplitude value which is directly related to the energy content, and therefore the destructive abilities of the vibration.

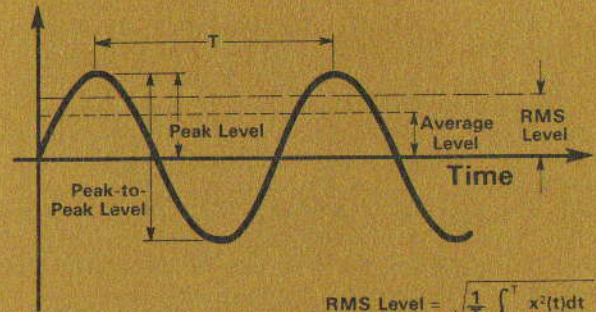

$$\text{RMS Level} = \sqrt{\frac{1}{T} \int_0^T x^2(t) dt}$$

$$\text{Average Level} = \frac{1}{T} \int_0^T |x| dt$$

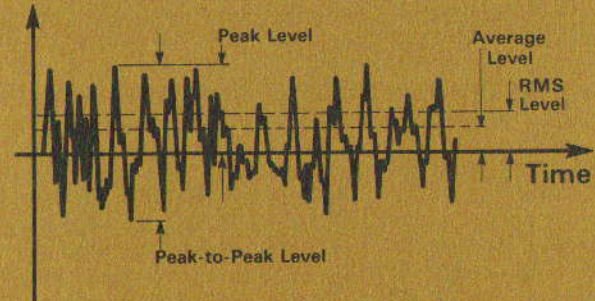

# The Vibration Parameters, Acceleration, Velocity and Displacement. Measuring Units

When we looked at the vibrating tuning fork we considered the amplitude of the wave as the physical displacement of the fork ends to either side of the rest position. In addition to Displacement we can also describe the movement of the fork leg in terms of its velocity and its acceleration. The form and period of the vibration remain the same whether it is the displacement, velocity or acceleration that is being considered. The main difference is that there is a phase difference between the amplitude-time curves of the three parameters as shown in the drawing.

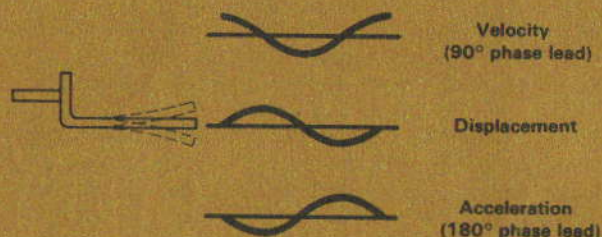

For sinusoidal signals, displacement, velocity and acceleration amplitudes are related mathematically by a function of frequency and time, this is shown graphically in the diagram. If phase is neglected, as is always the case when making time-average measurements, then the velocity level can be obtained by dividing the acceleration signal by a factor proportional to frequency, and the displacement can be obtained by dividing the acceleration signal by a factor proportional to the square of frequency. This division is performed by electronic integrators in the measuring instrumentation.

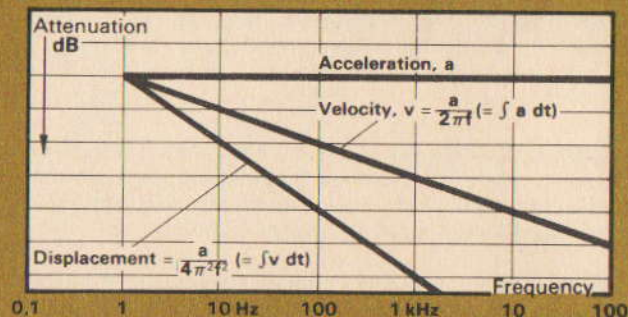

The vibration parameters are almost universally measured in metric units in accordance with ISO requirements, these are shown in the table. The gravitational constant "g" is still widely used for acceleration levels although it is outside the ISO system of coherent units. Fortunately a factor of almost 10 (9,81) relates the two units so that mental conversion within 2% is a simple matter.

Units to ISO 1000

Displacement:	m, mm, $\mu\text{m}$
Velocity:	m/s, mm/s (or $\text{ms}^{-1}$ , $\text{mms}^{-1}$ )
Acceleration:	$\text{m/s}^2$ ( $\text{ms}^{-2}$ ) (Note: 1 g = 9,81 $\text{m/s}^2$ )

## Considerations in choosing Acceleration, Velocity, or Displacement parameters

By detecting vibratory acceleration we are not tied to that parameter alone, with electronic integrators we can convert the acceleration signal to velocity and displacement. Most modern vibration meters are equipped to measure all three parameters.

Where a single, wide frequency band vibration measurement is made, the choice of parameter is important if the signal has components at many frequencies. Measurement of displacement will give the low frequency components most weight and conversely acceleration measurements will weight the level towards the high frequency components.

Experience has shown that the overall RMS value of vibration velocity measured over the range 10 to 1000 Hz gives the best indication of a vibration's severity. A probable explanation is that a given velocity level corresponds to a given energy level so that vibration at low and high frequencies are equally weighted from a vibration energy point of view. In practice many machines have a reasonably flat velocity spectrum.

Where narrow band frequency analysis is performed the choice of parameter will be reflected only in the way the analysis plot is tilted on the chart paper (as demon-

strated in the middle diagram on the opposite page). This leads us to a practical consideration that can influence the choice of parameter. It is advantageous to select the parameter which gives the flattest frequency spectrum in order to best utilise the dynamic range (the difference between the smallest and largest values that can be measured) of the instrumentation. For this reason the velocity or acceleration parameter is normally selected for frequency analysis purposes.

Because acceleration measurements are weighted towards high frequency vibration components, this parameter tends to be used where the frequency range of interest covers high frequencies.

The nature of mechanical systems is such that appreciable displacements only occur at low frequencies, therefore displacement measurements are of limited value in the general study of mechanical vibration. Where small clearances between machine elements are being considered, vibratory displacement is of course an important consideration. Displacement is often used as an indicator of unbalance in rotating machine parts because relatively large displacements usually occur at the shaft rotational frequency, which is also the frequency of greatest interest for balancing purposes.

# The Piezoelectric Accelerometer

The transducer which, nowadays, is more-or-less universally used for vibration measurements is the piezoelectric accelerometer. It exhibits better all-round characteristics than any other type of vibration transducer. It has very wide frequency and dynamic ranges with good linearity throughout the ranges. It is relatively robust and reliable so that its characteristics remain stable over a long period of time.

Additionally, the piezoelectric accelerometer is self-generating, so that it doesn't need a power supply. There are no moving parts to wear out, and finally, its acceleration proportional output can be integrated to give velocity and displacement proportional signals.

The heart of a piezoelectric accelerometer is the slice of piezoelectric material, usually an artificially polarized ferroelectric ceramic, which exhibits the unique piezoelectric effect. When it is mechanically stressed, either in tension, compression or shear, it generates an electrical charge across its pole faces which is proportional to the applied force.

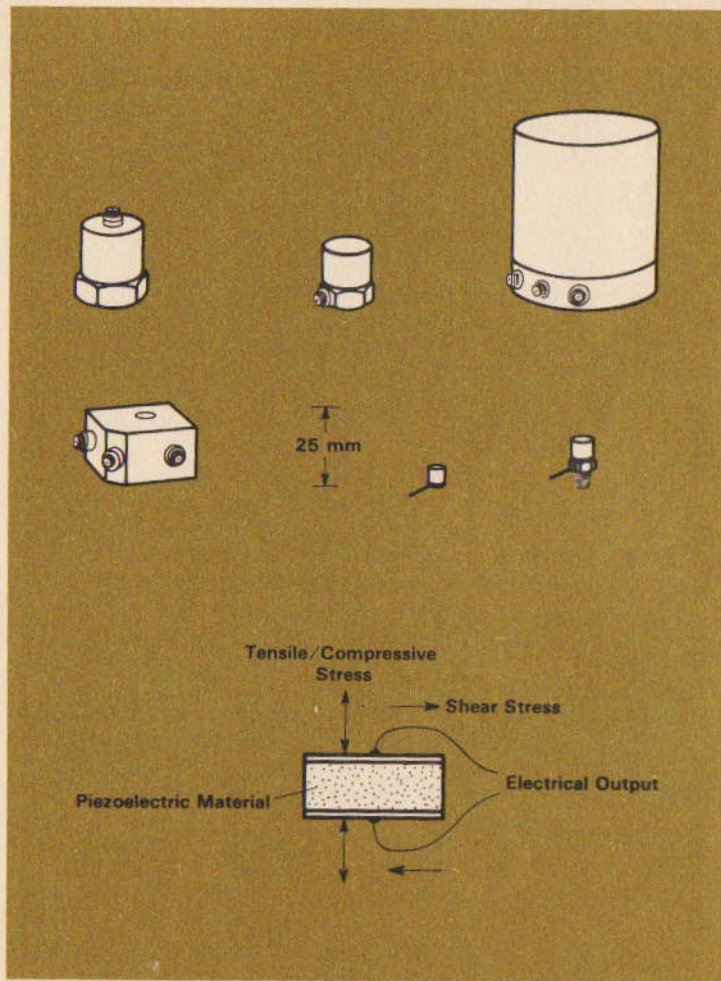

## Practical Accelerometer Designs

In practical accelerometer designs, the piezoelectric element is arranged so that when the assembly is vibrated the mass applies a force to the piezoelectric element which is proportional to the vibratory acceleration. This can be seen from the law, Force = Mass  $\times$  Acceleration.

For frequencies lying well under the resonant frequency of the complete spring-mass system, the acceleration of the mass will be the same as the acceleration of the base, and the output signal magnitude will therefore be proportional to the acceleration to which the pick-up is subjected.

Two configurations are in common use:

**The Compression Type** where the mass exerts a compressive force on the piezoelectric element and

**The Shear Type** where the mass exerts a shear force on the piezoelectric element.

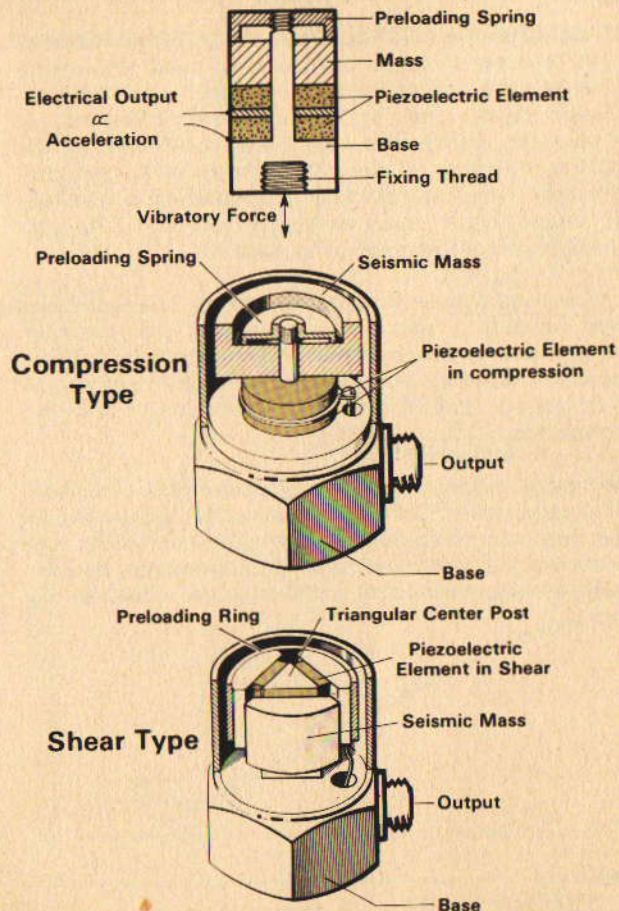

# Accelerometer Types

Most manufactures have a wide range of accelerometers, at first sight maybe too many to make the choice easy. A small group of "general purpose" types will satisfy most needs. They are available with either top or side mounted connectors and have sensitivities in the range 1 to 10 mV or pC per  $m/s^2$ . The Brüel & Kjær Uni-Gain® types have their sensitivity normalized to a convenient "round figure" such as 1 or 10 pC/ $ms^{-2}$  to simplify calibration of the measuring system.

The remaining accelerometers have their characteristics slanted towards a particular application. For example, small size accelerometers that are intended for high level or high frequency measurements and for use on delicate structures, panels, etc. and which weigh only 0,5 to 2 grammes.

Other special purpose types are optimized for: simultaneous measurement in three mutually perpendicular planes; high temperatures; very low vibration levels; high level shocks; calibration of other accelerometers by comparison; and for permanent monitoring on industrial machines.

## General Purpose Types



Sensitivity:	1 to 10 pC/ $ms^{-2}$
Weight:	10 to 50 grammes
Frequency Range:	0 to 12000 Hz

## Miniature Types



Sensitivity:	0,05 to 0,3 pC/ $ms^{-2}$
Weight:	0,4 to 2 grammes
Frequency Range:	1 to 25000 Hz

## Other Types

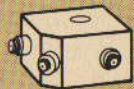

1



2

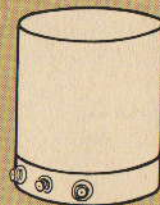

3

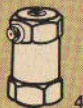

4



5

- 1 For triaxial measurements
- 2 For permanent monitoring on industrial machines
- 2 For use in very high temperatures
- 3 For building and other structural vibration measurements
- 4 For calibration and other reference purposes
- 5 For very high shock measurements  
[1000  $km/s^2$  (100 000 g)]

# Accelerometer Characteristics (Sensitivity, Mass and Dynamic Range)

The sensitivity is the first characteristic normally considered. Ideally we would like a high output level, but here we have to compromise because high sensitivity normally entails a relatively big piezoelectric assembly and consequently a relatively large, heavy unit.

In normal circumstances the sensitivity is not a critical problem as modern preamplifiers are designed to accept these low level signals.

The mass of the accelerometers becomes important when measuring on light test objects. Additional mass can significantly alter the vibration levels and frequencies at the measuring point.

As a general rule, the accelerometer mass should be no more than one tenth of the dynamic mass of the vibrating part onto which it is mounted.

When it is wished to measure abnormally low or high acceleration levels, the dynamic range of the accelerometer should be considered. The lower limit shown on the drawing is not normally determined directly by the accelerometer, but by electrical noise from connecting cables and amplifier circuitry. This limit is normally as low as one hundredth of a  $m/s^2$  with general purpose instruments.

The upper limit is determined by the accelerometer's structural strength. A typical general purpose accelerometer is linear up to 50000 to 100000  $m/s^2$ , that is well into the range of mechanical shocks. An accelerometer especially designed for the measurement of mechanical shocks may be linear up to 1000  $km/s^2$  (100000 g).

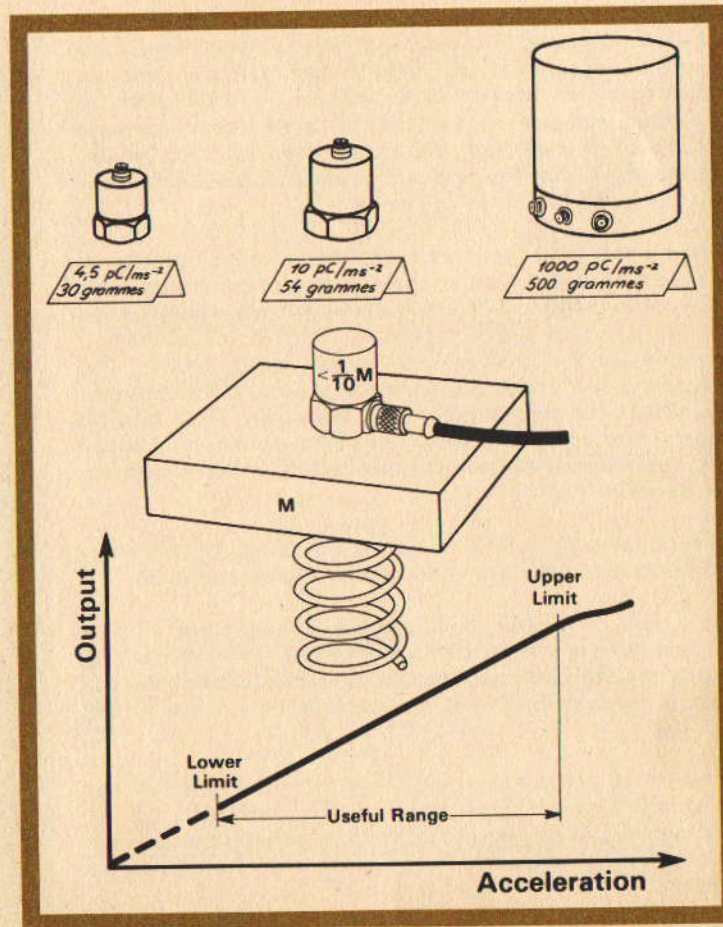

# Accelerometer Frequency Range Considerations

Mechanical systems tend to have much of their vibration energy contained in the relatively narrow frequency range between 10 Hz to 1000 Hz but measurements are often made up to say 10 kHz because there are often interesting vibration components at these higher frequencies. We must ensure, therefore, when selecting an accelerometer, that the frequency range of the accelerometer can cover the range of interest.

The frequency range over which the accelerometer gives a true output is limited at the low frequency end in practice, by two factors. The first is the low frequency cut-off of the amplifier which follows it. This is not normally a problem as the limit is usually well below one Hz. The second is the effect of ambient temperature fluctuations, to which the accelerometer is sensitive. With modern shear type accelerometers this effect is minimal, allowing measurements down to below 1 Hz for normal environments.

The upper limit is determined by the resonant frequency of the mass-spring system of the accelerometer itself.

As a rule of thumb, if we set the upper frequency limit to one-third of the accelerometer's resonance frequency, we know that vibration components measured at the upper frequency limit will be in error by no more than + 12%.

With small accelerometers where the mass is small, the resonant frequency can be as high as 180 kHz, but for the somewhat larger, higher output, general purpose accelerometers, resonant frequencies of 20 to 30 kHz are typical.

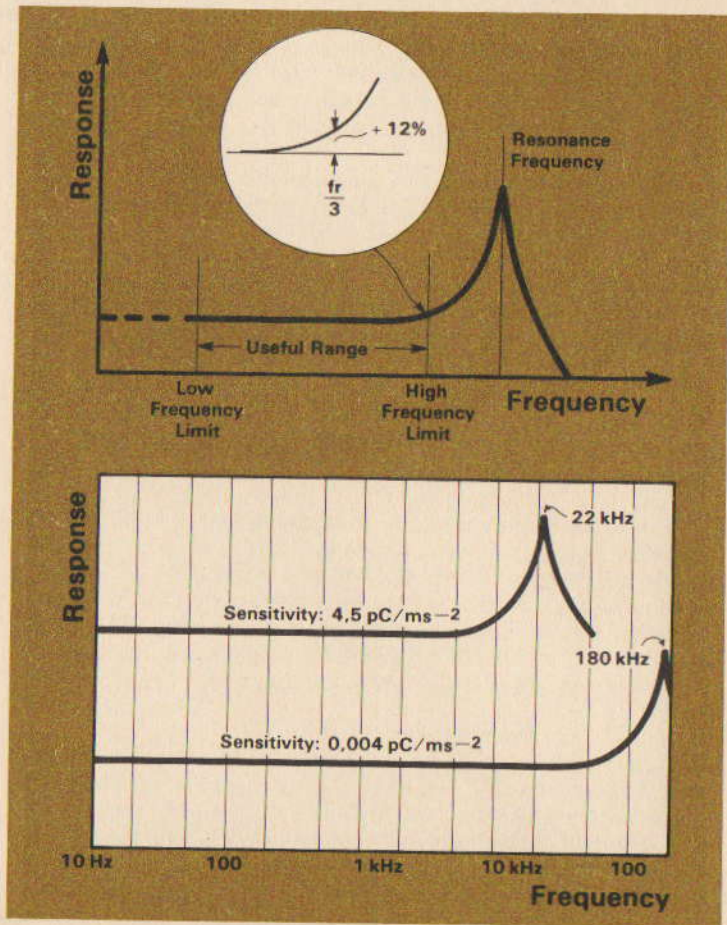

# Avoiding Errors due to Accelerometer Resonance

As the accelerometer will typically have an increase in sensitivity at the high frequency end due to its resonance, its output will not give a true representation of the vibration at the measuring point at these high frequencies.

When frequency analyzing a vibration signal, one may easily recognize that a high frequency peak is due to the accelerometer resonance, and therefore ignore it. But if an overall wideband reading is taken which includes the accelerometer resonance it will give a totally inaccurate result if, at the same time, the vibration to be measured also has components in the region around the resonant frequency.

This problem is overcome by choosing an accelerometer with as wide a frequency range as possible and by using a low-pass filter, which is normally included in vibration meters and preamplifiers, to cut away the undesired signal caused by the accelerometer resonance.

Where measurements are confined to low frequencies, high frequency vibration and accelerometer resonance effects can be removed with mechanical filters. They consist of a resilient medium, typically rubber, bonded between two mounting discs, which is mounted between the accelerometer and the mounting surface. They will typically reduce the upper frequency limit to between 0,5 kHz to 5 kHz.

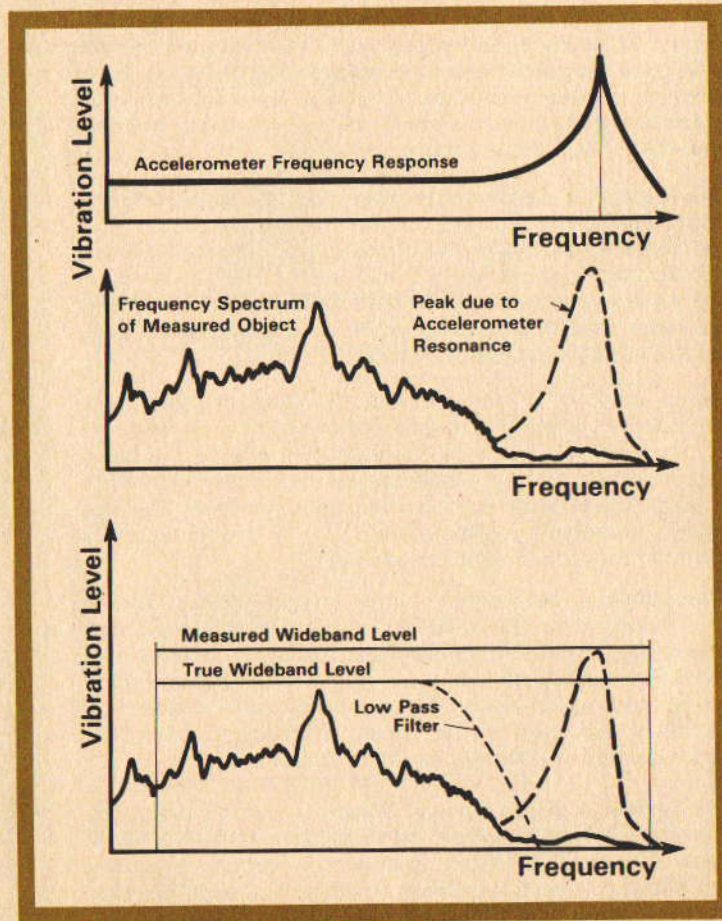

# Choosing a Mounting Position for the Accelerometer

The accelerometer should be mounted so that the desired measuring direction coincides with its main sensitivity axis. Accelerometers are also slightly sensitive to vibrations in the transverse direction, but this can normally be ignored as the transverse sensitivity is typically less than 1% of the main axis sensitivity.

The reason for measuring vibration on the object will usually dictate the position of the measuring point. Take the bearing housing in the drawing as an example. Here, acceleration measurements are being used to monitor the running condition of the shaft and bearing. The accelerometer should be positioned to maintain a direct path for the vibration from the bearing.

Accelerometer "A" thus detects the vibration signal from the bearing predominant over vibrations from other parts of the machine, but accelerometer "B" detects the bearing vibration, probably modified by transmission through a joint, mixed with signals from other parts of the machine. Likewise, accelerometer "C" is positioned in a more direct path than accelerometer "D".

The question also arises — in which direction should one measure on the machine element in question? It is impossible to state a general rule, but as an example, for the bearing shown, one could gain valuable information for monitoring purposes by measuring both in the axial direction and one of the radial directions, usually the one expected to have the lowest stiffness.

The response of mechanical objects to forced vibrations is a complex phenomenon, so that one can expect, especially at high frequencies, to measure significantly different vibration levels and frequency spectra, even on adjacent measuring points on the same machine element.

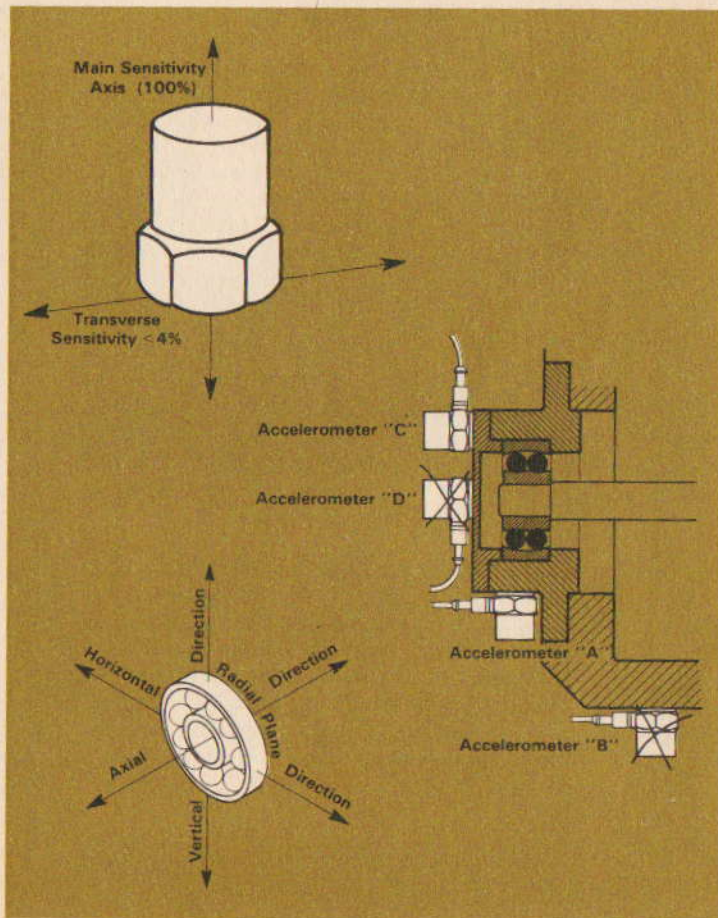

## Mounting the Accelerometer

The method of mounting the accelerometer to the measuring point is one of the most critical factors in obtaining accurate results from practical vibration measurements. Sloppy mounting results in a reduction in the mounted resonant frequency, which can severely limit the useful frequency range of the accelerometer. The ideal mounting is by a threaded stud onto a flat, smooth surface as shown in the drawing. A thin layer of grease applied to the mounting surface before tightening down the accelerometer will usually improve the mounting stiffness. The tapped hole in the machine part should be sufficiently deep so that the stud is not forced into the base of the accelerometer. The upper drawing shows a typical response curve of a general purpose accelerometer mounted with a fixing stud on a flat surface. The resonant frequency attained is almost as high as the 32 kHz mounted resonant frequency attained under calibration where the mounting surface is dead flat and smooth.

A commonly used alternative mounting method is the use of a thin layer of bees-wax for sticking the accelerometer into place. As can be seen from the response curve, the resonant frequency is only slightly reduced (to 29 kHz). Because bees-wax becomes soft at higher temperatures, the method is restricted to about 40°C. With clean surfaces, bees-wax fixing is usable up to acceleration levels of about 100 m/s<sup>2</sup>.

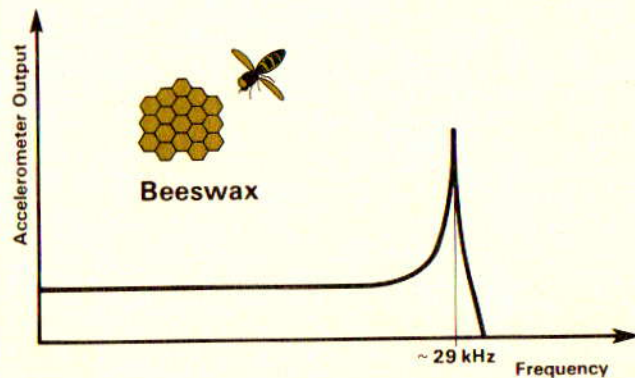
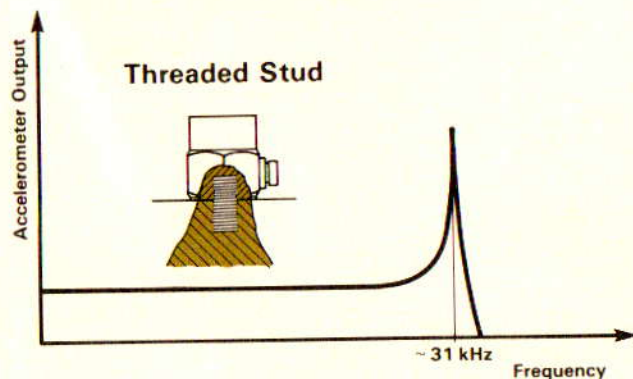

# Mounting the Accelerometer

Where permanent measuring points are to be established on a machine and it is not wished to drill and tap fixing holes, cementing studs can be used. They are attached to the measuring point by means of a hard glue. Epoxy and cyanoacrylate types are recommended as soft glues can considerably reduce the usable frequency range of the accelerometer.

A mica washer and isolated stud are used where the body of the accelerometer should be electrically isolated from the measuring object. This is normally to prevent ground loops, but more about that under "Environmental Influences". A thin slice should be peeled from the thick mica washer supplied. This fixing method also gives good results, the resonance frequency of the test accelerometer only being reduced to about 28 kHz.

A permanent magnet is a simple attachment method where the measuring point is a flat magnetic surface. It also electrically isolates the accelerometer. This method reduced the resonant frequency of the test accelerometer to about 7 kHz and consequently cannot be used for measurements much above 2 kHz. The holding force of the magnet is sufficient for vibration levels up to 1000 to 2000  $m/s^2$  depending on the size of the accelerometer.

A hand-held probe with the accelerometer mounted on top is very convenient for quick-look survey work, but can give gross measuring errors because of the low overall stiffness. Repeatable results cannot be expected. A low-pass filter should be used to limit the measuring range at about 1000 Hz.

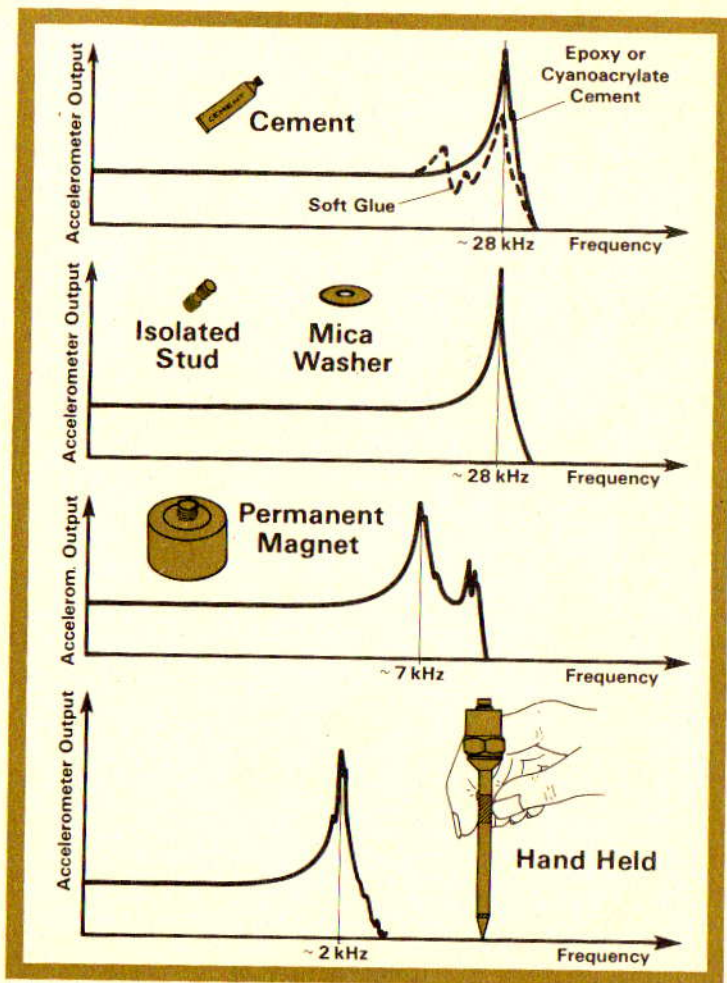

# The Influence of Environment — General

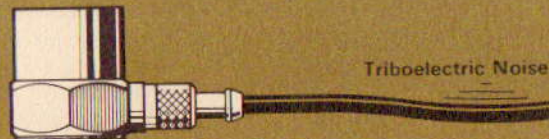
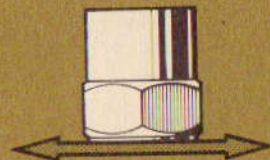
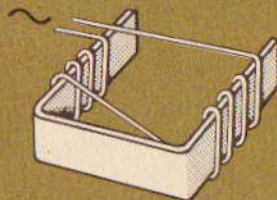
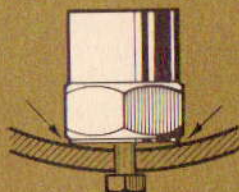
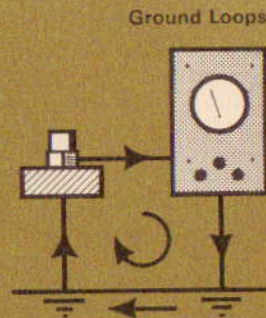
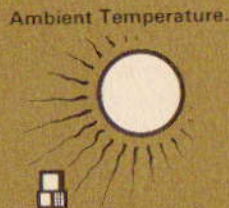

Modern accelerometers and accelerometer cables are designed to have the minimum possible sensitivity to the many external influences shown on the drawing. Nevertheless, in the more severe environments special accelerometers are sometimes necessary. Let us look at the various factors in turn.

## Environmental Influences — Temperature

Typical general purpose accelerometers can tolerate temperatures up to 250°C. At higher temperatures the piezoelectric ceramic will begin to depolarize so that the sensitivity will be permanently altered. Such an accelerometer may still be used after recalibration if the depolarization is not too severe. For temperatures up to 400°C, accelerometers with a special piezoelectric ceramic are available.

All piezoelectric materials are temperature dependent so that any change in the ambient temperature will result in a change in the sensitivity of the accelerometer. For this reason all B & K accelerometers are delivered with a sensitivity versus temperature calibration curve so that measured levels can be corrected for the change in accelerometer sensitivity when measuring at temperatures significantly higher or lower than 20°C.

Piezoelectric accelerometers also exhibit a varying output when subjected to small temperature fluctuations, called temperature transients, in the measuring environment. This is normally only a problem where very low level or low frequency vibrations are being measured. Modern shear type accelerometers have a very low sensitivity to temperature transients.

When accelerometers are to be fixed to surfaces with higher temperatures than 250°C, a heat sink and mica washer can be inserted between the base and the measuring surface. With surface temperatures of 350 to 400°C, the accelerometer base can be held below 250°C by this method. A stream of cooling air can provide additional assistance.

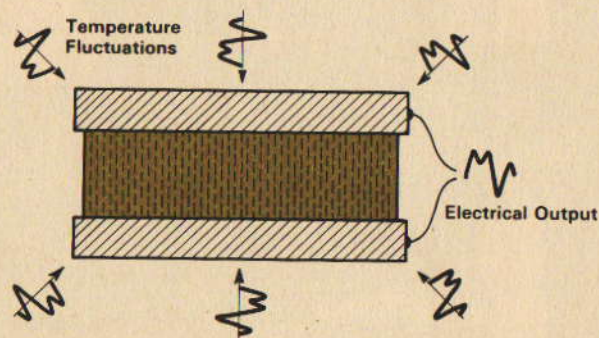
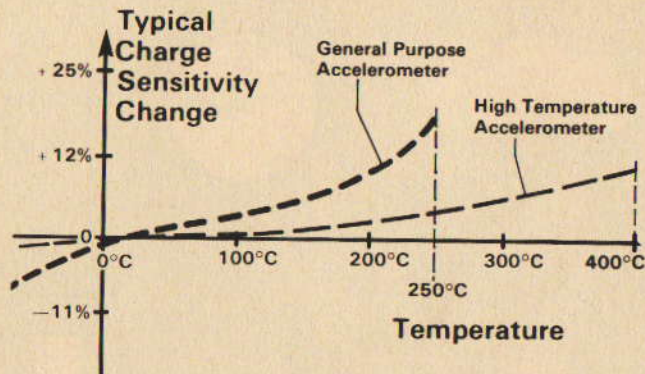

## Environmental Influences — Cable Noise

Since piezoelectric accelerometers have a high output impedance, problems can sometimes arise with noise signals induced in the connecting cable. These disturbances can result from ground loops, triboelectric noise or electromagnetic noise.

**Ground Loop** currents sometimes flow in the shield of accelerometer cables because the accelerometer and measuring equipment are earthed separately. The ground loop is broken by electrically isolating the accelerometer base from the mounting surface by means of an isolating stud and mica washer as already mentioned.

**Tribo-electric Noise** is often induced into the accelerometer cable by mechanical motion of the cable itself. It originates from local capacity and charge changes due to dynamic bending, compression and tension of the layers making up the cable. This problem is avoided by using a proper graphited accelerometer cable and taping or gluing it down as close to the accelerometer as possible.

**Electromagnetic Noise** is often induced in the accelerometer cable when it lies in the vicinity of running machinery. Double shielded cable helps in this respect, but in severe cases a balanced accelerometer and differential preamplifier should be used.

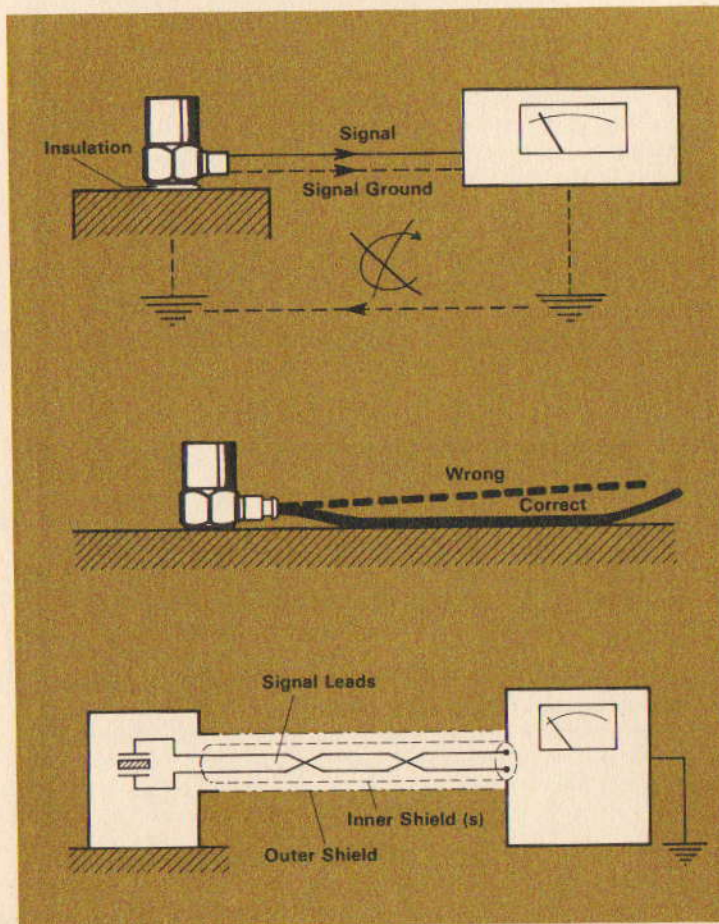

## Other Environmental Influences

**Base Strains:** When an accelerometer is mounted on a surface that is undergoing strain variations, an output will be generated as a result of the strain being transmitted to the sensing element. Accelerometers are designed with thick, stiff bases to minimize this effect: Delta Shear® types have a particularly low base strain sensitivity because the sensing element is mounted on a centre post rather than directly to the accelerometer base.

**Nuclear Radiation:** Most B & K accelerometers can be used under gamma radiation doses of 10 k Rad/h up to accumulated doses of 2 M Rad without significant change in characteristics. Certain accelerometers can be used in heavy radiation with accumulated doses in excess of 100 M Rad.

**Magnetic Fields:** The magnetic sensitivity of piezoelectric accelerometers is very low, normally less than 0,01 to 0,25 m/s<sup>2</sup> per k Gauss in the least favourable orientation of the accelerometer in the magnetic field.

**Humidity:** B & K accelerometers are sealed, either by epoxy bonding or welding to ensure reliable operation in humid environments. For short duration use in liquids, or where heavy condensation is likely, Teflon sealed accelerometer cables are recommended. The accelerometer connector should also be sealed with an acid free room temperature vulcanizing silicon rubber or mastic. Industrial accelerometers with integral cables should be used for permanent use in humid or wet areas.

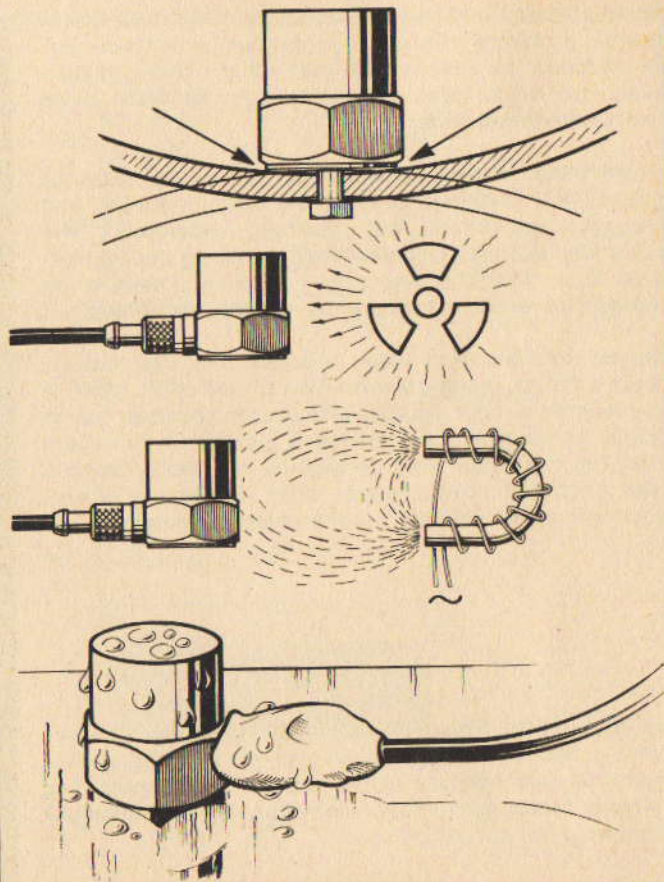

## Other Environmental Influences

**Corrosive Substances:** The materials used in the construction of all Brüel & Kjær accelerometers have a high resistance to most of the corrosive agents encountered in industry.

**Acoustic Noise:** The noise levels present in machinery are normally not sufficiently high to cause any significant error in vibration measurements. Normally, the acoustically induced vibration in the structure on which the accelerometer is mounted is far greater than the airborne excitation.

**Transverse Vibrations:** Piezoelectric accelerometers are sensitive to vibrations acting in directions other than coinciding with their main axis. In the transverse plane, perpendicular to the main axis, the sensitivity is less than 3 to 4% of the main axis sensitivity (typically < 1%). As the transverse resonant frequency normally lies at about 1/3 of the main axis resonant frequency, it should be considered where high levels of transverse vibration are present.

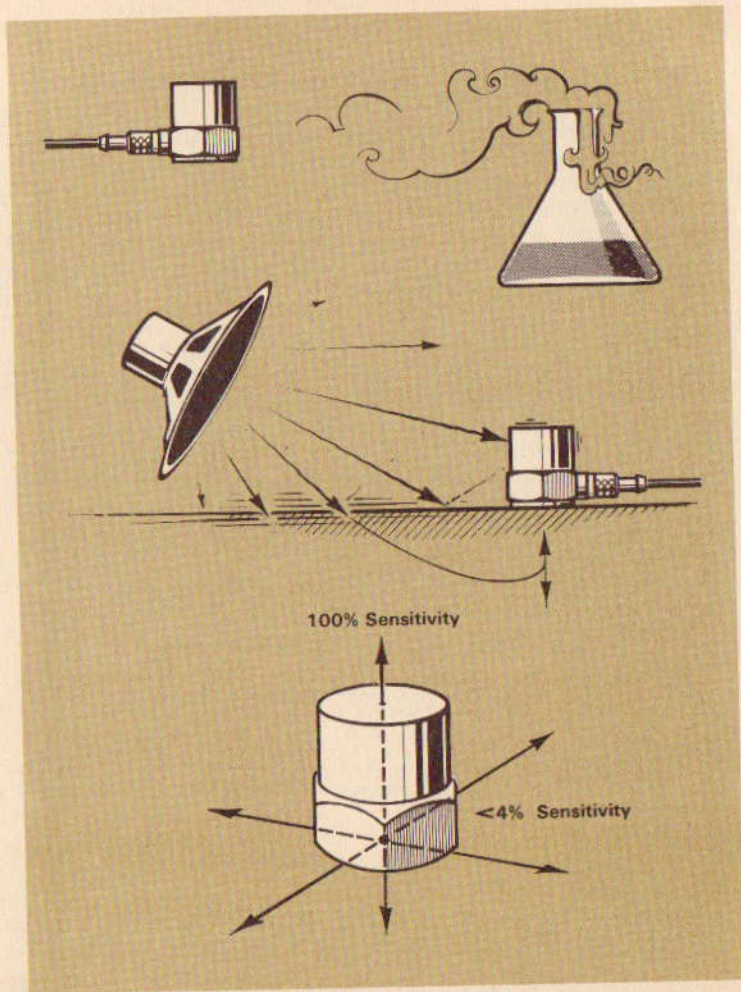

# Accelerometer Calibration

Each Brüel & Kjær accelerometer is supplied individually calibrated from the factory and is accompanied by a comprehensive calibration chart. Where accelerometers are stored and operated within their specified environmental limits, i. e. are not subjected to excessive shocks, temperatures, radiation doses etc. there will be a minimal change in characteristics over a long time period. Tests have shown that characteristics change less than 2%, even over periods of several years.

However, in normal use, accelerometers are often subjected to quite violent treatment which can result in a significant change in characteristics and sometimes even permanent damage. When dropped onto a concrete floor from hand height an accelerometer can be subjected to a shock of many thousands of g. It is wise therefore to make a periodic check of the sensitivity calibration. This is normally sufficient to confirm that the accelerometer is not damaged.

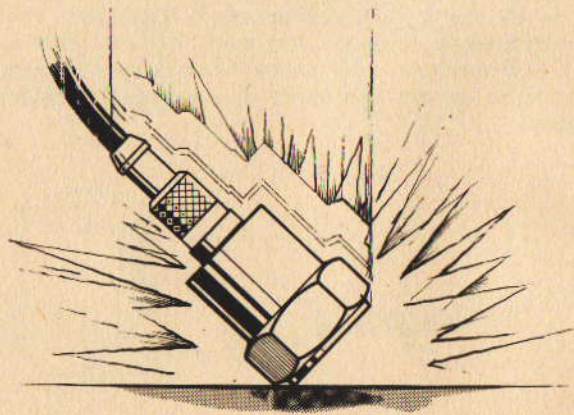
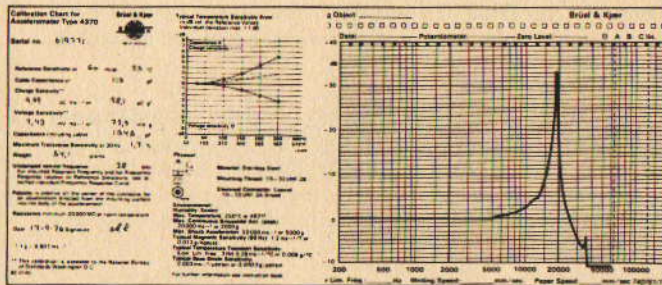

## A Simple Calibrator

The most convenient means of performing a periodic calibration check is by using a B & K battery-powered calibrated vibration source. This has a small built-in shaker table which can be adjusted to vibrate at precisely 1 g (9.81 m/s<sup>2</sup>).

The sensitivity calibration of an accelerometer is checked by fastening it to the shaker table and noting its output when vibrated at 1 g. Alternatively an accelerometer can be reserved for use as a reference. This is mounted on the shaker table with the accelerometer to be calibrated. The ratio of their respective outputs when vibrated will be proportional to their sensitivities, and as the sensitivity of the reference accelerometer is known, the unknown accelerometer's sensitivity can be accurately determined.

An equally useful application for the portable calibrator is the checking of a complete measuring or analyzing set-up before the measurements are made. The measuring accelerometer is simply transferred from the measuring object to the calibrator and vibrated at a level of 1 g. The meter readout can be checked and if a level or tape recorder is being used, the 1 g calibration level can be recorded for future reference.

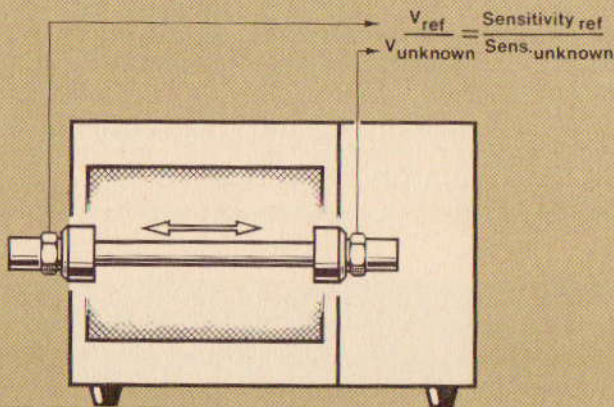
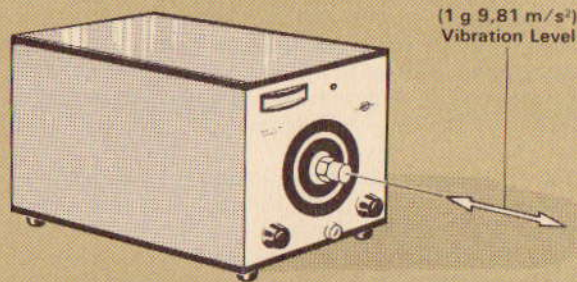

# Force and Impedance Measurements

Force transducers are used in mechanical-dynamics measurements together with accelerometers to determine the dynamic forces in a structure and the resulting vibratory motions. The parameters together describe the mechanical impedance of the structure.

The force transducer also uses a piezoelectric element, which when compressed gives an electrical output proportional to the force transmitted through it. The force signals can be processed and measured with exactly the same instrumentation used with accelerometers.

For point impedance measurements on very light structures, the accelerometer and force transducer can be combined into a single unit called an impedance head. Most impedance measurements, however, are performed using a separate accelerometer and force transducer.

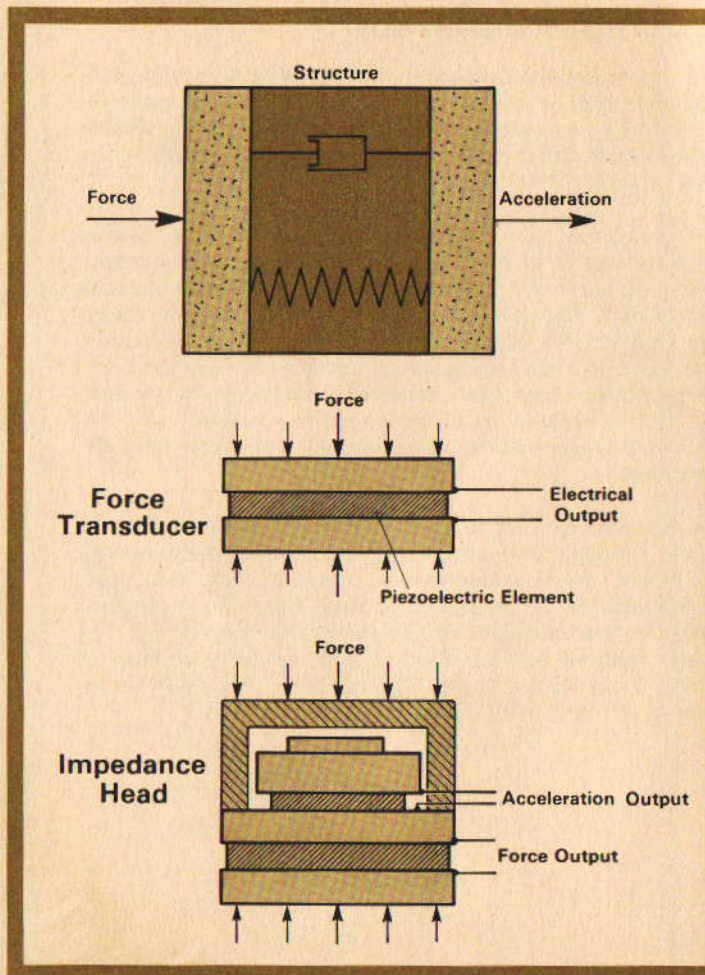

# Logarithmic Scales and Decibels

We often plot frequency on a logarithmic scale. This has the effect of expanding the lower frequencies and compressing the higher frequencies on the chart, thus giving the same percentage resolution over the whole width of the chart and keeping its size down to reasonable proportions.

Logarithmic scales are also used to plot vibration amplitudes; this enables the decibel scale to be used as a help in comparing levels. The decibel (dB) is the ratio of one level with respect to a reference level, and therefore has no dimensions. But in order to quote absolute vibration levels, the reference level must be stated.

For example, we can say that one vibration level is 10 dB greater than another level without any further explanation, but if we wish to say that a vibration level is 85 dB we have to refer it to a reference level. We should say therefore, that the vibratory velocity is 85 dB ref.  $10^{-5}$  mm/s. (See chart below).

As yet, standard dB reference levels are not commonly used in vibration measurement. The reference levels recommended by standardisation for vibration work are shown in the table.

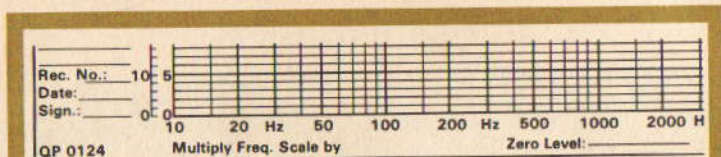

For Amplitude Ratios:

$$N(\text{dB}) = 20 \log_{10} \left( \frac{a}{a_{\text{ref}}} \right)$$

Measured Level

Reference Level

Number of Decibels

## Decibel Reference Levels

	Quantity	Definition	SI ref. level
Amplitude Ratios	Sound Pressure Level	$L_p = 20 \log_{10}(p/p_o)$ dB	$p_o = 2 \times 10^{-5}$ Pa
	Vibratory Acc. Level	$L_a = 20 \log_{10}(a/a_o)$ dB	$a_o = 10^{-5}$ m/s <sup>2</sup>
	Vibratory Vel. Level	$L_v = 20 \log_{10}(v/v_o)$ dB	$v_o = 10^{-8}$ m/s
	Vibratory Displ. Level	$L_d = 20 \log_{10}(d/d_o)$ dB	$d_o = 10^{-11}$ m
	Vibratory Force Level	$L_F = 20 \log_{10}(F/F_o)$ dB	$F_o = 10^{-6}$ N

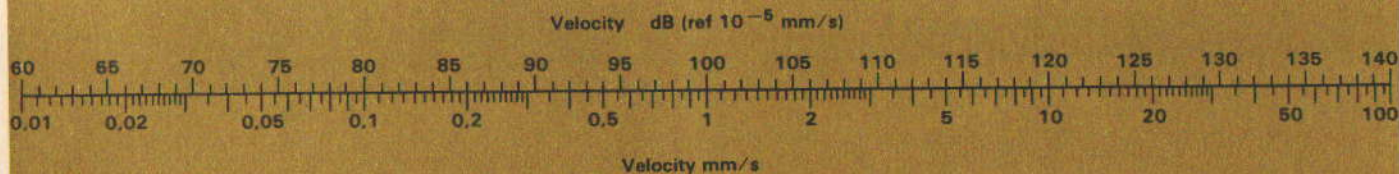

## Why use an Accelerometer Preamplifier?

Direct loading of a piezoelectric accelerometer's output, even by relatively high impedance loads, can greatly reduce the accelerometer's sensitivity as well as limit its frequency response. To minimize these effects the accelerometer output signal is fed through a preamplifier which converts to a much lower impedance, suitable for connection to the relatively low input impedance of measuring and analyzing instrumentation (1).

With measuring amplifiers, analyzers, and voltmeters a separate accelerometer preamplifier is used while vibration meters intended for use with piezoelectric accelerometers normally have the preamplifier built-in.

In addition to the function of impedance conversion, most preamplifiers offer additional facilities for conditioning the signal. For example (2) A calibrated variable gain facility to amplify the signal to a suitable level for input to, for example a tape recorder; (3) A secondary gain adjustment to "normalize" awkward transducer sensitivities; (4) Integrators to convert the acceleration proportional output from accelerometers to either velocity or displacement signals; (5) Various filters to limit the upper and lower frequency response to avoid interference from electrical noise, or signals outside the linear portion of the accelerometer frequency range; (6) Other facilities, such as overload indicator, reference oscillator, and battery condition indicator are also often included.

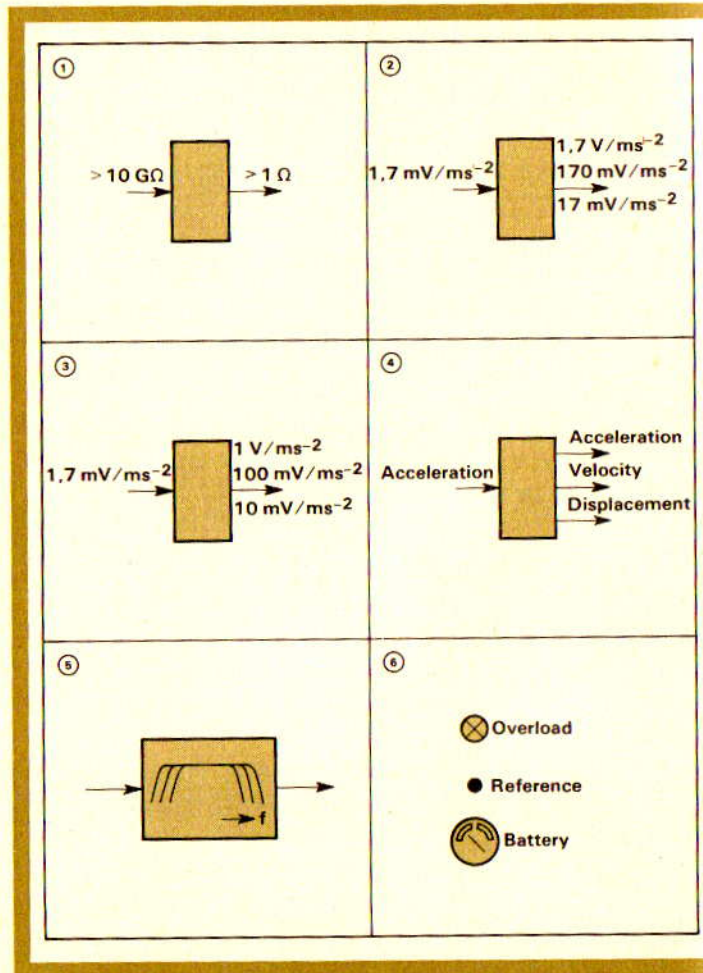

# The Vibration Meter

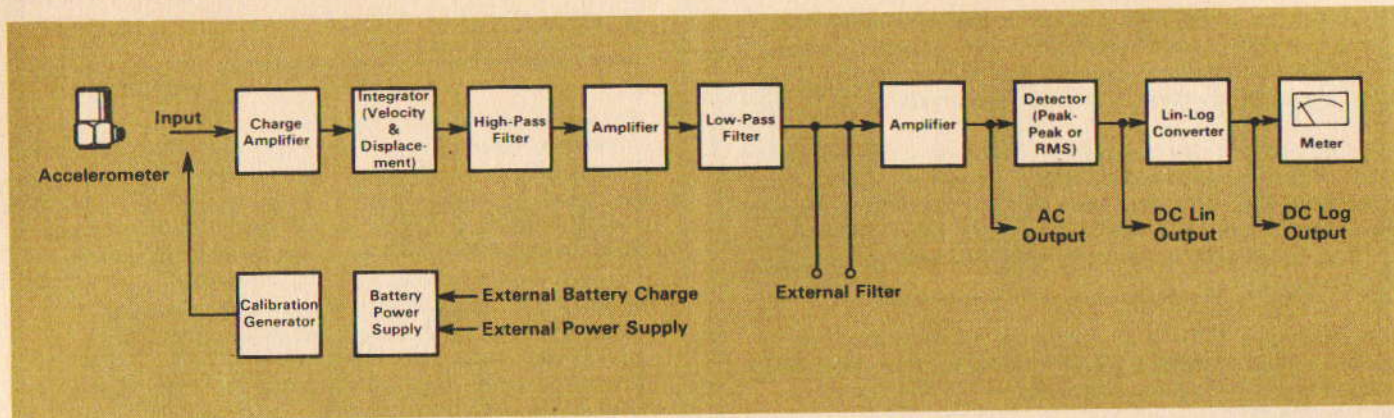

The block diagram shows how a typical modern vibration meter is built-up. The accelerometer is connected to a charge amplifier input stage with an input impedance of several  $G\Omega$ , so that a separate preamplifier is not necessary. With a charge amplifier input, long input cables from the accelerometer, (up to several hundred meters), can be used without any appreciable loss in sensitivity.

An integrator stage allows velocity and displacement parameters, as well as acceleration, to be measured.

The high-pass and low-pass filters can be adjusted so as to limit the frequency range of the instrument to the range of interest only, thus reducing the possibility of interference from high and low frequency noise. After proper amplification the signal is rectified to a DC signal

suitable for displaying on a meter or chart recorder. The detector can either average the RMS level of the signal or register the peak to peak level, and if required can retain the maximum value occurring. This is a particularly useful feature for measuring mechanical shocks and short duration (transient) vibrations.

After passing through a linear to logarithmic converter the signal is displayed on a logarithmic meter scale covering two decades.

An external bandpass filter can be connected to the vibration meter so that frequency analysis can be performed. Output sockets are provided so that the rectified and unrectified vibration signal can be fed to an oscilloscope, tape recorder, or level recorder.

# What is Frequency Analysis?

The vibration meter will give us a single vibration level measured over a wide frequency band. In order to reveal the individual frequency components making up the wide-band signal we perform a frequency analysis.

For this purpose we use a filter which only passes those parts of the vibration signal which are contained in a narrow frequency band. The pass band of the filter is moved sequentially over the whole frequency range of interest so that we obtain a separate vibration level reading for each band.

The filter can consist of a number of individual, contiguous, fixed-frequency filters which are frequency scanned sequentially by switching,

or alternatively, continuous coverage of the frequency range can be achieved with a single tunable filter.

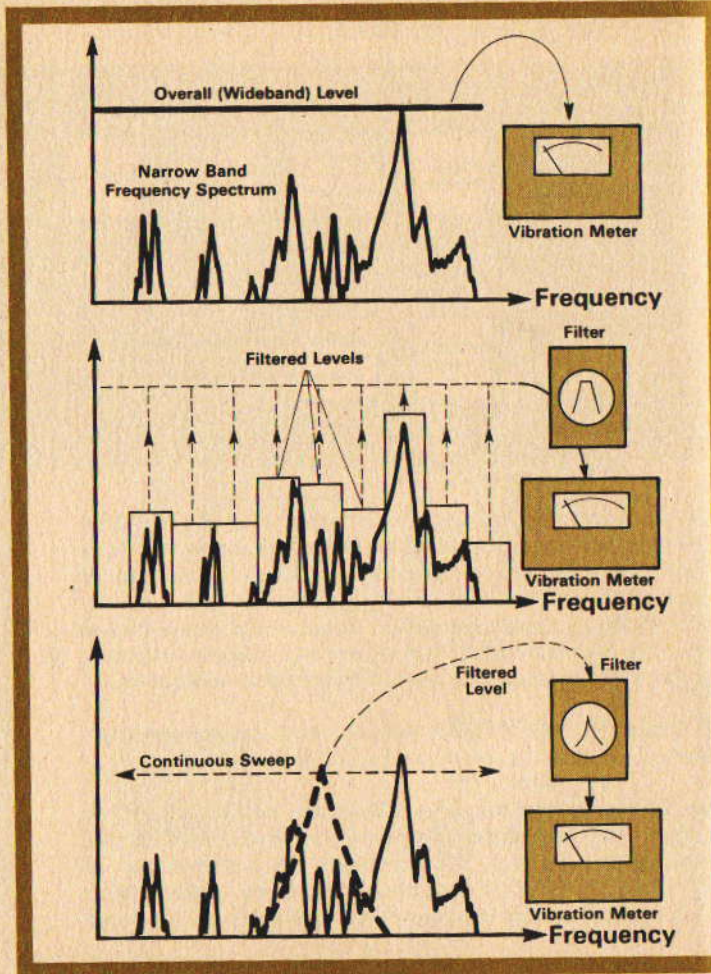

# Constant Bandwidth or Constant Percentage Bandwidth Frequency Analysis?

There are two basic types of filter used for the frequency analysis of vibration signals. The constant bandwidth type filter, where the filter is a constant absolute bandwidth, for example 3 Hz, 10 Hz etc. and the constant percentage bandwidth filter where the filter bandwidth is a constant percentage of the tuned centre frequency, for example 3%, 10% etc. The two drawings show graphically the difference in these two filter types as a function of frequency. Note that the constant percentage bandwidth filter appears to maintain a constant bandwidth, this is because it is plotted on a logarithmic frequency scale which is ideal where a wide frequency range is to be covered. On the other hand, if we show the two types of filter on a linear frequency scale, it is the constant bandwidth filter which shows constant resolution. The constant percentage bandwidth filter plotted on a linear frequency scale shows an increasing bandwidth with increasing frequency which is not really practical.

There is no concise answer to the question of which type of frequency analysis to use. Constant percentage bandwidth analysis tends to match the natural response of mechanical systems to forced vibrations, and allows a wide frequency range to be plotted on a compact chart. It is subsequently the analysis method which is most generally used in vibration measurements.

Constant bandwidth analysis gives better frequency resolution at high frequencies and when plotted on a linear frequency scale is particularly valuable for sorting out harmonic patterns etc.

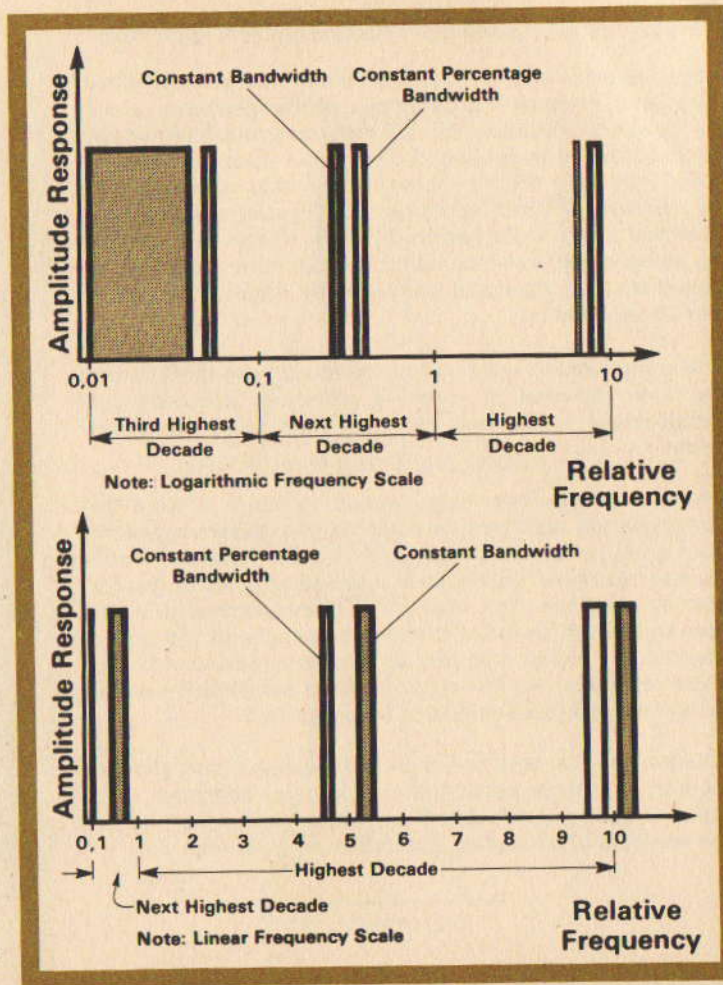

## Filter Bandwidth Considerations

The selectivity of the filter, that is the narrowness of the passband, governs the resolution of the frequency analysis obtained. Vibration spectra from a gearbox are shown in the drawing to the right. The upper spectrum was recorded using a 23% constant percentage bandwidth filter, while the lower spectrum, of the same signal, was recorded using a 3% bandwidth filter. It can be seen that by using a narrower bandwidth filter more detail is obtained so that individual peaks in the vibration spectrum can be isolated.

The disadvantage with narrow bandwidth analysis is that the time required to obtain a particular accuracy gets considerably longer as the filter bandwidth gets narrower.

Because of the long time needed to cover a wide frequency range with narrow bandwidth analyzers a preliminary analysis is often made with a wide filter bandwidth in order to reveal particularly interesting parts of the frequency spectrum. The analyzer is then switched to a narrow bandwidth to make a detailed analysis of the part of interest. At higher frequencies a constant bandwidth analyzer switched to, for example, 3 Hz bandwidth enables extremely detailed analysis to be performed.

To sum up, the best selection of bandwidth and analysis method is in most cases that which gives adequate resolution over the whole frequency range and which allows the analysis to be carried out in the shortest time.

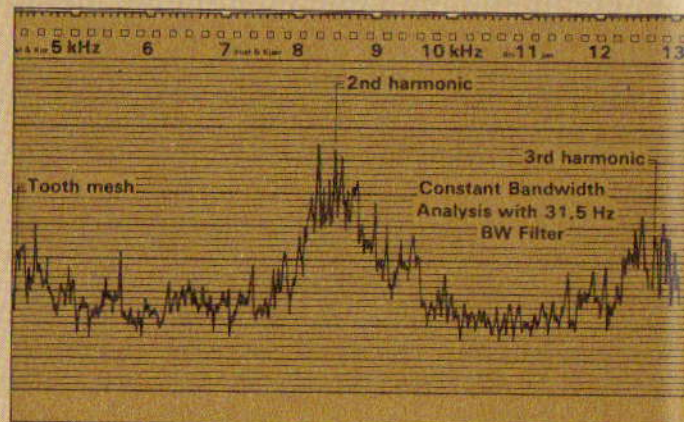
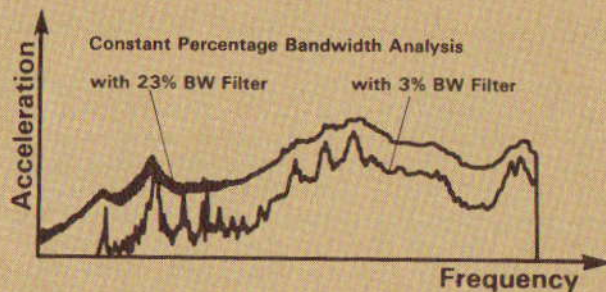

## Defining the Filter Bandwidth

An ideal filter would pass all frequency components occurring within its bandwidth and reject completely all others. In practice, electronic filters have sloping skirts so they do not completely eliminate frequency components lying outside their specified bandwidth. This promotes the important question, how do we specify the filter bandwidth?

Two methods of measuring the filter bandwidth are commonly used. The most often used, defines the bandwidth as the width of the ideal straight sided filter which passes the same amount of power from a white noise source as the filter described. The second definition is the width of the filter characteristic where the filter attenuation is 3 dB lower than the normal transmission level. Only filters with a relatively poor selectivity will have a 3 dB bandwidth substantially different from the effective noise bandwidth.

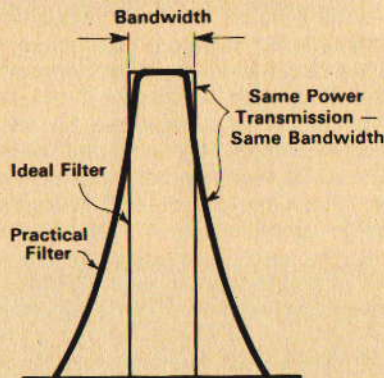

**Effective Noise Bandwidth**

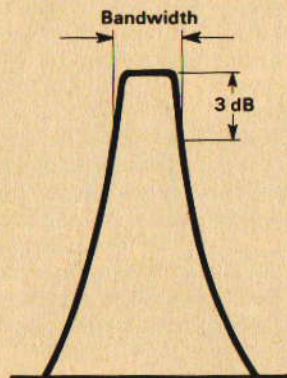

**3 dB Bandwidth**

# Measuring Instrumentation

A portable, general purpose vibration meter as described on p. 27 will usually be the most convenient measuring instrument to use but vibration measurements can also be made in the field with a suitable B & K sound level meter. The microphone is substituted by an integrator adaptor and accelerometer to enable the meter to measure the RMS level of acceleration, velocity and displacement. However these meters do not have the convenience of a charge amplifier input and need to be calibrated separately for each measuring parameter. Battery operated filters can be added to enable octave, third-octave, and narrow bandwidth analysis to be performed.

Mains-operated laboratory oriented instrumentation offers greater versatility, especially in the detailed analysis and data reduction spheres. A basic measuring chain would consist of accelerometer, preamplifier, and a measuring amplifier, possibly with an external filter. The measuring amplifier and filter are often combined into one instrument which is called a Frequency Analyzer or Spectrometer.

The ultimate in operating convenience and analysis speed is obtained with a real-time analyzer, where a large number of parallel frequency bands are evaluated almost instantaneously and shown on a continuously updated display screen. Real-time analyzers are usually equipped with a digital output and remote control facilities so that they can be connected to a tape punch, computer etc., to make fully automatic analysis systems.

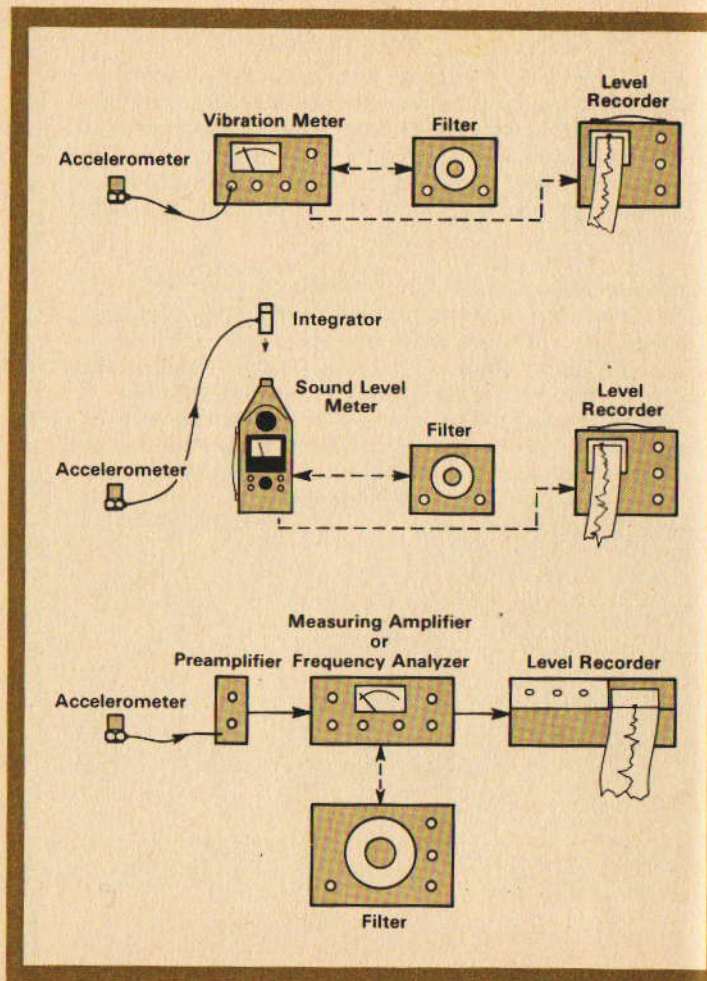

## Recording Results

Where more than a few vibration measurements are made, or frequency analyses are performed, it is a severe drawback to have to manually plot results on a record sheet. The use of a level recorder will facilitate the automatic recording of time and frequency spectra on a precalibrated paper chart. Here again we can choose between small battery operated instruments intended for use with portable vibration analysis equipment, or mains operated recorders which have the additional facilities required to take full advantage of laboratory oriented analysis equipment.

Tape recorders are widely used in vibration measurements to collect data in the field for later analysis in the laboratory. By replaying the tape at a higher speed, very low frequency signals can be brought into the frequency range of ordinary frequency analyzers. Speeding up the tape replay is also used to reduce frequency analysis time.

Where the signal recorded is rather short in duration, for example mechanical shocks, or the vibration signal recorded when a train passes over a bridge, normal sequential analysis is not possible due to the short sample of signal available. In this case, the piece of recording tape bearing the signal is made into a continuous loop so that on replay it appears as a periodic signal, which can be analyzed in the normal way.

A digital recorder is also available which will capture short duration signals and reproduce them when desired in almost any speed transformation ratio.

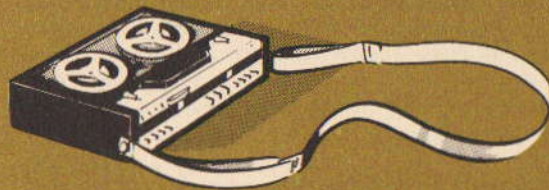
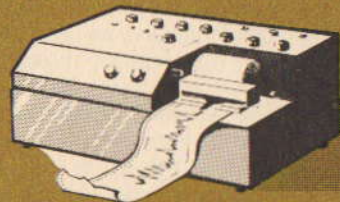
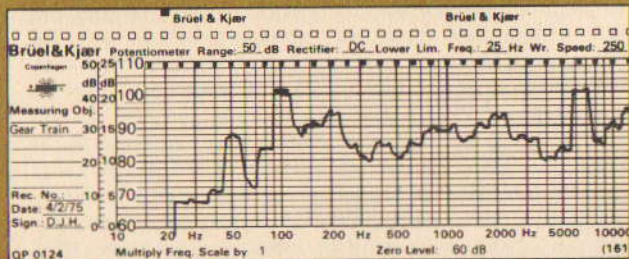

## Using Vibration Measurements

Single, wide frequency band vibration measurements are a useful quick-look vibration indicator, which can be used for example when evaluating the general condition of a machine or the effectiveness of vibration isolation measures. The actual level measured will be judged more or less severe by comparison with previously or subsequently measured levels or with published severity criteria. An example of the latter is shown in the drawing, extracted from standards and recommendations for judging the vibration severity of rotating machinery. (ISO 2372 & 2373, German VDI 2056: 1964; British BS 4675: 1971, and German DIN 45665: 1968).

For diagnostic purposes, for example in the course of product development, frequency analysis is necessary. Some frequency components in the vibration frequency spectrum can be immediately related to particular forcing functions, for example, shaft rotation speeds, gear tooth meshing frequencies etc. We will almost always find additional significant frequency components in the spectrum which are also related to the fundamental motions. The most significant are usually harmonics (a multiple) of one of the fundamental frequencies. Harmonics often arise because of distortion of the fundamental frequencies or because the original periodic motion is not purely sinusoidal. If they coincide with the resonant frequencies of other machine elements, then possibly considerable vibration levels can result, which can become a major noise source or result in the transmission of high forces to other machine parts.

With gear wheels, tooth form deflection under load and tooth wear will give rise to a tooth meshing frequency component and harmonics. Furthermore, side band components are often generated around the tooth meshing

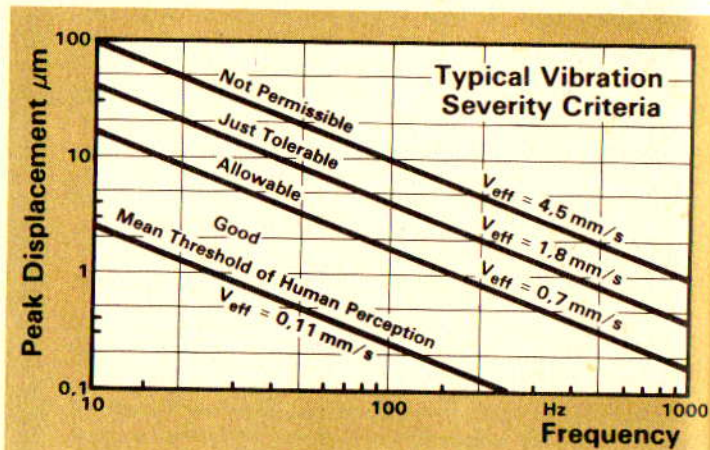

frequency and harmonics, due to periodic variations such as eccentricity. The first upper and lower sidebands will appear at the tooth mesh frequency ( $f_t$ ) plus and minus the gear rotation frequency ( $f_g$ ), the second sidebands at  $f_t \pm 2f_g$ , and so on. Around the tooth mesh harmonics a similar pattern may be present (i. e.  $2f_t \pm f_g$  etc.)

It is often impracticable to alter forcing frequencies (shaft speeds, gear ratios etc.) so other methods of reducing undesirable vibration levels are used. For example, detuning the machine element (altering its resonant frequency) by changing its mass or stiffness; by attenuating the transmission of vibration with isolation materials, or by adding damping materials to reduce the vibration amplitude.

## Vibration as a Machine Condition Indicator

Machines seldom break down without warning, the signs of impending failure are usually present long before breakdown makes the machine unusable. Machine troubles are almost always characterised by an increase in vibration level which can be measured on some external surface of the machine and thus act as an indicator. The bathtub curve shown is a typical plot of vibration level against time that demonstrates this effect. With normal preventive maintenance, repairs are carried out at fixed intervals based on minimum life expectancy for wearing parts. By delaying repair until vibration levels indicate the need, but before breakdown, unnecessary strip-down (which often promotes further faults) and delays in production are avoided.

This "on condition" maintenance of machinery has proven to give appreciable economic advantage by increasing the mean time between shutdown while still preventing the surprise and damaging effects of catastrophic failure during service. These techniques are now widely used especially in the continuous process industries.

The vibration level which may be allowed before undertaking a repair is best determined through experience. At present, general opinion suggests that the "action level" should be set at two to three times (6 to 10 dB above) the vibration level considered normal.

We have already seen that with frequency analysis of vibration signals we are able to locate the source of many of the frequency components present. The frequency spectrum of a machine in a normal running condition

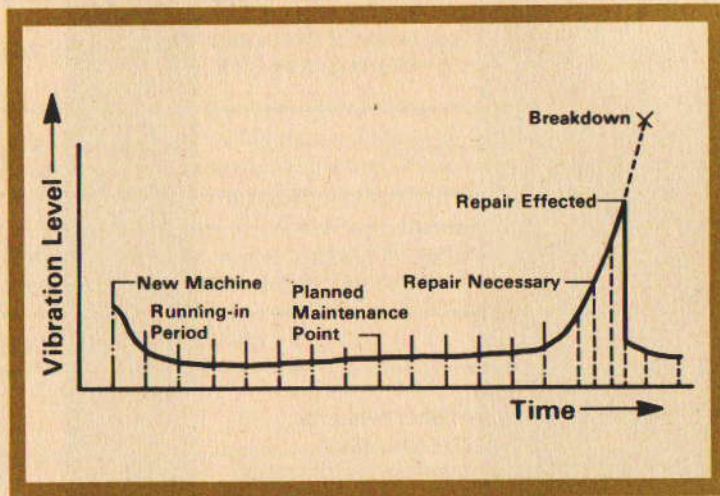

can therefore be used as a reference "signature" for that machine. Subsequent analyses can be compared to this reference so that not only the need for action is indicated but also the source of the fault is diagnosed.

The diagnostic chart on the following two pages will help isolate the cause of excess vibration when the offending frequencies can be discovered through frequency analysis.

# Vibration Trouble Shooting Chart (A)

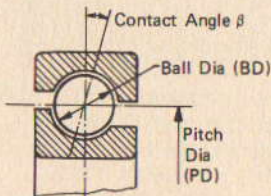
Nature of Fault	Frequency of Dominant Vibration (Hz=rpm/60)	Direction	Remarks
Rotating Members out of Balance	1 x rpm	Radial	A common cause of excess vibration in machinery
Misalignment & Bent Shaft	Usually 1 x rpm Often 2 x rpm Sometimes 3 & 4 x rpm	Radial & Axial	A common fault
Damaged Rolling Element Bearings (Ball, Roller, etc.)	Impact rates for the individual bearing components*  Also vibrations at very high frequencies (20 to 60 kHz)	Radial & Axial	<p>Uneven vibration levels, often with shocks. *Impact-Rates:</p>  <p><b>Impact Rates f (Hz)</b></p> <p>For Outer Race Defect <math>f(\text{Hz}) = \frac{n}{2} f_r (1 - \frac{BD}{PD} \cos \beta)</math></p> <p>For Inner Race Defect <math>f(\text{Hz}) = \frac{n}{2} f_r (1 + \frac{BD}{PD} \cos \beta)</math></p> <p>For Ball Defect <math>f(\text{Hz}) = \frac{PD}{BD} f_r (1 - \frac{BD}{PD})^2 \cos^2 \beta</math></p> <p><math>n</math> = number of balls or rollers <math>f_r</math> = relative rev./s between inner &amp; outer races</p>
Journal Bearings Loose in Housings	Sub-harmonics of shaft rpm, exactly 1/2 or 1/3 x rpm	Primarily Radial	Looseness may only develop at operating speed and temperature (eg. turbomachines).
Oil Film Whirl or Whip in Journal Bearings	Slightly less than half shaft speed (42% to 48%)	Primarily Radial	Applicable to high-speed (eg. turbo) machines.

740561

## Vibration Trouble Shooting Chart (B)

Nature of Fault	Frequency of Dominant Vibration (Hz=rpm/60)	Direction	Remarks
Hysteresis Whirl	Shaft critical speed	Primarily Radial	Vibrations excited when passing through critical shaft speed are maintained at higher shaft speeds. Can sometimes be cured by checking tightness of rotor components
Damaged or worn gears	Tooth meshing frequencies (shaft rpm x number of teeth) and harmonics	Radial & Axial	Sidebands around tooth meshing frequencies indicate modulation (eg. eccentricity) at frequency corresponding to sideband spacings. Normally only detectable with very narrow-band analysis.
Mechanical Looseness	2 x rpm		
Faulty Belt Drive	1, 2, 3 & 4 x rpm of belt	Radial	
Unbalanced Reciprocating Forces and Couples	1 x rpm and/or multiples for higher order unbalance	Primarily Radial	
Increased Turbulence	Blade & Vane passing frequencies and harmonics	Radial & Axial	Increasing levels indicate increasing turbulence.
Electrically Induced Vibrations	1 x rpm or 1 or 2 times synchronous frequency	Radial & Axial	Should disappear when turning off the power.

## Vibration and the Human Body

It has long been recognized that the effects of direct vibration on the human body can be serious. Workers can be affected by blurred vision, loss of balance, loss of concentration etc. In some cases, certain frequencies and levels of vibration can permanently damage internal body organs.

Researchers have been compiling data over the last 30 years on the physiological effects of vibrating, hand-held power tools. The "white finger" syndrome is well known among forest workers handling chain saws. A gradual degeneration of the vascular and nervous tissue takes place so that the worker loses manipulative ability and feeling in the hands.

Standards are at present under preparation which will recommend maximum allowable vibration spectra at the handles of hand-held power tools.

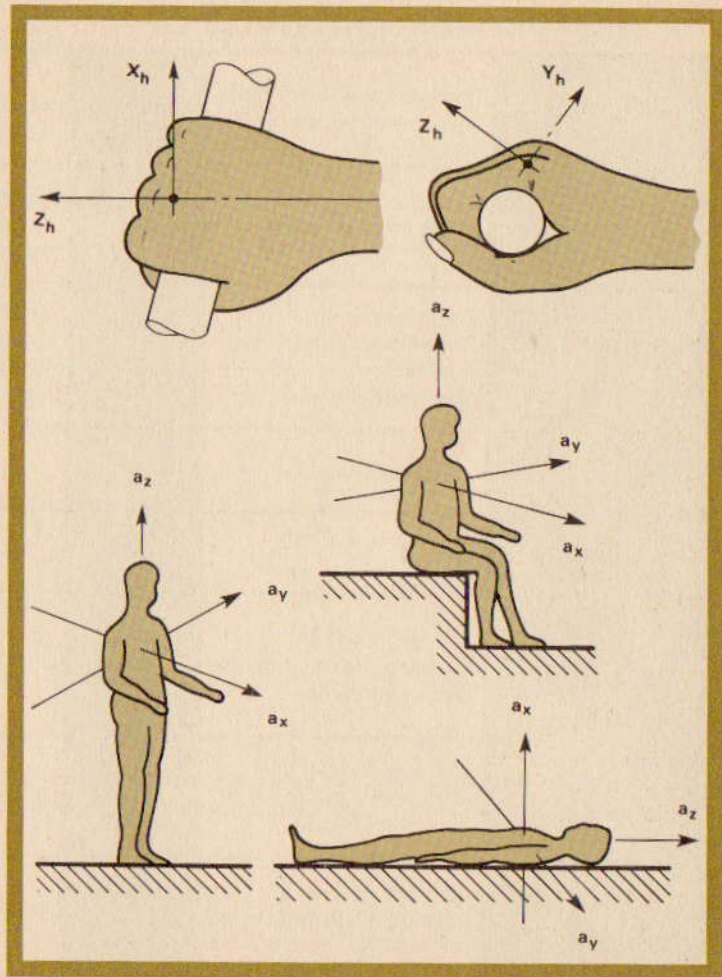

## Vibration and the Human Body

The first published international recommendation concerned with vibration and the human body is ISO 2631 — 1974 which sets out limitation curves for exposure times from 1 minute to 12 hours over the frequency range in which the human body has been found to be most sensitive, namely 1 Hz to 80 Hz. The recommendations cover cases where the human body as a whole is subjected to vibration in three supporting surfaces, namely the feet of a standing person, the buttocks of a seated person and the supporting area of a lying person. Three severity criteria are quoted: 1) A boundary of reduced comfort, applicable to fields such as passenger transportation etc. 2) A boundary for fatigue-decreased efficiency, that will be relevant to vehicle drivers and machine operators, and 3) The exposure limit boundary, which indicates danger to health.

It is interesting to note that in the longitudinal direction, that is feet to head, the human body is most sensitive to vibration in the frequency range 4 to 8 Hz. While in the transverse direction, the body is most sensitive to vibration in the frequency range 1 to 2 Hz.

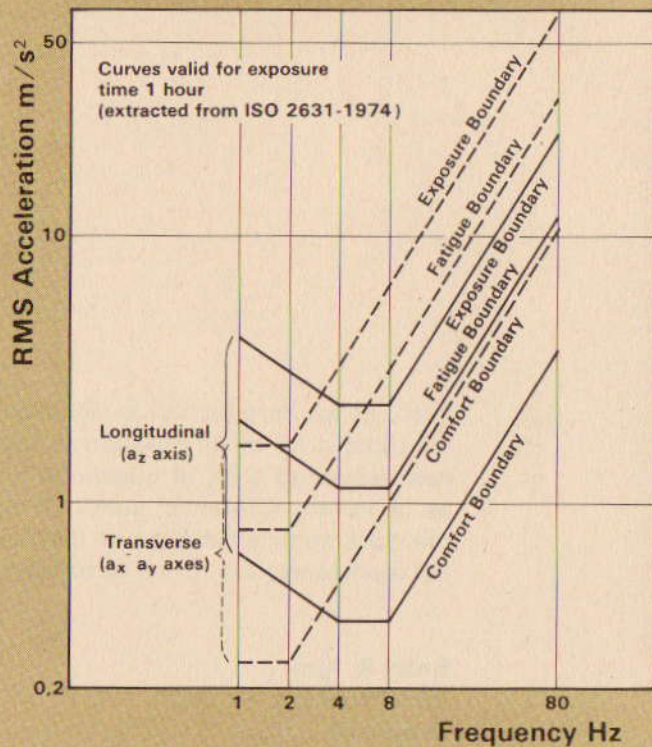

Well, as an introduction to vibration measurements, that was probably quite a lot of information to swallow. But we hope this booklet has answered a lot of questions for you and will continue to serve as a handy reference guide. If you have other questions about measurement techniques or instrumentation, contact one of our local representatives, or write directly to:

**Brüel & Kjær**  
**2850 Nærum**  
**Denmark**

**Brüel & Kjær**

DK-2850 NÆRUM, DENMARK

Telephone: + 45 2 80 05 00

TELEX: 37316 bruka dk

