

Chapter 6

Multidegree of Freedom Systems

6.1 Equations of motion:

$$\begin{aligned} m_1 \ddot{x}_1 &= -k x_1 - 5k(x_1 - x_3) - k(x_1 - x_2) + F_1(t) \\ m_2 \ddot{x}_2 &= -k(x_2 - x_1) - k(x_2 - x_3) + F_2(t) \\ m_3 \ddot{x}_3 &= -5k(x_3 - x_1) - k(x_3 - x_2) - k x_3 + F_3(t) \end{aligned}$$

or

$$\begin{bmatrix} m_1 & 0 & 0 \\ 0 & m_2 & 0 \\ 0 & 0 & m_3 \end{bmatrix} \begin{Bmatrix} \ddot{x}_1 \\ \ddot{x}_2 \\ \ddot{x}_3 \end{Bmatrix} + k \begin{bmatrix} 7 & -1 & -5 \\ -1 & 2 & -1 \\ -5 & -1 & 7 \end{bmatrix} \begin{Bmatrix} x_1 \\ x_2 \\ x_3 \end{Bmatrix} = \begin{Bmatrix} F_1(t) \\ F_2(t) \\ F_3(t) \end{Bmatrix}$$

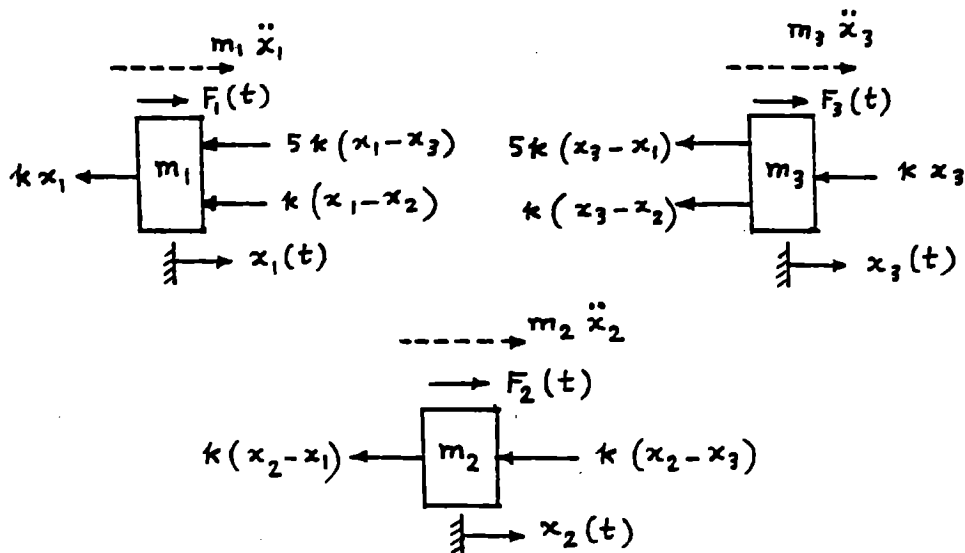

6.2 Equations of motion:

$$\begin{aligned} J_0 \ddot{\theta} &= -2k \left(\frac{\ell}{4} \theta - x_1 \right) \frac{\ell}{4} - c \left(\frac{\ell}{4} \dot{\theta} - \dot{x}_1 \right) \frac{\ell}{4} - 3k(\theta \ell) \ell + M_t \\ 2m \ddot{x}_1 &= -2k \left(x_1 - \frac{\ell}{4} \theta \right) - c \left(\dot{x}_1 - \frac{\ell}{4} \dot{\theta} \right) - k(x_1 - x_2) + F_1 \\ m \ddot{x}_2 &= -k(x_2 - x_1) + F_2 \end{aligned}$$

$$\text{where } J_0 = \frac{1}{3} (2m) \ell^2 = \frac{2}{3} m \ell^2$$

These equations can be stated in matrix form as:

$$\begin{bmatrix} \frac{2}{3} m \ell^2 & 0 & 0 \\ 0 & 2m & 0 \\ 0 & 0 & m \end{bmatrix} \begin{Bmatrix} \ddot{\theta} \\ \ddot{x}_1 \\ \ddot{x}_2 \end{Bmatrix} + \begin{bmatrix} \frac{c \ell^2}{16} & -\frac{c \ell}{4} & 0 \\ -\frac{c \ell}{4} & c & 0 \\ 0 & 0 & 0 \end{bmatrix} \begin{Bmatrix} \dot{\theta} \\ \dot{x}_1 \\ \dot{x}_2 \end{Bmatrix} + \begin{bmatrix} \frac{25 k \ell^2}{8} & -\frac{k \ell}{2} & 0 \\ -\frac{k \ell}{2} & 3k & -k \\ 0 & -k & k \end{bmatrix} \begin{Bmatrix} \theta \\ x_1 \\ x_2 \end{Bmatrix} = \begin{Bmatrix} M_t \\ F_1 \\ F_2 \end{Bmatrix}$$

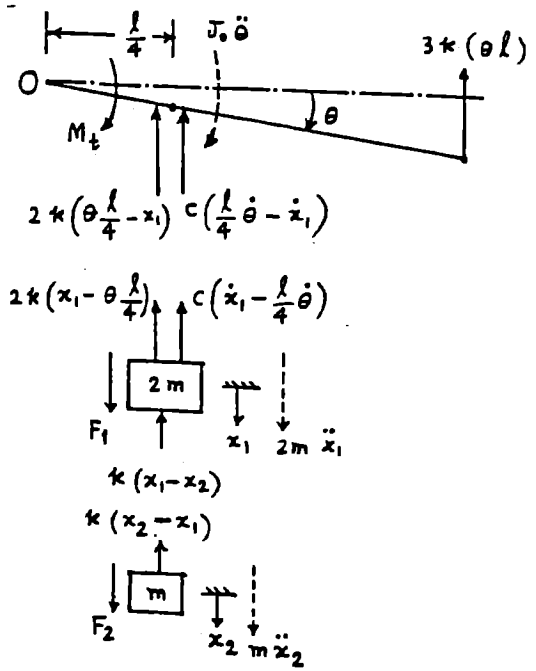

6.3

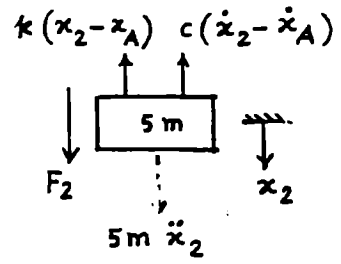
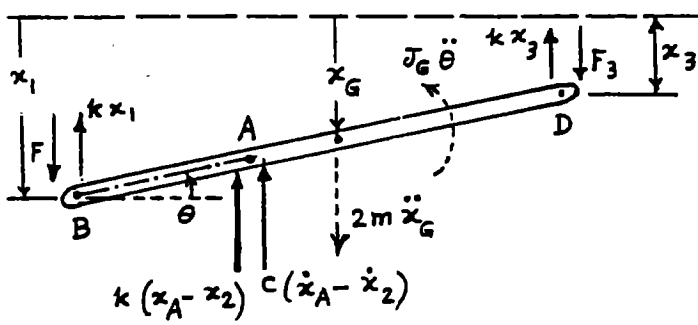

Equation of motion for rotation about B:

$$J_G \ddot{\theta} - 2m \ddot{x}_G \left(\frac{5\ell}{2} \right) = k x_3 (5\ell) - F_3 (5\ell) + k (x_A - x_2) (2\ell) + c (\dot{x}_A - \dot{x}_2) (2\ell) \tag{1}$$

Equation of motion for rotation about D:

$$J_G \ddot{\theta} + 2m \ddot{x}_G \left(\frac{5\ell}{2} \right) = -k x_1 (5\ell) + F_1 (5\ell) - k (x_A - x_2) (3\ell) - c (\dot{x}_A - \dot{x}_2) (3\ell) \tag{2}$$

Equation of motion of mass 5m in vertical direction:

$$5m \ddot{x}_2 = -k (x_2 - x_A) - c (\dot{x}_2 - \dot{x}_A) + F_2 \tag{3}$$

Noting that

$$J_G = \frac{1}{12} (2m) (5\ell)^2 = \frac{25}{6} m \ell^2 ; \quad \theta = \frac{x_1 - x_3}{5\ell} ; \quad x_G = \frac{x_1 + x_3}{2}$$

$$\text{and } x_A = x_1 - 2\ell \theta = \frac{3}{5} x_1 + \frac{2}{5} x_3$$

Eqs. (1) to (3) can be rewritten as:

$$\frac{m}{3} \ddot{x}_1 + \frac{2}{3} m \ddot{x}_3 + \frac{29}{25} k x_3 + \frac{6}{25} k x_1 - \frac{2}{5} k x_2 + \frac{6}{25} c \dot{x}_1 + \frac{4}{25} c \dot{x}_3 - \frac{2}{5} c \dot{x}_2 = F_3 \quad (4)$$

$$\frac{2}{3} m \ddot{x}_1 + \frac{m}{3} \ddot{x}_3 + \frac{34}{25} k x_1 - \frac{3}{5} k x_2 + \frac{6}{25} k x_3 + \frac{9}{25} c \dot{x}_1 - \frac{3}{5} c \dot{x}_2 + \frac{6}{25} c \dot{x}_3 = F_1 \quad (5)$$

$$5 m \ddot{x}_2 - \frac{3}{5} k x_1 + k x_2 - \frac{2}{5} k x_3 - \frac{3}{5} c \dot{x}_1 + c \dot{x}_2 - \frac{2}{5} c \dot{x}_3 = F_2 \quad (6)$$

6.4

Equations of motion:

Mass M: $M \ddot{x}_1 = -k x_1 + T - 2k(x_1 - x_3 - r\theta) + F_1$ (1)

Mass m: $m \ddot{x}_3 = -3k x_3 + 2k(x_1 - x_3 - r\theta) + F_3$ (2)

Mass 3m: $3m \ddot{x}_2 = F_2 - T$ (3)

Rotation of pulley:

$$J_0 \ddot{\theta} = T(3r) + r(2k)(x_1 - x_3 - r\theta) \quad (4)$$

Noting that

$$\theta = \frac{x_2 - x_1}{3r}$$

and

$$x_1 - x_3 - r\theta = x_1 - x_3 - r \left(\frac{x_2 - x_1}{3r} \right) = \frac{4}{3} x_1 - \frac{1}{3} x_2 - x_3$$

Eq. (4) can be used to find the tension T as:

$$T = \left(\frac{J_0}{9r^2} \right) (\ddot{x}_2 - \ddot{x}_1) - \frac{8}{9} k x_1 + \frac{2}{9} k x_2 + \frac{2}{3} k x_3 \quad (5)$$

Using the expression of T, Eqs. (1) to (3) can be rewritten as

$$\left(M + \frac{J_0}{9r^2} \right) \ddot{x}_1 - \frac{J_0}{9r^2} \ddot{x}_2 + \frac{41}{9} k x_1 - \frac{8}{9} k x_2 - \frac{8}{3} k x_3 = F_1(t) \quad (6)$$

$$-\frac{J_0}{9r^2} \ddot{x}_1 + \left(3m + \frac{J_0}{9r^2} \right) \ddot{x}_2 - \frac{8}{9} k x_1 + \frac{2}{9} k x_2 + \frac{2}{3} k x_3 = F_2(t) \quad (7)$$

$$m \ddot{x}_3 - \frac{8}{3} k x_1 + \frac{2}{3} k x_2 + 5k x_3 = F_3(t) \quad (8)$$

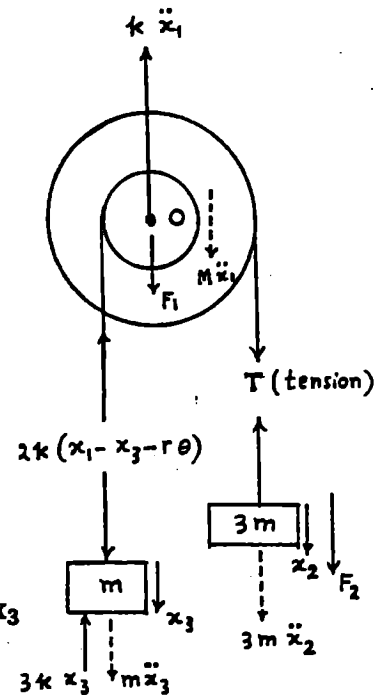

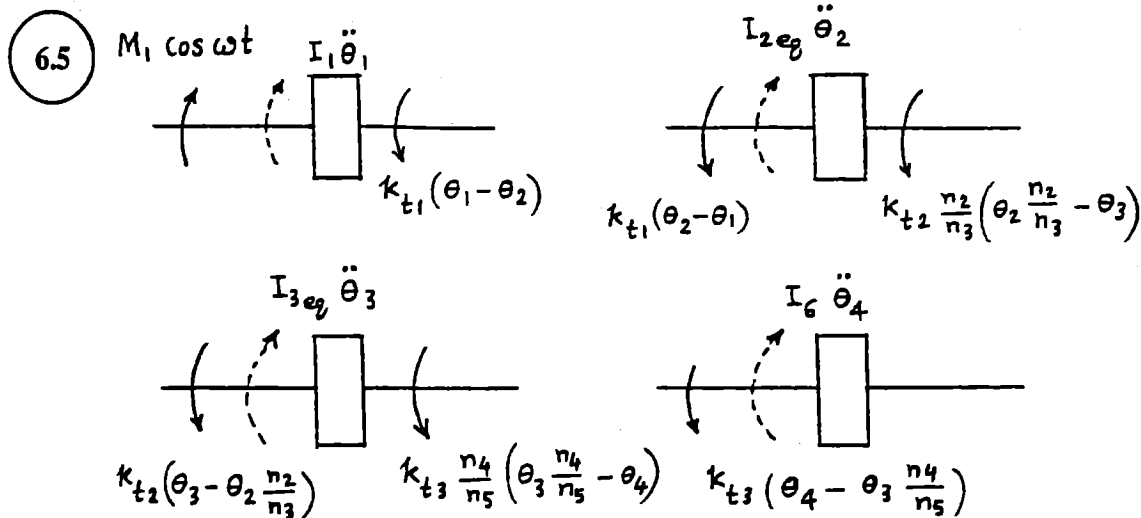

$$I_{2eq} = I_2 + I_3 \left(\frac{n_2}{n_3} \right)^2 ; I_{3eq} = I_4 + I_5 \left(\frac{n_4}{n_5} \right)^2$$

Equations of motion:

$$I_1 \ddot{\theta}_1 + k_{t1} (\theta_1 - \theta_2) = M_1 \cos \omega t$$

$$\left(I_2 + I_3 \frac{n_2^2}{n_3^2} \right) \ddot{\theta}_2 + k_{t1} (\theta_2 - \theta_1) + k_{t2} \frac{n_2}{n_3} (\theta_2 \frac{n_2}{n_3} - \theta_3) = 0$$

$$\left(I_4 + I_5 \frac{n_4^2}{n_5^2} \right) \ddot{\theta}_3 + k_{t2} (\theta_3 - \theta_2 \frac{n_2}{n_3}) + k_{t3} \frac{n_4}{n_5} (\theta_3 \frac{n_4}{n_5} - \theta_4) = 0$$

$$I_6 \ddot{\theta}_4 + k_{t3} (\theta_4 - \theta_3 \frac{n_4}{n_5}) = 0$$

6.6

$$M \ddot{x}_3 = -c_2 (\dot{x}_3 - \ell_1 \dot{\theta} - \dot{x}_1) - k_2 (x_3 - \ell_1 \theta - x_1)$$

$$-c_2 (\dot{x}_3 + \ell_1 \dot{\theta} - \dot{x}_2) - k_2 (x_3 + \ell_2 \theta - x_2)$$

$$J_G \ddot{\theta} = c_2 (\dot{x}_3 - \ell_1 \dot{\theta} - \dot{x}_1) \ell_1 + k_2 (x_3 - \ell_1 \theta - x_1) \ell_1 - c_2 (\dot{x}_3 + \ell_1 \dot{\theta} - \dot{x}_2) \ell_2 - k_2 (x_3 + \ell_2 \theta - x_2) \ell_2 \quad (2)$$

$$m_1 \ddot{x}_1 = -c_2 (\dot{x}_1 - \dot{x}_3 + \ell_1 \dot{\theta}) - k_2 (x_1 - x_3 + \ell_1 \theta) - c_1 \dot{x}_1 - k_1 x_1 + F_1 \quad (3)$$

$$m_2 \ddot{x}_2 = -c_2 (\dot{x}_2 - \dot{x}_3 - \ell_2 \dot{\theta}) - k_2 (x_2 - x_3 - \ell_2 \theta) - k_1 x_2 - c_1 \dot{x}_2 + F_2 \quad (4)$$

Eqs. (1) to (4) can be rewritten as

$$M_3 \dot{x}_3 + 2 c_2 \dot{x}_3 - c_2 \dot{x}_1 - c_2 \dot{x}_2 + 2 k_2 x_3 + \theta (k_2 \ell_2 - k_2 \ell_1) - k_2 x_1 - k_2 x_2 = 0 \quad (5)$$

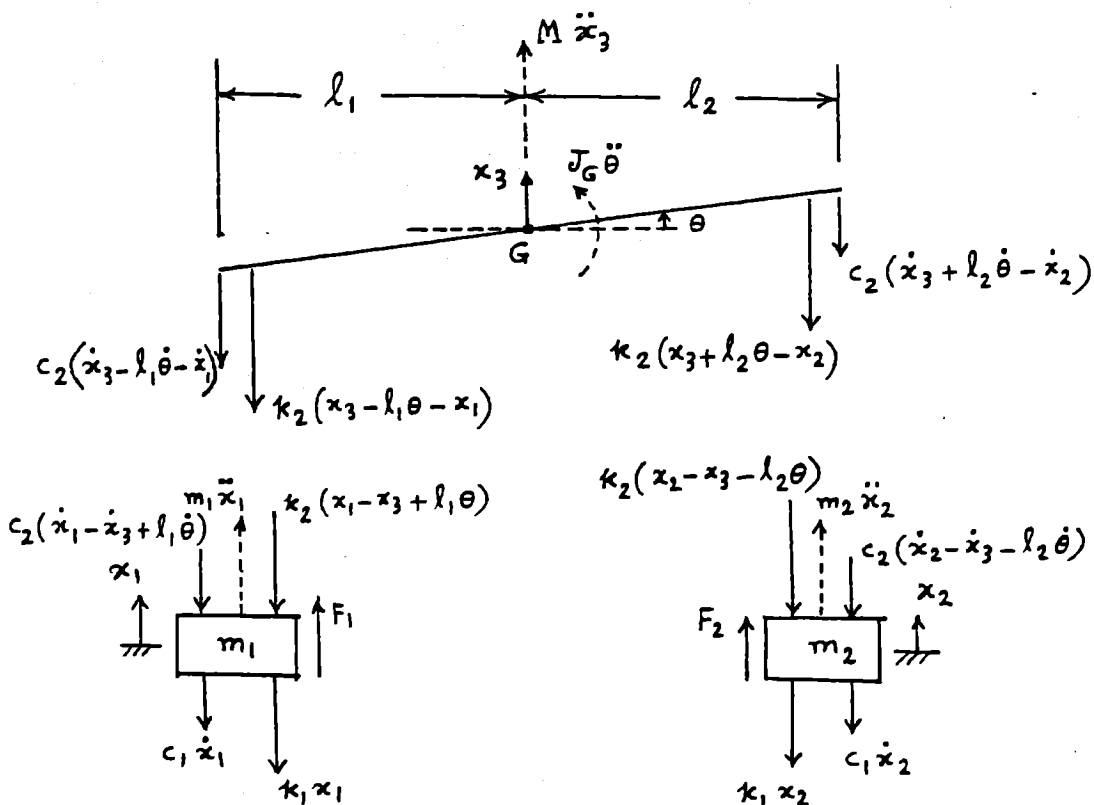

$$J_G \ddot{\theta} + (c_2 l_1^2 + c_2 l_2^2) \dot{\theta} + (-c_2 l_1 + c_2 l_2) \dot{x}_3 + c_2 l_1 \dot{x}_1 - c_2 l_2 \dot{x}_2 + (-k_2 l_1 + k_2 l_2) x_3 + k_2 l_1 x_1 - k_2 l_2 x_2 + (k_2 l_1^2 + k_2 l_2^2) \theta = 0 \quad (6)$$

$$m_1 \ddot{x}_1 + (c_1 + c_2) \dot{x}_1 - c_2 \dot{x}_3 + c_2 l_1 \dot{\theta} + (k_1 + k_2) x_1 - k_2 x_3 + k_2 l_1 \theta = F_1 \quad (7)$$

$$m_2 \ddot{x}_2 + (c_1 + c_2) \dot{x}_2 - c_2 \dot{x}_3 - c_2 l_2 \dot{\theta} + (k_1 + k_2) x_2 - k_2 x_3 - k_2 l_2 \theta = F_2 \quad (8)$$

6.7

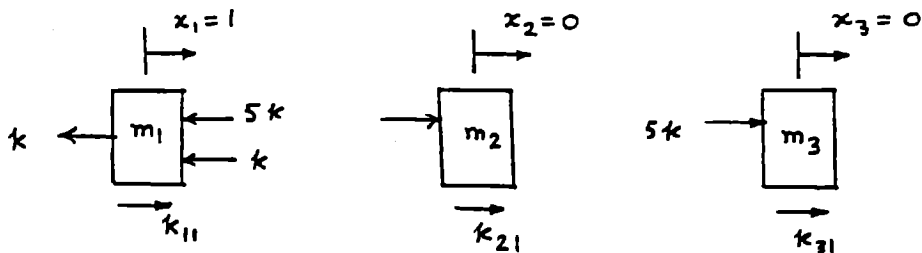

(i) Set $x_1 = 1, x_2 = x_3 = 0$:

Equilibrium of forces:

$$k_{11} - k - 5k - k = 0 \text{ or } k_{11} = 7k ; k_{21} = -k ; k_{31} = -5k$$

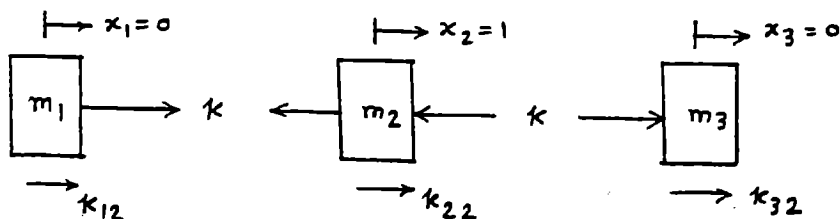

(ii) Set $x_2 = 1, x_1 = x_3 = 0$:

Equilibrium of forces:

$k_{12} = -k ; k_{22} - k - k = 0$ or $k_{22} = 2k ; k_{32} = -k$

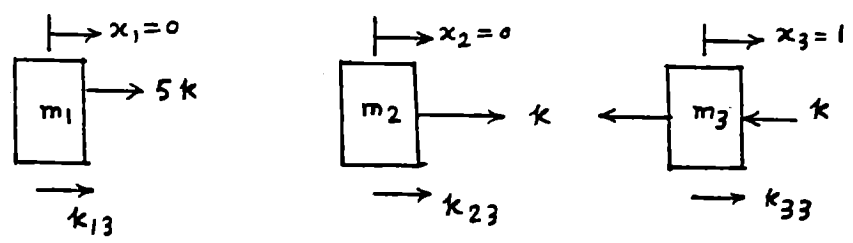

(iii) Set $x_3 = 1, x_1 = x_2 = 0$:

Equilibrium of forces:

$k_{13} = -5k ; k_{23} = -k ; k_{33} = 7k$

$$\therefore [k] = \begin{bmatrix} 7 & -1 & -5 \\ -1 & 2 & -1 \\ -5 & -1 & 7 \end{bmatrix}$$

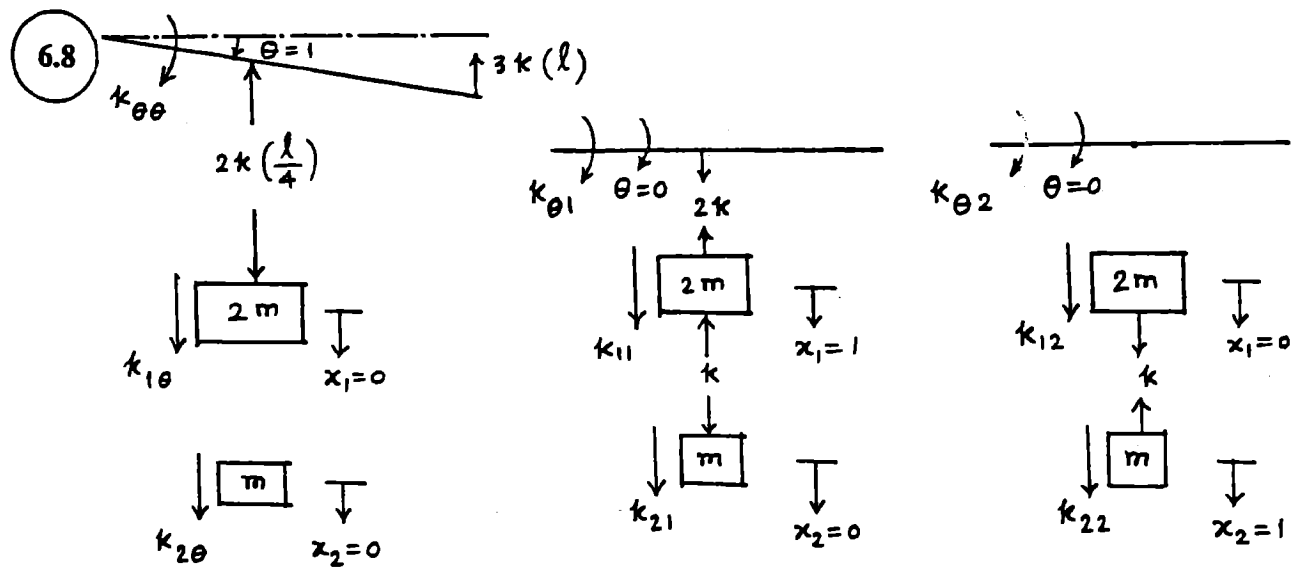

(i) Give $\theta = 1, x_1 = x_2 = 0$:

Equilibrium equations:

$$k_{\theta\theta} = 3k \ell^2 + 2k (\ell/4)^2 = \frac{25}{8} k \ell^2 ; k_{1\theta} = -\frac{k \ell}{2} ; k_{2\theta} = 0$$

(ii) Give $x_1 = 1, \theta = x_2 = 0$:

Equilibrium equations:

$$k_{\theta 1} = -2k (\ell/4) = -\frac{k \ell}{2} ; k_{11} = 2k + k = 3k ; k_{21} = -k$$

(iii) Give $x_2 = 1, \theta = x_1 = 0$:

Equilibrium equations:

$$k_{\theta 2} = 0 ; k_{12} = -k ; k_{22} = k$$

$$\therefore [k] = \begin{bmatrix} \frac{25 k \ell^2}{8} & -\frac{k \ell}{2} & 0 \\ -\frac{k \ell}{2} & 3 k & -k \\ 0 & -k & k \end{bmatrix}$$

6.9

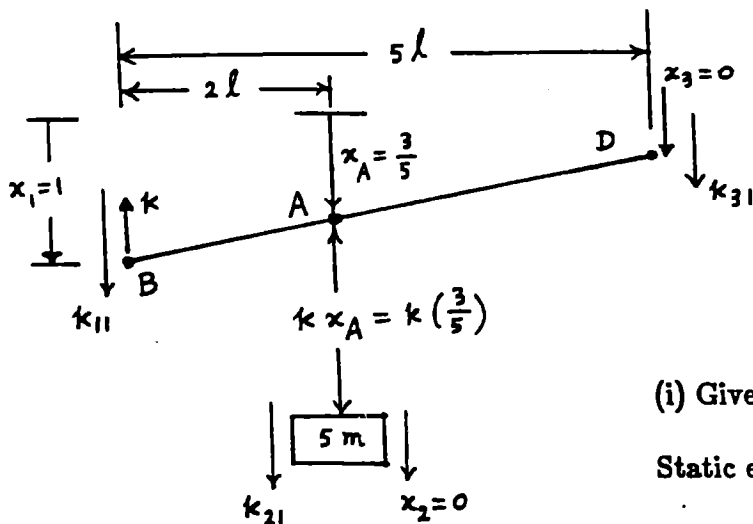

(i) Give $x_1 = 1, x_2 = x_3 = 0$:

Static equilibrium equations:

$$\sum M_B = 0 \text{ or } k_{31} (5 \ell) - \frac{3}{5} k (2 \ell) = 0 \text{ or } k_{31} = \frac{6}{25} k$$

$$\sum M_D = 0 \text{ or } k_{11} (5 \ell) - k (5 \ell) - \frac{3 k}{5} (3 \ell) = 0 \text{ or } k_{11} = \frac{34}{25} k$$

$$\sum F = 0 \text{ at mass } 5m \text{ or } k_{21} + \frac{3}{5} k = 0 \text{ or } k_{21} = -\frac{3}{5} k$$

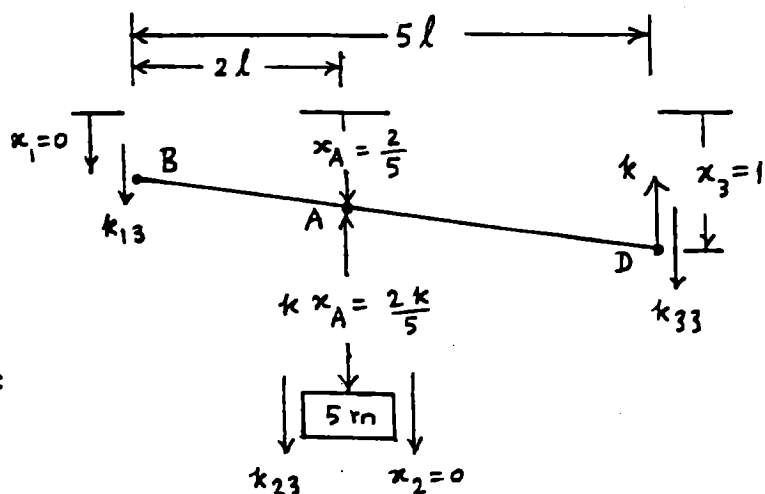

(ii) Give $x_3 = 1, x_1 = x_2 = 0$:

Static equilibrium equations:

$$\sum M_B = 0 \text{ or } k_{33} (5 \ell) - \frac{2 k}{5} (2 \ell) - k (5 \ell) = 0 \text{ or } k_{33} = \frac{29}{25} k$$

$$\sum M_D = 0 \text{ or } k_{13} (5 \ell) - \frac{2k}{5} (3 \ell) = 0 \text{ or } k_{13} = \frac{6}{25} k$$

$$\sum F = 0 \text{ at mass } 5m \text{ or } k_{23} + \frac{2}{5} k = 0 \text{ or } k_{23} = -\frac{2}{5} k$$

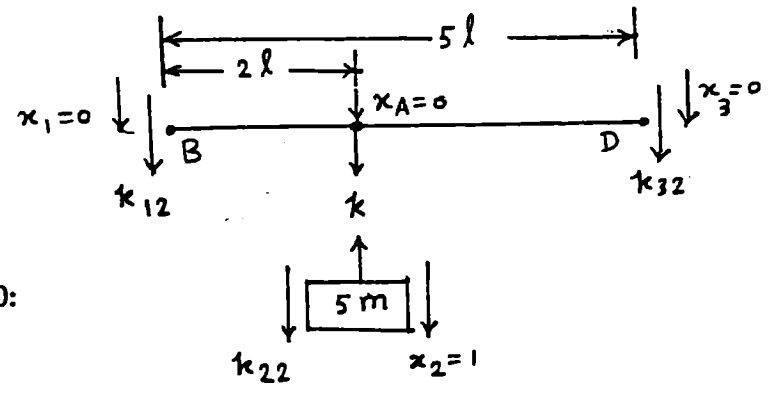

(iii) Give $x_3 = 1, x_1 = x_2 = 0$:

Static equilibrium equations:

$$\sum M_B = 0 \text{ or } k_{32} (5 \ell) + k (2 \ell) = 0 \text{ or } k_{32} = -\frac{2}{5} k$$

$$\sum M_D = 0 \text{ or } k_{12} (5 \ell) + k (3 \ell) = 0 \text{ or } k_{12} = -\frac{3}{5} k$$

$$\sum F = 0 \text{ at mass } 5m \text{ or } k_{22} - k = 0 \text{ or } k_{22} = k$$

$$\therefore [k] = k \begin{bmatrix} \frac{34}{25} & \frac{3}{5} & \frac{6}{25} \\ -\frac{3}{5} & 1 & -\frac{2}{5} \\ \frac{6}{25} & -\frac{2}{5} & \frac{29}{25} \end{bmatrix}$$

6.10

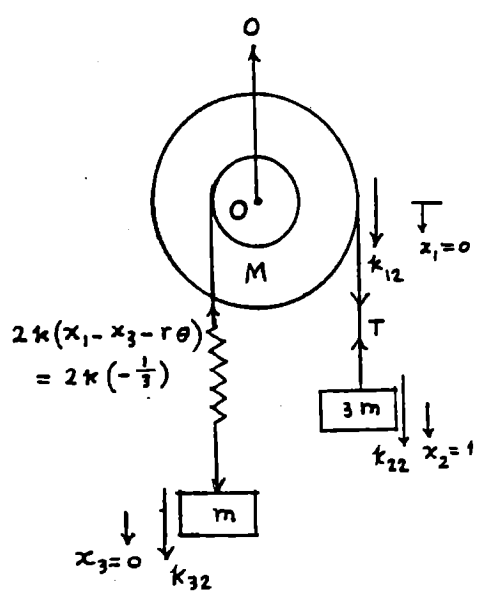
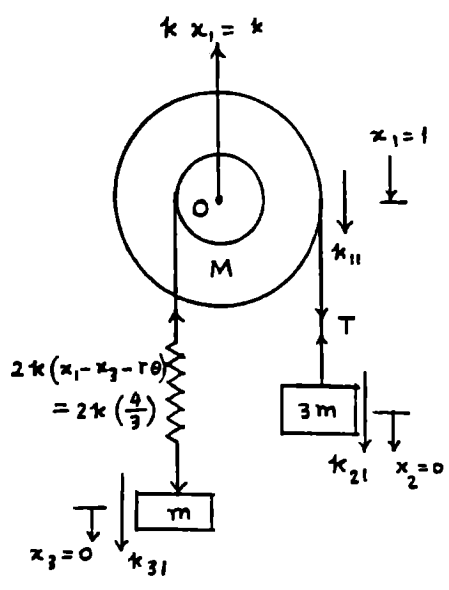

Here $\theta = \frac{x_2 - x_1}{3r}$; $x_1 - x_3 - r\theta = \frac{4}{3} x_1 - \frac{1}{3} x_2 - x_3$

(i) Give $x_1 = 1, x_2 = x_3 = 0$:

$$\sum F = 0 \text{ for mass } M: k_{11} - k + T - \frac{8k}{3} = 0 \quad (1)$$

$$\sum F = 0 \text{ for mass } m: k_{31} + \frac{8k}{3} = 0 \quad (2)$$

$$\sum F = 0 \text{ for mass } 3m: k_{21} = T \quad (3)$$

$$\sum M_0 = 0 \text{ for pulley: } T(3r) + 2k \left(\frac{4}{3} \right) r = 0 \text{ or } T = -\frac{8k}{9} \quad (4)$$

Eqs. (1) to (4) yield:

$$k_{21} = -\frac{8k}{9}, k_{31} = -\frac{8k}{3}, k_{11} = \frac{41}{9}k$$

(ii) Give $x_2 = 1, x_1 = x_3 = 0$:

$$\sum F = 0 \text{ for mass } M: k_{12} + T + \frac{2k}{3} = 0 \quad (5)$$

$$\sum F = 0 \text{ for mass } 3m: k_{22} - T = 0 \quad (6)$$

$$\sum F = 0 \text{ for mass } m: k_{32} - \frac{2k}{3} = 0 \quad (7)$$

$$\sum M_0 = 0 \text{ for pulley: } T(3r) + r \left(-\frac{2k}{3} \right) = 0 \quad (8)$$

Solution of Eqs. (5) to (8) yields:

$$k_{22} = T = \frac{2k}{9}, k_{32} = \frac{2k}{3}, k_{12} = -\frac{8k}{9}$$

(iii) Give $x_3 = 1, x_1 = x_2 = 0$:

$$\sum F = 0 \text{ for mass } M: k_{13} + T - (-2k) = 0 \quad (9)$$

$$\sum F = 0 \text{ for mass } 3m: k_{23} - T = 0 \quad (10)$$

$$\sum F = 0 \text{ for mass } m: k_{33} - 2k - 3k = 0 \quad (11)$$

$$\sum M_0 = 0 \text{ for pulley: } T(3r) + r(-2k) = 0 \quad (12)$$

Solution of Eqs. (9) to (12) gives:

$$k_{33} = 5k, k_{23} = \frac{2k}{3}, k_{13} = -\frac{8k}{3}$$

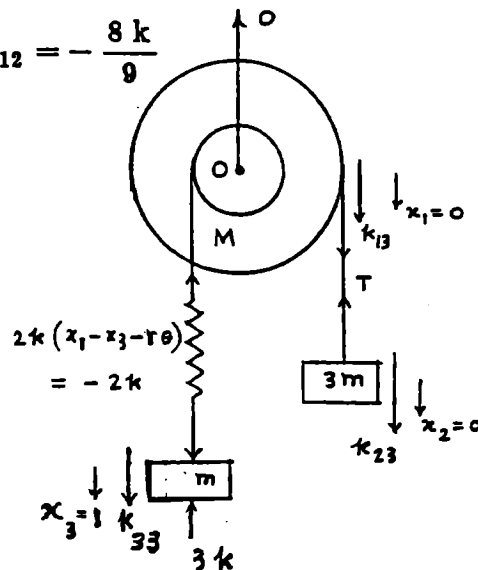

$$\therefore [k] = k \begin{bmatrix} \frac{41}{9} & -\frac{8}{9} & -\frac{8}{3} \\ -\frac{8}{9} & \frac{2}{9} & \frac{2}{3} \\ -\frac{8}{3} & \frac{2}{3} & 5 \end{bmatrix}$$

6.11

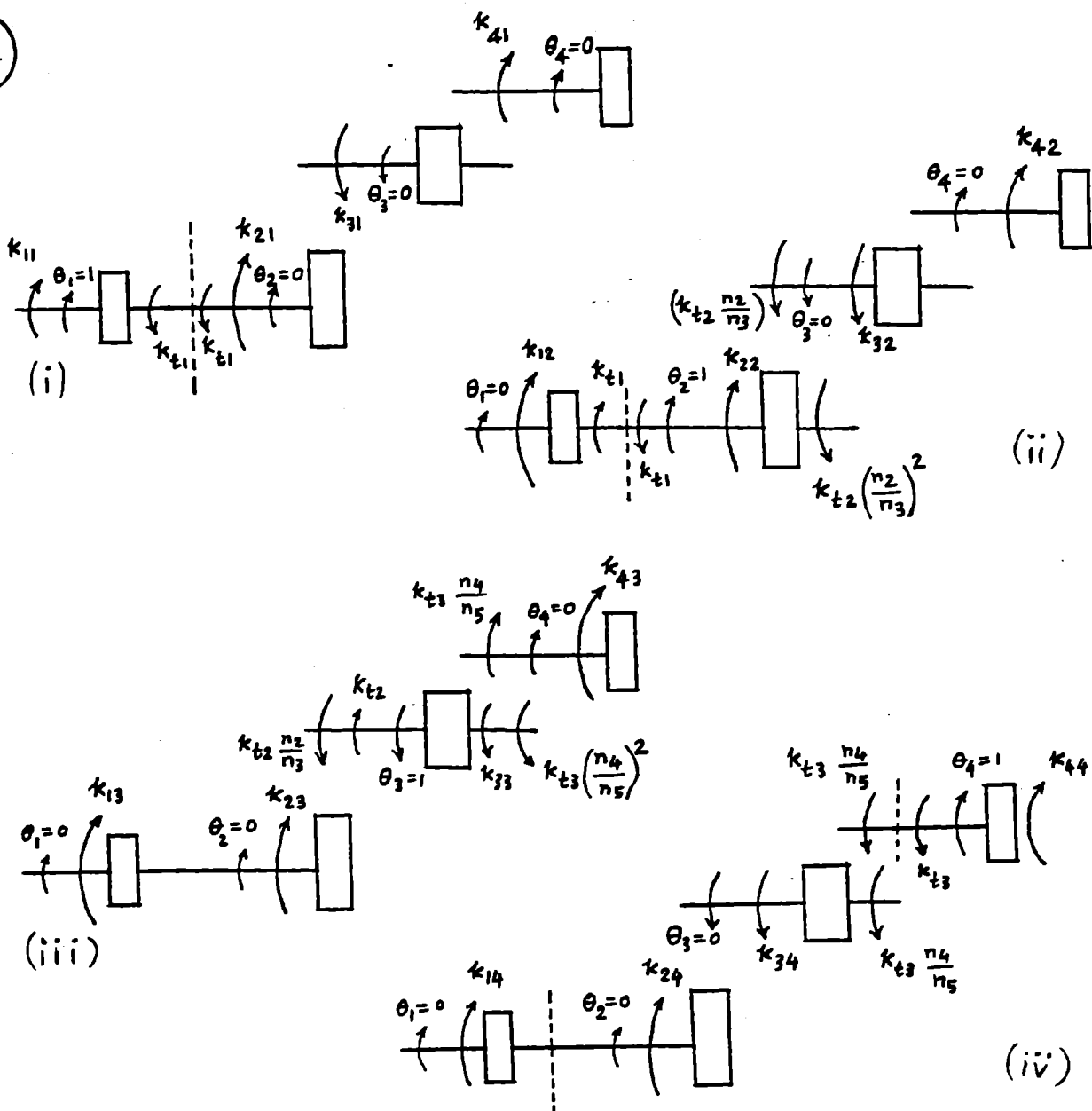

(i) Set $\theta_1 = 1, \theta_2 = \theta_3 = \theta_4 = 0$:

Equilibrium equations give:

$$k_{11} = k_{t1}, \quad k_{21} = -k_{t1}, \quad k_{31} = k_{41} = 0$$

(ii) Set $\theta_2 = 1, \theta_1 = \theta_3 = \theta_4 = 0$:

Equilibrium equations yield:

$$k_{12} = -k_{t1}, \quad k_{22} = k_{t1} + k_{t2} \left(\frac{n_2}{n_3} \right)^2, \quad k_{32} = -k_{t2} \left(\frac{n_2}{n_3} \right), \quad k_{42} = 0$$

(iii) Set $\theta_3 = 1, \theta_1 = \theta_2 = \theta_4 = 0$:

Equilibrium equations provide:

$$k_{13} = 0, \quad k_{23} = -k_{t2} \left(\frac{n_2}{n_3} \right), \quad k_{33} = k_{t2} + k_{t3} \left(\frac{n_4}{n_5} \right)^2, \quad k_{43} = -k_{t3} \left(\frac{n_4}{n_5} \right)$$

(iv) Set $\theta_4 = 1, \theta_1 = \theta_2 = \theta_3 = 0$:

Equilibrium equations give:

$$k_{14} = k_{24} = 0, \quad k_{34} = -k_{t3} \left(\frac{n_4}{n_5} \right), \quad k_{44} = k_{t3}$$

Thus the stiffness matrix is:

$$[k] = \begin{bmatrix} k_{t1} & -k_{t1} & 0 & 0 \\ -k_{t1} & k_{t1} + k_{t2} \left(\frac{n_2}{n_3} \right)^2 & -k_{t2} \left(\frac{n_2}{n_3} \right) & 0 \\ 0 & -k_{t2} \left(\frac{n_2}{n_3} \right) & k_{t2} + k_{t3} \left(\frac{n_4}{n_5} \right)^2 & -k_{t3} \left(\frac{n_4}{n_5} \right) \\ 0 & 0 & -k_{t3} \left(\frac{n_4}{n_5} \right) & k_{t3} \end{bmatrix}$$

6.12

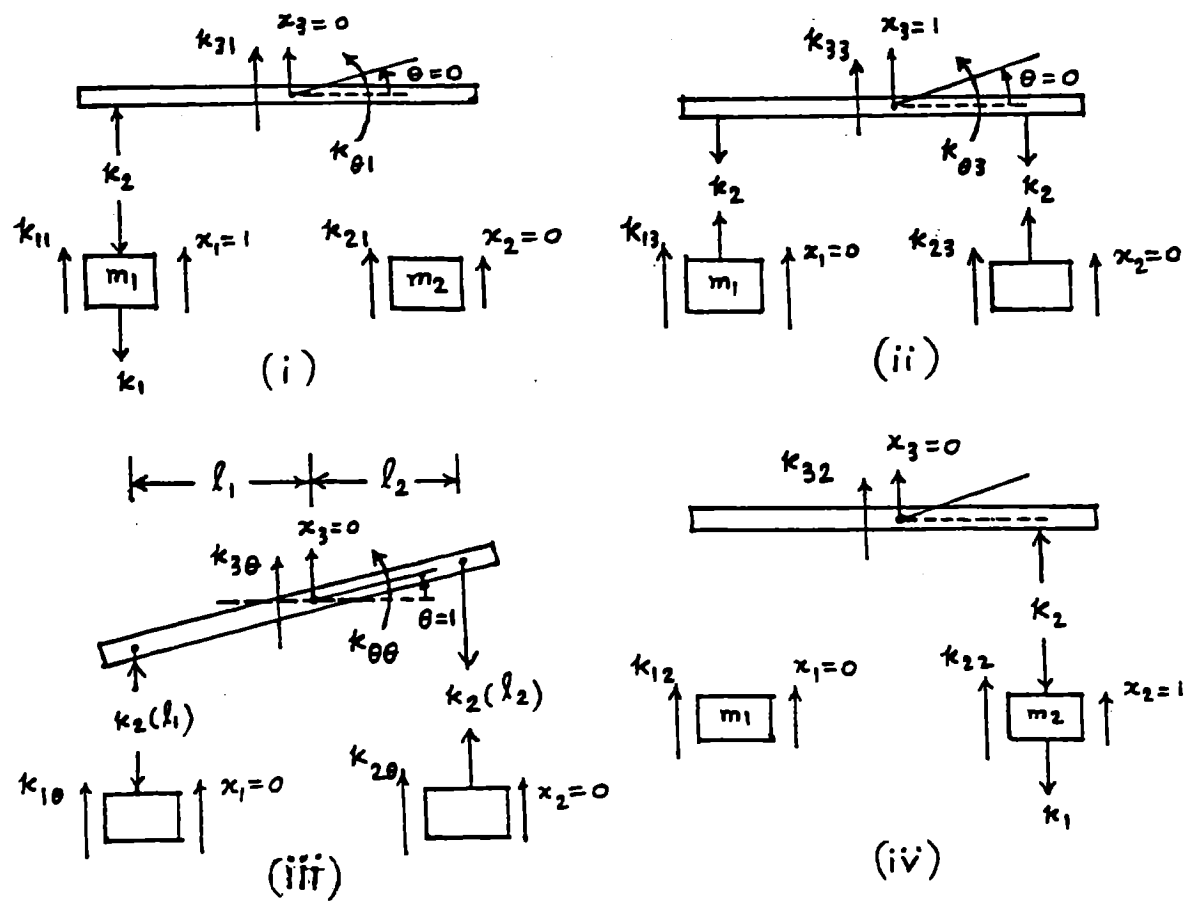

(i) Set $x_1 = 1, x_2 = x_3 = \theta = 0$:

Equilibrium equations:

$$k_{11} = k_1 + k_2, \quad k_{31} = -k_2, \quad k_{\theta 1} = k_2 \ell_1, \quad k_{21} = 0$$

(ii) Set $x_3 = 1, x_1 = x_2 = \theta = 0$:

Equilibrium equations:

$$k_{33} = 2k_2, \quad k_{13} = -k_2, \quad k_{23} = -k_2, \quad k_{\theta 3} = -k_2 \ell_1 + k_2 \ell_2$$

(iii) Set $\theta = 1, x_1 = x_2 = x_3 = 0$:

Equilibrium equations:

$$k_{\theta\theta} = k_2 (\ell_1^2 + \ell_2^2), \quad k_{\theta 3} = k_2 (\ell_2 - \ell_1), \quad k_{1\theta} = k_2 \ell_1, \quad k_{2\theta} = -k_2 \ell_2$$

(iv) Set $x_2 = 1, x_1 = x_3 = \theta = 0$:

Equilibrium equations:

$$k_{12} = 0, \quad k_{32} = -k_2, \quad k_{\theta 2} = -k_2 \ell_2, \quad k_{22} = k_1 + k_2$$

$$\therefore [k] = \begin{bmatrix} (k_1 + k_2) & 0 & -k_2 & k_2 \ell_1 \\ 0 & (k_1 + k_2) & -k_2 & -k_2 \ell_2 \\ -k_2 & -k_2 & 2k_2 & k_2 (\ell_2 - \ell_1) \\ k_2 \ell_1 & -k_2 \ell_2 & k_2 (\ell_2 - \ell_1) & k_2 (\ell_1^2 + \ell_2^2) \end{bmatrix}$$

6.13

(i) Give $F_x = 1, M_\theta = 0$:

Same force of $F_x = 1$ is induced everywhere along the rope. Since k_1 and k_2 are in series,

$$\frac{1}{k_{eq}} = \frac{1}{k_1} + \frac{1}{k_2}$$

$$a_{xx} = \frac{\text{force}}{k_{eq}} = \text{deflection at } m \text{ due } F_x \text{ of } 1 = \frac{k_1 + k_2}{k_1 k_2}$$

Linear deflection of k_1 under $F_x = 1$ is $\frac{1}{k_1}$, angular deflection θ due to linear displacement of $\frac{1}{k_1} = a_{\theta x}$.

$$a_{\theta x} = \text{linear deflection of } k_1 = a_{\theta x} r = \frac{1}{k_1} ; \quad a_{\theta x} = \frac{1}{k_1 r}$$

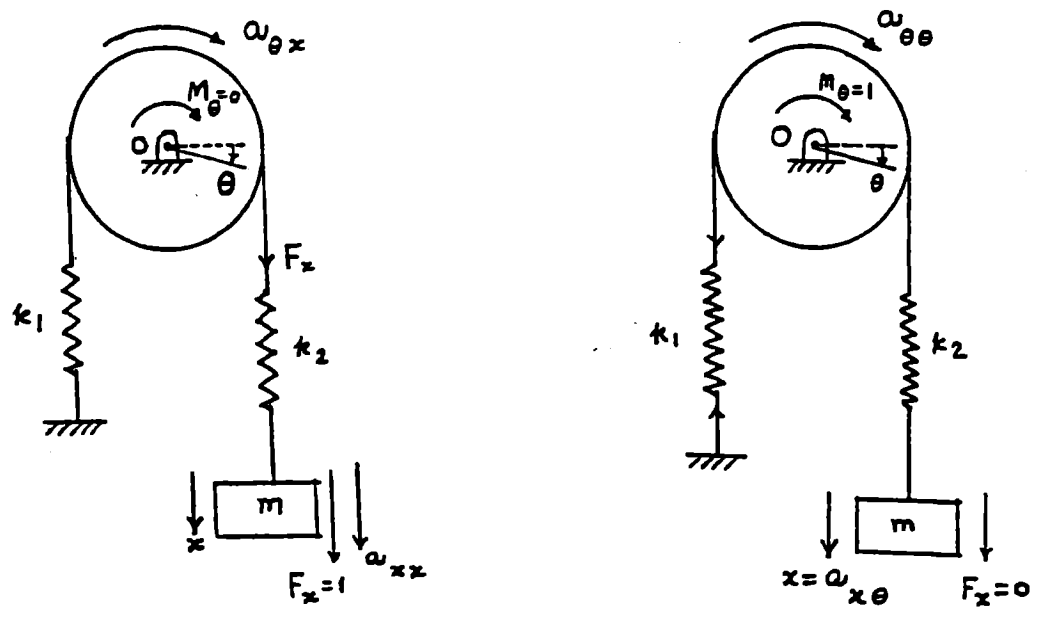

(ii) Give $M_\theta = 1, F_x = 0$:

Extension of $k_1 = a_{\theta\theta} r$, spring force = $k_1 (a_{\theta\theta} r)$.

$$\sum M_\theta = 0 \text{ or } M_\theta = (k_1 a_{\theta\theta} r) r = 1 \text{ or } a_{\theta\theta} = \frac{1}{k_1 r^2}$$

Displacement of $m = a_{x\theta} = a_{\theta\theta} r = \frac{1}{k_1 r}$

$$\therefore [a] = \begin{bmatrix} \frac{k_1 + k_2}{k_1 k_2} & \frac{1}{k_1 r} \\ \frac{1}{k_1 r} & \frac{1}{k_1 r^2} \end{bmatrix}$$

6.14

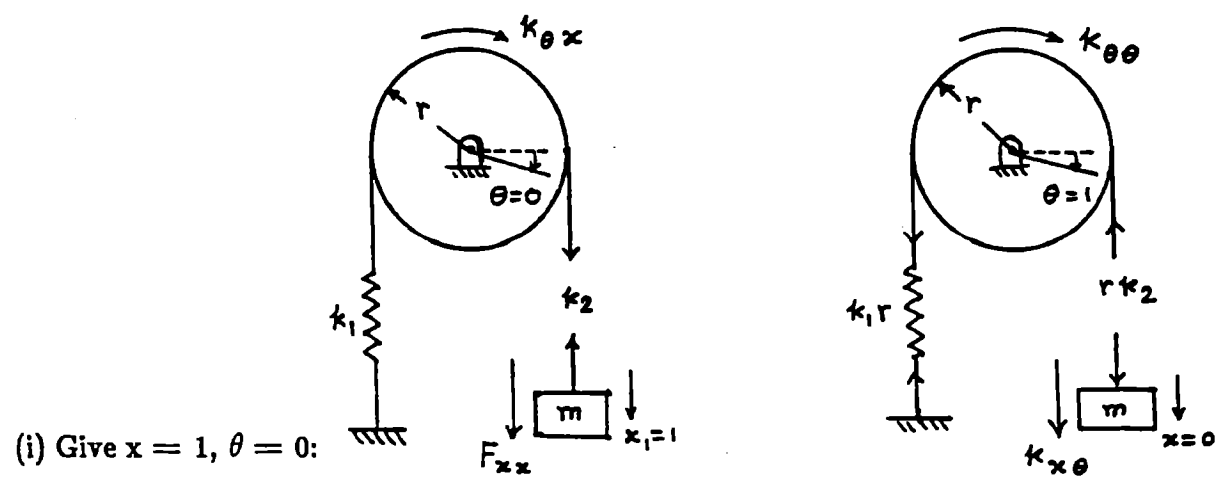

(i) Give $x = 1, \theta = 0$:

Equilibrium equations give:

$$k_{xx} - k_2 = 0 \text{ or } k_{xx} = k_2 ; k_{\theta x} + k_2 r = 0 \text{ or } k_{\theta x} = -k_2 r$$

(ii) Give $\theta = 1, x = 0$:

Equilibrium equations yield:

$$k_{x\theta} + r k_2 = 0 \text{ or } k_{x\theta} = -k_2 r$$

$$k_{\theta\theta} - r^2 k_2 - r^2 k_1 = 0 \text{ or } k_{\theta\theta} = r^2 (k_1 + k_2)$$

$$\therefore [k] = \begin{bmatrix} k_2 & -k_2 r \\ -k_2 r & (k_1 + k_2) r^2 \end{bmatrix}$$

6.15

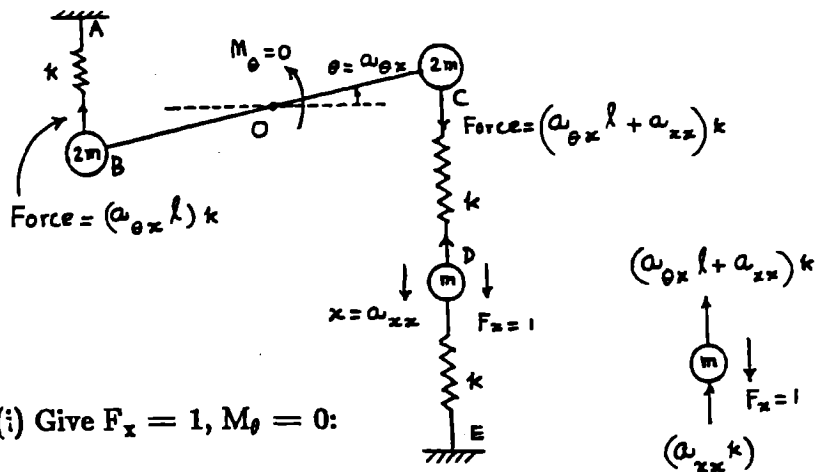

(i) Give $F_x = 1, M_\theta = 0$:

Extension of spring AB = $a_{\theta x} \ell$.

Total extension of spring CD = $(a_{\theta x} \ell + a_{xx})$.

Compression of spring DE = a_{xx} .

$$\sum F = 0 \text{ or } a_{xx} k + a_{\theta x} \ell k + a_{xx} k = 1 \text{ or } 2 a_{xx} k + a_{\theta x} k \ell = 1 \quad (1)$$

$$\sum M_\theta = 0 \text{ or } a_{\theta x} k \ell + (a_{\theta x} k \ell + a_{xx} k) = 0 \text{ or } 2 a_{\theta x} k \ell + a_{xx} k = 0$$

Solution of Eqs. (1) and (2):

$$a_{xx} = \frac{2}{3k} ; a_{\theta x} = -\frac{1}{3k\ell}$$

(ii) Give $M_\theta = 1, F_x = 0$:

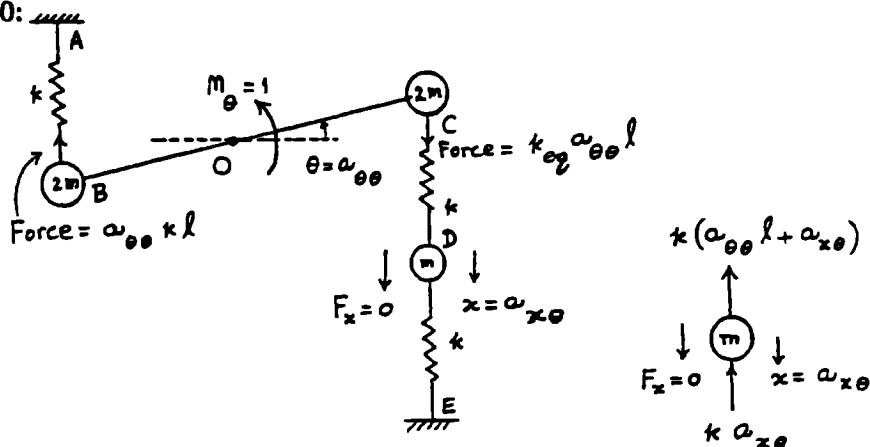

Extension of spring AB = $a_{\theta\theta} \ell$.

Total extension of springs CD and DE = $a_{\theta\theta} \ell$.

k_{eq} of series springs CD and DE = $\frac{k}{2}$.

$$\sum M_0 = 0 \text{ or } (a_{\theta\theta} k \ell) \ell + (k_{eq} a_{\theta\theta} \ell) \ell = 1 \text{ or } a_{\theta\theta} = \frac{2}{3 k \ell^2} \quad (3)$$

$$\sum F = 0 \text{ or } k a_{x\theta} + k a_{\theta\theta} \ell + k a_{x\theta} = 0 \text{ or } a_{x\theta} = -\frac{1}{3 k \ell} \quad (4)$$

$$\therefore [a] = \begin{bmatrix} \frac{2}{3 k} & -\frac{1}{3 k \ell} \\ -\frac{1}{3 k \ell} & \frac{2}{3 k \ell^2} \end{bmatrix}$$

6.16

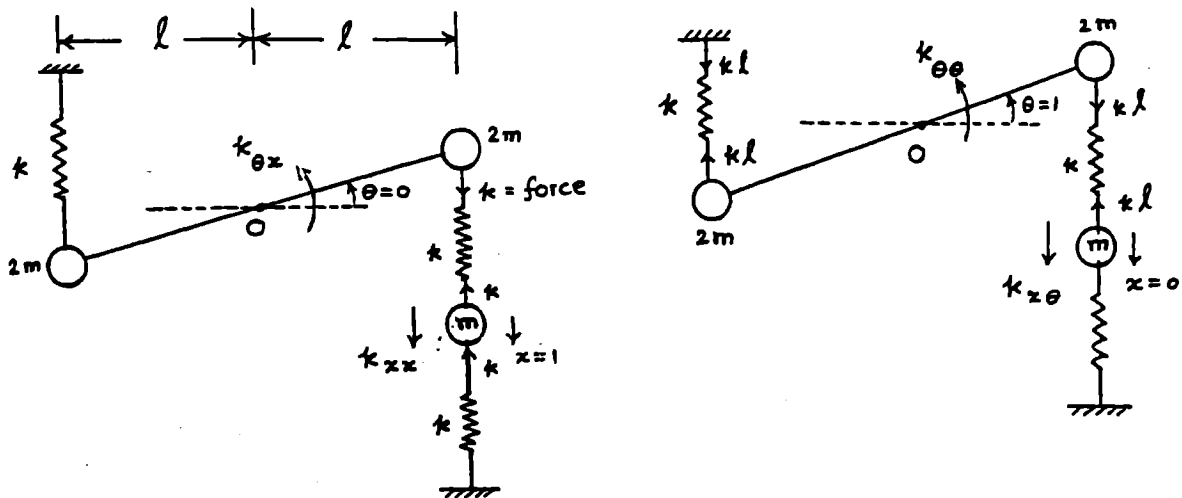

(i) Give $x = 1, \theta = 0$:

$$\sum F = 0 \text{ or } k_{xx} - k - k = 0 \text{ or } k_{xx} = 2k$$

$$\sum M_0 = 0 \text{ or } k_{\theta x} - k \ell = 0 \text{ or } k_{\theta x} = k \ell$$

(ii) Give $\theta = 1, x = 0$:

$$\sum F = 0 \text{ or } k_{x\theta} - k \ell = 0 \text{ or } k_{x\theta} = k \ell$$

$$\sum M_0 = 0 \text{ or } k_{\theta\theta} - k \ell (\ell) - k \ell (\ell) = 0 \text{ or } k_{\theta\theta} = 2k \ell^2$$

$$\therefore [k] = \begin{bmatrix} 2k & k \ell \\ k \ell & 2k \ell^2 \end{bmatrix}$$

6.17

Kinetic energy of the system can be expressed as:

$$T = \frac{1}{2} (2m) (\ell \dot{\theta})^2 + \frac{1}{2} (2m) (\ell \dot{\theta})^2 + \frac{1}{2} m \dot{x}^2 = \frac{1}{2} (4m) (\ell \dot{\theta})^2 + \frac{1}{2} m \dot{x}^2$$

which can be expressed in matrix form as

$$T = \frac{1}{2} (\dot{x} \quad \dot{\theta}) [m] \begin{Bmatrix} \dot{x} \\ \dot{\theta} \end{Bmatrix} \quad \text{where } [m] = \begin{bmatrix} m & 0 \\ 0 & 4 m \ell^2 \end{bmatrix}$$

6.18

Flexibility influence coefficients:

Spring constants of different sections of the shaft (k_i) are

$$k_i = \frac{(GJ)_i}{l_i}; \quad i=1,2,3,4$$

where $(GJ)_i$ = torsional rigidity, J_i = polar moment of inertia, and l_i = length of section i of shaft.

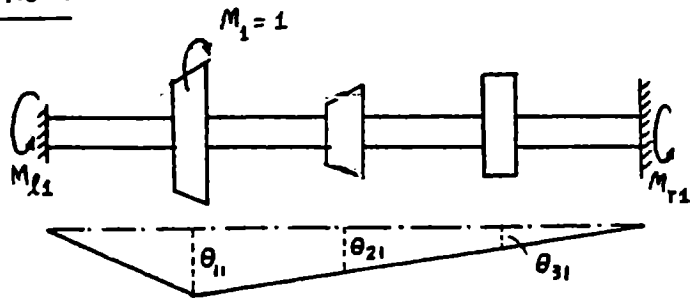

Fig. (A)

Consider disc 1. shaft to the left of disc 1 has a spring constant of k_1 while the shaft to the right side of disc 1 has an equivalent spring constant of

$$k_{e1} = \frac{1}{\sum_{i=2}^4 \left(\frac{1}{k_i} \right)}$$

If we apply unit torque to disc 1 ($M_1 = 1$) as shown in Fig. (A), reactive torques at left and right ends of the shaft are

$$M_{r1} = k_{e1} \theta_{11}, \quad M_{l1} = k_1 \theta_{11}$$

Since $M_{l1} + M_{r1} = M_1 = 1$, we get

$$\theta_{11} = \omega_{11} = \left\{ \sum_{i=2}^4 \left(\frac{1}{k_i} \right) \right\} / \left\{ k_1 \cdot \sum_{i=1}^4 \left(\frac{1}{k_i} \right) \right\}$$

$$M_{l1} = k_1 \theta_{11} = \frac{\sum_{i=2}^4 \left(\frac{1}{k_i} \right)}{\left\{ \sum_{i=1}^4 \left(\frac{1}{k_i} \right) \right\}}; \quad M_{r1} = \frac{\theta_{11}}{\sum_{i=2}^4 \left(\frac{1}{k_i} \right)} = \frac{1}{k_1 \cdot \sum_{i=1}^4 \left(\frac{1}{k_i} \right)}$$

Also,

$$\theta_{31} = \omega_{31} = \frac{M_{r1}}{k_4} = \frac{1}{k_1 k_4 \left\{ \sum_{i=1}^4 \left(\frac{1}{k_i} \right) \right\}}$$

$$\theta_{21} = \omega_{21} = \frac{M_{r1}}{\left\{ \sum_{i=3}^4 \left(\frac{1}{k_i} \right) \right\}} = \frac{1}{k_1 \cdot \left\{ \sum_{i=3}^4 \left(\frac{1}{k_i} \right) \right\} \cdot \left\{ \sum_{i=1}^4 \left(\frac{1}{k_i} \right) \right\}}$$

Consider disc 2. Shaft to the left side of disc 2 has an equivalent spring constant of k_{e2} and the shaft to its right side has an

equivalent spring constant of k_{e3} with

$$k_{e2} = \frac{1}{\sum_{i=1}^2 \left(\frac{1}{k_i}\right)}, \quad k_{e3} = \frac{1}{\sum_{i=3}^4 \left(\frac{1}{k_i}\right)}$$

If we apply a unit torque to disc 2 ($M_2 = 1$), reactive torques at the left and right ends of shaft are

$$M_{l2} = \theta_{22} k_{e2}, \quad M_{r2} = \theta_{22} k_{e3} \quad \text{with} \quad M_2 = M_{l2} + M_{r2} = 1$$

$$\text{Hence} \quad \theta_{22} = a_{22} = \left\{ \sum_{i=1}^2 \left(\frac{1}{k_i}\right) \right\} \cdot \left\{ \sum_{i=3}^4 \left(\frac{1}{k_i}\right) \right\} / \left\{ \sum_{i=1}^4 \left(\frac{1}{k_i}\right) \right\}$$

$$\theta_{32} = a_{32} = \frac{M_{r2}}{k_4} = \frac{\theta_{22}}{k_{e3} \cdot k_4} = \left\{ \sum_{i=1}^2 \left(\frac{1}{k_i}\right) \right\} / \left[k_4 \left\{ \sum_{i=1}^4 \left(\frac{1}{k_i}\right) \right\} \right]$$

$$\theta_{12} = a_{12} = \frac{M_{l2}}{k_1} = \frac{\theta_{22}}{k_{e2} \cdot k_1} = \left\{ \sum_{i=3}^4 \left(\frac{1}{k_i}\right) \right\} / \left[k_1 \left\{ \sum_{i=1}^4 \left(\frac{1}{k_i}\right) \right\} \right]$$

Consider disc 3. Apply unit torque to disc 3 ($M_3 = 1$) to obtain

$$M_{l3} = k_{e4} \theta_{33}, \quad M_{r3} = k_4 \theta_{33}, \quad M_{r3} + M_{l3} = M_3 = 1$$

$$\text{where} \quad k_{e4} = \frac{1}{\sum_{i=1}^3 \left(\frac{1}{k_i}\right)}$$

$$\text{Hence} \quad \theta_{33} = a_{33} = \left\{ \sum_{i=1}^3 \left(\frac{1}{k_i}\right) \right\} / \left[k_4 \cdot \left\{ \sum_{i=1}^4 \left(\frac{1}{k_i}\right) \right\} \right]$$

$$\theta_{13} = a_{13} = \frac{M_{l3}}{k_1} = \frac{1}{k_1 k_4 \left\{ \sum_{i=1}^4 \left(\frac{1}{k_i}\right) \right\}}$$

$$\theta_{23} = a_{23} = \frac{M_{l3}}{\sum_{i=1}^2 \left(\frac{1}{k_i}\right)} = \frac{1}{k_4 \left\{ \sum_{i=1}^3 \left(\frac{1}{k_i}\right) \right\} \left\{ \sum_{i=1}^4 \left(\frac{1}{k_i}\right) \right\}}$$

$$\text{Flexibility matrix is} \quad [a] = \begin{bmatrix} a_{11} & a_{12} & a_{13} \\ a_{21} & a_{22} & a_{23} \\ a_{31} & a_{32} & a_{33} \end{bmatrix}$$

Note: In this problem, it is much easier to derive the stiffness influence coefficients, k_{ij} , compared to a_{ij} . Hence it is advisable to find $[k]$ first and then find $[a]$ by inverting the matrix $[k]$.

Stiffness influence coefficients:

Let angular displacement of disc 1 be unity ($\theta_1 = 1$) and of discs 2 and 3 be zero as shown in Fig. (B). If the torque applied to disc 1 is M_{11} and the reactions are M_{l1} and M_{r1} , we have

$$M_{12} = k_1 \theta_{11} = k_1, \quad M_{21} = k_2 \theta_{11} = k_2$$

$$M_{11} = M_{12} + M_{21} = k_{11} = k_1 + k_2$$

$$k_{21} = -M_{21} = -k_2 \quad (\because \text{reactive torque is opposite to } M_{11} \text{ in direction})$$

$$k_{31} = M_{31} = 0 \quad (\because \text{disc 2 is fixed, no reactive torque is felt at disc 3})$$

Let displacement of disc 2 = 1 and displacements of discs 1 and 3 be zero.

$$k_{22} = k_2 + k_3, \quad k_{12} = -k_2, \quad k_{32} = -k_3$$

Similarly we can obtain

$$k_{33} = k_3 + k_4, \quad k_{13} = 0, \quad k_{23} = -k_3$$

stiffness matrix is $[k] = \begin{bmatrix} k_{11} & k_{12} & k_{13} \\ k_{21} & k_{22} & k_{23} \\ k_{31} & k_{32} & k_{33} \end{bmatrix}$

Equations of motion of the system:

$$[m] \ddot{\vec{\theta}} + [k] \vec{\theta} = \vec{M}_t$$

where $[m] = \begin{bmatrix} J_{d1} & 0 & 0 \\ 0 & J_{d2} & 0 \\ 0 & 0 & J_{d3} \end{bmatrix}$ = matrix of mass moments of inertia of the discs

$$\vec{\theta} = \begin{Bmatrix} \theta_1(t) \\ \theta_2(t) \\ \theta_3(t) \end{Bmatrix} \quad \text{and} \quad \vec{M}_t = \begin{Bmatrix} M_{t1}(t) \\ M_{t2}(t) \\ M_{t3}(t) \end{Bmatrix} = \begin{matrix} \text{vector of} \\ \text{external} \\ \text{torques} \\ \text{applied to discs} \end{matrix} = \begin{Bmatrix} 0 \\ 0 \\ 0 \end{Bmatrix}$$

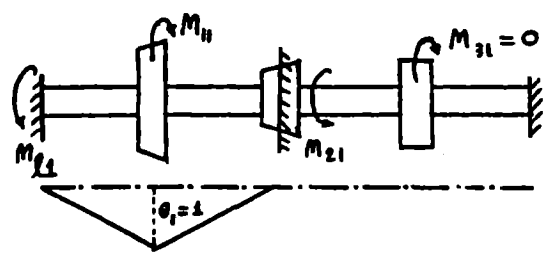

Fig. (B)

6.19 Stiffness influence coefficients:

Let $x_1 = 1, x_2 = x_3 = 0$.

Forces required at 1, 2, 3 are

$$F_1 = k_1 + k_2 = k_{11}; \quad F_2 = -k_2 = k_{21}; \quad F_3 = 0 = k_{31}$$

Let $x_2 = 1, x_1 = x_3 = 0$.

Forces required at 1, 2, 3 are

$$F_1 = -k_2 = k_{12}; \quad F_2 = k_2 + k_3 = k_{22}; \quad F_3 = -k_3 = k_{32}$$

Let $x_3 = 1, x_1 = x_2 = 0$.

Forces required at 1, 2, 3 are

$$F_1 = 0 = k_{13}; \quad F_2 = -k_3 = k_{23}; \quad F_3 = k_3 + k_4 = k_{33}$$

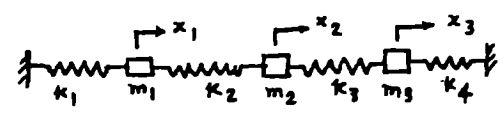

$$\therefore [k] = \begin{bmatrix} (k_1 + k_2) & -k_2 & 0 \\ -k_2 & (k_2 + k_3) & -k_3 \\ 0 & -k_3 & (k_3 + k_4) \end{bmatrix}$$

Flexibility influence coefficients:

Procedure and results are similar to those of problem 6.1.

Equations of motion: $[m] \ddot{\vec{x}} + [k] \vec{x} = \vec{F}$

6.20

From strength of materials, the deflection of the cantilever beam shown is given by

$$w(x) \Big|_{in AB} = \frac{F x^2}{6EI} (-x + 3a) \quad \dots (E_1)$$

$$w(x) \Big|_{in BC} = \frac{F a^2}{6EI} (-a + 3x) \quad \dots (E_2)$$

Apply $F_1 = 1, F_2 = F_3 = 0$: $a_{11} = (F = 1, x = l, a = l \text{ in } (E_1)) = l^3 / (3EI)$

$$a_{21} = (F = 1, x = 2l, a = l \text{ in } (E_2)) = 5l^3 / (6EI)$$

$$a_{31} = (F = 1, x = 3l, a = l \text{ in } (E_2)) = 4l^3 / (3EI)$$

Similarly apply $F_2 = 1, F_1 = F_3 = 0$ to get a_{22}, a_{32}, a_{12} and $F_3 = 1, F_1 = F_2 = 0$ to get a_{33}, a_{13}, a_{23} . Result is

$$[a] = \frac{l^3}{EI} \begin{bmatrix} 1/3 & 5/6 & 4/3 \\ 5/6 & 8/3 & 14/3 \\ 4/3 & 14/3 & 9 \end{bmatrix}$$

Equations of motion:

$$[m] \ddot{\vec{w}} + [k] \vec{w} = \vec{0} \quad \text{or} \quad [a][m] \ddot{\vec{w}} + \vec{w} = \vec{0}$$

with $[m] = \begin{bmatrix} m_1 & 0 & 0 \\ 0 & m_2 & 0 \\ 0 & 0 & m_3 \end{bmatrix}$ and $\vec{w} = \begin{Bmatrix} w_1 \\ w_2 \\ w_3 \end{Bmatrix}$.

6.21

Deflection of a fixed-fixed beam is

$$y(x) \Big|_{in AB} = \frac{F b^2 x^2}{6EIL^3} \{-x(3a+b) + 3aL\} \quad \dots (E_1)$$

$$y(x) \Big|_{in BC} = \frac{F a^2 (L-x)^2}{6EIL^3} \{-(L-x)(3b+a) + 3bL\} \quad \dots (E_2)$$

Apply $F_1 = 1, F_2 = F_3 = 0$:

$$a_{11} = (F = 1, a = l, b = 3l, x = l, L = 4l \text{ in } (E_1)) = 9l^3 / (64EI)$$

$$a_{21} = (F = 1, a = l, b = 3l, x = 2l, L = 4l \text{ in } (E_2)) = l^3 / (6EI)$$

$$a_{31} = (F = 1, a = l, b = 3l, x = 3l, L = 4l \text{ in } (E_2)) = 13l^3 / (192EI)$$

Similarly apply $F_2 = 1, F_1 = F_3 = 0$ to get a_{22}, a_{32}, a_{12} and

$F_3 = 1, F_1 = F_2 = 0$ to get a_{33}, a_{13}, a_{23} . Result is

$$[a] = \frac{l^3}{EI} \begin{bmatrix} 9/64 & 1/6 & 13/192 \\ 1/6 & 1/3 & 1/6 \\ 13/192 & 1/6 & 9/64 \end{bmatrix}$$

6.22

Flexibility matrix:

a_{11} = deflection of m_1 for a unit load on $m_1 = 1/k_1$
 m_2 and m_3 get same displacement (as rigid body motion) as there are no other forces or constraints.

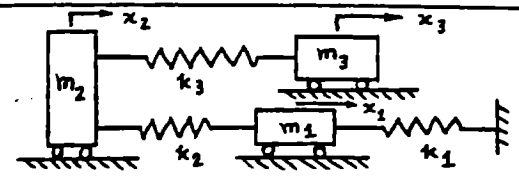

$a_{21} = a_{31} = \frac{1}{k_1}$. If we apply unit load to m_2 , equivalent stiffness is given by $\frac{1}{k_{eq}} = \frac{1}{k_1} + \frac{1}{k_2}$. $a_{22} = \frac{1}{k_{eq}} = \frac{k_1 + k_2}{k_1 k_2}$.

Mass m_3 follows deflection of m_2 . $a_{32} = a_{22}$.
 If we apply unit load to m_3 , equivalent stiffness of springs is given by $\frac{1}{k_{eq}} = \frac{1}{k_3} + \frac{1}{k_1} + \frac{1}{k_2}$. $a_{33} = \frac{1}{k_{eq}} = \frac{1}{k_1} + \frac{1}{k_2} + \frac{1}{k_3}$.

Stiffness matrix:

Let $x_1 = 1, x_2 = x_3 = 0$. Forces required at 1, 2, 3 are

$$F_1 = k_1 + k_2 = k_{11}, F_2 = -k_2 = k_{21}, F_3 = 0 = k_{31}$$

Let $x_2 = 1, x_1 = x_3 = 0$. Forces required at 1, 2, 3 are

$$F_1 = -k_2 = k_{12}, F_2 = k_2 + k_3 = k_{22}, F_3 = -k_3 = k_{23}$$

Let $x_3 = 1, x_1 = x_2 = 0$. Forces required at 1, 2, 3 are

$$F_1 = 0 = k_{13}, F_2 = -k_3 = k_{23}, F_3 = k_3 = k_{33}$$

$$[k] = \begin{bmatrix} (k_1 + k_2) & -k_2 & 0 \\ -k_2 & (k_2 + k_3) & -k_3 \\ 0 & -k_3 & k_3 \end{bmatrix}; [a] = \begin{bmatrix} 1/k_1 & 1/k_1 & 1/k_1 \\ 1/k_1 & (1/k_1 + 1/k_2) & (1/k_1 + 1/k_2) \\ 1/k_1 & (1/k_1 + 1/k_2) & (1/k_1 + 1/k_2 + 1/k_3) \end{bmatrix}$$

6.23

Assume small deflections; hence tension in spring (P) remains constant.

Let $F_1 = 1, F_2 = F_3 = 0$ as shown in Fig. (A).

Vertical force balance gives

$$F_1 = 1 = \left(\frac{a_{11}}{l_1}\right)P + \left(\frac{a_{11}}{l_2 + l_3 + l_4}\right)P$$

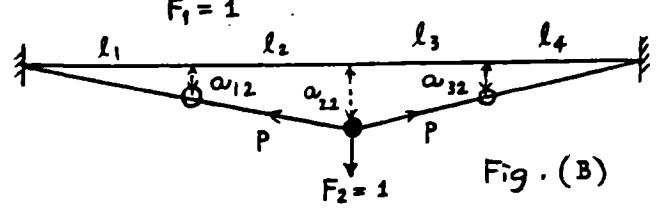
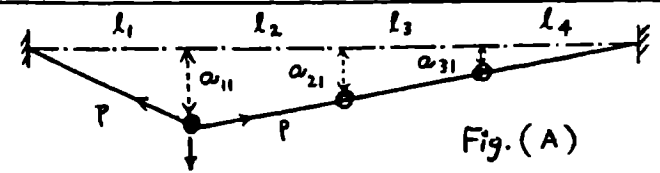

$$a_{11} = \frac{1}{P \left(\frac{1}{l_1} + \frac{1}{l_2 + l_3 + l_4} \right)}$$

From relations of triangles,

$$\frac{a_{11}}{l_2 + l_3 + l_4} = \frac{a_{21}}{l_3 + l_4} \quad \text{and} \quad \frac{a_{11}}{l_2 + l_3 + l_4} = \frac{a_{31}}{l_4}$$

$$a_{21} = \left(\frac{l_3 + l_4}{l_2 + l_3 + l_4} \right) a_{11}, \quad a_{31} = \left(\frac{l_4}{l_2 + l_3 + l_4} \right) a_{11}$$

When $F_2 = 1, F_1 = F_3 = 0$, vertical force balance gives (Fig. (B))

$$F_2 = 1 = \left(\frac{a_{22}}{l_1 + l_2} \right) P + \left(\frac{a_{22}}{l_3 + l_4} \right) P \Rightarrow a_{22} = \frac{1}{P \left\{ \frac{1}{l_1 + l_2} + \frac{1}{l_3 + l_4} \right\}}$$

From triangle relations

$$a_{12} = \left(\frac{l_1}{l_1 + l_2} \right) a_{22}, \quad a_{32} = \left(\frac{l_4}{l_3 + l_4} \right) a_{22}$$

When $F_3 = 1, F_1 = F_2 = 0$ (Fig. (C)), vertical force balance gives

$$F_3 = 1 = \left(\frac{a_{33}}{l_1 + l_2 + l_3} \right) P + \left(\frac{a_{33}}{l_4} \right) P; \quad a_{33} = \frac{1}{P \left(\frac{1}{l_1 + l_2 + l_3} + \frac{1}{l_4} \right)}$$

From triangle relations,

$$a_{23} = \left(\frac{l_1 + l_2}{l_1 + l_2 + l_3} \right) a_{33}, \quad a_{13} = \left(\frac{l_1}{l_1 + l_2 + l_3} \right) a_{33}$$

Equations of motion:

$$[a] [m] \ddot{\vec{w}} + \vec{w} = \vec{0}$$

$$\text{with } [m] = \begin{bmatrix} m_1 & 0 & 0 \\ 0 & m_2 & 0 \\ 0 & 0 & m_3 \end{bmatrix}, \quad \vec{w} = \begin{Bmatrix} w_1 \\ w_2 \\ w_3 \end{Bmatrix}.$$

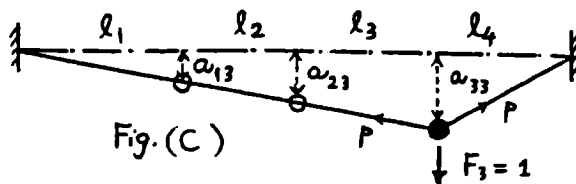

Fig. (C)

6.24

Let x_1, x_2 and x_3 denote the displacements of top, middle and bottom masses. Equations of motion are

$$m \ddot{x}_1 = -k x_1 - k(x_1 - x_2) - 3k(x_1 - x_3)$$

$$2m \ddot{x}_2 = -2k x_2 - k(x_2 - x_1) - k(x_2 - x_3)$$

$$m \ddot{x}_3 = -k x_3 - 3k(x_3 - x_1) - k(x_3 - x_2)$$

$$\text{i.e. } \begin{bmatrix} m & 0 & 0 \\ 0 & 2m & 0 \\ 0 & 0 & m \end{bmatrix} \begin{Bmatrix} \ddot{x}_1 \\ \ddot{x}_2 \\ \ddot{x}_3 \end{Bmatrix} + \begin{bmatrix} 5k & -k & -3k \\ -k & 4k & -k \\ -3k & -k & 5k \end{bmatrix} \begin{Bmatrix} x_1 \\ x_2 \\ x_3 \end{Bmatrix} = \begin{Bmatrix} 0 \\ 0 \\ 0 \end{Bmatrix}$$

6.25

Let o move to o' with δ small.

$$\text{Then } F_1 = k \delta \cos(\theta - 45^\circ)$$

$$F_2 = k \delta \cos(135^\circ - \theta)$$

$$F_3 = k \delta \cos(\theta - 45^\circ)$$

$$F_4 = k \delta \cos(135^\circ - \theta)$$

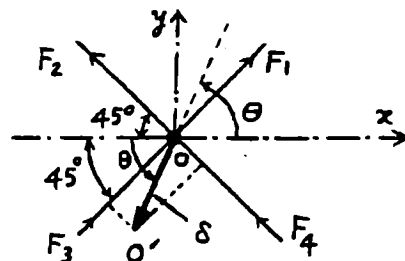

Force along δ is:

$$\begin{aligned} F &= F_1 \cos(\theta - 45^\circ) + F_2 \cos(135^\circ - \theta) + F_3 \cos(\theta - 45^\circ) + F_4 \cos(135^\circ - \theta) \\ &= 2k\delta [\cos^2(\theta - 45^\circ) + \cos^2(135^\circ - \theta)] \\ &= 2k\delta \end{aligned}$$

\therefore Stiffness influence coefficient of junction point in arbitrary direction = $F/\delta = 2k$

6.26

Stiffness matrix is given by Eq. (6.6):

$$[k] = \begin{bmatrix} (k_1 + k_2) & -k_2 & 0 & 0 & \dots & 0 \\ -k_2 & (k_2 + k_3) & -k_3 & 0 & \dots & 0 \\ 0 & -k_3 & (k_3 + k_4) & -k_4 & \dots & 0 \\ \vdots & \vdots & \vdots & \vdots & \ddots & \vdots \\ 0 & 0 & 0 & 0 & \dots & (k_n + k_{n+1}) \end{bmatrix}$$

All elements except those on the three diagonals are zero. Hence $[k]$ is a band matrix. In fact, it is a tri-diagonal matrix.

6.27

We use the expression of kinetic energy to derive the mass matrix. Let the generalized coordinates be x_1 , x_2 and x_3 . The kinetic energy of the system is:

$$T = \frac{1}{2} m_1 \dot{x}_1^2 + \frac{1}{2} m_2 \dot{x}_2^2 + \frac{1}{2} m_3 \dot{x}_3^2$$

This can be expressed in matrix form as

$$T = \frac{1}{2} (\dot{x}_1 \quad \dot{x}_2 \quad \dot{x}_3) [m] \begin{pmatrix} \dot{x}_1 \\ \dot{x}_2 \\ \dot{x}_3 \end{pmatrix}$$

with the mass matrix given by

$$[m] = \begin{bmatrix} m_1 & 0 & 0 \\ 0 & m_2 & 0 \\ 0 & 0 & m_3 \end{bmatrix}$$

6.28

We use the expression of kinetic energy to derive the mass matrix. Using the generalized coordinates θ , x_1 and x_2 , the kinetic energy of the system can be expressed as:

$$T = \frac{1}{2} J_0 \dot{\theta}^2 + \frac{1}{2} (2m) \dot{x}_1^2 + \frac{1}{2} m \dot{x}_2^2$$

where $J_0 = J_G + (2m) \left(\frac{\ell}{2}\right)^2 = \frac{2}{3} m \ell^2$. T can be expressed in matrix form as:

$$T = \frac{1}{2} (\dot{\theta} \quad \dot{x}_1 \quad \dot{x}_2) [m] \begin{Bmatrix} \dot{\theta} \\ \dot{x}_1 \\ \dot{x}_2 \end{Bmatrix} \quad \text{with the mass matrix} \quad [m] = \begin{bmatrix} \frac{2}{3} m \ell^2 & 0 & 0 \\ 0 & 2 m & 0 \\ 0 & 0 & m \end{bmatrix}$$

6.29

We derive the mass matrix from the kinetic energy expression. Using the coordinates x_1 , x_2 and x_3 , the kinetic energy of the system can be expressed as (see figure in the solution of Problem 6.3):

$$T = \frac{1}{2} J_G \dot{\theta}^2 + \frac{1}{2} (2m) \dot{x}_G^2 + \frac{1}{2} (5m) \dot{x}_2^2 \quad (1)$$

$$\text{Using } J_G = \frac{1}{12} (2m) (5\ell)^2 = \frac{25}{6} m \ell^2 \quad (2)$$

$$x_G = \frac{x_1 + x_3}{2}, \quad \theta = \frac{x_1 - x_3}{5\ell} \quad (3)$$

Eq. (1) can be rewritten as:

$$\begin{aligned} T &= \frac{1}{2} \left(\frac{25}{6} m \ell^2 \right) \left(\frac{\dot{x}_1 - \dot{x}_3}{5\ell} \right)^2 + \frac{1}{2} (2m) \left(\frac{\dot{x}_1 + \dot{x}_3}{2} \right)^2 + \frac{1}{2} (5m) \dot{x}_2^2 \\ &= \frac{1}{2} \frac{2m}{3} \dot{x}_1^2 + \frac{1}{2} \frac{2m}{3} \dot{x}_3^2 + \frac{1}{2} \frac{1}{3} m (2\dot{x}_1 \dot{x}_3) + \frac{1}{2} (5m) \dot{x}_2^2 \end{aligned} \quad (4)$$

Equation (4) can be expressed in matrix form as

$$T = \frac{1}{2} (\dot{x}_1 \quad \dot{x}_2 \quad \dot{x}_3) [m] \begin{Bmatrix} \dot{x}_1 \\ \dot{x}_2 \\ \dot{x}_3 \end{Bmatrix} \quad \text{with the mass matrix} \quad [m] = m \begin{bmatrix} \frac{2}{3} & 0 & \frac{1}{3} \\ 0 & 5 & 0 \\ \frac{1}{3} & 0 & \frac{2}{3} \end{bmatrix}$$

6.30

The kinetic energy of the system can be expressed, in terms of the coordinates x_1 , x_2 and x_3 as:

$$T = \frac{1}{2} M \dot{x}_1^2 + \frac{1}{2} J_0 \dot{\theta}^2 + \frac{1}{2} (3m) \dot{x}_2^2 + \frac{1}{2} m \dot{x}_3^2 \quad (1)$$

Using the relation $\theta = \frac{x_2 - x_1}{3r}$, Eq. (1) can be rewritten as

$$T = \frac{1}{2} \left(M + \frac{J_0}{9r^2} \right) \dot{x}_1^2 + \frac{1}{2} \left(\frac{J_0}{9r^2} + 3m \right) \dot{x}_2^2 - \frac{1}{2} \frac{J_0}{9r^2} (2\dot{x}_1 \dot{x}_2) + \frac{1}{2} m \dot{x}_3^2 \quad (2)$$

By expressing T in matrix form as

$$T = \frac{1}{2} (\dot{x}_1 \quad \dot{x}_2 \quad \dot{x}_3) [m] \begin{Bmatrix} \dot{x}_1 \\ \dot{x}_2 \\ \dot{x}_3 \end{Bmatrix} \quad \text{the mass matrix} \quad [m] = \begin{bmatrix} \left(M + \frac{J_0}{9 r^2} \right) & -\frac{J_0}{9 r^2} & 0 \\ -\frac{J_0}{9 r^2} & \left(\frac{J_0}{9 r^2} + 3 m \right) & 0 \\ 0 & 0 & m \end{bmatrix}$$

6.31

The kinetic energy of the system can be expressed as

$$T = \frac{1}{2} I_1 \dot{\theta}_1^2 + \frac{1}{2} I_2 \dot{\theta}_2^2 + \frac{1}{2} I_3 \left(\dot{\theta}_2 \frac{n_2}{n_3} \right)^2 + \frac{1}{2} I_4 \dot{\theta}_3^2 + \frac{1}{2} I_5 \left(\dot{\theta}_3 \frac{n_4}{n_5} \right)^2 + \frac{1}{2} I_6 \dot{\theta}_4^2$$

This can be expressed in matrix form as

$$T = \frac{1}{2} (\dot{\theta}_1 \quad \dot{\theta}_2 \quad \dot{\theta}_3 \quad \dot{\theta}_4) [m] \begin{Bmatrix} \dot{\theta}_1 \\ \dot{\theta}_2 \\ \dot{\theta}_3 \\ \dot{\theta}_4 \end{Bmatrix}$$

and the mass matrix can be identified as

$$[m] = \begin{bmatrix} I_1 & 0 & 0 & 0 \\ 0 & \left(I_2 + I_3 \frac{n_2^2}{n_3^2} \right) & 0 & 0 \\ 0 & 0 & \left(I_4 + I_5 \frac{n_4^2}{n_5^2} \right) & 0 \\ 0 & 0 & 0 & I_6 \end{bmatrix}$$

6.32

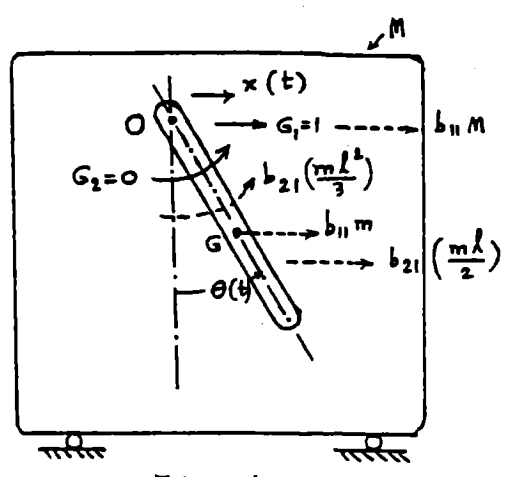

Fig. 1

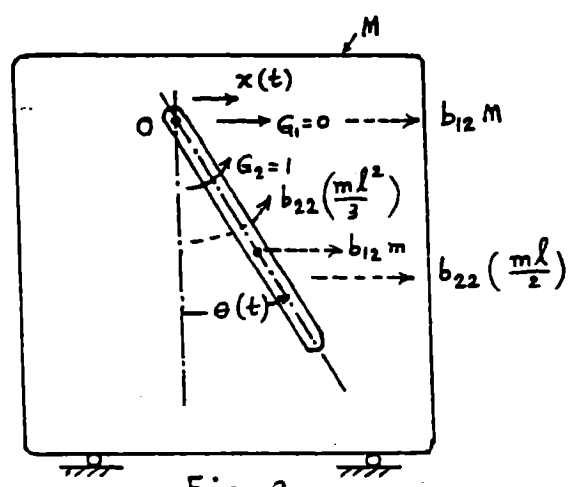

Fig. 2

Let $x(t)$ and $\theta(t)$ indicate the coordinates to define the linear and angular positions of the trailer (M) and the pendulum (m), respectively. To derive the inverse inertia influence coefficients, first we apply a unit linear impulse at point O (along $x(t)$) and write the impulse-momentum relations as (see Fig. 1):

Linear impulse-momentum relation along x :

$$\dot{x} = 1 = b_{11} (M + m) + b_{21} \left(\frac{m \ell}{2} \right) \quad (1)$$

Angular impulse-momentum relation along θ :

$$\dot{\theta} = 0 = b_{11} \left(\frac{m \ell}{2} \right) + b_{21} \left(\frac{m \ell^2}{3} \right) \quad (2)$$

Solution of Eqs. (1) and (2) gives:

$$b_{11} = \frac{4}{4M + m} ; b_{21} = -\frac{6}{4M\ell + m\ell} \quad (3)$$

Next we apply a unit angular impulse at point O (along $\theta(t)$) and write the impulse-momentum relations as (see Fig. 2):

Linear impulse-momentum relation along x :

$$\dot{x} = 0 = b_{12} (M + m) + b_{22} \left(\frac{m \ell}{2} \right) \quad (4)$$

Angular impulse-momentum about O along θ :

$$\dot{\theta} = 1 = b_{12} \left(\frac{m \ell}{2} \right) + b_{22} \left(\frac{m \ell^2}{3} \right) \quad (5)$$

Solution of Eqs. (4) and (5) gives:

$$b_{12} = -\frac{6}{4M\ell + m\ell} ; b_{22} = \frac{12(M + m)}{4Mm\ell^2 + m^2\ell^2} \quad (6)$$

Thus the inverse mass matrix is given by

$$[b] = [m]^{-1} = \begin{bmatrix} \left(\frac{4}{4M + m} \right) & -\left(\frac{6}{4M\ell + m\ell} \right) \\ -\left(\frac{6}{4M\ell + m\ell} \right) & \left(\frac{12(M + m)}{4Mm\ell^2 + m^2\ell^2} \right) \end{bmatrix} \quad (7)$$

6.33

The shear building can be modeled as shown below:

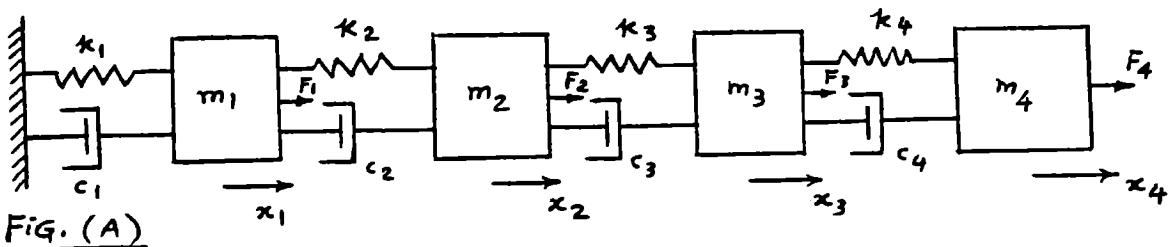

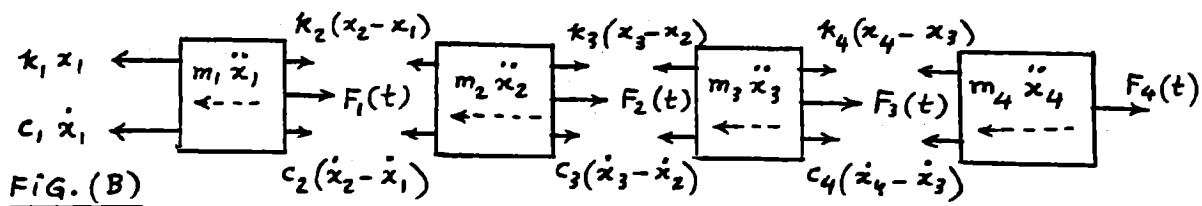

(a) Equations of motion (from free body diagrams in Fig. B):

$$\begin{aligned}
 m_1 \ddot{x}_1 + c_1 \dot{x}_1 + \kappa_1 x_1 - c_2 (\dot{x}_2 - \dot{x}_1) - \kappa_2 (x_2 - x_1) &= F_1(t) \\
 m_2 \ddot{x}_2 + c_2 (\dot{x}_2 - \dot{x}_1) + \kappa_2 (x_2 - x_1) - c_3 (\dot{x}_3 - \dot{x}_2) - \kappa_3 (x_3 - x_2) &= F_2(t) \\
 m_3 \ddot{x}_3 + c_3 (\dot{x}_3 - \dot{x}_2) + \kappa_3 (x_3 - x_2) - c_4 (\dot{x}_4 - \dot{x}_3) - \kappa_4 (x_4 - x_3) &= F_3(t) \\
 m_4 \ddot{x}_4 + c_4 (\dot{x}_4 - \dot{x}_3) + \kappa_4 (x_4 - x_3) &= F_4(t) \quad \text{----- (E1)}
 \end{aligned}$$

(b) Lagrange's equations are

$$\frac{d}{dt} \left(\frac{\partial T}{\partial \dot{\vartheta}_j} \right) - \frac{\partial T}{\partial \vartheta_j} + \frac{\partial V}{\partial \vartheta_j} + \frac{\partial D}{\partial \dot{\vartheta}_j} = Q_j \quad \text{----- (E2)}$$

where T = kinetic energy, V = potential energy, R = Rayleigh's dissipation function, $Q_j = j^{\text{th}}$ generalized force and $\vartheta_j = j^{\text{th}}$ generalized coordinate:

$$\begin{aligned}
 T &= \frac{1}{2} \{ m_1 \dot{x}_1^2 + m_2 \dot{x}_2^2 + m_3 \dot{x}_3^2 + m_4 \dot{x}_4^2 \} \\
 V &= \frac{1}{2} \{ \kappa_1 x_1^2 + \kappa_2 (x_2 - x_1)^2 + \kappa_3 (x_3 - x_2)^2 + \kappa_4 (x_4 - x_3)^2 \} \\
 R &= \frac{1}{2} \{ c_1 \dot{x}_1^2 + c_2 (\dot{x}_2 - \dot{x}_1)^2 + c_3 (\dot{x}_3 - \dot{x}_2)^2 + c_4 (\dot{x}_4 - \dot{x}_3)^2 \} \\
 Q_j &= F_j \quad ; \quad j = 1, 2, 3, 4
 \end{aligned}$$

Using $\vartheta_j = x_j$; $j = 1, 2, 3, 4$, the application of Eqs. (E2) yields the equations of motion given in (E1).

6.34 Coordinates of the bob are $(x + l \cos \theta, l \sin \theta)$

T = kinetic energy = kinetic energy of slider + kinetic energy of bob

$$\begin{aligned}
 &= \frac{1}{2} m \left(\frac{dx}{dt} \right)^2 + \frac{1}{2} m \left[\left\{ \frac{d}{dt} (x + l \cos \theta) \right\}^2 + \left\{ \frac{d}{dt} (l \sin \theta) \right\}^2 \right] \\
 &= \frac{1}{2} m \dot{x}^2 + \frac{1}{2} m \dot{x}^2 + \frac{1}{2} m l^2 \dot{\theta}^2 (\sin^2 \theta + \cos^2 \theta) \\
 &\quad - \frac{1}{2} m (2 \dot{x} l \sin \theta \dot{\theta}) \\
 &= m \dot{x}^2 + \frac{1}{2} m l^2 \dot{\theta}^2 - m \dot{x} \dot{\theta} l \sin \theta \simeq m \dot{x}^2 + \frac{1}{2} m l^2 \dot{\theta}^2 \text{ for small } \theta.
 \end{aligned}$$

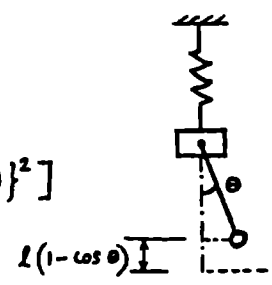

$$V = \text{potential energy} = \text{potential energy of spring} + \text{potential energy of bob}$$

$$= \frac{1}{2} k x^2 + m g l (1 - \cos \theta)$$

(Note: Potential energy of slider need not be considered if $x=0$ corresponds to static equilibrium position)

$$\text{Since } \cos \theta \approx 1 - \frac{1}{2} \theta^2, \quad V = \frac{1}{2} k x^2 + \frac{1}{2} m g l \theta^2$$

As there are no external forces, Lagrange's equations become

$$\frac{d}{dt} \left(\frac{\partial T}{\partial \dot{q}_j} \right) - \frac{\partial T}{\partial q_j} + \frac{\partial V}{\partial q_j} = 0; \quad j = 1, 2$$

Here $q_1 = x$ and $q_2 = \theta$

$$\frac{\partial T}{\partial x} = 0, \quad \frac{\partial T}{\partial \dot{x}} = 2 m \dot{x}, \quad \frac{d}{dt} \left(\frac{\partial T}{\partial \dot{x}} \right) = 2 m \ddot{x}, \quad \frac{\partial V}{\partial x} = k x$$

$$\frac{\partial T}{\partial \theta} = 0, \quad \frac{\partial T}{\partial \dot{\theta}} = m l^2 \dot{\theta}, \quad \frac{d}{dt} \left(\frac{\partial T}{\partial \dot{\theta}} \right) = m l^2 \ddot{\theta}, \quad \frac{\partial V}{\partial \theta} = m g l \theta$$

Lagrange's equations become

$$2 m \ddot{x} + k x = 0; \quad m l^2 \ddot{\theta} + m g l \theta = 0 \quad \text{or} \quad l \ddot{\theta} + g \theta = 0$$

6.35

(1) With x_1 and x_2 as generalized coordinates:

Since $x_1 = x - l_1 \theta$ and $x_2 = x + l_2 \theta$,

$$x = \left(\frac{x_1 l_2 + x_2 l_1}{l_1 + l_2} \right) \quad \text{and} \quad \theta = \left(\frac{x_2 - x_1}{l_1 + l_2} \right)$$

$$T = \frac{1}{2} m \dot{x}^2 + \frac{1}{2} J_0 \dot{\theta}^2 = \frac{1}{2} m \left(\frac{\dot{x}_1 l_2 + \dot{x}_2 l_1}{l_1 + l_2} \right)^2 + \frac{1}{2} J_0 \left(\frac{\dot{x}_2 - \dot{x}_1}{l_1 + l_2} \right)^2$$

$$\frac{\partial T}{\partial x_1} = 0, \quad \frac{\partial T}{\partial \dot{x}_1} = \frac{m}{2(l_1 + l_2)^2} (2 l_2^2 \dot{x}_1 + 2 l_1 l_2 \dot{x}_2) + \frac{J_0}{2(l_1 + l_2)^2} (2 \dot{x}_1 - 2 \dot{x}_2),$$

$$\frac{d}{dt} \left(\frac{\partial T}{\partial \dot{x}_1} \right) = \frac{m}{(l_1 + l_2)^2} (l_2^2 \ddot{x}_1 + l_1 l_2 \ddot{x}_2) + \frac{J_0}{(l_1 + l_2)^2} (\ddot{x}_1 - \ddot{x}_2)$$

$$\frac{\partial T}{\partial x_2} = 0, \quad \frac{\partial T}{\partial \dot{x}_2} = \frac{m}{2(l_1 + l_2)^2} (2 l_1^2 \dot{x}_2 + 2 l_1 l_2 \dot{x}_1) + \frac{J_0}{2(l_1 + l_2)^2} (2 \dot{x}_2 - 2 \dot{x}_1),$$

$$\frac{d}{dt} \left(\frac{\partial T}{\partial \dot{x}_2} \right) = \frac{m}{(l_1 + l_2)^2} (l_1^2 \ddot{x}_2 + l_1 l_2 \ddot{x}_1) + \frac{J_0}{(l_1 + l_2)^2} (\ddot{x}_2 - \ddot{x}_1)$$

$$V = \frac{1}{2} k_1 x_1^2 + \frac{1}{2} k_2 x_2^2$$

$$\frac{\partial V}{\partial x_1} = k_1 x_1, \quad \frac{\partial V}{\partial x_2} = k_2 x_2$$

Lagrange's equations, Eq. (6.41), give

$$\frac{m}{(l_1 + l_2)^2} (l_2^2 \ddot{x}_1 + l_1 l_2 \ddot{x}_2) + \frac{J_0}{(l_1 + l_2)^2} (\ddot{x}_1 - \ddot{x}_2) + k_1 x_1 = 0$$

$$\frac{m}{(l_1+l_2)^2} (l_1^2 \ddot{x}_2 + l_1 l_2 \ddot{x}_1) + \frac{J_0}{(l_1+l_2)^2} (\ddot{x}_2 - \ddot{x}_1) + k_2 x_2 = 0$$

i.e.

$$\ddot{x}_1 (m l_2^2 + J_0) + \ddot{x}_2 (m l_1 l_2 - J_0) + x_1 (l_1+l_2)^2 k_1 = 0$$

$$\ddot{x}_1 (m l_1 l_2 - J_0) + \ddot{x}_2 (m l_1^2 + J_0) + x_2 (l_1+l_2)^2 k_2 = 0$$

(2) With x and θ as generalized coordinates:

$$T = \frac{1}{2} m \dot{x}^2 + \frac{1}{2} J_0 \dot{\theta}^2$$

$$V = \frac{1}{2} k_1 (x - l_1 \theta)^2 + \frac{1}{2} k_2 (x + l_2 \theta)^2$$

$$\frac{\partial T}{\partial x} = 0, \quad \frac{\partial T}{\partial \dot{x}} = m \dot{x}, \quad \frac{d}{dt} \left(\frac{\partial T}{\partial \dot{x}} \right) = m \ddot{x}, \quad \frac{\partial V}{\partial x} = k_1 (x - l_1 \theta) + k_2 (x + l_2 \theta)$$

$$\frac{\partial T}{\partial \theta} = 0, \quad \frac{\partial T}{\partial \dot{\theta}} = J_0 \dot{\theta}, \quad \frac{d}{dt} \left(\frac{\partial T}{\partial \dot{\theta}} \right) = J_0 \ddot{\theta}, \quad \frac{\partial V}{\partial \theta} = -k_1 l_1 (x - l_1 \theta) + k_2 l_2 (x + l_2 \theta)$$

Lagrange's equations give

$$m \ddot{x} + k_1 (x - l_1 \theta) + k_2 (x + l_2 \theta) = 0$$

$$J_0 \ddot{\theta} - k_1 l_1 (x - l_1 \theta) + k_2 l_2 (x + l_2 \theta) = 0$$

6.36

$$T = \frac{1}{2} m_1 \dot{x}_1^2 + \frac{1}{2} m_2 \dot{x}_2^2 + \frac{1}{2} m_3 \dot{x}_3^2$$

$$V = \frac{1}{2} k_1 x_1^2 + \frac{1}{2} k_2 (x_2 - x_1)^2 + \frac{1}{2} k_3 (x_3 - x_2)^2 + \frac{1}{2} k_4 x_3^2$$

$$\frac{\partial T}{\partial x_1} = 0, \quad \frac{\partial T}{\partial \dot{x}_1} = m_1 \dot{x}_1, \quad \frac{d}{dt} \left(\frac{\partial T}{\partial \dot{x}_1} \right) = m_1 \ddot{x}_1, \quad \frac{\partial V}{\partial x_1} = k_1 x_1 - k_2 (x_2 - x_1)$$

$$\frac{\partial T}{\partial x_2} = 0, \quad \frac{\partial T}{\partial \dot{x}_2} = m_2 \dot{x}_2, \quad \frac{d}{dt} \left(\frac{\partial T}{\partial \dot{x}_2} \right) = m_2 \ddot{x}_2, \quad \frac{\partial V}{\partial x_2} = k_2 (x_2 - x_1) - k_3 (x_3 - x_2)$$

$$\frac{\partial T}{\partial x_3} = 0, \quad \frac{\partial T}{\partial \dot{x}_3} = m_3 \dot{x}_3, \quad \frac{d}{dt} \left(\frac{\partial T}{\partial \dot{x}_3} \right) = m_3 \ddot{x}_3, \quad \frac{\partial V}{\partial x_3} = k_3 (x_3 - x_2) + k_4 x_3$$

Lagrange's equations give

$$m_1 \ddot{x}_1 + x_1 (k_1 + k_2) - k_2 x_2 = 0$$

$$m_2 \ddot{x}_2 - k_2 x_1 + x_2 (k_2 + k_3) - k_3 x_3 = 0$$

$$m_3 \ddot{x}_3 - k_3 x_2 + x_3 (k_3 + k_4) = 0$$

6.37 Using θ_1, θ_2 and θ_3 as generalized coordinates, we find

$$T \approx \frac{1}{2} m_1 (l_1 \dot{\theta}_1)^2 + \frac{1}{2} m_2 (l_1 \dot{\theta}_1 + l_2 \dot{\theta}_2)^2 + \frac{1}{2} m_3 (l_1 \dot{\theta}_1 + l_2 \dot{\theta}_2 + l_3 \dot{\theta}_3)^2 \dots \text{---} (E_1)$$

Let reference position correspond to $\theta_1 = \theta_2 = \theta_3 = 0$.

Vertical movement of m_1 is

$$l_1 (1 - \cos \theta_1) \approx l_1 \left\{ 1 - \left(1 - \frac{\theta_1^2}{2} \right) \right\} = \frac{1}{2} l_1 \theta_1^2$$

vertical movement of $m_2 = \frac{1}{2} l_1 \theta_1^2 + \frac{1}{2} l_2 \theta_2^2$

vertical movement of $m_3 = \frac{1}{2} l_1 \theta_1^2 + \frac{1}{2} l_2 \theta_2^2 + \frac{1}{2} l_3 \theta_3^2$

$$V = \frac{m_1 g l_1 \theta_1^2}{2} + \frac{m_2 g}{2} (l_1 \theta_1^2 + l_2 \theta_2^2) + \frac{m_3 g}{2} (l_1 \theta_1^2 + l_2 \theta_2^2 + l_3 \theta_3^2) \dots (E_2)$$

$$\frac{\partial T}{\partial \theta_1} = 0, \quad \frac{\partial T}{\partial \dot{\theta}_1} = m_1 l_1^2 \dot{\theta}_1 + m_2 l_1 (l_1 \dot{\theta}_1 + l_2 \dot{\theta}_2) + m_3 l_1 (l_1 \dot{\theta}_1 + l_2 \dot{\theta}_2 + l_3 \dot{\theta}_3),$$

$$\frac{d}{dt} \left(\frac{\partial T}{\partial \dot{\theta}_1} \right) = (m_1 + m_2 + m_3) l_1^2 \ddot{\theta}_1 + (m_2 + m_3) l_1 l_2 \ddot{\theta}_2 + m_3 l_1 l_3 \ddot{\theta}_3,$$

$$\frac{\partial V}{\partial \theta_1} = (m_1 + m_2 + m_3) g l_1 \theta_1$$

$$\frac{\partial T}{\partial \theta_2} = 0, \quad \frac{\partial T}{\partial \dot{\theta}_2} = m_2 l_2 (l_1 \dot{\theta}_1 + l_2 \dot{\theta}_2) + m_3 l_2 (l_1 \dot{\theta}_1 + l_2 \dot{\theta}_2 + l_3 \dot{\theta}_3),$$

$$\frac{d}{dt} \left(\frac{\partial T}{\partial \dot{\theta}_2} \right) = (m_2 + m_3) l_1 l_2 \ddot{\theta}_1 + (m_2 + m_3) l_2^2 \ddot{\theta}_2 + m_3 l_2 l_3 \ddot{\theta}_3,$$

$$\frac{\partial V}{\partial \theta_2} = m_2 g l_2 \theta_2 + m_3 g l_2 \theta_2 = (m_2 + m_3) g l_2 \theta_2$$

$$\frac{\partial T}{\partial \theta_3} = 0, \quad \frac{\partial T}{\partial \dot{\theta}_3} = m_3 l_3 (l_1 \dot{\theta}_1 + l_2 \dot{\theta}_2 + l_3 \dot{\theta}_3),$$

$$\frac{d}{dt} \left(\frac{\partial T}{\partial \dot{\theta}_3} \right) = m_3 l_3 (l_1 \ddot{\theta}_1 + l_2 \ddot{\theta}_2 + l_3 \ddot{\theta}_3), \quad \frac{\partial V}{\partial \theta_3} = m_3 g l_3 \theta_3$$

Lagrange's equations give the equations of motion

$$\begin{bmatrix} (m_1 + m_2 + m_3) l_1^2 & (m_2 + m_3) l_1 l_2 & m_3 l_1 l_3 \\ (m_2 + m_3) l_1 l_2 & (m_2 + m_3) l_2^2 & m_3 l_2 l_3 \\ m_3 l_1 l_3 & m_3 l_2 l_3 & m_3 l_3^2 \end{bmatrix} \begin{Bmatrix} \ddot{\theta}_1 \\ \ddot{\theta}_2 \\ \ddot{\theta}_3 \end{Bmatrix}$$

$$+ \begin{bmatrix} (m_1 + m_2 + m_3) g l_1 & 0 & 0 \\ 0 & (m_2 + m_3) g l_2 & 0 \\ 0 & 0 & m_3 g l_3 \end{bmatrix} \begin{Bmatrix} \theta_1 \\ \theta_2 \\ \theta_3 \end{Bmatrix} = \begin{Bmatrix} 0 \\ 0 \\ 0 \end{Bmatrix} \dots (E_3)$$

6.38

(a) Let generalized coordinates be $q_1 = x$ and $q_2 = \theta$

Displacement of mass M is $x + l\theta$.

Kinetic energy of airplane is $T = \frac{1}{2} M_0 \dot{x}^2 + 2 \left\{ \frac{1}{2} M (\dot{x} + l\dot{\theta})^2 \right\}$

Potential energy is $V = 2 \left(\frac{1}{2} k_t \theta^2 \right)$

Lagrange's equations are $\frac{d}{dt} \left(\frac{\partial T}{\partial \dot{q}_i} \right) - \frac{\partial T}{\partial q_i} + \frac{\partial V}{\partial q_i} = Q_i; \quad i = 1, 2$

Here $\frac{\partial T}{\partial x} = 0, \quad \frac{\partial T}{\partial \dot{x}} = M_0 \dot{x} + 2M(\dot{x} + l\dot{\theta}), \quad \frac{\partial V}{\partial x} = 0$

$$\frac{\partial T}{\partial \theta} = 0, \quad \frac{\partial T}{\partial \dot{\theta}} = 2Ml(\dot{x} + l\dot{\theta}), \quad \frac{\partial V}{\partial \theta} = 2k_t\theta, \quad Q_1 = Q_2 = 0$$

Hence Lagrange's equations become

$$\left. \begin{aligned} M_0 \ddot{x} + 2M(\ddot{x} + l\ddot{\theta}) &= 0 \\ 2Ml(\ddot{x} + l\ddot{\theta}) + 2k_t\theta &= 0 \end{aligned} \right\} \quad (E_1)$$

(b) If $x(t) = X \cos(\omega t + \phi)$ and $\theta(t) = \Theta \cos(\omega t + \phi)$, the equations of motion become

$$\left. \begin{aligned} (-M_0\omega^2 - 2M\omega^2)X - 2Ml\omega^2\Theta &= 0 \\ -2Ml\omega^2 X - 2Ml^2\omega^2\Theta + 2k_t\Theta &= 0 \end{aligned} \right\} \quad (E_2)$$

which yields the frequency equation:

$$\begin{vmatrix} M_0\omega^2 + 2M\omega^2 & 2Ml\omega^2 \\ 2Ml\omega^2 & 2Ml^2\omega^2 - 2k_t \end{vmatrix} = 0$$

i.e., $\omega^2 [2M_0Ml^2\omega^2 - 2M_0k_t - 4Mk_t] = 0$

i.e., $\omega^2 = 0$; $\omega^2 = \left(\frac{2M_0k_t + 4Mk_t}{2M_0Ml^2} \right)$

Mode shapes: Eq. (E₂) gives

$$\frac{\Theta}{X} = \frac{2Ml\omega^2}{-2Ml^2\omega^2 + 2k_t}$$

For $\omega_1 = 0$; $\frac{\Theta}{X} \Big|_{\omega_1} = \frac{0}{2k_t} = 0 \Rightarrow \Theta = 0$

This corresponds to rigid body translation in x (vertical) direction.

For ω_2 ; $\frac{\Theta}{X} \Big|_{\omega_2} = \frac{2Ml \left(\frac{2M_0k_t + 4Mk_t}{2M_0Ml^2} \right)}{-2Ml^2 \left(\frac{2M_0k_t + 4Mk_t}{2M_0Ml^2} \right) + 2k_t}$

$$= - \left(\frac{M_0}{2Ml} + \frac{1}{l} \right)$$

(c) For $\omega_2 > 4\pi$ rad/sec,

$$\left(\frac{2M_0k_t + 4Mk_t}{2M_0Ml^2} \right) > 16\pi^2 \quad (E_3)$$

When $M_0 = 1000 \text{ kg}$, $M = 500 \text{ kg}$ and $l = 6 \text{ m}$, inequality (E₃) becomes

$$\frac{2000 k_t + 2000 k_t}{(1 \times 10^6) (36)} > 16 \pi^2$$

i.e., $k_t > 1.4212 \times 10^6 \text{ N-m/rad.}$

6.39

Generalized coordinates: x_1, x_2, x_3 :

$$T = \frac{1}{2} m_1 \dot{x}_1^2 + \frac{1}{2} m_2 \dot{x}_2^2 + \frac{1}{2} m_3 \dot{x}_3^2$$

$$V = \frac{1}{2} k x_1^2 + \frac{1}{2} k (x_2 - x_1)^2 + \frac{1}{2} k (x_3 - x_2)^2 + \frac{1}{2} k x_3^2 + \frac{1}{2} (5k) (x_3 - x_1)^2$$

$$Q_i = F_i ; i = 1, 2, 3$$

$$\frac{\partial T}{\partial \dot{x}_i} = m_i \dot{x}_i ; i = 1, 2, 3$$

$$\frac{\partial V}{\partial x_1} = 7 k x_1 - k x_2 - 5 k x_3$$

$$\frac{d}{dt} \left(\frac{\partial T}{\partial \dot{x}_i} \right) = m_i \ddot{x}_i ; i = 1, 2, 3$$

$$\frac{\partial V}{\partial x_2} = -k x_1 + 2 k x_2 - k x_3$$

$$\frac{\partial T}{\partial x_i} = 0 ; i = 1, 2, 3$$

$$\frac{\partial V}{\partial x_3} = -5 k x_1 - k x_2 + 7 k x_3$$

Lagrange's equations yield the equations of motion:

$$m_1 \ddot{x}_1 + 7 k x_1 - k x_2 - 5 k x_3 = F_1(t)$$

$$m_2 \ddot{x}_2 - k x_1 + 2 k x_2 - k x_3 = F_2(t)$$

$$m_3 \ddot{x}_3 - 5 k x_1 - k x_2 + 7 k x_3 = F_3(t)$$

6.40

Generalized coordinates: θ, x_1, x_2 :

$$T = \frac{1}{2} J_0 \dot{\theta}^2 + \frac{1}{2} (2m) \dot{x}_1^2 + \frac{1}{2} m \dot{x}_2^2$$

$$\text{where } J_0 = \frac{1}{3} (2m) \ell^2 = \frac{2}{3} m \ell^2.$$

$$V = \frac{1}{2} (2k) \left(x_1 - \frac{\ell}{4} \theta \right)^2 + \frac{1}{2} k (x_2 - x_1)^2 + \frac{1}{2} (3k) (\theta \ell)^2$$

$$R = \frac{1}{2} c \left(\dot{x}_1 - \frac{\ell}{4} \dot{\theta} \right)^2$$

$$Q_\theta = M_t(t) ; Q_1 = F_1(t) ; Q_2 = F_2(t)$$

$$\frac{\partial T}{\partial \dot{\theta}} = J_0 \dot{\theta} ; \frac{\partial T}{\partial \dot{x}_1} = 2 m \dot{x}_1 ; \frac{\partial T}{\partial \dot{x}_2} = m \dot{x}_2$$

$$\frac{d}{dt} \left(\frac{\partial T}{\partial \dot{\theta}} \right) = J_0 \ddot{\theta} ; \quad \frac{d}{dt} \left(\frac{\partial T}{\partial \dot{x}_1} \right) = 2 m \ddot{x}_1 ; \quad \frac{d}{dt} \left(\frac{\partial T}{\partial \dot{x}_2} \right) = m \ddot{x}_2$$

$$\frac{\partial T}{\partial \theta} = 0 ; \quad \frac{\partial T}{\partial x_i} = 0 ; \quad i = 1, 2$$

$$\frac{\partial R}{\partial \dot{\theta}} = -c \frac{\ell}{4} (\dot{x}_1 - \dot{\theta} \frac{\ell}{4}) ; \quad \frac{\partial R}{\partial \dot{x}_1} = c (\dot{x}_1 - \dot{\theta} \frac{\ell}{4}) ; \quad \frac{\partial R}{\partial \dot{x}_2} = 0$$

$$\frac{\partial V}{\partial \theta} = \left(\frac{25}{8} k \ell^2 \right) \theta - \frac{1}{2} k \ell x_1$$

$$\frac{\partial V}{\partial x_1} = -\frac{1}{2} k \ell \theta + 3 k x_1 - k x_2$$

$$\frac{\partial V}{\partial x_2} = -k x_1 + k x_2$$

Lagrange's equations, Eqs. (6.118), yield the equations of motion as:

$$\begin{aligned} \frac{2}{3} m \ell^2 \ddot{\theta} + \frac{1}{16} c \ell^2 \dot{\theta} - \frac{1}{4} c \ell \dot{x}_1 + \frac{25}{8} k \ell^2 \theta - \frac{1}{2} k \ell x_1 &= M_t(t) \\ 2 m \ddot{x}_1 - \frac{1}{4} c \ell \dot{\theta} + c \dot{x}_1 - \frac{1}{2} k \ell \theta + 3 k x_1 - k x_2 &= F_2(t) \\ m \ddot{x}_2 - k x_1 + k x_2 &= F_2(t) \end{aligned}$$

6.41

Generalized coordinates: x_i ; $i = 1, 2, 3$:

$$\begin{aligned} T &= \frac{1}{2} J_G \dot{\theta}^2 + \frac{1}{2} (2m) \dot{x}_G^2 + \frac{1}{2} (5m) \dot{x}_2^2 \\ &= \frac{1}{2} \left(\frac{25}{6} m \ell^2 \right) \left(\frac{\dot{x}_1 - \dot{x}_3}{5 \ell} \right)^2 + \frac{1}{2} (2m) \left(\frac{\dot{x}_1 + \dot{x}_3}{2} \right)^2 + \frac{1}{2} (5m) \dot{x}_2^2 \end{aligned}$$

where the subscript G denotes the mass center of the bar with

$$J_G = \frac{1}{12} (2m) (5 \ell)^2 = \frac{25}{6} m \ell^2 ; \quad \theta = \frac{x_1 - x_3}{5 \ell} ; \quad x_G = \frac{x_1 + x_3}{2}$$

$$\begin{aligned} V &= \frac{1}{2} k x_1^2 + \frac{1}{2} k x_3^2 + \frac{1}{2} k (x_A - x_2)^2 \\ &= \frac{1}{2} k x_1^2 + \frac{1}{2} k x_3^2 + \frac{1}{2} k \left(\frac{3 x_1 + 2 x_3}{5} - x_2 \right)^2 \end{aligned}$$

$$\text{since } x_A = x_1 - \frac{2}{5} (x_1 - x_3) = \frac{3 x_1 + 2 x_3}{5}$$

$$R = \frac{1}{2} c (\dot{x}_A - \dot{x}_2)^2 = \frac{1}{2} c \left(\frac{3 \dot{x}_1 + 2 \dot{x}_3}{5} - \dot{x}_2 \right)^2$$

$$Q_i(t) = F_i(t) ; i = 1, 2, 3$$

$$\frac{\partial T}{\partial \dot{x}_1} = \left(\frac{25 m \ell^2}{6} \right) \left(\frac{1}{5 \ell} \right) \left(\frac{\dot{x}_1 - \dot{x}_3}{5 \ell} \right) + (2m) \frac{1}{2} \left(\frac{\dot{x}_1 + \dot{x}_3}{2} \right)$$

$$\frac{d}{dt} \left(\frac{\partial T}{\partial \dot{x}_1} \right) = \left(\frac{25 m \ell^2}{6} \right) \left(\frac{1}{25 \ell^2} \right) (\ddot{x}_1 - \ddot{x}_3) + \frac{m}{2} (\ddot{x}_1 + \ddot{x}_3)$$

$$\frac{\partial T}{\partial \dot{x}_2} = (5m) \dot{x}_2 ; \quad \frac{d}{dt} \left(\frac{\partial T}{\partial \dot{x}_2} \right) = (5m) \ddot{x}_2$$

$$\frac{\partial T}{\partial \dot{x}_3} = - \left(\frac{25 m \ell^2}{6} \right) \left(\frac{1}{5 \ell} \right) \left(\frac{\dot{x}_1 - \dot{x}_3}{5 \ell} \right) + (2m) \frac{1}{2} \left(\frac{\dot{x}_1 + \dot{x}_3}{2} \right)$$

$$\frac{d}{dt} \left(\frac{\partial T}{\partial \dot{x}_3} \right) = - \left(\frac{25 m \ell^2}{6} \right) \left(\frac{1}{25 \ell^2} \right) (\ddot{x}_1 - \ddot{x}_3) + \frac{m}{2} (\ddot{x}_1 + \ddot{x}_3)$$

$$\frac{\partial T}{\partial x_i} = 0 ; i = 1, 2, 3$$

$$\frac{\partial R}{\partial \dot{x}_1} = \frac{3}{5} c \left(\frac{3 \dot{x}_1 + 2 \dot{x}_3}{5} - \dot{x}_2 \right) \quad \frac{\partial V}{\partial x_1} = k x_1 + \frac{3}{5} k \left(\frac{3 x_1 + 2 x_3}{5} - x_2 \right)$$

$$\frac{\partial R}{\partial \dot{x}_3} = \frac{2}{5} c \left(\frac{3 \dot{x}_1 + 2 \dot{x}_3}{5} - \dot{x}_2 \right) \quad \frac{\partial V}{\partial x_2} = -k \left(\frac{3 x_1 + 2 x_3}{5} - x_2 \right)$$

$$\frac{\partial R}{\partial \dot{x}_2} = -c \left(\frac{3 \dot{x}_1 + 2 \dot{x}_3}{5} - \dot{x}_2 \right) \quad \frac{\partial V}{\partial x_3} = k x_3 + \frac{2}{5} k \left(\frac{3 x_1 + 2 x_3}{5} - x_2 \right)$$

Application of Lagrange's equations gives the equations of motion as:

$$\begin{aligned} \frac{2}{3} m \ddot{x}_1 + \frac{1}{3} m \ddot{x}_3 + \frac{9}{25} c \dot{x}_1 - \frac{3}{5} c \dot{x}_2 + \frac{6}{25} c \dot{x}_3 + \frac{34}{25} k x_1 - \frac{3}{5} k x_2 + \frac{6}{25} k x_3 &= F_1(t) \\ 5 m \ddot{x}_2 - \frac{3}{5} c \dot{x}_1 + c \dot{x}_2 - \frac{2}{5} c \dot{x}_3 - \frac{3}{5} k x_1 + k x_2 - \frac{2}{5} k x_3 &= F_2(t) \\ \frac{1}{3} m \ddot{x}_1 + \frac{2}{3} m \ddot{x}_3 + \frac{6}{25} c \dot{x}_1 - \frac{2}{5} c \dot{x}_2 + \frac{4}{25} c \dot{x}_3 + \frac{6}{25} k x_1 - \frac{2}{5} k x_2 + \frac{29}{25} k x_3 &= F_3(t) \end{aligned}$$

6.42

$$\begin{aligned} T &= \frac{1}{2} M \dot{x}_1^2 + \frac{1}{2} J_0 \dot{\theta}^2 + \frac{1}{2} (3m) \dot{x}_2^2 + \frac{1}{2} m \dot{x}_3^2 \\ V &= \frac{1}{2} k x_1^2 + \frac{1}{2} (2k) (x_1 - x_3 - r \theta)^2 + \frac{1}{2} (3k) x_3^2 \\ Q_i &= F_i ; i = 1, 2, 3 \end{aligned}$$

Noting that $\theta = \left(\frac{x_2 - x_1}{3 r} \right)$, we can express

$$\frac{\partial T}{\partial \dot{x}_1} = M \dot{x}_1 + J_0 \left(-\frac{1}{3r} \right) \left(\frac{\dot{x}_2 - \dot{x}_1}{3r} \right) ; \quad \frac{d}{dt} \left(\frac{\partial T}{\partial \dot{x}_1} \right) = M \ddot{x}_1 - \frac{J_0}{3r} \left(\frac{\ddot{x}_2 - \ddot{x}_1}{3r} \right)$$

$$\frac{\partial T}{\partial \dot{x}_2} = J_0 \left(\frac{1}{3r} \right) \left(\frac{\dot{x}_2 - \dot{x}_1}{3r} \right) + 3m \dot{x}_2 ; \quad \frac{d}{dt} \left(\frac{\partial T}{\partial \dot{x}_2} \right) = \frac{J_0}{9r^2} (\ddot{x}_2 - \ddot{x}_1) + 3m \ddot{x}_2$$

$$\frac{\partial T}{\partial \dot{x}_3} = m \dot{x}_3 ; \quad \frac{d}{dt} \left(\frac{\partial T}{\partial \dot{x}_3} \right) = m \ddot{x}_3$$

$$\frac{\partial V}{\partial x_1} = k x_1 + (2k) \frac{4}{3} \left(\frac{4}{3} x_1 - \frac{1}{3} x_2 - x_3 \right)$$

$$\frac{\partial V}{\partial x_2} = -\frac{1}{3} (2k) \left(\frac{4}{3} x_1 - \frac{1}{3} x_2 - x_3 \right)$$

$$\frac{\partial V}{\partial x_3} = -(2k) \left(\frac{4}{3} x_1 - \frac{1}{3} x_2 - x_3 \right) + (3k) x_3$$

Application of Lagrange's equations give the equations of motion:

$$\begin{aligned} \left(M + \frac{J_0}{9r^2} \right) \ddot{x}_1 - \frac{J_0}{9r^2} \ddot{x}_2 + \frac{41}{9} k x_1 - \frac{8}{9} k x_2 - \frac{8}{3} k x_3 &= F_1(t) \\ -\frac{J_0}{9r^2} \ddot{x}_1 + \left(3m + \frac{J_0}{9r^2} \right) \ddot{x}_2 - \frac{8}{9} k x_1 + \frac{2}{9} k x_2 + \frac{2}{3} k x_3 &= F_2(t) \\ m \ddot{x}_3 - \frac{8}{3} k x_1 + \frac{2}{3} k x_2 + 5k x_3 &= F_3(t) \end{aligned}$$

6.43

Generalized coordinates: θ_i ; $i = 1, 2, 3, 4$:

$$T = \frac{1}{2} I_1 \dot{\theta}_1^2 + \frac{1}{2} \left(I_2 + I_3 \frac{n_2^2}{n_3^2} \right) \dot{\theta}_2^2 + \frac{1}{2} \left(I_4 + I_5 \frac{n_4^2}{n_5^2} \right) \dot{\theta}_3^2 + \frac{1}{2} I_6 \dot{\theta}_4^2$$

$$V = \frac{1}{2} k_{t1} (\theta_2 - \theta_1)^2 + \frac{1}{2} k_{t2} \left(\theta_3 - \theta_2 \frac{n_2}{n_3} \right)^2 + \frac{1}{2} k_{t3} \left(\theta_4 - \theta_3 \frac{n_4}{n_5} \right)^2$$

$$Q_1 = M_1 \cos \omega t$$

$$\frac{\partial T}{\partial \dot{\theta}_1} = I_1 \dot{\theta}_1 ; \quad \frac{\partial T}{\partial \dot{\theta}_2} = \left(I_2 + I_3 \frac{n_2^2}{n_3^2} \right) \dot{\theta}_2$$

$$\frac{\partial T}{\partial \dot{\theta}_3} = \left(I_4 + I_5 \frac{n_4^2}{n_5^2} \right) \dot{\theta}_3 ; \quad \frac{\partial T}{\partial \dot{\theta}_4} = I_6 \dot{\theta}_4$$

$$\frac{d}{dt} \left(\frac{\partial T}{\partial \dot{\theta}_1} \right) = I_1 \ddot{\theta}_1 ; \quad \frac{d}{dt} \left(\frac{\partial T}{\partial \dot{\theta}_2} \right) = \left(I_2 + I_3 \frac{n_2^2}{n_3^2} \right) \ddot{\theta}_2$$

$$\frac{d}{dt} \left(\frac{\partial T}{\partial \dot{\theta}_3} \right) = \left(I_4 + I_5 \frac{n_4^2}{n_5^2} \right) \ddot{\theta}_3 ; \quad \frac{d}{dt} \left(\frac{\partial T}{\partial \dot{\theta}_4} \right) = I_6 \ddot{\theta}_4$$

$$\begin{aligned}\frac{\partial V}{\partial \theta_1} &= -k_{t1} (\theta_2 - \theta_1) \\ \frac{\partial V}{\partial \theta_2} &= k_{t1} (\theta_2 - \theta_1) - k_{t2} \left(\theta_3 - \theta_2 \frac{n_2}{n_3} \right) \frac{n_2}{n_3} \\ \frac{\partial V}{\partial \theta_3} &= k_{t2} \left(\theta_3 - \theta_2 \frac{n_2}{n_3} \right) - k_{t3} \left(\theta_4 - \theta_3 \frac{n_4}{n_5} \right) \frac{n_4}{n_5} \\ \frac{\partial V}{\partial \theta_4} &= k_{t3} \left(\theta_4 - \theta_3 \frac{n_4}{n_5} \right)\end{aligned}$$

Equations of motion (from Lagrange's equations):

$$\begin{aligned}I_1 \ddot{\theta}_1 - k_{t1} (\theta_2 - \theta_1) &= M_1 \cos \omega t \\ \left(I_2 + I_3 \frac{n_2^2}{n_3^2} \right) \ddot{\theta}_2 + k_{t1} (\theta_2 - \theta_1) - k_{t2} \left(\theta_3 - \theta_2 \frac{n_2}{n_3} \right) \frac{n_2}{n_3} &= 0 \\ \left(I_4 + I_5 \frac{n_4^2}{n_5^2} \right) \ddot{\theta}_3 + k_{t2} \left(\theta_3 - \theta_2 \frac{n_2}{n_3} \right) - k_{t3} \left(\theta_4 - \theta_3 \frac{n_4}{n_5} \right) \frac{n_4}{n_5} &= 0 \\ I_6 \ddot{\theta}_4 + k_{t3} \left(\theta_4 - \theta_3 \frac{n_4}{n_5} \right) &= 0\end{aligned}$$

6.44 Equations of motion for the system of Fig. 6.8(a) are:

$$m_1 \ddot{x}_1 + k_1 x_1 + k_2 (x_1 - x_2) = 0 \quad \text{--- (E}_1\text{)}$$

$$m_2 \ddot{x}_2 - k_2 (x_1 - x_2) + k_3 (x_2 - x_3) = 0 \quad \text{--- (E}_2\text{)}$$

$$m_3 \ddot{x}_3 - k_3 (x_2 - x_3) = 0 \quad \text{--- (E}_3\text{)}$$

Let $v_1 = x_1$, $v_2 = x_2 - x_1$ and $v_3 = x_3 - x_2$. Eqs. (E₁) to (E₃) become

$$m_1 \ddot{v}_1 + k_1 v_1 - k_2 v_2 = 0 \Rightarrow \ddot{v}_1 + \frac{k_1}{m_1} v_1 - \frac{k_2}{m_1} v_2 = 0 \quad \text{--- (E}_4\text{)}$$

$$m_2 \ddot{v}_2 + k_2 v_2 - k_3 v_3 = 0 \Rightarrow \ddot{v}_2 + \frac{k_2}{m_2} v_2 - \frac{k_3}{m_2} v_3 = 0 \quad \text{--- (E}_5\text{)}$$

$$m_3 \ddot{v}_3 + k_3 v_3 = 0 \Rightarrow \ddot{v}_3 + \frac{k_3}{m_3} v_3 = 0 \quad \text{--- (E}_6\text{)}$$

$$(E_4) \text{ minus } (E_5) \text{ gives } (\ddot{v}_2 - \ddot{v}_1) - \frac{k_1}{m_1} v_1 + \left(\frac{k_2}{m_2} + \frac{k_2}{m_1} \right) v_2 - \frac{k_3}{m_2} v_3 = 0 \quad \text{--- (E}_7\text{)}$$

$$(E_5) \text{ minus } (E_6) \text{ gives } (\ddot{v}_3 - \ddot{v}_2) - \frac{k_2}{m_2} v_2 + v_3 \left(\frac{k_3}{m_3} + \frac{k_3}{m_2} \right) = 0 \quad \text{--- (E}_8\text{)}$$

(E₄), (E₇) and (E₈) can be expressed as

$$\left. \begin{aligned}\ddot{v}_1 + \frac{k_1}{m_1} v_1 - \frac{k_2}{m_1} v_2 &= 0 \\ \ddot{v}_2 - \frac{k_1}{m_1} v_1 + \left(\frac{k_2}{m_2} + \frac{k_2}{m_1} \right) v_2 - \frac{k_3}{m_2} v_3 &= 0 \\ \ddot{v}_3 - \frac{k_2}{m_2} v_2 + \left(\frac{k_3}{m_3} + \frac{k_3}{m_2} \right) v_3 &= 0\end{aligned} \right\} \quad \text{--- (E}_9\text{)}$$

For $k_i = k$ and $m_i = m$ ($i = 1, 2, 3$), Eqs. (E₉) reduce to

$$\left. \begin{aligned} \ddot{v}_1 + \frac{k}{m} v_1 - \frac{k}{m} v_2 &= 0 \\ \ddot{v}_2 - \frac{k}{m} v_1 + 2 \frac{k}{m} v_2 - \frac{k}{m} v_3 &= 0 \\ \ddot{v}_3 - \frac{k}{m} v_1 + 2 \frac{k}{m} v_3 &= 0 \end{aligned} \right\} \dots (E_{10})$$

For $v_i(t) = Q_i \cos(\omega t + \phi)$; $i = 1, 2, 3$, (E₁₀) give

$$\begin{bmatrix} (-\omega^2 + \frac{k}{m}) & -\frac{k}{m} & 0 \\ -\frac{k}{m} & (-\omega^2 + 2\frac{k}{m}) & -\frac{k}{m} \\ 0 & -\frac{k}{m} & (-\omega^2 + 2\frac{k}{m}) \end{bmatrix} \begin{Bmatrix} Q_1 \\ Q_2 \\ Q_3 \end{Bmatrix} = \begin{Bmatrix} 0 \\ 0 \\ 0 \end{Bmatrix} \dots (E_{11})$$

Frequency equation is

$$\begin{vmatrix} -\omega^2 + \frac{k}{m} & -\frac{k}{m} & 0 \\ -\frac{k}{m} & -\omega^2 + 2\frac{k}{m} & -\frac{k}{m} \\ 0 & -\frac{k}{m} & -\omega^2 + 2\frac{k}{m} \end{vmatrix} = \omega^6 - 5\omega^4 \frac{k}{m} + 6\omega^2 \frac{k^2}{m^2} - \frac{k^3}{m^3} = 0$$

i.e. $\alpha^3 - 5\alpha^2 + 6\alpha - 1 = 0$ where $\alpha = \frac{\omega^2 m}{k}$.

Roots of this equation give

$$\alpha_1 = 0.19806, \quad \omega_1 = 0.44504 \sqrt{\frac{k}{m}}$$

$$\alpha_2 = 1.5553, \quad \omega_2 = 1.2471 \sqrt{\frac{k}{m}}$$

$$\alpha_3 = 3.2490, \quad \omega_3 = 1.8025 \sqrt{\frac{k}{m}}$$

It can be seen that the eigenvalues are same in both problems.

6.45

Equations of motion (from problem 6.19):

$$\begin{bmatrix} m_1 & 0 & 0 \\ 0 & m_2 & 0 \\ 0 & 0 & m_3 \end{bmatrix} \begin{Bmatrix} \ddot{x}_1 \\ \ddot{x}_2 \\ \ddot{x}_3 \end{Bmatrix} + \begin{bmatrix} k_1 + k_2 & -k_2 & 0 \\ -k_2 & k_2 + k_3 & -k_3 \\ 0 & -k_3 & k_3 + k_4 \end{bmatrix} \begin{Bmatrix} x_1 \\ x_2 \\ x_3 \end{Bmatrix} = \begin{Bmatrix} 0 \\ 0 \\ 0 \end{Bmatrix}$$

For harmonic motion $x_i(t) = X_i \cos(\omega t + \phi)$; $i = 1, 2, 3$, we get

$$\begin{bmatrix} -\omega^2 m_1 + k_1 + k_2 & -k_2 & 0 \\ -k_2 & -\omega^2 m_2 + k_2 + k_3 & -k_3 \\ 0 & -k_3 & -\omega^2 m_3 + k_3 + k_4 \end{bmatrix} \begin{Bmatrix} X_1 \\ X_2 \\ X_3 \end{Bmatrix} = \begin{Bmatrix} 0 \\ 0 \\ 0 \end{Bmatrix}$$

Frequency equation is

$$\begin{vmatrix} -\omega^2 m_1 + k_1 + k_2 & -k_2 & 0 \\ -k_2 & -\omega^2 m_2 + k_2 + k_3 & -k_3 \\ 0 & -k_3 & -\omega^2 m_3 + k_3 + k_4 \end{vmatrix} = 0$$

i.e. $(-\omega^2 m_1 + k_1 + k_2) \{ (-\omega^2 m_2 + k_2 + k_3)(-\omega^2 m_3 + k_3 + k_4) - k_3^2 \} + k_2 \{ -k_2(-\omega^2 m_3 + k_3 + k_4) \} = 0$

$$\text{i.e. } \omega^6 (m_1 m_2 m_3) - \omega^4 [m_1 m_2 (k_3 + k_4) + m_2 m_3 (k_1 + k_2) + m_1 m_3 (k_2 + k_3)] + \omega^2 [m_1 (k_2 + k_3)(k_3 + k_4) + m_2 (k_1 + k_2)(k_3 + k_4) + m_3 (k_1 + k_2)(k_2 + k_3) - m_1 k_3^2 - m_3 k_2^2] - [(k_1 + k_2)(k_2 + k_3)(k_3 + k_4) + (k_1 + k_2)k_3^2 + (k_3 + k_4)k_2^2] = 0$$

Equations of motion:

6.46

$$\begin{bmatrix} m_1 & 0 & 0 \\ 0 & m_2 & 0 \\ 0 & 0 & m_3 \end{bmatrix} \begin{Bmatrix} \ddot{x}_1 \\ \ddot{x}_2 \\ \ddot{x}_3 \end{Bmatrix} + \begin{bmatrix} k_1 + k_2 & -k_2 & 0 \\ -k_2 & k_2 + k_3 & -k_3 \\ 0 & -k_3 & k_3 \end{bmatrix} \begin{Bmatrix} x_1 \\ x_2 \\ x_3 \end{Bmatrix} = \begin{Bmatrix} 0 \\ 0 \\ 0 \end{Bmatrix} \quad \text{--- (E}_1\text{)}$$

For harmonic motion, we get

$$\begin{bmatrix} -\omega^2 m_1 + k_1 + k_2 & -k_2 & 0 \\ -k_2 & -\omega^2 m_2 + k_2 + k_3 & -k_3 \\ 0 & -k_3 & -\omega^2 m_3 + k_3 \end{bmatrix} \begin{Bmatrix} X_1 \\ X_2 \\ X_3 \end{Bmatrix} = \begin{Bmatrix} 0 \\ 0 \\ 0 \end{Bmatrix} \quad \text{--- (E}_2\text{)}$$

This gives the frequency equation (for $k_1 = k$, $k_2 = 2k$, $k_3 = 3k$, $m_1 = m$, $m_2 = 2m$ and $m_3 = 3m$)

$$\begin{vmatrix} -\omega^2 m + 3k & -2k & 0 \\ -2k & -2\omega^2 m + 5k & -3k \\ 0 & -3k & -3\omega^2 m + 3k \end{vmatrix} = 0 \quad \text{--- (E}_3\text{)}$$

$$\text{i.e. } (-\omega^2 m + 3k) [(-2\omega^2 m + 5k)(-3\omega^2 m + 3k) - 9k^2] + 2k [-2k(-3\omega^2 m + 3k)] = 0$$

$$\text{i.e. } 2\alpha^3 - 13\alpha^2 + 19\alpha - 2 = 0 \quad \text{where } \alpha = \frac{\omega^2 m}{k} \quad \text{--- (E}_4\text{)}$$

This gives the roots

$$\alpha_1 = 0.113992, \quad \alpha_2 = 2.00002, \quad \alpha_3 = 4.38600$$

$$\omega_1 = 0.337627 \sqrt{\frac{k}{m}}, \quad \omega_2 = 1.414221 \sqrt{\frac{k}{m}}, \quad \omega_3 = 2.094278 \sqrt{\frac{k}{m}}$$

Mode shape in j^{th} mode:

$$\text{Eq. (E}_2\text{) gives } \frac{X_2^{(j)}}{X_1^{(j)}} = \frac{-\omega_j^2 m_1 + k_1 + k_2}{k_2} = \frac{-\omega_j^2 m + 3k}{2k}$$

$$\frac{X_3^{(j)}}{X_2^{(j)}} = \frac{k_3}{-\omega_j^2 m_3 + k_3} = \frac{3k}{-3\omega_j^2 m + 3k}$$

$$\frac{X_3^{(j)}}{X_1^{(j)}} = \frac{X_3^{(j)}}{X_2^{(j)}} \cdot \frac{X_2^{(j)}}{X_1^{(j)}} = \frac{3(-\omega_j^2 m + 3k)}{2(-3\omega_j^2 m + 3k)}$$

$$\vec{X}^{(j)} = \begin{Bmatrix} X_1^{(j)} \\ X_2^{(j)} \\ X_3^{(j)} \end{Bmatrix} = X_1^{(j)} \begin{Bmatrix} 1 \\ (-\omega_j^2 m + 3k)/(2k) \\ 3(-\omega_j^2 m + 3k)/[2(-3\omega_j^2 m + 3k)] \end{Bmatrix} \quad \text{--- (E5)}$$

Thus

$$\vec{X}^{(1)} = X_1^{(1)} \begin{Bmatrix} 1.0 \\ 1.443004 \\ 1.628659 \end{Bmatrix}, \quad \vec{X}^{(2)} = X_1^{(2)} \begin{Bmatrix} 1.0 \\ 0.49999 \\ -0.49998 \end{Bmatrix}, \quad \vec{X}^{(3)} = X_1^{(3)} \begin{Bmatrix} 1.0 \\ -0.693 \\ 0.204666 \end{Bmatrix}$$

Mode shapes:

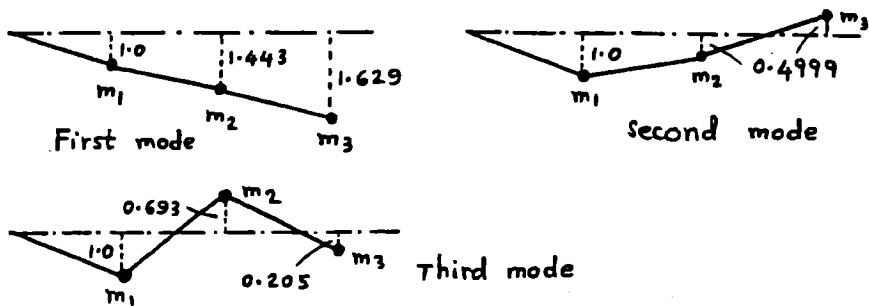

6.47

When $k_1 = 3k$, $k_2 = k_3 = k$, $m_1 = 3m$ and $m_2 = m_3 = m$, Eq. (E2) of problem 6.46 gives the frequency equation

$$\begin{vmatrix} -3m\omega^2 + 4k & -k & 0 \\ -k & -m\omega^2 + 2k & -k \\ 0 & -k & -m\omega^2 + k \end{vmatrix} = 0$$

i.e. $(-3m\omega^2 + 4k) [(-m\omega^2 + 2k)(-m\omega^2 + k) - k^2] + k[-k(-m\omega^2 + k)] = 0$

i.e. $3\alpha^3 - 13\alpha^2 + 14\alpha - 3 = 0 \quad \text{--- (E1)}$

where $\alpha = m\omega^2/k$. Roots of (E1) are

$\alpha_1 = 0.284515$, $\alpha_2 = 1.26053$, $\alpha_3 = 2.78829$

$\omega_1 = 0.533399 \sqrt{\frac{k}{m}}$, $\omega_2 = 1.122733 \sqrt{\frac{k}{m}}$, $\omega_3 = 1.669817 \sqrt{\frac{k}{m}}$

Eq. (E5) of problem 6.46 gives the j th mode shape as

$$\vec{X}^{(j)} = X_1^{(j)} \begin{Bmatrix} 1.0 \\ (-3m\omega_j^2 + 4k)/k \\ (-3m\omega_j^2 + 4k)/(-m\omega_j^2 + k) \end{Bmatrix}$$

Thus

$$\vec{X}^{(1)} = X_1^{(1)} \begin{Bmatrix} 1.0 \\ 3.146455 \\ 4.397653 \end{Bmatrix}, \quad \vec{X}^{(2)} = X_1^{(2)} \begin{Bmatrix} 1.0 \\ 0.21841 \\ -0.83833 \end{Bmatrix}, \quad \vec{X}^{(3)} = X_1^{(3)} \begin{Bmatrix} 1.0 \\ -4.36487 \\ 2.44081 \end{Bmatrix}$$

Orthogonality of normal modes:

$$[m] = m \begin{bmatrix} 3 & 0 & 0 \\ 0 & 1 & 0 \\ 0 & 0 & 1 \end{bmatrix}$$

$$\vec{X}^{(1)T} [m] \vec{X}^{(1)} = 1 \Rightarrow \begin{pmatrix} 1.0 & 3.146455 & 4.397653 \end{pmatrix} \begin{Bmatrix} 3.0 \\ 3.146455 \\ 4.397653 \end{Bmatrix} m X_1^{(1)2} = 1$$

$$\Rightarrow 32.239531 m X_1^{(1)2} = 1 \quad \text{or} \quad X_1^{(1)} = \frac{1}{\sqrt{m}} (0.176119)$$

$$\vec{X}^{(1)} = \frac{1}{\sqrt{m}} \begin{Bmatrix} 0.176119 \\ 0.554151 \\ 0.774510 \end{Bmatrix}$$

$$\vec{X}^{(2)T} [m] \vec{X}^{(2)} = 1 \Rightarrow \begin{pmatrix} 1.0 & 0.21841 & -0.83833 \end{pmatrix} \begin{Bmatrix} 3.0 \\ 0.21841 \\ -0.83833 \end{Bmatrix} m X_1^{(2)2} = 1$$

$$\Rightarrow 3.7505 m X_1^{(2)2} = 1 \quad \text{or} \quad X_1^{(2)} = \frac{1}{\sqrt{m}} (0.516363)$$

$$\vec{X}^{(2)} = \frac{1}{\sqrt{m}} \begin{Bmatrix} 0.516363 \\ 0.112779 \\ -0.432883 \end{Bmatrix}$$

$$\vec{X}^{(3)T} [m] \vec{X}^{(3)} = 1 \Rightarrow \begin{pmatrix} 1.0 & -4.36487 & 2.44081 \end{pmatrix} \begin{Bmatrix} 3.0 \\ -4.36487 \\ 2.44081 \end{Bmatrix} m X_1^{(3)2} = 1$$

$$\Rightarrow 28.00964 m X_1^{(3)2} = 1 \quad \text{or} \quad X_1^{(3)} = \frac{1}{\sqrt{m}} (0.18895)$$

$$\vec{X}^{(3)} = \frac{1}{\sqrt{m}} \begin{Bmatrix} 0.18895 \\ -0.824742 \\ 0.461191 \end{Bmatrix}$$

It can be verified that

$$\vec{X}^{(1)T} [m] \vec{X}^{(2)} = \begin{pmatrix} 0.176119 & 0.554151 & 0.774510 \end{pmatrix} \begin{Bmatrix} 1.549089 \\ 0.112779 \\ -0.432883 \end{Bmatrix} = 0$$

$$\vec{X}^{(1)T} [m] \vec{X}^{(3)} = \begin{pmatrix} 0.176119 & 0.554151 & 0.774510 \end{pmatrix} \begin{Bmatrix} 0.56685 \\ -0.824742 \\ 0.461191 \end{Bmatrix} = 0$$

$$\vec{X}^{(2)T} [m] \vec{X}^{(3)} = \begin{pmatrix} 0.516363 & 0.112779 & -0.432883 \end{pmatrix} \begin{Bmatrix} 0.56685 \\ -0.824742 \\ 0.461191 \end{Bmatrix} = 0$$

6.48

For $l_1 = 0.2 \text{ m}$, $l_2 = 0.3 \text{ m}$, $l_3 = 0.4 \text{ m}$, $m_1 = 1 \text{ kg}$, $m_2 = 2 \text{ kg}$ and $m_3 = 3 \text{ kg}$,

Eq. (E₃) of problem 6.37 gives the equations of motion

$$\begin{bmatrix} 6(0.04) & 5(0.06) & 3(0.08) \\ 5(0.06) & 5(0.09) & 3(0.12) \\ 3(0.08) & 3(0.12) & 3(0.16) \end{bmatrix} \begin{Bmatrix} \ddot{\theta}_1 \\ \ddot{\theta}_2 \\ \ddot{\theta}_3 \end{Bmatrix} + \begin{bmatrix} 6(9.81)(0.2) & 0 & 0 \\ 0 & 5(9.81)(0.3) & 0 \\ 0 & 0 & 3(9.81)(0.4) \end{bmatrix} \begin{Bmatrix} \theta_1 \\ \theta_2 \\ \theta_3 \end{Bmatrix} = \begin{Bmatrix} 0 \\ 0 \\ 0 \end{Bmatrix} \quad \text{--- (E}_1\text{)}$$

For harmonic motion, (E₁) becomes

$$-\omega^2 \begin{bmatrix} 0.24 & 0.30 & 0.24 \\ 0.30 & 0.45 & 0.36 \\ 0.24 & 0.36 & 0.48 \end{bmatrix} \begin{Bmatrix} \theta_1 \\ \theta_2 \\ \theta_3 \end{Bmatrix} + \begin{bmatrix} 11.772 & 0 & 0 \\ 0 & 14.715 & 0 \\ 0 & 0 & 11.772 \end{bmatrix} \begin{Bmatrix} \theta_1 \\ \theta_2 \\ \theta_3 \end{Bmatrix} = \begin{Bmatrix} 0 \\ 0 \\ 0 \end{Bmatrix} \quad \text{--- (E}_2\text{)}$$

This gives the frequency equation

$$\begin{vmatrix} \omega^2(0.24) - 11.772 & \omega^2(0.30) & \omega^2(0.24) \\ \omega^2(0.30) & \omega^2(0.45) - 14.715 & \omega^2(0.36) \\ \omega^2(0.24) & \omega^2(0.36) & \omega^2(0.48) - 11.772 \end{vmatrix} = 0$$

$$\begin{aligned} \text{i.e. } & (0.24\omega^2 - 11.772)[(0.45\omega^2 - 14.715)(0.48\omega^2 - 11.772) - (0.36)^2\omega^4] \\ & - 0.3\omega^2[0.3\omega^2(0.48\omega^2 - 11.772) - (0.24)(0.36)\omega^4] \\ & + 0.24\omega^2[(0.30)(0.36)\omega^4 - 0.24\omega^2(0.45\omega^2 - 14.715)] = 0 \end{aligned}$$

$$\text{i.e. } \omega^6 - 600.8625\omega^4 + 54132.806\omega^2 - 590047.6 = 0$$

Roots of this equation are

$$\omega_1^2 = 12.6335, \quad \omega_1 = 3.554364 \text{ rad/s}$$

$$\omega_2^2 = 94.6116, \quad \omega_2 = 9.726849 \text{ rad/s}$$

$$\omega_3^2 = 493.619, \quad \omega_3 = 22.217538 \text{ rad/s.}$$

6.49 (a) By replacing l by $\frac{l}{4}$ in problem 6.21, we obtain

$$[\omega] = \frac{l^3}{64EI} \begin{bmatrix} \frac{9}{64} & \frac{1}{6} & \frac{13}{192} \\ \frac{1}{6} & \frac{1}{3} & \frac{1}{6} \\ \frac{13}{192} & \frac{1}{6} & \frac{9}{64} \end{bmatrix}$$

$$[m] = m \begin{bmatrix} 1 & 0 & 0 \\ 0 & 1 & 0 \\ 0 & 0 & 1 \end{bmatrix}; [D] = [\omega][m] = \frac{ml^3}{EI} \begin{bmatrix} 0.0021975 & 0.0026042 & 0.0010579 \\ 0.0026042 & 0.0052083 & 0.0026042 \\ 0.0010579 & 0.0026042 & 0.0021973 \end{bmatrix}$$

Frequency equation is $[D] - \lambda[I] = 0$ where $\lambda = \frac{1}{\omega^2}$

$$\text{i.e. } \begin{vmatrix} 0.0021973 - \alpha & 0.0026042 & 0.0010579 \\ 0.0026042 & 0.0052083 - \alpha & 0.0026042 \\ 0.0010579 & 0.0026042 & 0.0021973 - \alpha \end{vmatrix} = 0 \quad \dots (E_1)$$

where $\alpha = \frac{EI}{ml^3\lambda} = \frac{EI}{ml^3\omega^2}$. $E_0 \cdot (E_1)$ gives

$$\begin{aligned} & (0.0021973 - \alpha)[(0.0052083 - \alpha)(0.0021973 - \alpha) - (0.0026042)^2] \\ & - (0.0026042)[0.0026042(0.0021973 - \alpha) - (0.0010579)(0.0026042)] \\ & + (0.0010579)[(0.0026042)^2 - (0.0010579)(0.0052083 - \alpha)] = 0 \end{aligned}$$

$$\text{i.e. } \alpha^3 - 0.96029 \times 10^{-2} \alpha^2 + 0.1303355 \times 10^{-4} \alpha - 0.0038623 \times 10^{-6} = 0$$

Roots are:

$$\alpha_1 = 0.000421453, \quad \omega_1 = 48.71082 \sqrt{EI/(ml^3)}$$

$$\alpha_2 = 0.00113955, \quad \omega_2 = 29.62329 \sqrt{EI/(ml^3)}$$

$$\alpha_3 = 0.00804192, \quad \omega_3 = 11.15116 \sqrt{EI/(ml^3)}$$

(b) $m = 10 \text{ kg}, \quad l = 0.5 \text{ m}, \quad E = 2.07 \times 10^{11} \text{ N/m}^2,$

$$I = \frac{\pi}{64} d^4 = \frac{\pi}{64} \left(\frac{2.5}{100}\right)^4 = 1.9175 \times 10^{-8} \text{ m}^4$$

$$\sqrt{\frac{EI}{ml^3}} = \sqrt{\frac{(2.07 \times 10^{11})(1.9175 \times 10^{-8})}{10(0.5)^3}} = 56.3505$$

$$\omega_3 = 48.71082(56.3505) = 2744.8791 \text{ rad/sec}$$

$$\omega_2 = 29.62329(56.3505) = 1669.2872 \text{ rad/sec}$$

$$\omega_1 = 11.15116(56.3505) = 628.3734 \text{ rad/sec}$$

(c) In order to have the same natural frequencies, we need to have the same value of I .

(i) For solid circular cross-section of diameter 2.5 cm,

$$I = 1.9175 \times 10^{-8} \text{ m}^4$$

(ii) For hollow circular section:

$$\text{let } d_o = 5t$$

$$I = \frac{\pi}{64} (d_o^4 - d_i^4) = \frac{\pi}{64} (625 - 81) t^4$$

$$= 26.7036 t^4 = 1.9175 \times 10^{-8}$$

$$t = 0.5177 \text{ cm}, \quad d_o = 2.5885 \text{ cm}, \quad d_i = 1.5531 \text{ cm}.$$

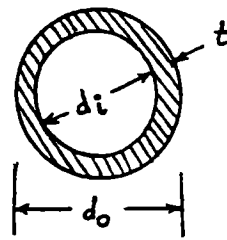

(iii) For solid rectangular section:

$$\text{Let } b = 2a.$$

$$I = \frac{1}{12} (a) b^3 = \frac{2}{3} a^4 = 1.9175 \times 10^{-8}$$

$$a = 1.3023 \text{ cm}, \quad b = 2.6046 \text{ cm}.$$

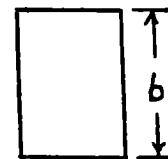

(iv) For hollow rectangular section:

$$\text{Let } b = 5t, \quad b_o = 3t$$

$$a = 2.5t, \quad a_o = 0.5t$$

$$I = \frac{1}{12} [ab^3 - a_o b_o^3]$$

$$= \frac{1}{12} [2.5(125) t^4 - (0.5)(27) t^4]$$

$$= 24.9167 t^4 = 1.9175 \times 10^{-8} \text{ m}^4$$

$$t = 0.5267 \text{ cm}, \quad a = 1.3167 \text{ cm}, \quad b = 2.6335 \text{ cm},$$

$$a_o = 0.2634 \text{ cm}, \quad b_o = 1.5801 \text{ cm}.$$

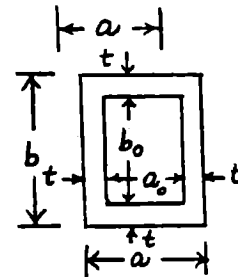

Weights:

Weights are proportional to cross-sectional areas.

(i) For solid circular section:

$$A = \frac{\pi}{4} d^2 = \frac{\pi}{4} (2.5)^2 = 4.90875 \text{ cm}^2$$

(ii) For hollow circular section:

$$A = \frac{\pi}{4} (d_o^2 - d_i^2) = \frac{\pi}{4} [2.5885^2 - 1.5531^2] = 3.3680 \text{ cm}^2$$

(iii) For solid rectangular section:

$$A = ab = (1.3023)(2.6046) = 3.3920 \text{ cm}^2$$

(iv) For hollow rectangular section:

$$A = ab - a_o b_o = (1.3167)(2.6335) - (0.2634)(1.5801) = 3.0513 \text{ cm}^2$$

\therefore Least weight beam will have a hollow rectangular section.

6.50

$$\begin{vmatrix} \lambda - 5 & -3 & -2 \\ -3 & \lambda - 6 & -4 \\ -1 & -2 & \lambda - 6 \end{vmatrix} = 0$$

$$\begin{aligned} \text{i.e. } & (\lambda - 5)[(\lambda - 6)^2 - (-2)(-4)] - (-3)[-3(\lambda - 6) - (-1)(-4)] \\ & + (-2)[-3(-2) - (-1)(\lambda - 6)] = 0 \end{aligned}$$

$$\text{i.e. } \lambda^3 - 17\lambda^2 + 77\lambda - 98 = 0$$

$$\text{Roots give: } \lambda_1 = 2.21398, \lambda_2 = 4.16929, \lambda_3 = 10.6168$$

6.51

From problem 6.19, for $k_i = k$; $i = 1, 2, 3, 4$,

$$[k] = k \begin{bmatrix} 2 & -1 & 0 \\ -1 & 2 & -1 \\ 0 & -1 & 2 \end{bmatrix}, \quad [m] = m \begin{bmatrix} 1 & 0 & 0 \\ 0 & 1 & 0 \\ 0 & 0 & 1 \end{bmatrix}$$

Equations of motion:

$$m \begin{bmatrix} 1 & 0 & 0 \\ 0 & 1 & 0 \\ 0 & 0 & 1 \end{bmatrix} \begin{Bmatrix} \ddot{x}_1 \\ \ddot{x}_2 \\ \ddot{x}_3 \end{Bmatrix} + k \begin{bmatrix} 2 & -1 & 0 \\ -1 & 2 & -1 \\ 0 & -1 & 2 \end{bmatrix} \begin{Bmatrix} x_1 \\ x_2 \\ x_3 \end{Bmatrix} = \begin{Bmatrix} 0 \\ 0 \\ 0 \end{Bmatrix}$$

These become, for harmonic motion,

$$\begin{bmatrix} -m\omega^2 + 2k & -k & 0 \\ -k & -m\omega^2 + 2k & -k \\ 0 & -k & -m\omega^2 + 2k \end{bmatrix} \begin{Bmatrix} X_1 \\ X_2 \\ X_3 \end{Bmatrix} = \begin{Bmatrix} 0 \\ 0 \\ 0 \end{Bmatrix} \quad \dots (E_1)$$

Frequency equation:

$$(-m\omega^2 + 2k)[(-m\omega^2 + 2k)^2 - k^2] + k[-k(-m\omega^2 + 2k)] = 0$$

$$\text{i.e. } (-\alpha + 2)(\alpha^2 - 4\alpha + 2) = 0 \quad \text{where } \alpha = \frac{m\omega^2}{k}$$

This gives $\alpha_1 = 2 - \sqrt{2} = 0.585786$, $\alpha_2 = 2$, $\alpha_3 = 3.414214$

$$\omega_1 = 0.765367 \sqrt{\frac{k}{m}}, \quad \omega_2 = 1.414214 \sqrt{\frac{k}{m}}, \quad \omega_3 = 1.847759 \sqrt{\frac{k}{m}}$$

(E₁) gives $x_2^{(j)} = \left(\frac{-m\omega_j^2 + 2k}{k} \right) x_1^{(j)}$

$$-k x_1^{(j)} + (-m\omega_j^2 + 2k) x_2^{(j)} - k x_3^{(j)} = 0$$

$$\text{or } \left[-k + (-m\omega_j^2 + 2k)^2 \cdot \frac{1}{k} \right] x_1^{(j)} - k x_3^{(j)} = 0$$

$$\text{or } x_3^{(j)} = \left\{ \frac{(-m\omega_j^2 + 2k)^2 - k^2}{k^2} \right\} x_1^{(j)}$$

$$j^{\text{th}} \text{ mode} = \vec{X}^{(j)} = \begin{Bmatrix} x_1^{(j)} \\ x_2^{(j)} \\ x_3^{(j)} \end{Bmatrix} = x_1^{(j)} \begin{Bmatrix} 1 \\ (-m\omega_j^2 + 2k)/k \\ [(-m\omega_j^2 + 2k)^2 - k^2]/k^2 \end{Bmatrix}$$

Mode shapes are:

$$\vec{X}^{(1)} = \begin{Bmatrix} 1 \\ 1.414214 \\ 1 \end{Bmatrix} x_1^{(1)}, \quad \vec{X}^{(2)} = \begin{Bmatrix} 1 \\ 0 \\ -1 \end{Bmatrix} x_1^{(2)}, \quad \vec{X}^{(3)} = \begin{Bmatrix} 1 \\ -1.414214 \\ 1 \end{Bmatrix} x_1^{(3)}$$

6.52

From problem 6.19,

$$[k] = \begin{bmatrix} 2k & -k & 0 \\ -k & 2k & -k \\ 0 & -k & 2k \end{bmatrix}, \quad [m] = \begin{bmatrix} 2m & 0 & 0 \\ 0 & 3m & 0 \\ 0 & 0 & 2m \end{bmatrix}$$

Equations of motion for harmonic motion:

$$\begin{bmatrix} -2m\omega^2 + 2k & -k & 0 \\ -k & -3m\omega^2 + 2k & -k \\ 0 & -k & -2m\omega^2 + 2k \end{bmatrix} \begin{Bmatrix} x_1 \\ x_2 \\ x_3 \end{Bmatrix} = \begin{Bmatrix} 0 \\ 0 \\ 0 \end{Bmatrix} \quad \text{---(E}_1\text{)}$$

Frequency equation:

$$(-2m\omega^2 + 2k) [(-3m\omega^2 + 2k)(-2m\omega^2 + 2k) - k^2] + k [-k(-2m\omega^2 + 2k)] = 0$$

$$\text{i.e. } (-m\omega^2 + k) [3m^2\omega^4 - 5km\omega^2 + k^2] = 0$$

$$\text{i.e. } (-\alpha + 1) (3\alpha^2 - 5\alpha + 1) = 0 \quad \text{where } \alpha = \frac{\omega^2 m}{k}$$

$$\therefore \alpha_1 = 0.232408, \quad \omega_1 = 0.482087 \sqrt{\frac{k}{m}}$$

$$\alpha_2 = 1.0, \quad \omega_2 = \sqrt{\frac{k}{m}}$$

$$\alpha_3 = 1.434258, \quad \omega_3 = 1.197605 \sqrt{\frac{k}{m}}$$

(E₁) gives $\frac{x_2^{(j)}}{x_1^{(j)}} = \frac{-2m\omega_j^2 + 2k}{k}$

$$(-3m\omega_j^2 + 2k) X_2^{(j)} - k X_3^{(j)} = k X_1^{(j)}$$

$$\text{or } (-3m\omega_j^2 + 2k) \left(\frac{-2m\omega_j^2 + 2k}{k} X_1^{(j)} \right) - k X_1^{(j)} = k X_3^{(j)}$$

$$\text{or } \frac{X_3^{(j)}}{X_1^{(j)}} = \frac{(-3m\omega_j^2 + 2k)(-2m\omega_j^2 + 2k) - k^2}{k^2}$$

$$j^{\text{th}} \text{ mode} = \vec{X}^{(j)} = X_1^{(j)} \begin{Bmatrix} 1.0 \\ (-2m\omega_j^2 + 2k)/k \\ \{(-3m\omega_j^2 + 2k)(-2m\omega_j^2 + 2k) - k^2\}/k^2 \end{Bmatrix}$$

This leads to:

$$\vec{X}^{(1)} = X_1^{(1)} \begin{Bmatrix} 1 \\ 1.535184 \\ 1 \end{Bmatrix}, \quad \vec{X}^{(2)} = X_1^{(2)} \begin{Bmatrix} 1 \\ 0 \\ -1 \end{Bmatrix}, \quad \vec{X}^{(3)} = X_1^{(3)} \begin{Bmatrix} -1 \\ -0.868516 \\ 1 \end{Bmatrix}$$

6.53 For $l_i = l$ and $m_i = m$ ($i = 1, 2, 3$), problem 6.37 gives

$$\begin{bmatrix} 3ml^2 & 2ml^2 & ml^2 \\ 2ml^2 & 2ml^2 & ml^2 \\ ml^2 & ml^2 & ml^2 \end{bmatrix} \begin{Bmatrix} \ddot{\theta}_1 \\ \ddot{\theta}_2 \\ \ddot{\theta}_3 \end{Bmatrix} + \begin{bmatrix} 3mgl & 0 & 0 \\ 0 & 2mgl & 0 \\ 0 & 0 & mgl \end{bmatrix} \begin{Bmatrix} \theta_1 \\ \theta_2 \\ \theta_3 \end{Bmatrix} = \begin{Bmatrix} 0 \\ 0 \\ 0 \end{Bmatrix}$$

For harmonic motion,

$$\begin{bmatrix} -3l\omega^2 + 3g & -2l\omega^2 & -l\omega^2 \\ -2l\omega^2 & -2l\omega^2 + 2g & -l\omega^2 \\ -l\omega^2 & -l\omega^2 & -l\omega^2 + g \end{bmatrix} \begin{Bmatrix} \theta_1 \\ \theta_2 \\ \theta_3 \end{Bmatrix} = \begin{Bmatrix} 0 \\ 0 \\ 0 \end{Bmatrix}$$

Dividing throughout by $-g$ and defining $\alpha = \frac{\omega^2 l}{g}$, this gives

$$\begin{bmatrix} 3\alpha - 3 & 2\alpha & \alpha \\ 2\alpha & 2\alpha - 2 & \alpha \\ \alpha & \alpha & \alpha - 1 \end{bmatrix} \begin{Bmatrix} \theta_1 \\ \theta_2 \\ \theta_3 \end{Bmatrix} = \begin{Bmatrix} 0 \\ 0 \\ 0 \end{Bmatrix} \quad \text{----- (E}_1\text{)}$$

Frequency equation:

$$(3\alpha - 3) [(2\alpha - 2)(\alpha - 1) - \alpha^2] - 2\alpha [2\alpha(\alpha - 1) - \alpha^2] + \alpha [2\alpha^2 - \alpha(2\alpha - 2)] = 0$$

i.e. $\alpha^3 - 9\alpha^2 + 18\alpha - 6 = 0$

Roots are:

$$\alpha_1 = 0.415764, \quad \omega_1 = 0.644798 \sqrt{\frac{g}{l}}$$

$$\alpha_2 = 2.29431, \quad \omega_2 = 1.514698 \sqrt{\frac{g}{l}}$$

$$\alpha_3 = 6.28995, \quad \omega_3 = 2.507977 \sqrt{\frac{g}{l}}$$

Mode shapes: (E₁) gives $\theta_2^{(j)} = \left\{ \frac{-2\alpha_j^2 + 6\alpha_j - 3}{\alpha_j(\alpha_j - 2)} \right\} \theta_1^{(j)}, \quad \theta_3^{(j)} = \left(\frac{\alpha_j - 3}{\alpha_j - 2} \right) \theta_1^{(j)}$

$$j^{\text{th}} \text{ mode} = \vec{w}^{(j)} = w_1^{(j)} \begin{Bmatrix} 1 \\ (-2\alpha_j^2 + 6\alpha_j - 3)/(\alpha_j^2 - 2\alpha_j) \\ (\alpha_j - 3)/(\alpha_j - 2) \end{Bmatrix}$$

Hence

$$\vec{w}^{(1)} = w_1^{(1)} \begin{Bmatrix} 1.0 \\ 1.2922 \\ 1.6312 \end{Bmatrix}, \quad \vec{w}^{(2)} = w_1^{(2)} \begin{Bmatrix} 1.0 \\ 0.3527 \\ -2.3978 \end{Bmatrix}, \quad \vec{w}^{(3)} = w_1^{(3)} \begin{Bmatrix} 1.0 \\ -1.6450 \\ 0.7669 \end{Bmatrix}$$

6.54

From problem 6.22 we find, for $m_1 = m_3 = m$, $m_2 = 2m$, $k_1 = k_2 = k$ and

$$k_3 = 2k,$$

$$[k] = \begin{bmatrix} 2k & -k & 0 \\ -k & 3k & -2k \\ 0 & -2k & 2k \end{bmatrix}, \quad [m] = \begin{bmatrix} m & 0 & 0 \\ 0 & 2m & 0 \\ 0 & 0 & m \end{bmatrix}$$

Equations of motion for harmonic motion

$$\begin{bmatrix} -\omega^2 m + 2k & -k & 0 \\ -k & -2m\omega^2 + 3k & -2k \\ 0 & -2k & -\omega^2 m + 2k \end{bmatrix} \begin{Bmatrix} X_1 \\ X_2 \\ X_3 \end{Bmatrix} = \begin{Bmatrix} 0 \\ 0 \\ 0 \end{Bmatrix} \quad \dots (E_1)$$

Frequency equation is

$$\begin{vmatrix} -\omega^2 m + 2k & -k & 0 \\ -k & -2m\omega^2 + 3k & -2k \\ 0 & -2k & -\omega^2 m + 2k \end{vmatrix} = 0$$

$$\text{or } (-\alpha + 2)(2\alpha^2 - 7\alpha + 1) = 0 \quad \text{with } \alpha = \frac{m\omega^2}{k}$$

$$\therefore \alpha_1 = 0.149219, \quad \omega_1 = 0.386289 \sqrt{k/m}$$

$$\alpha_2 = 2.0, \quad \omega_2 = 1.414214 \sqrt{k/m}$$

$$\alpha_3 = 3.350781, \quad \omega_3 = 1.830514 \sqrt{k/m}$$

Eq. (E₁) gives, for ω_j ,

$$\frac{X_2^{(j)}}{X_1^{(j)}} = \frac{-\omega_j^2 m + 2k}{k}$$

$$\frac{X_3^{(j)}}{X_1^{(j)}} = \frac{(-2m\omega_j^2 + 3k)(-m\omega_j^2 + 2k) - k^2}{2k^2}$$

$$j^{\text{th}} \text{ mode} = \vec{X}^{(j)} = X_1^{(j)} \begin{Bmatrix} 1.0 \\ (-\omega_j^2 m + 2k)/k \\ \{(-2m\omega_j^2 + 3k)(-m\omega_j^2 + 2k) - k^2\}/(2k^2) \end{Bmatrix}$$

Thus

$$\vec{X}^{(1)} = X_1^{(1)} \begin{Bmatrix} 1.0 \\ 1.850781 \\ 2.0 \end{Bmatrix}, \quad \vec{X}^{(2)} = X_1^{(2)} \begin{Bmatrix} 1.0 \\ 0.0 \\ -0.5 \end{Bmatrix}, \quad \vec{X}^{(3)} = X_1^{(3)} \begin{Bmatrix} 1.0 \\ -1.350781 \\ 2.0 \end{Bmatrix}$$

6.55

For $k_1 = 3k$, $k_2 = k_3 = k$, $m_1 = 4m$, $m_2 = 2m$ and $m_3 = m$, Eq. (E₂) of problem 6.46 gives

$$\begin{bmatrix} -4m\omega^2 + 4k & -k & 0 \\ -k & -2m\omega^2 + 2k & -k \\ 0 & -k & -m\omega^2 + k \end{bmatrix} \begin{Bmatrix} X_1 \\ X_2 \\ X_3 \end{Bmatrix} = \begin{Bmatrix} 0 \\ 0 \\ 0 \end{Bmatrix} \quad \dots (E_1)$$

Frequency equation:

$$(-4m\omega^2 + 4k) \{ (-2m\omega^2 + 2k)(-m\omega^2 + k) - k^2 \} + k \{ -k(-m\omega^2 + k) \} = 0$$

i.e. $(-\alpha + 1)(8\alpha^2 - 16\alpha + 3) = 0$ with $\alpha = \frac{m\omega^2}{k}$

$$\therefore \alpha_1 = 0.209431, \quad \omega_1 = 0.457636 \sqrt{k/m}$$

$$\alpha_2 = 1.0, \quad \omega_2 = \sqrt{k/m}$$

$$\alpha_3 = 1.790569, \quad \omega_3 = 1.338121 \sqrt{k/m}$$

Eq. (E₁) gives

$$X_2^{(j)} = \left\{ \frac{-4m\omega_j^2 + 4k}{k} \right\} X_1^{(j)}$$

$$X_3^{(j)} = \left[-1 + (-2m\omega_j^2 + 2k) \left(\frac{-4m\omega_j^2 + 4k}{k^2} \right) \right] X_1^{(j)}$$

$$j^{\text{th}} \text{ mode} = \vec{x}^{(j)} = X_1^{(j)} \begin{Bmatrix} 1.0 \\ (-4m\omega_j^2 + 4k)/k \\ \{ (-2m\omega_j^2 + 2k)(-4m\omega_j^2 + 4k) - k^2 \} / k^2 \end{Bmatrix}$$

Thus

$$\vec{x}^{(1)} = X_1^{(1)} \begin{Bmatrix} 1.0 \\ 3.162276 \\ 4.0 \end{Bmatrix}, \quad \vec{x}^{(2)} = X_1^{(2)} \begin{Bmatrix} 1.0 \\ 0.0 \\ -1.0 \end{Bmatrix}, \quad \vec{x}^{(3)} = X_1^{(3)} \begin{Bmatrix} 1.0 \\ -3.162276 \\ 4.0 \end{Bmatrix}$$

6.56

For $m_1 = 2m$, $m_2 = m$, $m_3 = 3m$ and $l_i = l$ for all i , problem 6.23 gives

$$a_{11} = \frac{1}{P(\frac{1}{l} + \frac{1}{3l})} = \frac{3l}{4P}, \quad a_{21} = \frac{2}{3} a_{11} = \frac{1}{2} \frac{l}{P}, \quad a_{31} = \frac{1}{3} a_{11} = \frac{1}{4} \frac{l}{P}$$

$$a_{22} = \frac{1}{P(\frac{1}{2l} + \frac{1}{2l})} = \frac{l}{P}, \quad a_{32} = \frac{1}{2} a_{22} = \frac{1}{2} \frac{l}{P}, \quad a_{33} = \frac{1}{P(\frac{1}{3l} + \frac{1}{l})} = \frac{3l}{4P}$$

$$[a] = \frac{l}{4P} \begin{bmatrix} 3 & 2 & 1 \\ 2 & 4 & 2 \\ 1 & 2 & 3 \end{bmatrix}, \quad [m] = m \begin{bmatrix} 2 & 0 & 0 \\ 0 & 1 & 0 \\ 0 & 0 & 3 \end{bmatrix}, \quad [a][m] = \frac{lm}{4P} \begin{bmatrix} 6 & 2 & 3 \\ 4 & 4 & 6 \\ 2 & 2 & 9 \end{bmatrix}$$

Equations of motion:

$$[a][m] \ddot{\vec{x}} + [I] \dot{\vec{x}} = \vec{0}$$

Frequency equation: $|- [a][m] \omega^2 + [I] | = 0$

i.e.
$$\left| -\frac{\omega^2 l m}{4 P} \begin{bmatrix} 6 & 2 & 3 \\ 4 & 4 & 6 \\ 2 & 2 & 9 \end{bmatrix} + \begin{bmatrix} 1 & 0 & 0 \\ 0 & 1 & 0 \\ 0 & 0 & 1 \end{bmatrix} \right| = 0$$

with $\alpha = \omega^2 l m / (4 P)$, this equation becomes

$$\begin{vmatrix} 6\alpha - 1 & 2\alpha & 3\alpha \\ 4\alpha & 4\alpha - 1 & 6\alpha \\ 2\alpha & 2\alpha & 9\alpha - 1 \end{vmatrix} = 96\alpha^3 - 88\alpha^2 + 19\alpha - 1 = 0$$

Roots are:

$$\begin{aligned} \alpha_1 &= 0.079126, & \omega_1 &= 0.562587 \sqrt{\frac{P}{l m}} \\ \alpha_2 &= 0.209671, & \omega_2 &= 0.915797 \sqrt{\frac{P}{l m}} \\ \alpha_3 &= 0.627872, & \omega_3 &= 1.584767 \sqrt{\frac{P}{l m}} \end{aligned}$$

6.57

For $(GJ)_i = GJ$, $J_{di} = J_0$ and $l_i = l$ for all i , problem 6.18 gives

$$[*] = \frac{GJ}{l} \begin{bmatrix} 2 & -1 & 0 \\ -1 & 2 & -1 \\ 0 & -1 & 2 \end{bmatrix}, \quad [J_d] = J_0 \begin{bmatrix} 1 & 0 & 0 \\ 0 & 1 & 0 \\ 0 & 0 & 1 \end{bmatrix}$$

Equations of motion for harmonic oscillation:

$$\begin{bmatrix} -\omega^2 J_0 + 2 \frac{GJ}{l} & -\frac{GJ}{l} & 0 \\ -\frac{GJ}{l} & -\omega^2 J_0 + 2 \frac{GJ}{l} & -\frac{GJ}{l} \\ 0 & -\frac{GJ}{l} & -\omega^2 J_0 + 2 \frac{GJ}{l} \end{bmatrix} \begin{Bmatrix} \Theta_1 \\ \Theta_2 \\ \Theta_3 \end{Bmatrix} = \begin{Bmatrix} 0 \\ 0 \\ 0 \end{Bmatrix} \quad \text{---(E}_1\text{)}$$

Dividing throughout by GJ/l and defining $\alpha = \frac{\omega^2 J_0 l}{GJ}$, (E₁) gives

$$\begin{bmatrix} -\alpha + 2 & -1 & 0 \\ -1 & -\alpha + 2 & -1 \\ 0 & -1 & -\alpha + 2 \end{bmatrix} \begin{Bmatrix} \Theta_1 \\ \Theta_2 \\ \Theta_3 \end{Bmatrix} = \begin{Bmatrix} 0 \\ 0 \\ 0 \end{Bmatrix} \quad \text{---(E}_2\text{)}$$

Frequency equation:

$$\begin{vmatrix} -\alpha + 2 & -1 & 0 \\ -1 & -\alpha + 2 & -1 \\ 0 & -1 & -\alpha + 2 \end{vmatrix} = (-\alpha + 2)(\alpha^2 - 4\alpha + 2) = 0$$

Roots are:

$$\begin{aligned} \alpha_1 &= 2 - \sqrt{2} = 0.585786, & \alpha_2 &= 2, & \alpha_3 &= 2 + \sqrt{2} = 3.414214 \\ \omega_1 &= 0.765367 \sqrt{\frac{GJ}{l J_0}}, & \omega_2 &= 1.414214 \sqrt{\frac{GJ}{l J_0}}, & \omega_3 &= 1.847759 \sqrt{\frac{GJ}{l J_0}} \end{aligned}$$

Noting that Eq. (E₁) is similar to Eq. (E₁) of problem 6.51, we can use the same modeshapes:

$$\vec{\Theta}^{(1)} = \Theta_1^{(1)} \begin{Bmatrix} 1.0 \\ 1.414214 \\ 1.0 \end{Bmatrix}, \quad \vec{\Theta}^{(2)} = \Theta_1^{(2)} \begin{Bmatrix} 1 \\ 0 \\ -1 \end{Bmatrix}, \quad \vec{\Theta}^{(3)} = \Theta_1^{(3)} \begin{Bmatrix} 1.0 \\ -1.414214 \\ 1.0 \end{Bmatrix}$$

6.58

Equations of motion

$$\frac{\rho A l}{4} \begin{bmatrix} 1 & 0 & 0 \\ 0 & 2 & 0 \\ 0 & 0 & 1 \end{bmatrix} \begin{Bmatrix} \ddot{x}_1 \\ \ddot{x}_2 \\ \ddot{x}_3 \end{Bmatrix} + \frac{2AE}{l} \begin{bmatrix} 1 & -1 & 0 \\ -1 & 2 & -1 \\ 0 & -1 & 1 \end{bmatrix} \begin{Bmatrix} x_1 \\ x_2 \\ x_3 \end{Bmatrix} = \begin{Bmatrix} 0 \\ 0 \\ 0 \end{Bmatrix} \quad \text{--- (E}_1\text{)}$$

This gives, for harmonic motion,

$$\begin{bmatrix} \left(-\frac{\omega^2 \rho A l}{4} + \frac{2AE}{l}\right) & -\frac{2AE}{l} & 0 \\ -\frac{2AE}{l} & \left(-\frac{2\omega^2 \rho A l}{4} + \frac{4AE}{l}\right) & -\frac{2AE}{l} \\ 0 & -\frac{2AE}{l} & \left(-\frac{\omega^2 \rho A l}{4} + \frac{2AE}{l}\right) \end{bmatrix} \begin{Bmatrix} x_1 \\ x_2 \\ x_3 \end{Bmatrix} = \begin{Bmatrix} 0 \\ 0 \\ 0 \end{Bmatrix} \quad \text{--- (E}_2\text{)}$$

Dividing throughout by $\frac{2AE}{l}$ and defining $\alpha = \frac{\omega^2 \rho A l}{2AE}$,

$$\begin{bmatrix} -\alpha+1 & -1 & 0 \\ -1 & -2\alpha+2 & -1 \\ 0 & -1 & -\alpha+1 \end{bmatrix} \begin{Bmatrix} x_1 \\ x_2 \\ x_3 \end{Bmatrix} = \begin{Bmatrix} 0 \\ 0 \\ 0 \end{Bmatrix} \quad \text{--- (E}_3\text{)}$$

Frequency equation:

$$\begin{vmatrix} -\alpha+1 & -1 & 0 \\ -1 & -2\alpha+2 & -1 \\ 0 & -1 & -\alpha+1 \end{vmatrix} = 2\alpha(-\alpha+1)(\alpha-2) = 0$$

$$\therefore \alpha_1 = 0, \quad \omega_1 = 0$$

$$\alpha_2 = 1, \quad \omega_2 = \sqrt{\frac{8AE}{\rho A l^2}}$$

$$\alpha_3 = 2, \quad \omega_3 = \sqrt{\frac{16AE}{\rho A l^2}}$$

Principal modes:

Eq. (E₃) gives $x_2^{(j)} = (-\alpha_j + 1) x_1^{(j)}$

$$x_3^{(j)} = [-1 + (-2\alpha_j + 2)(-\alpha_j + 1)] x_1^{(j)}$$

$$j^{\text{th}} \text{ mode: } \vec{x}^{(j)} = x_1^{(j)} \begin{Bmatrix} 1.0 \\ (-\alpha_j + 1) \\ 2(-\alpha_j + 1)^2 - 1 \end{Bmatrix}$$

Thus

$$\vec{x}^{(1)} = x_1^{(1)} \begin{Bmatrix} 1 \\ 1 \\ 1 \end{Bmatrix}, \quad \vec{x}^{(2)} = x_1^{(2)} \begin{Bmatrix} 1 \\ 0 \\ -1 \end{Bmatrix}, \quad \vec{x}^{(3)} = x_1^{(3)} \begin{Bmatrix} 1 \\ -1 \\ 1 \end{Bmatrix}$$

6.59

For orthonormalization, $\vec{x}^{(i)T} [m] \vec{x}^{(i)} = 1$; $i = 1, 2, 3$

Let new $\vec{x}^{(1)} = \alpha_1 \begin{Bmatrix} 1 \\ -1 \\ 1 \end{Bmatrix}$, $\vec{x}^{(2)} = \alpha_2 \begin{Bmatrix} 1 \\ 1 \\ 1 \end{Bmatrix}$ and $\vec{x}^{(3)} = \alpha_3 \begin{Bmatrix} 0 \\ 1 \\ 2 \end{Bmatrix}$

$$\vec{x}^{(1)T} [m] \vec{x}^{(1)} = \alpha_1^2 (1 \quad -1 \quad 1) \begin{bmatrix} 1 & 0 & 0 \\ 0 & 2 & 0 \\ 0 & 0 & 1 \end{bmatrix} \begin{Bmatrix} 1 \\ -1 \\ 1 \end{Bmatrix} = 4 \alpha_1^2 = 1 \Rightarrow \alpha_1 = \frac{1}{2}$$

$$\vec{x}^{(2)T} [m] \vec{x}^{(2)} = \alpha_2^2 (1 \quad 1 \quad 1) \begin{bmatrix} 1 & 0 & 0 \\ 0 & 2 & 0 \\ 0 & 0 & 1 \end{bmatrix} \begin{Bmatrix} 1 \\ 1 \\ 1 \end{Bmatrix} = 4 \alpha_2^2 = 1 \Rightarrow \alpha_2 = \frac{1}{2}$$

$$\vec{x}^{(3)T} [m] \vec{x}^{(3)} = \alpha_3^2 (0 \quad 1 \quad 2) \begin{bmatrix} 1 & 0 & 0 \\ 0 & 2 & 0 \\ 0 & 0 & 1 \end{bmatrix} \begin{Bmatrix} 0 \\ 1 \\ 2 \end{Bmatrix} = 6 \alpha_3^2 = 1 \Rightarrow \alpha_3 = \frac{1}{\sqrt{6}}$$

$$[m]\text{-orthonormal modal matrix} = [X] = \frac{1}{2} \begin{bmatrix} 1 & 1 & 0 \\ -1 & 1 & \sqrt{2/3} \\ 1 & 1 & \sqrt{8/3} \end{bmatrix}$$

6.60

Stiffness matrix:

Let $x_1=1, x_2=x_3=0$. $F_1=2+1+1=4=k_{11}$, $F_2=-1=k_{21}$, $F_3=-1=k_{31}$

Let $x_2=1, x_1=x_3=0$. $F_2=1+2=3=k_{22}$, $F_1=-1=k_{12}$, $F_3=0=k_{32}$

Let $x_3=1, x_1=x_2=0$. $F_3=1+1=2=k_{33}$, $F_1=-1=k_{13}$, $F_2=0=k_{23}$

$$\therefore [k] = \begin{bmatrix} 4 & -1 & -1 \\ -1 & 2 & 0 \\ -1 & 0 & 2 \end{bmatrix}$$

Mass matrix:

$$[m] = \begin{bmatrix} 2 & 0 & 0 \\ 0 & 1 & 0 \\ 0 & 0 & 1 \end{bmatrix}$$

(a) Characteristic polynomial:

$$\begin{vmatrix} (-2\omega^2+4) & -1 & -1 \\ -1 & (-\omega^2+2) & 0 \\ -1 & 0 & (-\omega^2+2) \end{vmatrix} = 0$$

$$\text{i.e. } 2(-\omega^2+1)(-\omega^2+2)(-\omega^2+3) = 0$$

$$\therefore \Delta(\omega^2) = 2(-\omega^2+1)(-\omega^2+2)(-\omega^2+3)$$

(b) Plot of $\Delta(\omega^2)$:

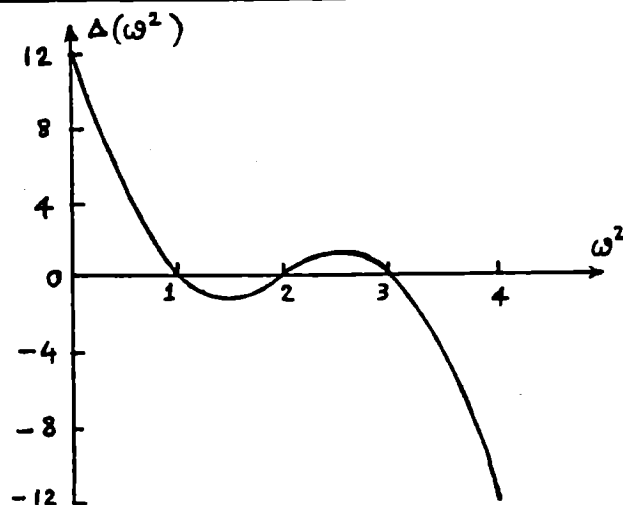

(c) Roots of equation:

$$\left. \begin{array}{l} \omega_1^2 = 1 \\ \omega_2^2 = 2 \\ \omega_3^2 = 3 \end{array} \right\} \text{from the graph.}$$

$$6.61 \quad (\omega) \quad \vec{X}^{(1)} = \begin{Bmatrix} 0.2754946 \\ 0.3994672 \\ 0.4490562 \end{Bmatrix}, \quad \vec{X}^{(2)} = \begin{Bmatrix} 0.6916979 \\ 0.2974301 \\ -0.3389320 \end{Bmatrix}, \quad [m] = \begin{bmatrix} 1 & 0 & 0 \\ 0 & 2 & 0 \\ 0 & 0 & 3 \end{bmatrix}$$

$$\vec{X}^{(1)T} [m] \vec{X}^{(2)} = (0.2754946 \quad 0.3994672 \quad 0.4490562) \begin{Bmatrix} 0.6916979 \\ 0.5948602 \\ -1.0167960 \end{Bmatrix} \approx 0$$

$$\text{Let } \vec{X}^{(3)} = \begin{Bmatrix} a_1 \\ a_2 \\ a_3 \end{Bmatrix}$$

$$\text{Then } \vec{X}^{(3)T} [m] \vec{X}^{(3)} = 1, \quad \vec{X}^{(1)T} [m] \vec{X}^{(3)} = 0, \quad \vec{X}^{(2)T} [m] \vec{X}^{(3)} = 0$$

These relations give

$$a_1^2 + 2a_2^2 + 3a_3^2 = 1 \quad \text{--- (E}_1\text{)}$$

$$0.2754946 a_1 + 0.7989344 a_2 + 1.3471686 a_3 = 0 \quad \text{--- (E}_2\text{)}$$

$$0.6916979 a_1 + 0.5948602 a_2 - 1.0167960 a_3 = 0 \quad \text{--- (E}_3\text{)}$$

From (E₂) and (E₃),

$$a_1 = -2.9000002 a_2 - 4.89 a_3 = -0.86 a_2 + 1.4700001 a_3$$

$$\text{or } a_2 = -3.1176468 a_3 \quad \text{--- (E}_4\text{)}$$

$$\text{and } a_1 = -2.9000002(-3.1176468 a_3) - 4.89 a_3 = 4.1511763 a_3 \quad \text{--- (E}_5\text{)}$$

(E₁), (E₄) and (E₅) give

$$a_3^2 (17.232265 + 9.7197216 + 1) = 1 \Rightarrow a_3 = \pm 0.1891445$$

$$\text{Hence } a_2 = \mp 0.5896857, \quad a_1 = \pm 0.7851722$$

$$\therefore \vec{X}^{(3)} = \begin{Bmatrix} 0.7851722 \\ -0.5896857 \\ 0.1891445 \end{Bmatrix}$$

$$(b) \quad \omega_i^2 = \vec{X}^{(i)T} [k] \vec{X}^{(i)} \quad ; \quad [k] = \begin{bmatrix} 6 & -4 & 0 \\ -4 & 10 & 0 \\ 0 & 0 & 6 \end{bmatrix}$$

$$\omega_1^2 = (0.2754946 \quad 0.3994672 \quad 0.4490562) \begin{Bmatrix} 0.05509889 \\ 2.8926938 \\ 2.6943374 \end{Bmatrix} = 2.3806248$$

$$\omega_2^2 = (0.6916979 \quad 0.2974301 \quad -0.3389320) \begin{Bmatrix} 2.9604671 \\ 0.2075095 \\ -2.0335920 \end{Bmatrix} = 2.7987180$$

$$\omega_3^2 = (0.7851722 \quad -0.5896857 \quad 0.1891445) \begin{Bmatrix} 7.0697761 \\ -9.0375462 \\ 1.1348671 \end{Bmatrix} = 11.094957$$

$$\therefore \omega_1 = 1.5429274, \quad \omega_2 = 1.6729369, \quad \omega_3 = 3.3309095.$$

6.62

From solution of Problem 6.1, we find

$$[m] = m \begin{bmatrix} 1 & 0 & 0 \\ 0 & 1 & 0 \\ 0 & 0 & 1 \end{bmatrix} \quad ; \quad [k] = k \begin{bmatrix} 7 & -1 & -5 \\ -1 & 2 & -1 \\ -5 & -1 & 7 \end{bmatrix}$$

Frequency equation:

$$|-\omega^2 [m] + [k]| = 0$$

$$\text{or } \begin{vmatrix} (-\alpha + 7) & -1 & -5 \\ -1 & (-\alpha + 2) & -1 \\ -5 & -1 & (-\alpha + 7) \end{vmatrix} = 0$$

where $\alpha = \frac{\omega^2 m}{k}$. Expansion of the frequency equation gives:

$$(-\alpha + 7) \left\{ (-\alpha + 2)(-\alpha + 7) - 1 \right\} + 1 \left\{ -(-\alpha + 7) - 5 \right\} - 5 \left\{ 1 + 5(-\alpha + 2) \right\} = 0$$

$$\text{or } \alpha^3 - 16\alpha^2 + 50\alpha - 24 = 0$$

Roots of this equation give:

$$\alpha_1 = 0.58576 ; \omega_1 = 0.7653 \sqrt{\frac{k}{m}}$$

$$\alpha_2 = 4.41428 ; \omega_2 = 1.8478 \sqrt{\frac{k}{m}}$$

$$\alpha_3 = 12.0 ; \omega_3 = 3.4641 \sqrt{\frac{k}{m}}$$

6.63

From the solution of Problem 6.2, we obtain:

$$[m] = \begin{bmatrix} \frac{2m\ell^2}{3} & 0 & 0 \\ 0 & 2m & 0 \\ 0 & 0 & m \end{bmatrix} = \begin{bmatrix} 0.6667 & 0 & 0 \\ 0 & 2 & 0 \\ 0 & 0 & 1 \end{bmatrix}$$

$$[k] = \begin{bmatrix} \frac{25k\ell^2}{8} & -\frac{k\ell}{2} & 0 \\ -\frac{k\ell}{2} & 3k & -k \\ 0 & -k & k \end{bmatrix} = \begin{bmatrix} 3125 & -500 & 0 \\ -500 & 3000 & -1000 \\ 0 & -1000 & 1000 \end{bmatrix}$$

Frequency equation:

$$|-\omega^2 [m] + [k]| = 0$$

$$\text{or } \begin{vmatrix} (3125 - 0.6667\omega^2) & -500 & 0 \\ -500 & (-2\omega^2 + 3000) & -1000 \\ 0 & -1000 & (1000 - \omega^2) \end{vmatrix} = 0$$

$$\text{or } (3125 - 0.6667 \omega^2) \left\{ (3000 - 2\omega^2)(1000 - \omega^2) - 1000^2 \right\} + 500 \left\{ -500(1000 - \omega^2) - 0 \right\} = 0$$

$$\text{or } -1.3334 \omega^5 + 9583.4 \omega^4 - 16.7083 (10^6) \omega^2 + 6.0 (10^9) = 0$$

Defining $\alpha = \left(\frac{\omega^2}{1000} \right)$, the above equation can be rewritten as

$$\alpha^3 - 7.1872 \alpha^2 + 12.5306 \alpha - 4.4998 = 0$$

Roots of this equation are (using Program):

$$\alpha_1 = 0.484831 ; \omega_1 = 22.0189 \text{ rad/sec}$$

$$\alpha_2 = 1.95501 ; \omega_2 = 44.2155 \text{ rad/sec}$$

$$\alpha_3 = 4.74738 ; \omega_3 = 68.9012 \text{ rad/sec}$$

6.64 $[m] = \begin{bmatrix} m_1 & 0 & 0 \\ 0 & m_2 & 0 \\ 0 & 0 & m_3 \end{bmatrix} = \begin{bmatrix} m & 0 & 0 \\ 0 & 2m & 0 \\ 0 & 0 & 3m \end{bmatrix}, [k] = \begin{bmatrix} k_1 & -k_1 & 0 \\ -k_1 & (k_1+k_2) & -k_2 \\ 0 & -k_2 & k_2 \end{bmatrix} = \begin{bmatrix} k & -k & 0 \\ -k & 2k & -k \\ 0 & -k & k \end{bmatrix}$

Equations of motion for harmonic motion:

$$\begin{bmatrix} (-m\omega^2 + k) & -k & 0 \\ -k & (-2m\omega^2 + 2k) & -k \\ 0 & -k & (-3m\omega^2 + k) \end{bmatrix} \begin{Bmatrix} X_1 \\ X_2 \\ X_3 \end{Bmatrix} = \begin{Bmatrix} 0 \\ 0 \\ 0 \end{Bmatrix} \quad (E.1)$$

Defining $\alpha = \frac{m\omega^2}{k}$, (E.1) can be rewritten as

$$\begin{bmatrix} (-\alpha + 1) & -1 & 0 \\ -1 & (-2\alpha + 2) & -1 \\ 0 & -1 & (-3\alpha + 1) \end{bmatrix} \begin{Bmatrix} X_1 \\ X_2 \\ X_3 \end{Bmatrix} = \begin{Bmatrix} 0 \\ 0 \\ 0 \end{Bmatrix} \quad (E.2)$$

Frequency equation is

$$2\alpha (3\alpha^2 - 7\alpha + 3) = 0$$

Roots are

$$\alpha_1 = 0 ; \omega_1 = 0$$

$$\alpha_2 = 0.565741 ; \omega_2 = 0.752158 \sqrt{k/m}$$

$$\alpha_3 = 1.767592 ; \omega_3 = 1.329508 \sqrt{k/m}$$

Eqs. (E.2) give

$$X_2^{(j)} = (-\alpha_j + 1) X_1^{(j)}, \quad X_3^{(j)} = \left(\frac{1}{-3\alpha_j + 1} \right) X_2^{(j)}$$

$$\therefore \vec{X}^{(j)} = \begin{Bmatrix} 1.0 \\ (-\alpha_j + 1) \\ \left(\frac{1}{-3\alpha_j + 1} \right) \end{Bmatrix} X_1^{(j)}$$

Hence

$$\vec{X}^{(1)} = \begin{Bmatrix} 1 \\ 1 \\ 1 \end{Bmatrix} X_1^{(1)}, \quad \vec{X}^{(2)} = \begin{Bmatrix} 1 \\ 0.434259 \\ -0.622841 \end{Bmatrix} X_1^{(2)}, \quad \vec{X}^{(3)} = \begin{Bmatrix} 1 \\ -0.767592 \\ 0.178395 \end{Bmatrix} X_1^{(3)}$$

$$6.65 \quad [k_t] = k_t \begin{bmatrix} 1 & -1 & 0 \\ -1 & 3 & -2 \\ 0 & -2 & 2 \end{bmatrix}, \quad [J] = J_0 \begin{bmatrix} 1 & 0 & 0 \\ 0 & 1 & 0 \\ 0 & 0 & 1 \end{bmatrix}$$

With $\alpha = \frac{\omega^2 J_0}{k_t}$, the equations of motion for harmonic motion become

$$\begin{bmatrix} (-\alpha+1) & -1 & 0 \\ -1 & (-\alpha+3) & -2 \\ 0 & -2 & (-\alpha+2) \end{bmatrix} \begin{Bmatrix} \Theta_1 \\ \Theta_2 \\ \Theta_3 \end{Bmatrix} = \begin{Bmatrix} 0 \\ 0 \\ 0 \end{Bmatrix} \quad (E.1)$$

Frequency equation is

$$\alpha(\alpha^2 - 6\alpha + 6) = 0$$

Roots are:

$$\alpha_1 = 0, \quad \alpha_2 = 1.267949, \quad \alpha_3 = 4.732051$$

$$\omega_1 = 0, \quad \omega_2 = 1.126032 \sqrt{k_t/J_0}, \quad \omega_3 = 2.175328 \sqrt{k_t/J_0}$$

Eq. (E.1) gives

$$\Theta_2^{(j)} = (-\alpha_j + 1) \Theta_1^{(j)}, \quad \Theta_3^{(j)} = \frac{2}{(-\alpha_j + 2)} \Theta_1^{(j)}$$

$$\vec{\Theta}^{(j)} = \begin{Bmatrix} 1 \\ (-\alpha_j + 1) \\ \left(\frac{-2}{-\alpha_j + 2}\right) \end{Bmatrix} \Theta_1^{(j)}$$

$$\therefore \vec{\Theta}^{(1)} = \begin{Bmatrix} 1 \\ 1 \\ 1 \end{Bmatrix} \Theta_1^{(1)}, \quad \vec{\Theta}^{(2)} = \begin{Bmatrix} 1 \\ -0.267949 \\ -0.732050 \end{Bmatrix} \Theta_1^{(2)}, \quad \vec{\Theta}^{(3)} = \begin{Bmatrix} 1 \\ -3.732051 \\ 2.732051 \end{Bmatrix} \Theta_1^{(3)}$$

Normalize the eigenvectors with respect to the inertia matrix as

$$\vec{\Theta}^{(1)T} [J] \vec{\Theta}^{(1)} = \Theta_1^{(1)2} J_0 (1 \ 1 \ 1) \begin{Bmatrix} 1 \\ 1 \\ 1 \end{Bmatrix} = 3 J_0 \Theta_1^{(1)2} = 1$$

$$\Theta_1^{(1)} = 0.57735 / \sqrt{J_0}$$

$$\begin{aligned} \vec{\Theta}^{(2)T} [J] \vec{\Theta}^{(2)} &= \Theta_1^{(2)2} J_0 (1 \ -0.267949 \ -0.732050) \begin{Bmatrix} 1 \\ -0.267949 \\ -0.732050 \end{Bmatrix} \\ &= \Theta_1^{(2)2} J_0 (1.607694) = 1 \end{aligned}$$

$$\Theta_1^{(2)} = 0.788675 / \sqrt{J_0}$$

$$\begin{aligned} \vec{\Theta}^{(3)T} [J] \vec{\Theta}^{(3)} &= \Theta_1^{(3)2} J_0 (1 \ -3.732051 \ 2.732051) \begin{Bmatrix} 1 \\ -3.732051 \\ 2.732051 \end{Bmatrix} \\ &= \Theta_1^{(3)2} J_0 (22.392307) \end{aligned}$$

$$\Theta_1^{(3)} = 0.211325 / \sqrt{J_0}$$

Modal matrix is

$$[X] = \frac{1}{\sqrt{J_0}} \begin{bmatrix} 0.57735 & 0.788675 & 0.211325 \\ 0.57735 & -0.211325 & -0.788676 \\ 0.57735 & -0.577349 & 0.577351 \end{bmatrix}$$

6.66

From solution of Problem 6.52, the natural frequencies and mode shapes are given by:

$$\omega_1 = 0.482087 \sqrt{\frac{k}{m}} ; \omega_2 = \sqrt{\frac{k}{m}} ; \omega_3 = 1.197605 \sqrt{\frac{k}{m}}$$

$$\vec{X}^{(1)} = \begin{Bmatrix} 1.0 \\ 1.535184 \\ 1.0 \end{Bmatrix} ; \vec{X}^{(2)} = \begin{Bmatrix} 1 \\ 0 \\ -1 \end{Bmatrix} ; \vec{X}^{(3)} = \begin{Bmatrix} 1.0 \\ 0.868516 \\ -1 \end{Bmatrix}$$

Initial conditions:

$$x_1(0) = x_{10}, x_2(0) = 0, x_3(0) = 0, \dot{x}_i(0) = 0 ; i = 1, 2, 3$$

Equations (6.98) and (6.99) yield:

$$A_1 \cos \phi_1 + A_2 \cos \phi_2 + A_3 \cos \phi_3 = x_{10} \quad (1)$$

$$1.5352 A_1 \cos \phi_1 + 0.8685 A_3 \cos \phi_3 = 0 \quad (2)$$

$$A_1 \cos \phi_1 - A_2 \cos \phi_2 - A_3 \cos \phi_3 = 0 \quad (3)$$

$$-0.4821 \sqrt{\frac{k}{m}} A_1 \sin \phi_1 - \sqrt{\frac{k}{m}} A_2 \sin \phi_2 - 1.1976 \sqrt{\frac{k}{m}} A_3 \sin \phi_3 = 0 \quad (4)$$

$$-0.4821 \sqrt{\frac{k}{m}} (1.5352) A_1 \sin \phi_1 - 1.1976 \sqrt{\frac{k}{m}} (0.8685) A_3 \sin \phi_3 = 0 \quad (5)$$

$$-0.4821 \sqrt{\frac{k}{m}} (1.0) A_1 \sin \phi_1 - \sqrt{\frac{k}{m}} (-1) A_2 \sin \phi_2 - 1.1976 \sqrt{\frac{k}{m}} (-1) A_3 \sin \phi_3 = 0 \quad (6)$$

Solution of Eqs. (4) to (6):

$$\phi_i = 0 ; i = 1, 2, 3$$

Solution of Eqs. (1) to (3) gives:

$$A_1 = 0.5 x_{10} ; A_2 = 0.3838 x_{10} ; A_3 = -0.8838 x_{10}$$

Thus the free vibration solution of the system is given by:

$$x_1(t) = x_{10} \left(0.5 \cos 0.4821 \sqrt{\frac{k}{m}} t + 0.3838 \cos \sqrt{\frac{k}{m}} t - 0.8838 \cos 1.1976 \sqrt{\frac{k}{m}} t \right)$$

$$x_2(t) = x_{10} \left\{ 0.7676 \cos 0.4821 \sqrt{\frac{k}{m}} t - 0.7676 \cos 1.1976 \sqrt{\frac{k}{m}} t \right\}$$

$$x_3(t) = x_{10} \left(0.5 \cos 0.4821 \sqrt{\frac{k}{m}} t - 0.3838 \cos \sqrt{\frac{k}{m}} t + 0.8838 \cos 1.1976 \sqrt{\frac{k}{m}} t \right)$$

6.67

From solution of Problem 6.53, we find that:

$$\omega_1 = 0.6448 \sqrt{\frac{g}{\ell}} ; \omega_2 = 1.5147 \sqrt{\frac{g}{\ell}} ; \omega_3 = 2.5080 \sqrt{\frac{g}{\ell}}$$

$$\vec{X}^{(1)} = \begin{Bmatrix} 1.0 \\ 1.2922 \\ 1.6312 \end{Bmatrix} ; \vec{X}^{(2)} = \begin{Bmatrix} 1.0 \\ 0.3527 \\ -2.3978 \end{Bmatrix} ; \vec{X}^{(3)} = \begin{Bmatrix} 1.0 \\ -1.6450 \\ 0.7669 \end{Bmatrix}$$

Equations (6.98) and (6.99) can be written, for the stated initial conditions, as:

$$A_1 \cos \phi_1 + A_2 \cos \phi_2 + A_3 \cos \phi_3 = 0 \quad (1)$$

$$1.2922 A_1 \cos \phi_1 + 0.3527 A_2 \cos \phi_2 - 1.6450 A_3 \cos \phi_3 = 0 \quad (2)$$

$$1.6312 A_1 \cos \phi_1 - 2.3978 A_2 \cos \phi_2 + 0.7669 A_3 \cos \phi_3 = \theta_{30} \quad (3)$$

$$\begin{aligned} & -0.6448 \sqrt{\frac{g}{\ell}} A_1 \sin \phi_1 - 1.5147 \sqrt{\frac{g}{\ell}} A_2 \sin \phi_2 \\ & \quad - 2.5080 \sqrt{\frac{g}{\ell}} A_3 \sin \phi_3 = 0 \end{aligned} \quad (4)$$

$$\begin{aligned} & -0.6448 \sqrt{\frac{g}{\ell}} (1.2922) A_1 \sin \phi_1 - 1.5147 \sqrt{\frac{g}{\ell}} (0.3527) A_2 \sin \phi_2 \\ & \quad - 2.5080 \sqrt{\frac{g}{\ell}} (-1.6450) A_3 \sin \phi_3 = 0 \end{aligned} \quad (5)$$

$$\begin{aligned} & -0.6448 \sqrt{\frac{g}{\ell}} (1.6312) A_1 \sin \phi_1 - 1.5147 \sqrt{\frac{g}{\ell}} (-2.3978) A_2 \sin \phi_2 \\ & \quad - 2.5080 \sqrt{\frac{g}{\ell}} (0.7669) A_3 \sin \phi_3 = 0 \end{aligned} \quad (6)$$

Equations (4) to (6) yield:

$$\phi_i = 0 ; i = 1, 2, 3$$

Equations (1) to (3) give

$$A_1 = 0.1812 x_{30} ; A_2 = -0.2665 x_{30} ; A_3 = 0.08524 x_{30}$$

Thus the free vibration solution can be expressed as (see Eq. (6.96)):

$$\begin{aligned} x_1(t) = x_{30} & (0.1812 \cos 0.6448 \sqrt{\frac{g}{\ell}} t - 0.2665 \cos 1.5147 \sqrt{\frac{g}{\ell}} t \\ & + 0.08524 \cos 2.5080 \sqrt{\frac{g}{\ell}} t) \end{aligned} \quad (7)$$

$$\begin{aligned} x_2(t) = x_{30} & (0.2341 \cos 0.6448 \sqrt{\frac{g}{\ell}} t - 0.09399 \cos 1.5147 \sqrt{\frac{g}{\ell}} t \\ & - 0.1402 \cos 2.5080 \sqrt{\frac{g}{\ell}} t) \end{aligned} \quad (8)$$

$$\begin{aligned} x_3(t) = x_{30} & (0.2956 \cos 0.6448 \sqrt{\frac{g}{\ell}} t + 0.6390 \cos 1.5147 \sqrt{\frac{g}{\ell}} t \\ & + 0.06537 \cos 2.5080 \sqrt{\frac{g}{\ell}} t) \end{aligned} \quad (9)$$

6.68

From solution of Problem 6.56, we obtain

$$\omega_1 = 0.5626 \sqrt{\frac{P}{\ell m}} ; \omega_2 = 0.9158 \sqrt{\frac{P}{\ell m}} ; \omega_3 = 1.5848 \sqrt{\frac{P}{\ell m}}$$

$$\alpha_1 = \frac{\omega_1^2 \ell m}{4 P} = 0.079126 ; \alpha_2 = \frac{\omega_2^2 \ell m}{4 P} = 0.209671 ; \alpha_3 = \frac{\omega_3^2 \ell m}{4 P} = 0.627872$$

The mode shapes can be determined from the equations:

$$(6 \alpha - 1) X_1 + 2 \alpha X_2 + 3 \alpha X_3 = 0 \quad (1)$$

$$4 \alpha X_1 + (4 \alpha - 1) X_2 + 6 \alpha X_3 = 0 \quad (2)$$

$$2 \alpha X_1 + 2 \alpha X_2 + (9 \alpha - 1) X_3 = 0 \quad (3)$$

$$\text{Let } X_1 = 1 \quad (4)$$

Then Eqs. (1) and (2) yield

$$X_2 = 2 - 8 \alpha \quad (5)$$

$$X_3 = \frac{1 - 10 \alpha + 16 \alpha^2}{3 \alpha} \quad (6)$$

Using the values of α_1 , α_2 and α_3 , we obtain, from Eqs. (4) to (6):

$$\vec{X}^{(1)} = \begin{Bmatrix} 1 \\ 1.3670 \\ 1.3014 \end{Bmatrix} ; \vec{X}^{(2)} = \begin{Bmatrix} 1 \\ 0.3226 \\ -0.6253 \end{Bmatrix} ; \vec{X}^{(3)} = \begin{Bmatrix} 1 \\ -3.0230 \\ 0.5462 \end{Bmatrix}$$

The stated initial conditions give, using Eqs. (6.98) and (6.99),

$$A_1 \cos \phi_1 + A_2 \cos \phi_2 + A_3 \cos \phi_3 = 0 \quad (7)$$

$$1.3670 A_1 \cos \phi_1 + 0.3226 A_2 \cos \phi_2 - 3.0230 A_3 \cos \phi_3 = x_{20} \quad (8)$$

$$1.3014 A_1 \cos \phi_1 - 0.6253 A_2 \cos \phi_2 + 0.5462 A_3 \cos \phi_3 = 0 \quad (9)$$

$$0.5626 \sqrt{\frac{P}{\ell m}} A_1 \sin \phi_1 + 0.9158 \sqrt{\frac{P}{\ell m}} A_2 \sin \phi_2$$

$$+ 1.5848 \sqrt{\frac{P}{\ell m}} A_3 \sin \phi_3 = 0 \quad (10)$$

$$0.5626 \sqrt{\frac{P}{\ell m}} (1.3670) A_1 \sin \phi_1 + 0.9158 \sqrt{\frac{P}{\ell m}} (0.3226) A_2 \sin \phi_2$$

$$- 1.5848 \sqrt{\frac{P}{\ell m}} (3.0230) A_3 \sin \phi_3 = 0 \quad (11)$$

$$0.5626 \sqrt{\frac{P}{\ell m}} (1.3014) A_1 \sin \phi_1 - 0.9158 \sqrt{\frac{P}{\ell m}} (0.6253) A_2 \sin \phi_2$$

$$+ 1.5848 \sqrt{\frac{P}{\ell m}} (0.5462) A_3 \sin \phi_3 = 0 \quad (12)$$

Equations (10) to (12) yield:

$$\phi_i = 0 ; i = 1, 2, 3$$

Equations (7) to (9) give

$$A_1 = 0.1527 x_{20} ; A_2 = 0.09847 x_{20} ; A_3 = -0.2512 x_{20}$$

$$x_1(t) = x_{20} (0.1527 \cos 0.5626 \sqrt{\frac{P}{\ell m}} t + 0.09847 \cos 0.9158 \sqrt{\frac{P}{\ell m}} t - 0.2512 \cos 1.5848 \sqrt{\frac{P}{\ell m}} t) \quad (13)$$

$$x_2(t) = x_{20} (0.2087 \cos 0.5626 \sqrt{\frac{P}{\ell m}} t + 0.03177 \cos 0.9158 \sqrt{\frac{P}{\ell m}} t + 0.7594 \cos 1.5848 \sqrt{\frac{P}{\ell m}} t) \quad (14)$$

$$x_3(t) = x_{20} (0.1987 \cos 0.5626 \sqrt{\frac{P}{\ell m}} t - 0.06157 \cos 0.9158 \sqrt{\frac{P}{\ell m}} t - 0.1372 \cos 1.5848 \sqrt{\frac{P}{\ell m}} t) \quad (15)$$

6.69

From solution of Problem 6.46, we obtain

$$\omega_1 = 0.3376 \sqrt{\frac{k}{m}} ; \omega_2 = 1.4142 \sqrt{\frac{k}{m}} ; \omega_3 = 2.0943 \sqrt{\frac{k}{m}}$$

$$\vec{X}^{(1)} = \begin{Bmatrix} 1 \\ 1.4430 \\ 1.6286 \end{Bmatrix} ; \vec{X}^{(2)} = \begin{Bmatrix} 1 \\ 0.5 \\ -0.5 \end{Bmatrix} ; \vec{X}^{(3)} = \begin{Bmatrix} 1 \\ -0.693 \\ 0.2047 \end{Bmatrix}$$

Initial conditions:

$$x_i(0) = 0 ; i = 1, 2, 3 ; \dot{x}_1(0) = \dot{x}_{10} , \dot{x}_2(0) = \dot{x}_3(0) = 0$$

Equations (6.98) and (6.99) can be expressed as:

$$A_1 \cos \phi_1 + A_2 \cos \phi_2 + A_3 \cos \phi_3 = 0 \quad (1)$$

$$1.4430 A_1 \cos \phi_1 + 0.5 A_2 \cos \phi_2 - 0.6930 A_3 \cos \phi_3 = 0 \quad (2)$$

$$1.6286 A_1 \cos \phi_1 - 0.5 A_2 \cos \phi_2 + 0.2047 A_3 \cos \phi_3 = 0 \quad (3)$$

$$-0.3376 \sqrt{\frac{k}{m}} A_1 \sin \phi_1 - 1.4142 \sqrt{\frac{k}{m}} A_2 \sin \phi_2 - 2.0943 \sqrt{\frac{k}{m}} A_3 \sin \phi_3 = \dot{x}_{10} \quad (4)$$

$$-0.4872 \sqrt{\frac{k}{m}} A_1 \sin \phi_1 - 0.7071 \sqrt{\frac{k}{m}} A_2 \sin \phi_2 + 1.4513 \sqrt{\frac{k}{m}} A_3 \sin \phi_3 = 0 \quad (5)$$

$$-0.5498 \sqrt{\frac{k}{m}} A_1 \sin \phi_1 + 0.7071 \sqrt{\frac{k}{m}} A_2 \sin \phi_2 - 0.4287 \sqrt{\frac{k}{m}} A_3 \sin \phi_3 = 0 \quad (6)$$

Equations (1) to (3) give:

$$\phi_i = \frac{\pi}{2} ; i = 1, 2, 3$$

Treating $\sqrt{\frac{k}{m}} A_i \sin \phi_i$ ($i = 1, 2, 3$) as unknowns and noting that all $\phi_i = \frac{\pi}{2}$, Eqs. (4) to (6) can be solved to obtain

$$\begin{aligned}\sqrt{\frac{k}{m}} A_1 &= -0.2257 \dot{x}_{10} ; A_1 = -0.2257 \sqrt{\frac{m}{k}} \dot{x}_{10} \\ \sqrt{\frac{k}{m}} A_2 &= -0.3143 \dot{x}_{10} ; A_2 = -0.3143 \sqrt{\frac{m}{k}} \dot{x}_{10} \\ \sqrt{\frac{k}{m}} A_3 &= -0.2289 \dot{x}_{10} ; A_3 = -0.2289 \sqrt{\frac{m}{k}} \dot{x}_{10}\end{aligned}$$

The free vibration solution of the system can be expressed, using Eq. (6.96), as

$$\begin{aligned}x_1(t) = \dot{x}_{10} \sqrt{\frac{m}{k}} & \left(-0.2257 \cos \left(0.3376 \sqrt{\frac{k}{m}} t + \frac{\pi}{2} \right) - 0.3143 \cos \left(1.4142 \sqrt{\frac{k}{m}} t + \frac{\pi}{2} \right) \right. \\ & \left. - 0.2289 \cos \left(2.0943 \sqrt{\frac{k}{m}} t + \frac{\pi}{2} \right) \right) \quad (7)\end{aligned}$$

$$\begin{aligned}x_2(t) = \dot{x}_{10} \sqrt{\frac{m}{k}} & \left(-0.3257 \cos \left(0.3376 \sqrt{\frac{k}{m}} t + \frac{\pi}{2} \right) - 0.1571 \cos \left(1.4142 \sqrt{\frac{k}{m}} t + \frac{\pi}{2} \right) \right. \\ & \left. + 0.1586 \cos \left(2.0943 \sqrt{\frac{k}{m}} t + \frac{\pi}{2} \right) \right) \quad (8)\end{aligned}$$

$$\begin{aligned}x_3(t) = \dot{x}_{10} \sqrt{\frac{m}{k}} & \left(-0.3676 \cos \left(0.3376 \sqrt{\frac{k}{m}} t + \frac{\pi}{2} \right) + 0.1571 \cos \left(1.4142 \sqrt{\frac{k}{m}} t + \frac{\pi}{2} \right) \right. \\ & \left. - 0.0469 \cos \left(2.0943 \sqrt{\frac{k}{m}} t + \frac{\pi}{2} \right) \right) \quad (9)\end{aligned}$$

6.70

From solution of Problem 6.54, we find:

$$\omega_1 = 0.3863 \sqrt{\frac{k}{m}} ; \omega_2 = 1.4142 \sqrt{\frac{k}{m}} ; \omega_3 = 1.8305 \sqrt{\frac{k}{m}}$$

$$\vec{X}^{(1)} = \begin{Bmatrix} 1 \\ 1.8508 \\ 2 \end{Bmatrix} ; \vec{X}^{(2)} = \begin{Bmatrix} 1 \\ 0 \\ -0.5 \end{Bmatrix} ; \vec{X}^{(3)} = \begin{Bmatrix} 1 \\ -1.3508 \\ 2 \end{Bmatrix}$$

Initial conditions:

$$x_i(0) = 0, i = 1, 2, 3 ; \dot{x}_1(0) = \dot{x}_2(0) = 0, \dot{x}_3(0) = \dot{x}_{30}$$

Equations (6.98) and (6.99) can be expressed as:

$$A_1 \cos \phi_1 + A_2 \cos \phi_2 + A_3 \cos \phi_3 = 0 \quad (1)$$

$$1.8508 A_1 \cos \phi_1 - 1.3508 A_3 \cos \phi_3 = 0 \quad (2)$$

$$2 A_1 \cos \phi_1 - 0.5 A_2 \cos \phi_2 + 2 A_3 \cos \phi_3 = 0 \quad (3)$$

$$\begin{aligned}-0.3863 \sqrt{\frac{k}{m}} A_1 \sin \phi_1 - 1.4142 \sqrt{\frac{k}{m}} A_2 \sin \phi_2 \\ - 1.8305 \sqrt{\frac{k}{m}} A_3 \sin \phi_3 = 0 \quad (4)\end{aligned}$$

$$-0.7150 \sqrt{\frac{k}{m}} A_1 \sin \phi_1 + 2.4726 \sqrt{\frac{k}{m}} A_3 \sin \phi_3 = 0 \quad (5)$$

$$\begin{aligned} -0.7726 \sqrt{\frac{k}{m}} A_1 \sin \phi_1 + 0.7071 \sqrt{\frac{k}{m}} A_2 \sin \phi_2 \\ - 3.6610 \sqrt{\frac{k}{m}} A_3 \sin \phi_3 = \dot{x}_{30} \end{aligned} \quad (6)$$

Equations (1) to (3) yield:

$$\phi_i = \frac{\pi}{2} ; i = 1, 2, 3$$

and $\sqrt{\frac{k}{m}} A_i \sin \phi_i$ ($i = 1, 2, 3$) are the unknowns in Eqs. (4) to (6). The solution of Eqs. (4) to (6) gives, with $\phi_i = \frac{\pi}{2}$:

$$\begin{aligned} \sqrt{\frac{k}{m}} A_1 &= -0.4369 \dot{x}_{30} ; A_1 = -0.4369 \dot{x}_{30} \sqrt{\frac{m}{k}} \\ \sqrt{\frac{k}{m}} A_2 &= 0.2828 \dot{x}_{30} ; A_2 = 0.2828 \dot{x}_{30} \sqrt{\frac{m}{k}} \\ \sqrt{\frac{k}{m}} A_3 &= -0.1263 \dot{x}_{30} ; A_3 = -0.1263 \dot{x}_{30} \sqrt{\frac{m}{k}} \end{aligned}$$

Thus the free vibration response of the system can be expressed as (see Eq. (6.96)):

$$\begin{aligned} x_1(t) &= \dot{x}_{30} \sqrt{\frac{m}{k}} \left(-0.4369 \cos \left(0.3863 \sqrt{\frac{k}{m}} t + \frac{\pi}{2} \right) + 0.2828 \cos \left(1.4142 \sqrt{\frac{k}{m}} t + \frac{\pi}{2} \right) \right. \\ &\quad \left. - 0.1263 \cos \left(1.8305 \sqrt{\frac{k}{m}} t + \frac{\pi}{2} \right) \right) \\ x_2(t) &= \dot{x}_{30} \sqrt{\frac{m}{k}} \left\{ -0.8086 \cos \left(0.3863 \sqrt{\frac{k}{m}} t + \frac{\pi}{2} \right) - 0.1706 \cos \left(1.8305 \sqrt{\frac{k}{m}} t + \frac{\pi}{2} \right) \right\} \\ x_3(t) &= \dot{x}_{30} \sqrt{\frac{m}{k}} \left(-0.8738 \cos \left(0.3863 \sqrt{\frac{k}{m}} t + \frac{\pi}{2} \right) - 0.1414 \cos \left(1.4142 \sqrt{\frac{k}{m}} t + \frac{\pi}{2} \right) \right. \\ &\quad \left. - 0.2526 \cos \left(1.8305 \sqrt{\frac{k}{m}} t + \frac{\pi}{2} \right) \right) \end{aligned}$$

6.71 From Example 6.13, we obtain:

$$[m] = m \begin{bmatrix} 1 & 0 & 0 \\ 0 & 1 & 0 \\ 0 & 0 & 1 \end{bmatrix} ; [k] = k \begin{bmatrix} 1 & -1 & 0 \\ -1 & 2 & -1 \\ 0 & -1 & 1 \end{bmatrix}$$

The natural frequencies and mode shapes are given by:

$$\omega_1 = 0 ; \omega_2 = \sqrt{\frac{k}{m}} ; \omega_3 = \sqrt{\frac{3k}{m}}$$

$$\vec{X}^{(1)} = a \begin{Bmatrix} 1 \\ 1 \\ 1 \end{Bmatrix}; \quad \vec{X}^{(2)} = b \begin{Bmatrix} 1 \\ 0 \\ -1 \end{Bmatrix}; \quad \vec{X}^{(3)} = c \begin{Bmatrix} 1 \\ -2 \\ 1 \end{Bmatrix}$$

Orthonormalization of mode shapes:

$$\vec{X}^{(1)T} [m] \vec{X}^{(1)} = a^2 (1 \ 1 \ 1) m \begin{bmatrix} 1 & 0 & 0 \\ 0 & 1 & 0 \\ 0 & 0 & 1 \end{bmatrix} \begin{Bmatrix} 1 \\ 1 \\ 1 \end{Bmatrix} = 3 a^2 m = 1 \quad \text{or} \quad a = \sqrt{\frac{1}{3m}}$$

$$\vec{X}^{(2)T} [m] \vec{X}^{(2)} = b^2 m (1 \ 0 \ -1) \begin{bmatrix} 1 & 0 & 0 \\ 0 & 1 & 0 \\ 0 & 0 & 1 \end{bmatrix} \begin{Bmatrix} 1 \\ 0 \\ -1 \end{Bmatrix} = 2 b^2 m = 1 \quad \text{or} \quad b = \sqrt{\frac{1}{2m}}$$

$$\vec{X}^{(3)T} [m] \vec{X}^{(3)} = c^2 m (1 \ -2 \ 1) \begin{bmatrix} 1 & 0 & 0 \\ 0 & 1 & 0 \\ 0 & 0 & 1 \end{bmatrix} \begin{Bmatrix} 1 \\ -2 \\ 1 \end{Bmatrix} = 6 c^2 m = 1 \quad \text{or} \quad c = \sqrt{\frac{1}{6m}}$$

$$\text{Modal matrix: } [X] = [\vec{X}^{(1)} \ \vec{X}^{(2)} \ \vec{X}^{(3)}] = \frac{1}{\sqrt{m}} \begin{bmatrix} \frac{1}{\sqrt{3}} & \frac{1}{\sqrt{2}} & \frac{1}{\sqrt{6}} \\ \frac{1}{\sqrt{3}} & 0 & \frac{2}{\sqrt{6}} \\ \frac{1}{\sqrt{3}} & -\frac{1}{\sqrt{2}} & \frac{1}{\sqrt{6}} \end{bmatrix} \quad (1)$$

Solution is given by Eq. (6.104):

$$\vec{x}(t) = [X] \vec{q}(t) \quad (2)$$

where $\vec{q}(t)$ is given by Eqs. (6.113):

$$\ddot{q}_i(t) + \omega_i^2 q_i(t) = Q_i(t); \quad i = 1, 2, 3 \quad (3)$$

where

$$\vec{Q}(t) = [X]^T \vec{F}(t) = \vec{0} \quad (\text{no external forces})$$

For the rigid body mode, $\omega_1^2 = 0$ and Eq. (3) reduces to:

$$\ddot{q}_1(t) = 0 \quad (4)$$

whose solution can be written as

$$q_1(t) = c_1 + c_2 t \quad (5)$$

where c_1 and c_2 are constants given by

$$c_1 = q_1(t=0); \quad c_2 = \dot{q}_1(t=0) \quad (6)$$

Initial conditions of the problem:

$$\vec{x}(0) = \begin{Bmatrix} x_1(0) \\ x_2(0) \\ x_3(0) \end{Bmatrix} = \begin{Bmatrix} 0 \\ 0 \\ 0 \end{Bmatrix} \quad (7)$$

$$\text{and } \dot{\vec{x}}(0) = \begin{Bmatrix} \dot{x}_0 \\ 0 \\ 0 \end{Bmatrix} \quad (8)$$

Using Eqs. (6.115) and (6.116), we find

$$\vec{q}(0) = [X]^T [m] \vec{x}(0) = \vec{0} \quad (9)$$

$$\dot{\vec{q}}(0) = [X]^T [m] \dot{\vec{x}}(0) = \sqrt{m} \dot{x}_0 \begin{Bmatrix} \frac{1}{\sqrt{3}} \\ \frac{1}{\sqrt{2}} \\ \frac{1}{\sqrt{6}} \end{Bmatrix} \quad (10)$$

From Eqs. (6), (9) and (10), we obtain

$$c_1 = q_1(0) = 0 \quad ; \quad c_2 = \dot{q}_1(0) = \sqrt{\frac{m}{3}} \dot{x}_0 \quad (11)$$

and hence, from Eq. (5), we find

$$q_1(t) = \sqrt{\frac{m}{3}} \dot{x}_0 t \quad (12)$$

Solution of Eqs. (3) for $q_2(t)$ and $q_3(t)$ can be expressed as

$$q_2(t) = q_2(0) \cos \omega_2 t + \frac{\dot{q}_2(0)}{\omega_2} \sin \omega_2 t = \frac{m \dot{x}_0}{\sqrt{2} k} \sin \sqrt{\frac{k}{m}} t \quad (13)$$

$$q_3(t) = q_3(0) \cos \omega_3 t + \frac{\dot{q}_3(0)}{\omega_3} \sin \omega_3 t = \frac{m \dot{x}_0}{3 \sqrt{2} k} \sin \sqrt{\frac{3k}{m}} t \quad (14)$$

The free vibration of the system is given by Eq. (2):

$$\begin{Bmatrix} x_1(t) \\ x_2(t) \\ x_3(t) \end{Bmatrix} = \frac{1}{\sqrt{m}} \begin{bmatrix} \frac{1}{\sqrt{3}} & \frac{1}{\sqrt{2}} & \frac{1}{\sqrt{6}} \\ \frac{1}{\sqrt{3}} & 0 & -\frac{2}{\sqrt{6}} \\ \frac{1}{\sqrt{3}} & -\frac{1}{\sqrt{2}} & \frac{1}{\sqrt{6}} \end{bmatrix} \begin{Bmatrix} \sqrt{\frac{m}{3}} \dot{x}_0 t \\ \frac{m \dot{x}_0}{\sqrt{2} k} \sin \sqrt{\frac{k}{m}} t \\ \frac{m \dot{x}_0}{3 \sqrt{2} k} \sin \sqrt{\frac{3k}{m}} t \end{Bmatrix} \quad (15)$$

6.72 For given system, $m = 10$, $k = 100$ and hence $\sqrt{k/m} = \sqrt{10} = 3.1623$. For free vibration response, the initial conditions lead to Eqs. (6.98) and (6.99), which can be expressed as:

$$A_1 \cos \phi_1 + A_2 \cos \phi_2 + A_3 \cos \phi_3 = x_1(0) = 0.1 \quad (1)$$

$$1.8019 A_1 \cos \phi_1 + 0.4450 A_2 \cos \phi_2 - 1.2468 A_3 \cos \phi_3 = x_2(0) = 0.1 \quad (2)$$

$$2.2470 A_1 \cos \phi_1 - 0.8020 A_2 \cos \phi_2 + 0.5544 A_3 \cos \phi_3 = x_3(0) = 0.1 \quad (3)$$

$$-0.44504 \sqrt{\frac{k}{m}} A_1 \sin \phi_1 - 1.2471 \sqrt{\frac{k}{m}} A_2 \sin \phi_2 - 1.8025 \sqrt{\frac{k}{m}} A_3 \sin \phi_3 = \dot{x}_1(0) = 0$$

or

$$-1.4073 A_1 \sin \phi_1 - 3.9437 A_2 \sin \phi_2 - 5.7000 A_3 \sin \phi_3 = 0 \quad (4)$$

$$-0.10192 \sqrt{\frac{k}{m}} A_1 \sin \phi_1 - 0.55496 \sqrt{\frac{k}{m}} A_2 \sin \phi_2 + 2.2474 \sqrt{\frac{k}{m}} A_3 \sin \phi_3 = \dot{x}_2(0) = 0$$

or

$$-0.3223 A_1 \sin \phi_1 - 1.7549 A_2 \sin \phi_2 + 7.1069 A_3 \sin \phi_3 = 0 \quad (5)$$

$$-\sqrt{\frac{k}{m}} A_1 \sin \phi_1 + \sqrt{\frac{k}{m}} A_2 \sin \phi_2 - \sqrt{\frac{k}{m}} A_3 \sin \phi_3 = \dot{x}_3(0) = 0$$

or

$$-A_1 \sin \phi_1 + A_2 \sin \phi_2 - A_3 \sin \phi_3 = 0 \quad (6)$$

Solution of Eqs. (1) to (3) is given by

$$A_1 \cos \phi_1 = 0.0543, \quad A_2 \cos \phi_2 = 0.0349, \quad A_3 \cos \phi_3 = 0.0108 \quad (7)$$

Solution of Eqs. (4) to (6) is given by

$$A_1 \sin \phi_1 = 0, \quad A_2 \sin \phi_2 = 0, \quad A_3 \sin \phi_3 = 0 \quad (8)$$

Equations (7) and (8) yield

$$\left. \begin{aligned} A_1 &= 0.0543, & A_2 &= 0.0349, & A_3 &= 0.0108 \\ \phi_1 &= 0, & \phi_2 &= 0, & \phi_3 &= 0 \end{aligned} \right\} \quad (9)$$

Thus the free vibration response of the system is given by Eq. (6.96):

$$x_1(t) = 0.0543 \cos \omega_1 t + 0.0349 \cos \omega_2 t + 0.0108 \cos \omega_3 t$$

$$x_2(t) = 1.8019(0.0543) \cos \omega_1 t + 0.4450(0.0349) \cos \omega_2 t$$

$$- 1.2468 (0.0108) \cos \omega_3 t$$

$$x_3(t) = 2.2470 (0.0543) \cos \omega_1 t - 0.8020 (0.0349) \cos \omega_2 t \\ + 0.5544 (0.0108) \cos \omega_3 t$$

$$\text{where } \omega_1 = 0.44504 \sqrt{10} = 1.4073 \text{ rad/sec, } \omega_2 = 1.2471 \sqrt{10} \\ = 3.9437 \text{ rad/sec, and } \omega_3 = 1.8025 \sqrt{10} = 5.7000 \text{ rad/sec.}$$

6.73

From the solution of Problem 5.24, the natural frequencies and normal modes are given by

$$\omega_1 = 2, \quad \vec{x}^{(1)} = \begin{Bmatrix} 1 \\ 1 \end{Bmatrix} x_1^{(1)} \quad (1)$$

$$\omega_2 = \sqrt{12}, \quad \vec{x}^{(2)} = \begin{Bmatrix} 1 \\ -1 \end{Bmatrix} x_1^{(2)} \quad (2)$$

where $x_1^{(1)}$ and $x_1^{(2)}$ are arbitrary constants. By orthogonalizing the normal modes with respect to the mass matrix, we can find the values of $x_1^{(1)}$ and $x_1^{(2)}$:

$$\vec{x}^{(1)T} [m] \vec{x}^{(1)} = 1 \Rightarrow (x_1^{(1)})^2 \{1 \ 1\} \begin{bmatrix} 2 & 0 \\ 0 & 2 \end{bmatrix} \begin{Bmatrix} 1 \\ 1 \end{Bmatrix} = 1$$

$$\text{or } x_1^{(1)} = \frac{1}{2}$$

$$\vec{x}^{(2)T} [m] \vec{x}^{(2)} = 1 \Rightarrow (x_1^{(2)})^2 \{1 \ -1\} \begin{bmatrix} 2 & 0 \\ 0 & 2 \end{bmatrix} \begin{Bmatrix} 1 \\ -1 \end{Bmatrix} = 1$$

$$\text{or } x_1^{(2)} = \frac{1}{2}$$

Thus the modal matrix becomes

$$[X] = \begin{bmatrix} \vec{x}^{(1)} & \vec{x}^{(2)} \end{bmatrix} = \frac{1}{2} \begin{bmatrix} 1 & 1 \\ 1 & -1 \end{bmatrix} \quad (3)$$

Using $\vec{x} = [X] \vec{q}$, the equations of motion can be written as

$$\ddot{\vec{q}} + [\omega^2] \vec{q} = \vec{Q} = \vec{0} \quad (4)$$

$$\text{or } \ddot{q}_i + \omega_i^2 q_i = 0; \quad i = 1, 2 \quad (5)$$

Solution of Eqs. (5):

$$q_i(t) = q_{i0} \cos \omega_i t + \frac{\dot{q}_{i0}}{\omega_i} \sin \omega_i t \quad (6)$$

where q_{i0} and \dot{q}_{i0} denote the initial values of q_i

and \dot{q}_i , respectively. From given initial conditions, we find:

$$\vec{q}(0) = \begin{Bmatrix} q_{10}(0) \\ q_{20}(0) \end{Bmatrix} = [X]^T [m] \vec{x}(0) = \frac{1}{2} \begin{bmatrix} 1 & 1 \\ 1 & -1 \end{bmatrix} \begin{bmatrix} 2 & 0 \\ 0 & 2 \end{bmatrix} \begin{Bmatrix} 1 \\ 0 \end{Bmatrix} \\ = \begin{Bmatrix} 1 \\ 1 \end{Bmatrix}$$

$$\dot{\vec{q}}(0) = \begin{Bmatrix} \dot{q}_{10}(0) \\ \dot{q}_{20}(0) \end{Bmatrix} = [X]^T [m] \dot{\vec{x}}(0) = \frac{1}{2} \begin{bmatrix} 1 & 1 \\ 1 & -1 \end{bmatrix} \begin{bmatrix} 2 & 0 \\ 0 & 2 \end{bmatrix} \begin{Bmatrix} 0 \\ 1 \end{Bmatrix} \\ = \begin{Bmatrix} 1 \\ -1 \end{Bmatrix}$$

Thus Eqs. (6) become

$$q_1(t) = \cos 2t + \frac{1}{2} \sin 2t$$

$$q_2(t) = \cos \sqrt{12} t - \frac{1}{\sqrt{12}} \sin \sqrt{12} t$$

The physical displacements can be found as

$$\vec{x}(t) = [X] \vec{q}(t) = \frac{1}{2} \begin{bmatrix} 1 & 1 \\ 1 & -1 \end{bmatrix} \begin{Bmatrix} q_1 \\ q_2 \end{Bmatrix}$$

or

$$x_1(t) = \frac{1}{2} (q_1 + q_2), \quad x_2(t) = \frac{1}{2} (q_1 - q_2)$$

$$\therefore x_1(t) = \frac{1}{2} \left[\cos 2t + \frac{1}{2} \sin 2t + \cos \sqrt{12} t - \frac{1}{\sqrt{12}} \sin \sqrt{12} t \right]$$

$$x_2(t) = \frac{1}{2} \left[\cos 2t + \frac{1}{2} \sin 2t - \cos \sqrt{12} t + \frac{1}{\sqrt{12}} \sin \sqrt{12} t \right]$$

6.74

Equations of motion are

$$\begin{bmatrix} 2m & 0 & 0 \\ 0 & m & 0 \\ 0 & 0 & m \end{bmatrix} \begin{Bmatrix} \ddot{x}_1 \\ \ddot{x}_2 \\ \ddot{x}_3 \end{Bmatrix} + \begin{bmatrix} 3k & -k & -k \\ -k & k & 0 \\ -k & 0 & k \end{bmatrix} \begin{Bmatrix} x_1 \\ x_2 \\ x_3 \end{Bmatrix} = \begin{Bmatrix} 0 \\ 0 \\ F(t) \end{Bmatrix}$$

where $m = 1 \text{ kg}$, $k = 1000 \text{ N/m}$, $F(t) = 5 \sin 10t \text{ N}$.

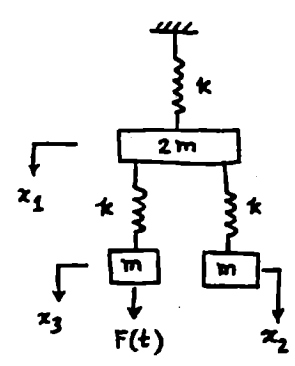

Eigenvalue analysis:

Frequency equation is

$$\left| -\omega^2 m \begin{bmatrix} 2 & 0 & 0 \\ 0 & 1 & 0 \\ 0 & 0 & 1 \end{bmatrix} + k \begin{bmatrix} 3 & -1 & -1 \\ -1 & 1 & 0 \\ -1 & 0 & 1 \end{bmatrix} \right| = 0$$

or
$$\begin{vmatrix} -2\lambda + 3 & -1 & -1 \\ -1 & -\lambda + 1 & 0 \\ -1 & 0 & -\lambda + 1 \end{vmatrix} = 0 \quad \text{where } \lambda = \frac{\omega^2 m}{k}$$

or
$$2\lambda^3 - 7\lambda^2 + 6\lambda - 1 = 0$$

Roots are

$\lambda_1 = 0.219220, \quad \lambda_2 = 1.0, \quad \lambda_3 = 2.28078$
 $\omega_1 = 0.4682094 \sqrt{\frac{k}{m}}, \quad \omega_2 = 1.0 \sqrt{\frac{k}{m}}, \quad \omega_3 = 1.5102251 \sqrt{\frac{k}{m}}$

Mode shapes are given by

$$\begin{bmatrix} -2\lambda_i + 3 & -1 & -1 \\ -1 & -\lambda_i + 1 & 0 \\ -1 & 0 & -\lambda_i + 1 \end{bmatrix} \begin{Bmatrix} x_1^{(i)} \\ x_2^{(i)} \\ x_3^{(i)} \end{Bmatrix} = \begin{Bmatrix} 0 \\ 0 \\ 0 \end{Bmatrix}$$

or
$$x_1^{(i)} = (-\lambda_i + 1) x_2^{(i)}, \quad x_3^{(i)} = (-2\lambda_i + 3) x_1^{(i)} - x_2^{(i)}$$

$$\vec{x}^{(i)} = \begin{Bmatrix} -\lambda_i + 1 \\ 1 \\ (-2\lambda_i + 3)(-\lambda_i + 1) - 1 \end{Bmatrix} x_2^{(i)}$$

$\vec{x}^{(1)} = \begin{Bmatrix} 0.78078 \\ 1 \\ 1 \end{Bmatrix} x_2^{(1)}, \quad \vec{x}^{(2)} = \begin{Bmatrix} 0 \\ 1 \\ -1 \end{Bmatrix} x_2^{(2)}, \quad \vec{x}^{(3)} = \begin{Bmatrix} -1.28078 \\ 1 \\ 1 \end{Bmatrix} x_2^{(3)}$

Normalization of mode shapes with respect to $[m]$:

$$\vec{x}^{(1)T} [m] \vec{x}^{(1)} = (0.78078 \quad 1 \quad 1) \begin{Bmatrix} 1.56156 \\ 1 \\ 1 \end{Bmatrix} (x_2^{(1)})^2 = 3.21923 (x_2^{(1)})^2 = 1$$

$$x_2^{(1)} = 0.55734; \quad \vec{x}^{(1)} = \begin{Bmatrix} 0.43516 \\ 0.55734 \\ 0.55734 \end{Bmatrix}$$

$$\vec{x}^{(2)T} [m] \vec{x}^{(2)} = (0 \quad 1 \quad -1) \begin{Bmatrix} 0 \\ 1 \\ -1 \end{Bmatrix} (x_2^{(2)})^2 = 2 (x_2^{(2)})^2 = 1$$

$$x_2^{(2)} = 0.70711; \quad \vec{x}^{(2)} = \begin{Bmatrix} 0 \\ 0.70711 \\ -0.70711 \end{Bmatrix}$$

$$\vec{x}^{(3)T} [m] \vec{x}^{(3)} = (-1.28078 \quad 1 \quad 1) \begin{Bmatrix} -2.56156 \\ 1 \\ 1 \end{Bmatrix} (x_2^{(3)})^2 = 5.28079 (x_2^{(3)})^2 = 1$$

$$x_2^{(3)} = 0.43516; \quad \vec{x}^{(3)} = \begin{Bmatrix} -0.55734 \\ 0.43516 \\ 0.43516 \end{Bmatrix}$$

$\vec{Q} = [X]^T \vec{F}(t) =$ vector of generalized forces

$$= \begin{bmatrix} 0.43516 & 0.55734 & 0.55734 \\ 0 & 0.70711 & -0.70711 \\ -0.55734 & 0.43516 & 0.43516 \end{bmatrix} \begin{Bmatrix} 0 \\ 0 \\ F_0 \sin \omega t \end{Bmatrix} = \begin{Bmatrix} 2.7867 \\ -3.5356 \\ 2.1758 \end{Bmatrix} \sin 10t$$

Uncoupled equations of motion are

$$\left. \begin{aligned} \ddot{v}_1 + 219.22 v_1 &= 2.7867 \sin 10t \\ \ddot{v}_2 + 1000.00 v_2 &= -3.5356 \sin 10t \\ \ddot{v}_3 + 2280.78 v_3 &= 2.1758 \sin 10t \end{aligned} \right\} \quad (E.1)$$

Particular solutions of (E.1) are

$$v_1(t) = \left(\frac{2.7867}{219.22 - 100} \right) \sin 10t = 0.0233744 \sin 10t$$

$$v_2(t) = \left(\frac{-3.5356}{1000 - 100} \right) \sin 10t = -0.0039284 \sin 10t$$

$$v_3(t) = \left(\frac{2.1758}{2280.78 - 100} \right) \sin 10t = 0.0009977 \sin 10t$$

Since $\vec{x} = [X] \vec{v} = \begin{bmatrix} 0.43516 & 0 & -0.55734 \\ 0.55734 & 0.70711 & 0.43516 \\ 0.55734 & -0.70711 & 0.43516 \end{bmatrix} \vec{v}$, we get

$$x_1(t) = 0.0096155 \sin 10t \quad m$$

$$x_2(t) = 0.0095333 \sin 10t \quad m$$

$$x_3(t) = 0.0162395 \sin 10t \quad m.$$

6.75 (a) From Example 6.8, for $k_{t1} = k_{t2} = k_{t3} = k_t$ and $J_1 = J_2 = J_3 = J_0$,

$$[m] = J_0 \begin{bmatrix} 1 & 0 & 0 \\ 0 & 1 & 0 \\ 0 & 0 & 1 \end{bmatrix}, \quad [k] = k_t \begin{bmatrix} 2 & -1 & 0 \\ -1 & 2 & -1 \\ 0 & -1 & 1 \end{bmatrix}$$

Eigenvalue problem becomes

$$\begin{bmatrix} -\lambda + 2 & -1 & 0 \\ -1 & -\lambda + 2 & -1 \\ 0 & -1 & -\lambda + 1 \end{bmatrix} \begin{Bmatrix} \Theta_1 \\ \Theta_2 \\ \Theta_3 \end{Bmatrix} = \begin{Bmatrix} 0 \\ 0 \\ 0 \end{Bmatrix} \quad \text{where } \lambda = \frac{\omega^2 J_0}{k_t} \quad \text{--- (E.1)}$$

Frequency equation is

$$\lambda^3 - 5\lambda^2 + 6\lambda - 1 = 0$$

Roots are

$$\lambda_1 = 0.198, \quad \lambda_2 = 1.555, \quad \lambda_3 = 3.247$$

$$\omega_1 = 0.44497 \sqrt{\frac{k_t}{J_0}}, \quad \omega_2 = 1.24700 \sqrt{\frac{k_t}{J_0}}, \quad \omega_3 = 1.80194 \sqrt{\frac{k_t}{J_0}}$$

(E.1) gives $\Theta_2^{(j)} = (-\lambda_j + 2) \Theta_1^{(j)}, \quad \Theta_3^{(j)} = \left(\frac{-\lambda_j + 2}{-\lambda_j + 1} \right) \Theta_1^{(j)}$

$$\vec{\Theta}^{(j)} = \begin{Bmatrix} 1 \\ -\lambda_j + 2 \\ \left(\frac{-\lambda_j + 2}{-\lambda_j + 1} \right) \end{Bmatrix} \Theta_1^{(j)}$$

$$\vec{\Theta}^{(1)} = \begin{Bmatrix} 1 \\ 1.802 \\ 2.247 \end{Bmatrix} \Theta_1^{(1)}, \quad \vec{\Theta}^{(2)} = \begin{Bmatrix} 1 \\ 0.445 \\ -0.802 \end{Bmatrix} \Theta_1^{(2)}, \quad \vec{\Theta}^{(3)} = \begin{Bmatrix} 1 \\ -1.247 \\ 0.555 \end{Bmatrix} \Theta_1^{(3)}$$

Normalization:

$$\vec{\Theta}^{(1)T} [m] \vec{\Theta}^{(1)} = (1 \quad 1.802 \quad 2.247) \begin{Bmatrix} 1 \\ 1.802 \\ 2.247 \end{Bmatrix} J_0 \left(\Theta_1^{(1)} \right)^2 = 9.2962 \left(\Theta_1^{(1)} \right)^2 J_0 = 1$$

$$\Theta_1^{(1)} = 0.328 / \sqrt{J_0}$$

$$\vec{\Theta}^{(2)T} [m] \vec{\Theta}^{(2)} = (1 \quad 0.445 \quad -0.802) \begin{Bmatrix} 1 \\ 0.445 \\ -0.802 \end{Bmatrix} J_0 \left(\Theta_1^{(2)} \right)^2 = 1.8412 \left(\Theta_1^{(2)} \right)^2 J_0 = 1$$

$$\Theta_1^{(2)} = 0.737 / \sqrt{J_0}$$

$$\vec{\Theta}^{(3)T} [m] \vec{\Theta}^{(3)} = (1 \quad -1.247 \quad 0.555) \begin{Bmatrix} 1 \\ -1.247 \\ 0.555 \end{Bmatrix} J_0 \left(\Theta_1^{(3)} \right)^2 = 2.863 \left(\Theta_1^{(3)} \right)^2 J_0 = 1$$

$$\Theta_1^{(3)} = 0.591 / \sqrt{J_0}$$

[m]- orthonormal modal matrix is

$$[X] = \frac{1}{\sqrt{J_0}} \begin{bmatrix} 0.328 & 0.737 & 0.591 \\ 0.591 & 0.328 & -0.737 \\ 0.737 & -0.591 & 0.328 \end{bmatrix}$$

For given data,

$$\omega_1 = 4.4497 \text{ rad/s}, \quad \omega_2 = 12.4700 \text{ rad/s}, \quad \omega_3 = 18.0194 \text{ rad/s}$$

$$[X] = \begin{bmatrix} 0.328 & 0.737 & 0.591 \\ 0.591 & 0.328 & -0.737 \\ 0.737 & -0.591 & 0.328 \end{bmatrix}$$

(b) According to modal analysis, uncoupled equations of motion are

$$\ddot{z}_i(t) + \omega_i^2 z_i(t) = Q_i(t); \quad i = 1, 2, 3 \quad (\text{E.2})$$

where $\vec{Q}(t) = [X]^T \vec{M}_t(t) = [X]^T \begin{Bmatrix} 0 \\ 0 \\ m_{t0} \cos \omega t \end{Bmatrix}$
 $= \begin{Bmatrix} Q_{10} \\ Q_{20} \\ Q_{30} \end{Bmatrix} \cos 100 t \equiv \begin{Bmatrix} 368.5 \\ -295.5 \\ 164.0 \end{Bmatrix} \cos 100 t$

Steady state solution of (E-2) is $\varrho_i(t) = \left(\frac{Q_{i0}}{\omega_i^2 - \omega^2} \right) \cos \omega t$

$\therefore \varrho_1(t) = -0.03692 \cos 100 t$
 $\varrho_2(t) = 0.03002 \cos 100 t$
 $\varrho_3(t) = -0.01695 \cos 100 t$

Angular deflections are

$\vec{\Theta}(t) = [X] \vec{\varrho}(t) = \begin{Bmatrix} -0.0000025 \\ 0.0005190 \\ -0.0505115 \end{Bmatrix} \cos 100 t \text{ radian}$

6.76 From problem 6.51, $\vec{X}^{(1)} = \begin{Bmatrix} 1 \\ \sqrt{2} \\ 1 \end{Bmatrix} X_1^{(1)}$, $\vec{X}^{(2)} = \begin{Bmatrix} 1 \\ 0 \\ -1 \end{Bmatrix} X_1^{(2)}$, $\vec{X}^{(3)} = \begin{Bmatrix} 1 \\ -\sqrt{2} \\ 1 \end{Bmatrix} X_1^{(3)}$

$[m] = m \begin{bmatrix} 1 & 0 & 0 \\ 0 & 1 & 0 \\ 0 & 0 & 1 \end{bmatrix}$

Normalization gives

$\vec{X}^{(1)T} [m] \vec{X}^{(1)} = (1 \ \sqrt{2} \ 1) \begin{Bmatrix} 1 \\ \sqrt{2} \\ 1 \end{Bmatrix} (X_1^{(1)})^2 m = 1 \Rightarrow X_1^{(1)} = \frac{1}{2\sqrt{m}}$

$\vec{X}^{(2)T} [m] \vec{X}^{(2)} = (1 \ 0 \ -1) \begin{Bmatrix} 1 \\ 0 \\ -1 \end{Bmatrix} (X_1^{(2)})^2 m = 1 \Rightarrow X_1^{(2)} = \frac{1}{\sqrt{2m}}$

$\vec{X}^{(3)T} [m] \vec{X}^{(3)} = (1 \ -\sqrt{2} \ 1) \begin{Bmatrix} 1 \\ -\sqrt{2} \\ 1 \end{Bmatrix} (X_1^{(3)})^2 m = 1 \Rightarrow X_1^{(3)} = \frac{1}{2\sqrt{m}}$

Modal matrix is

$[X] = \frac{1}{\sqrt{m}} \begin{bmatrix} 1/2 & 1/\sqrt{2} & 1/2 \\ 1/\sqrt{2} & 0 & -1/\sqrt{2} \\ 1/2 & -1/\sqrt{2} & 1/2 \end{bmatrix}$

original coupled equations are $[m] \ddot{\vec{x}} + [k] \vec{x} = \vec{0}$

uncoupled equations with $\vec{x} = [X] \vec{\varrho}$ are

$\ddot{\vec{\varrho}} + [\omega^2] \vec{\varrho} = \vec{0}$

or $\begin{Bmatrix} \ddot{\varrho}_1 \\ \ddot{\varrho}_2 \\ \ddot{\varrho}_3 \end{Bmatrix} + \begin{bmatrix} \omega_1^2 & 0 & 0 \\ 0 & \omega_2^2 & 0 \\ 0 & 0 & \omega_3^2 \end{bmatrix} \begin{Bmatrix} \varrho_1 \\ \varrho_2 \\ \varrho_3 \end{Bmatrix} = \begin{Bmatrix} 0 \\ 0 \\ 0 \end{Bmatrix}$

with $\omega_1^2 = 0.585786 \frac{k}{m}$, $\omega_2^2 = 2 \frac{k}{m}$, $\omega_3^2 = 3.414214 \frac{k}{m}$.

$$(6.77) [k]^{-1} \vec{F}(t) = \frac{1}{k} \begin{bmatrix} 1 & 1 & 1 \\ 1 & 2 & 2 \\ 1 & 2 & 3 \end{bmatrix} \begin{Bmatrix} 1 \\ 1 \\ 1 \end{Bmatrix} F_0 \cos \omega t = \frac{1}{k} \begin{Bmatrix} 3 \\ 5 \\ 6 \end{Bmatrix} F_0 \cos \omega t$$

From Example 6.18,

$$\begin{aligned} \rho_{10} &= \frac{q_{10}}{\omega_1^2} \frac{1}{\left|1 - \left(\frac{\omega}{\omega_1}\right)^2\right|} = \frac{1.6561 \frac{F_0}{\sqrt{m}}}{\left(0.19806 \frac{k}{m}\right)} * \frac{1}{\left|1 - \left(\frac{1.75}{0.44504}\right)^2\right|} \\ &= 0.57816 F_0 \sqrt{m}/k \end{aligned}$$

$$\text{and } \rho_1(t) = \rho_{10} \cos \omega t ; \quad \ddot{\rho}_1 = -\rho_{10} \omega^2 \cos \omega t$$

$$\begin{aligned} -\frac{1}{\omega_1^2} \vec{X}^{(1)} \ddot{\rho}_1(t) &= \rho_{10} \left(\frac{\omega^2}{\omega_1^2}\right) \frac{1}{\sqrt{m}} \begin{Bmatrix} 0.3280 \\ 0.5911 \\ 0.7370 \end{Bmatrix} \cos \omega t \\ &= 8.93979 \frac{F_0}{k} \begin{Bmatrix} 0.3280 \\ 0.5911 \\ 0.7370 \end{Bmatrix} \cos \omega t \end{aligned}$$

Eq. (E.3) in problem statement gives

$$\begin{aligned} \vec{x}(t) &= \begin{Bmatrix} 3 \\ 5 \\ 6 \end{Bmatrix} \frac{F_0}{k} \cos \omega t + \begin{Bmatrix} 2.93225 \\ 5.28431 \\ 6.58863 \end{Bmatrix} \frac{F_0}{k} \cos \omega t \\ &= \begin{Bmatrix} 5.93225 \\ 10.28431 \\ 12.58863 \end{Bmatrix} \frac{F_0}{k} \cos \omega t \end{aligned}$$

(6.78) Equations of motion for free vibration

$$m \begin{bmatrix} 1 & 0 & 0 \\ 0 & 2 & 0 \\ 0 & 0 & 3 \end{bmatrix} \ddot{\vec{x}} + k \begin{bmatrix} 3 & -2 & 0 \\ -2 & 5 & -3 \\ 0 & -3 & 3 \end{bmatrix} \vec{x} = \begin{Bmatrix} 0 \\ 0 \\ 0 \end{Bmatrix}$$

From problem 6.46,

$$\omega_1 = 0.337627, \quad \omega_2 = 1.414221, \quad \omega_3 = 2.094278$$

$$\vec{X}^{(1)} = \begin{Bmatrix} 1.0 \\ 1.443004 \\ 1.628659 \end{Bmatrix} X_1^{(1)}, \quad \vec{X}^{(2)} = \begin{Bmatrix} 1.0 \\ 0.49999 \\ -0.49998 \end{Bmatrix} X_1^{(2)}, \quad \vec{X}^{(3)} = \begin{Bmatrix} 1.0 \\ -0.693 \\ 0.204666 \end{Bmatrix} X_1^{(3)}$$

Free vibratory motion is given by (see section 5.3)

$$\begin{aligned} \vec{x}(t) &= \vec{x}^{(1)}(t) + \vec{x}^{(2)}(t) + \vec{x}^{(3)}(t) \\ &= \left\{ \begin{aligned} &X_1^{(1)} \cos(\omega_1 t + \phi_1) + X_1^{(2)} \cos(\omega_2 t + \phi_2) + X_1^{(3)} \cos(\omega_3 t + \phi_3) \\ &1.443 X_1^{(1)} \cos(\omega_1 t + \phi_1) + 0.5 X_1^{(2)} \cos(\omega_2 t + \phi_2) - 0.693 X_1^{(3)} \cos(\omega_3 t + \phi_3) \\ &1.6287 X_1^{(1)} \cos(\omega_1 t + \phi_1) - 0.5 X_1^{(2)} \cos(\omega_2 t + \phi_2) + 0.2047 X_1^{(3)} \cos(\omega_3 t + \phi_3) \end{aligned} \right\} \end{aligned}$$

known initial conditions give

--- (E.1)

$$\begin{Bmatrix} x_1(0) \\ x_2(0) \\ x_3(0) \end{Bmatrix} = \begin{Bmatrix} 1 \\ 2 \\ 1 \end{Bmatrix} = \begin{bmatrix} 1 & 1 & 1 \\ 1.443 & 0.5 & -0.693 \\ 1.6287 & -0.5 & 0.2047 \end{bmatrix} \begin{Bmatrix} X_1^{(1)} \cos \phi_1 \\ X_1^{(2)} \cos \phi_2 \\ X_1^{(3)} \cos \phi_3 \end{Bmatrix} \quad \text{--- (E.2)}$$

$$\begin{Bmatrix} \dot{x}_1(0) \\ \dot{x}_2(0) \\ \dot{x}_3(0) \end{Bmatrix} = \begin{Bmatrix} 0 \\ 1 \\ -1 \end{Bmatrix} = \begin{bmatrix} -\omega_1 & -\omega_2 & -\omega_3 \\ -1.443 \omega_1 & -0.5 \omega_2 & 0.693 \omega_3 \\ -1.6287 \omega_1 & 0.5 \omega_2 & -0.2047 \omega_3 \end{bmatrix} \begin{Bmatrix} X_1^{(1)} \sin \phi_1 \\ X_1^{(2)} \sin \phi_2 \\ X_1^{(3)} \sin \phi_3 \end{Bmatrix} \quad \text{--- (E.3)}$$

Solution of (E.2) and (E.3) gives

$$X_1^{(1)} \cos \phi_1 = 0.8884, \quad X_1^{(1)} \sin \phi_1 = 0.4514$$

$$X_1^{(2)} \cos \phi_2 = 0.6667, \quad X_1^{(2)} \sin \phi_2 = -0.7857$$

$$X_1^{(3)} \cos \phi_3 = -0.5551, \quad X_1^{(3)} \sin \phi_3 = 0.4578$$

Hence $X_1^{(1)} = 0.9965$, $X_1^{(2)} = 1.0304$, $X_1^{(3)} = 0.7195$

$$\phi_1 = 26.9353^\circ, \quad \phi_2 = -49.6840^\circ, \quad \phi_3 = 140.4870^\circ$$

and the final solution is given by (E.1).

6.79

$$\vec{x}(t) = [X] \vec{q}(t); \quad \dot{\vec{x}}(t) = [X] \dot{\vec{q}}(t) \quad (1)$$

If $\vec{x}(0)$ and $\dot{\vec{x}}(0)$ are the known initial conditions in terms of physical coordinates, to find the corresponding values of $\vec{q}(0)$ and $\dot{\vec{q}}(0)$, we premultiply both sides of Eq. (1) by $[X]^T [m]$ to obtain at $t = 0$:

$$[X]^T [m] \vec{x}(0) = [X]^T [m] [X] \vec{q}(0) \quad (2)$$

$$[X]^T [m] \dot{\vec{x}}(0) = [X]^T [m] [X] \dot{\vec{q}}(0) \quad (3)$$

Since the normal modes are normalized with respect to the mass matrix as

$$[X]^T [m] [X] = [I] \quad (4)$$

Eqs. (2) and (3) reduce to:

$$\vec{q}(0) = [X]^T [m] \vec{x}(0); \quad \dot{\vec{q}}(0) = [X]^T [m] \dot{\vec{x}}(0) \quad (5)$$

6.80

$$[k] = \begin{bmatrix} 150 & -100 \\ -100 & 100 \end{bmatrix} (10^3) \text{ N/m}$$

$$[m] = \begin{bmatrix} 40 & 0 \\ 0 & 80 \end{bmatrix} \text{ kg}$$

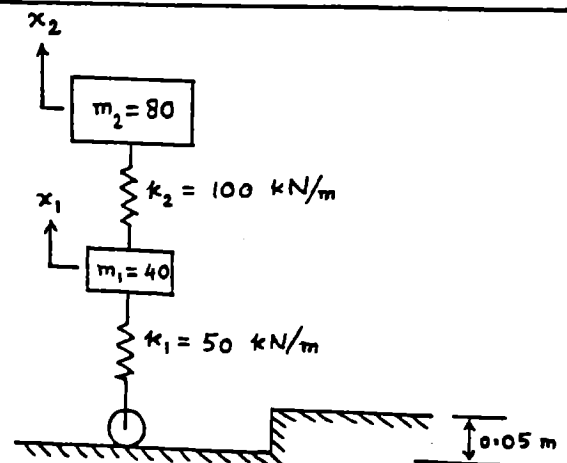

Natural frequencies are given by (see Eq. (3) in the solution of Problem 5.1):

$$\begin{aligned}\omega_{1,2}^2 &= \frac{k_1 + k_2}{2 m_1} + \frac{k_2}{2 m_2} \pm \left\{ \frac{1}{4} \left(\frac{k_1 + k_2}{m_1} + \frac{k_2}{m_2} \right)^2 - \frac{k_1 k_2}{m_1 m_2} \right\}^{\frac{1}{2}} \\ &= \left[\frac{150}{80} + \frac{100}{160} \pm \left\{ \frac{1}{4} \left(\frac{150}{40} + \frac{100}{80} \right)^2 - \frac{(100)(50)}{(40)(80)} \right\}^{\frac{1}{2}} \right] (10^3) \\ &= 334.9365, 4665.1\end{aligned}$$

$$\omega_1 = 18.3013 \text{ rad/sec} ; \omega_2 = 68.3015 \text{ rad/sec}$$

Mode shapes are defined by Eqs. (4) and (5) in the solution of Problem 5.1:

$$\begin{aligned}\frac{X_2^{(1)}}{X_1^{(1)}} &= \frac{k_2}{-m_2 \omega_1^2 + k_2} = \frac{100 (10^3)}{-(80) (334.9365)^2 + (100) (10^3)} = 1.3660 \\ \vec{X}^{(1)} &= a \begin{Bmatrix} 1.0 \\ 1.366 \end{Bmatrix}\end{aligned}$$

where a is a constant.

$$\begin{aligned}\frac{X_2^{(2)}}{X_1^{(2)}} &= \frac{k_2}{-m_2 \omega_2^2 + k_2} = \frac{(100) (10^3)}{-(80) (4665.1)^2 + (100) (10^3)} = -0.3660 \\ \vec{X}^{(2)} &= b \begin{Bmatrix} 1.0 \\ -0.366 \end{Bmatrix}\end{aligned}$$

where b is a constant.

Orthogonalization of modes:

$$\vec{X}^{(1)T} [m] \vec{X}^{(1)} = a^2 (1.0 \quad 1.366) \begin{bmatrix} 40 & 0 \\ 0 & 80 \end{bmatrix} \begin{Bmatrix} 1.0 \\ 1.366 \end{Bmatrix} = 189.2765 a^2 = 1$$

$$a = 0.07269$$

$$\vec{X}^{(2)T} [m] \vec{X}^{(2)} = b^2 (1.0 \quad -0.366) \begin{bmatrix} 40 & 0 \\ 0 & 80 \end{bmatrix} \begin{Bmatrix} 1.0 \\ -0.366 \end{Bmatrix} = 50.7165 b^2 = 1$$

$$b = 0.14042$$

Modal matrix:

$$[X] = \begin{bmatrix} 0.07269 & 0.14042 \\ 0.09929 & -0.05139 \end{bmatrix}$$

Due to the elevation of 0.05 m, spring k_1 and hence m_1 will be subjected to additional compression of $k_1 (0.05) = 2500$ N.

$$\vec{F}(t) = \begin{Bmatrix} 2500 \\ 0 \end{Bmatrix} \text{ N}$$

Equation (6.111) gives:

$$\vec{Q}(t) = [X]^T \vec{F}(t) = \begin{Bmatrix} 181.725 \\ 351.05 \end{Bmatrix}$$

Solution is given by (without initial conditions) Eq. (6.114):

$$q_i(t) = \frac{1}{\omega_i} \int_0^t Q_i(\tau) \sin \omega_i (t - \tau) d\tau ; i = 1, 2$$

$$\text{Since } \int_{\tau=0}^t \sin \Omega (t - \tau) d\tau = - \int_{\tau'=t-\tau=0}^{\tau'=t-\tau=t} \sin \Omega \tau' d\tau' = \frac{1}{\Omega} (1 - \cos \Omega t)$$

we find

$$q_1(t) = \frac{181.725}{(18.3013^2)} (1 - \cos 18.3013 t) = 0.5426 (1 - \cos 18.3013 t)$$

$$q_2(t) = \frac{351.05}{(68.3015^2)} (1 - \cos 68.3015 t) = 0.07525 (1 - \cos 68.3015 t)$$

Response of the masses can be found from Eq. (6.104):

$$\vec{x}(t) = [X] \vec{q}(t) = \begin{bmatrix} 0.07269 & 0.14042 \\ 0.09929 & -0.05139 \end{bmatrix} \begin{Bmatrix} 0.5426 (1 - \cos 18.3013 t) \\ 0.07525 (1 - \cos 68.3015 t) \end{Bmatrix}$$

$$= \begin{Bmatrix} 0.03944 (1 - \cos 18.3013 t) + 0.01057 (1 - \cos 68.3015 t) \\ 0.05387 (1 - \cos 18.3013 t) - 0.00387 (1 - \cos 68.3015 t) \end{Bmatrix}$$

Note:

This problem can also be solved by specifying the initial conditions as

$$\vec{x}(0) = \begin{Bmatrix} 0.05 \\ 0.05 \end{Bmatrix} \text{ m} ; \quad \dot{\vec{x}}(0) = \begin{Bmatrix} 0 \\ 0 \end{Bmatrix}$$

and solving the free vibration problem.

6.81 $\ell_i = 0.5$ m ; $m_i = 1$ kg ($i = 1, 2, 3$). Assume $m_1 = m_2 = m_3 = m = 1$; $\ell_1 = \ell_2 = \ell_3 = \ell = 0.5$.

From solution of Problem 6.37, we obtain:

$$[m] = m \ell^2 \begin{bmatrix} 3 & 2 & 1 \\ 2 & 2 & 1 \\ 1 & 1 & 1 \end{bmatrix} = 0.25 \begin{bmatrix} 3 & 2 & 1 \\ 2 & 2 & 1 \\ 1 & 1 & 1 \end{bmatrix}$$

$$[k] = m g \ell \begin{bmatrix} 3 & 0 & 0 \\ 0 & 2 & 0 \\ 0 & 0 & 1 \end{bmatrix} = 4.905 \begin{bmatrix} 3 & 0 & 0 \\ 0 & 2 & 0 \\ 0 & 0 & 1 \end{bmatrix}$$

From solution of Problem 6.53, the natural frequencies and mode shapes can be found as

$$\omega_1 = 0.644798 \sqrt{\frac{g}{\ell}} ; \omega_2 = 1.514698 \sqrt{\frac{g}{\ell}} ; \omega_3 = 2.507977 \sqrt{\frac{g}{\ell}}$$

Since $\sqrt{\frac{g}{\ell}} = \sqrt{\frac{9.81}{0.5}} = 4.4294$, we find

$$\omega_1 = 2.8561 \text{ rad/sec} ; \omega_2 = 6.7092 \text{ rad/sec} ; \omega_3 = 11.1088 \text{ rad/sec}$$

$$\vec{X}^{(1)} = a \begin{bmatrix} 1.0 \\ 1.2922 \\ 1.6312 \end{bmatrix} ; \vec{X}^{(2)} = b \begin{bmatrix} 1.0 \\ 0.3527 \\ -2.3978 \end{bmatrix} ; \vec{X}^{(3)} = c \begin{bmatrix} 1.0 \\ -1.6450 \\ 0.7669 \end{bmatrix}$$

Orthonormalization of mode shapes:

$$\begin{aligned} \vec{X}^{(1)\top} [\mathbf{m}] \vec{X}^{(1)} &= 5.4118 a^2 = 1 \quad \text{or} \quad a = 0.4299 \\ \vec{X}^{(2)\top} [\mathbf{m}] \vec{X}^{(2)} &= 0.9805 b^2 = 1 \quad \text{or} \quad b = 1.0099 \\ \vec{X}^{(3)\top} [\mathbf{m}] \vec{X}^{(3)} &= 0.3577 c^2 = 1 \quad \text{or} \quad c = 1.6720 \end{aligned}$$

Modal matrix:

$$[\mathbf{X}] = \begin{bmatrix} \vec{X}^{(1)} & \vec{X}^{(2)} & \vec{X}^{(3)} \end{bmatrix} = \begin{bmatrix} 0.4299 & 1.0099 & 1.6720 \\ 0.5555 & 0.3562 & -2.7504 \\ 0.7012 & -2.4215 & 1.2822 \end{bmatrix} \quad (1)$$

$$\vec{F}(t) = \begin{bmatrix} 0 \\ 0 \\ M_{t3}(t) \end{bmatrix} \quad (2)$$

$$\vec{Q}(t) = [\mathbf{X}]^T \vec{F}(t) = \begin{bmatrix} 0.7012 M_{t3}(t) \\ -2.4215 M_{t3}(t) \\ 1.2822 M_{t3}(t) \end{bmatrix} \quad (3)$$

Solution of $q_i(t)$ without initial conditions:

$$q_i(t) = \frac{1}{\omega_i} \int_0^t Q_i(\tau) \sin \omega_i (t - \tau) d\tau ; \quad i = 1, 2, 3 \quad (4)$$

We denote $M_{t3}(t)$ as

$$M_{t3}(t) = M_0 \left(u(t) - u(t - t_0) \right) \quad (5)$$

where $M_0 = 0.1 \text{ N-m}$, $t_0 = 0.1 \text{ sec}$ and $u(t)$ and $u(t - t_0)$ are the unit step functions:

$$u(t) = \begin{cases} 0 & ; t < 0 \\ 1 & ; t > 0 \end{cases}$$

$$u(t - t_0) = \begin{cases} 0 & ; t < t_0 \\ 1 & ; t > t_0 \end{cases}$$

Thus we obtain

$$q_1(t) = \frac{1}{\omega_1} \int_0^t Q_1(\tau) \sin \omega_1 (t - \tau) d\tau$$

$$= \frac{1}{2.8561} \int_0^t 0.7012 (0.1) \left\{ u(\tau) - u(\tau - 0.1) \right\} \sin 2.8561 (t - \tau) d\tau$$

$$= 0.02455 \left\{ \int_0^t u(\tau) \sin 2.8561 (t - \tau) d\tau - \int_0^t u(\tau - 0.1) \sin 2.8561 (t - \tau) d\tau \right\}$$

By noting that

$$\int_0^t u(\tau) \sin \Omega (t - \tau) d\tau = \frac{1}{\Omega} (1 - \cos \Omega t) \quad (6)$$

$$\text{and } \int_0^t u(\tau - t_0) \sin \Omega (t - \tau) d\tau = \frac{1}{\Omega} [1 - \cos \Omega (t - t_0)] \quad (7)$$

we can derive

$$q_1(t) = 0.008596 [1 - \cos 2.8561 t] \quad ; 0 < t < 0.1 \text{ sec}$$

$$= 0.008596 [\cos 2.8561 (t - 0.1) - \cos 2.8561 t] \quad ; t \geq 0.1 \text{ sec} \quad (8)$$

Similarly, we can derive

$$q_2(t) = -0.005379 [1 - \cos 6.7092 t] \quad ; 0 < t < 0.1 \text{ sec}$$

$$= -0.005379 [\cos 6.7092 (t - 0.1) - \cos 6.7092 t] \quad ; t \geq 0.1 \text{ sec} \quad (9)$$

$$q_3(t) = 0.001039 [1 - \cos 11.1088 t] \quad ; 0 < t < 0.1 \text{ sec}$$

$$= 0.001039 [\cos 11.1088 (t - 0.1) - \cos 11.1088 t] \quad ; t \geq 0.1 \text{ sec} \quad (10)$$

Thus the angular (physical) displacements of the pendulum can be expressed as:

$$\vec{x}(t) = [X] \vec{q}(t) \quad (11)$$

where $[X]$ is given by Eq. (1) and $\vec{q}(t)$ is given by Eqs. (8) to (10). Hence

$$x_1(t) = 0.003675 (1 - \cos 2.8561 t) - 0.005432 (1 - \cos 6.7092 t)$$

$$+ 0.001737 (1 - \cos 11.1088 t) \quad 0 < t < 0.1 \text{ sec}$$

$$= 0.003695 [\cos 2.8561 (t - 0.1) - \cos 2.8561 t]$$

$$- 0.005432 [\cos 6.7092 (t - 0.1) - \cos 6.7092 t]$$

$$+ 0.001737 [\cos 11.1088 (t - 0.1) - \cos 11.1088 t] \quad t \geq 0.1 \text{ sec}$$

$$\begin{aligned}
 x_2(t) &= 0.004775 (1 - \cos 2.8561 t) - 0.001916 (1 - \cos 6.7092 t) \\
 &\quad - 0.002858 (1 - \cos 11.1088 t) \quad 0 < t < 0.1 \text{ sec} \\
 &= 0.004775 \left[\cos 2.8561 (t - 0.1) - \cos 2.8561 t \right] \\
 &\quad - 0.001916 \left[\cos 6.7092 (t - 0.1) - \cos 6.7092 t \right] \\
 &\quad - 0.002858 \left[\cos 11.1088 (t - 0.1) - \cos 11.1088 t \right] \quad t \geq 0.1 \text{ sec} \\
 x_3(t) &= 0.006027 (1 - \cos 2.8561 t) + 0.013025 (1 - \cos 6.7092 t) \\
 &\quad + 0.001332 (1 - \cos 11.1088 t) \quad 0 < t < 0.1 \text{ sec} \\
 &= 0.006027 \left[\cos 2.8561 (t - 0.1) - \cos 2.8561 t \right] \\
 &\quad + 0.013025 \left[\cos 6.7092 (t - 0.1) - \cos 6.7092 t \right] \\
 &\quad + 0.001332 \left[\cos 11.1088 (t - 0.1) - \cos 11.1088 t \right] \quad t \geq 0.1 \text{ sec}
 \end{aligned}$$

6.82 $m = 2 \text{ kg}, k = 10,000 \text{ N/m},$

$$\sqrt{\frac{k}{m}} = \sqrt{\frac{10000}{2}} = 70.7107.$$

$$[m] = 2 \begin{bmatrix} 1 & 0 & 0 \\ 0 & 2 & 0 \\ 0 & 0 & 3 \end{bmatrix}$$

$$[k] = 10^4 \begin{bmatrix} 3 & -2 & 0 \\ -2 & 5 & -3 \\ 0 & -3 & 3 \end{bmatrix}$$

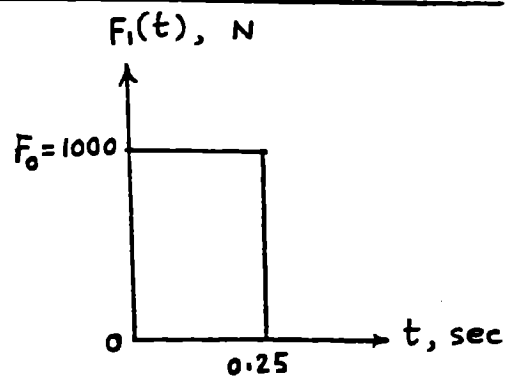

From the solution of Problem 6.46, we find the natural frequencies and mode shapes as:

$$\begin{aligned}
 \omega_1 &= 0.337627 \sqrt{\frac{k}{m}} ; \omega_2 = 1.414221 \sqrt{\frac{k}{m}} ; \omega_3 = 2.094278 \sqrt{\frac{k}{m}} \\
 \text{or } \omega_1 &= 23.8738 \text{ rad/sec} ; \omega_2 = 100.0008 \text{ rad/sec} ; \omega_3 = 148.0879 \text{ rad/sec}
 \end{aligned}$$

$$\vec{X}^{(1)} = a \begin{bmatrix} 1.0 \\ 1.4430 \\ 1.6286 \end{bmatrix} ; \vec{X}^{(2)} = b \begin{bmatrix} 1.0 \\ 0.5 \\ -0.5 \end{bmatrix} ; \vec{X}^{(3)} = c \begin{bmatrix} 1.0 \\ -0.6930 \\ 0.2047 \end{bmatrix}$$

Orthonormalization of modes:

$$\vec{X}^{(1)\top} [m] \vec{X}^{(1)} = 26.2430 a^2 = 1 \quad \text{or} \quad a = 0.1952$$

$$\vec{X}^{(2)\top} [m] \vec{X}^{(2)} = 4.5 b^2 = 1 \quad \text{or} \quad b = 0.4714$$

$$\vec{X}^{(3)\top} [m] \vec{X}^{(3)} = 4.1724 c^2 = 1 \quad \text{or} \quad c = 0.4896$$

Modal matrix:

$$[X] = \left[\vec{X}^{(1)} \quad \vec{X}^{(2)} \quad \vec{X}^{(3)} \right] = \begin{bmatrix} 0.1952 & 0.4714 & 0.4896 \\ 0.2817 & 0.2357 & -0.3393 \\ 0.3179 & -0.2357 & 0.1002 \end{bmatrix} \quad (1)$$

$$\vec{F}(t) = \begin{Bmatrix} F_1(t) \\ 0 \\ 0 \end{Bmatrix} \quad (2)$$

$$\vec{Q}(t) = [X]^T \vec{F}(t) = \begin{Bmatrix} 0.1952 F_1(t) \\ 0.4714 F_1(t) \\ 0.4896 F_1(t) \end{Bmatrix} \quad (3)$$

Solution of $q_i(t)$ without initial conditions:

$$q_i(t) = \frac{1}{\omega_i} \int_0^t Q_i(\tau) \sin \omega_i (t - \tau) d\tau ; i = 1, 2, 3 \quad (4)$$

$$F_1(t) = F_0 \left\{ u(t) - u(t - t_0) \right\}$$

where $F_0 = 1000$ N, $t_0 = 0.25$ sec, and $u(t)$ and $u(t - t_0)$ are unit step functions:

$$u(t) = \begin{cases} 0 & ; t < 0 \\ 1 & ; t > t_0 \end{cases}$$

$$u(t - t_0) = \begin{cases} 0 & ; t < t_0 \\ 1 & ; t > t_0 \end{cases}$$

Equations (3) give:

$$\vec{Q}(t) = \begin{Bmatrix} Q_1(t) \\ Q_2(t) \\ Q_3(t) \end{Bmatrix} = \begin{Bmatrix} 195.2 \left\{ u(t) - u(t - 0.25) \right\} \\ 471.4 \left\{ u(t) - u(t - 0.25) \right\} \\ 489.6 \left\{ u(t) - u(t - 0.25) \right\} \end{Bmatrix} \quad (5)$$

and Eqs. (4) yield:

$$q_1(t) = 0.3425 (1 - \cos 23.8738 t) ; 0 < t < 0.25 \text{ sec}$$

$$= 0.3425 \left[\cos 23.8738 (t - 0.25) - \cos 23.8738 t \right] ; t \geq 0.25 \text{ sec}$$

$$q_2(t) = 0.04714 (1 - \cos 100.0006 t) ; 0 < t < 0.25 \text{ sec}$$

$$= 0.04714 \left[\cos 100.0006 (t - 0.25) - \cos 100.0006 t \right] ; t \geq 0.25 \text{ sec}$$

$$q_3(t) = 0.02232 (1 - \cos 148.0879 t) ; 0 < t < 0.25 \text{ sec}$$

$$= 0.02232 \left[\cos 148.0879 (t - 0.25) - \cos 148.0879 t \right] ; t \geq 0.25 \text{ sec}$$

The physical displacements of the masses are given by:

$$\vec{x}(t) = [X] \vec{q}(t)$$

which can be explicitly expressed as:

$$\begin{aligned} x_1(t) &= 0.06686 (1 - \cos 23.8738 t) + 0.02222 (1 - \cos 100.0006 t) \\ &\quad + 0.01093 (1 - \cos 148.0879 t) ; 0 < t < 0.25 \text{ sec} \\ &= 0.06686 \left[\cos 23.8738 (t - 0.25) - \cos 23.8738 t \right] \\ &\quad + 0.02222 \left[\cos 100.0006 (t - 0.25) - \cos 100.0006 t \right] \\ &\quad + 0.01093 \left[\cos 148.0879 (t - 0.25) - \cos 148.0879 t \right] ; t \geq 0.25 \text{ sec} \\ x_2(t) &= 0.09648 (1 - \cos 23.8738 t) + 0.01111 (1 - \cos 100.0006 t) \\ &\quad - 0.007573 (1 - \cos 148.0879 t) ; 0 < t < 0.25 \text{ sec} \\ &= 0.09648 \left[\cos 23.8738 (t - 0.25) - \cos 23.8738 t \right] \\ &\quad + 0.01111 \left[\cos 100.0006 (t - 0.25) - \cos 100.0006 t \right] \\ &\quad - 0.007573 \left[\cos 148.0879 (t - 0.25) - \cos 148.0879 t \right] ; t \geq 0.25 \text{ sec} \\ x_3(t) &= 0.1089 (1 - \cos 23.8738 t) - 0.01111 (1 - \cos 100.0006 t) \\ &\quad + 0.002236 (1 - \cos 148.0879 t) ; 0 < t < 0.25 \text{ sec} \\ &= 0.1089 \left[\cos 23.8738 (t - 0.25) - \cos 23.8738 t \right] \\ &\quad - 0.01111 \left[\cos 100.0006 (t - 0.25) - \cos 100.0006 t \right] \\ &\quad + 0.002236 \left[\cos 148.0879 (t - 0.25) - \cos 148.0879 t \right] ; t \geq 0.25 \text{ sec} \end{aligned}$$

6.83

Equations of motion $[m] \ddot{\vec{x}} + [c] \dot{\vec{x}} + [k] \vec{x} = \vec{F}$... (E.1)

where

$$[m] = \begin{bmatrix} m_1 & 0 & 0 \\ 0 & m_2 & 0 \\ 0 & 0 & m_3 \end{bmatrix}, [c] = \begin{bmatrix} c_1 + c_2 & -c_2 & 0 \\ -c_2 & c_2 + c_3 & -c_3 \\ 0 & -c_3 & c_3 + c_4 \end{bmatrix},$$

$$[k] = \begin{bmatrix} k_1 + k_2 & -k_2 & 0 \\ -k_2 & k_2 + k_3 & -k_3 \\ 0 & -k_3 & k_3 + k_4 \end{bmatrix}, \vec{x} = \begin{Bmatrix} x_1 \\ x_2 \\ x_3 \end{Bmatrix}, \vec{F} = \begin{Bmatrix} F_1 = F_0 \cos \omega t \\ F_2 = 0 \\ F_3 = 0 \end{Bmatrix}$$

Since $F_j(t) = \text{Re} [F_{j0} e^{i\omega t}]$ with $F_{10} = F_0$, and $F_{20} = F_{30} = 0$, we assume $x_j(t) = X_j e^{i\omega t}$; $j=1,2,3$. Then (E.1) becomes

$$[Z_{rs}(i\omega)] \vec{X} = \vec{F}_0 \quad \dots (E.2)$$

where $Z_{11}(i\omega) = -m_1 \omega^2 + (c_1 + c_2) i\omega + (k_1 + k_2) = -\omega^2 + 2i\omega + 200$

$$Z_{12}(i\omega) = Z_{21}(i\omega) = -c_2 i\omega - k_2 = -i\omega - 100$$

$$Z_{13}(i\omega) = Z_{31}(i\omega) = 0$$

$$Z_{22}(i\omega) = -m_2 \omega^2 + (c_2 + c_3) i\omega + (k_2 + k_3) = -\omega^2 + 2i\omega + 200 \dots (E.3)$$

$$Z_{23}(i\omega) = Z_{32}(i\omega) = -c_3 i\omega - k_3 = -i\omega - 100$$

$$Z_{33}(i\omega) = -m_3 \omega^2 + (c_3 + c_4) i\omega + (k_3 + k_4) = -\omega^2 + 2i\omega + 200$$

(E.2) becomes

$$\begin{aligned} (2i+199) X_1 - (i+100) X_2 + (0) X_3 &= 10 \\ -(i+100) X_1 + (2i+199) X_2 - (i+100) X_3 &= 0 \\ (0) X_1 - (i+100) X_2 + (2i+199) X_3 &= 0 \end{aligned} \quad \dots (E.4)$$

Solution of (E.4) can be expressed as

where $X_j = \frac{\Delta_j}{\Delta} ; j=1,2,3 \quad \dots (E.5)$

$$\Delta_1 = \begin{vmatrix} 10 & -(i+100) & 0 \\ 0 & (2i+199) & -(i+100) \\ 0 & -(i+100) & (2i+199) \end{vmatrix} = 295980 + 5960i$$

$$\Delta_2 = \begin{vmatrix} (2i+199) & 10 & 0 \\ -(i+100) & 0 & -(i+100) \\ 0 & 0 & (2i+199) \end{vmatrix} = 198980 + 3990i$$

$$\Delta_3 = \begin{vmatrix} (2i+199) & -(i+100) & 10 \\ -(i+100) & (2i+199) & 0 \\ 0 & -(i+100) & 0 \end{vmatrix} = 99990 + 2000i$$

$$\Delta = \begin{vmatrix} (2i+199) & -(i+100) & 0 \\ -(i+100) & (2i+199) & -(i+100) \\ 0 & -(i+100) & (2i+199) \end{vmatrix} = 118002i + 3899409$$

Using (E.5), we get

$$X_1 = \frac{87639.682}{1154850.392 + 11685.754i} ; \text{ Amplitude} = 0.0758845 \text{ m}$$

Phase angle = 0.5798°

$$X_2 = \frac{39608.961}{776375.228 + 7921.396i} ; \text{ Amplitude} = 0.0510152 \text{ m}$$

Phase angle = 0.5845°

$$X_3 = \frac{10002.000}{390137.914 + 4000.202i} ; \text{ Amplitude} = 0.0256357 \text{ m}$$

Phase angle = 0.5874°

Thus the steady state responses are:

$$x_1(t) = 0.0758845 \cos(\omega t + 0.5798^\circ) \text{ m}$$

$$x_2(t) = 0.0510152 \cos(\omega t + 0.5845^\circ) \text{ m}$$

$$x_3(t) = 0.0256357 \cos(\omega t + 0.5874^\circ) \text{ m}$$

6.84 Modal matrix can be expressed as $[X] = [\vec{X}^{(1)} \ \vec{X}^{(2)} \ \vec{X}^{(3)}]$

Using Eq. (6.122), $\vec{x}(t) = [X] \vec{q}(t)$ where $\vec{q}(t) = \begin{Bmatrix} q_1(t) \\ q_2(t) \\ q_3(t) \end{Bmatrix}$

$12 \times 1 \quad 12 \times 3 \quad 3 \times 1$

equations of motion can be written as

$$[m][\ddot{x}] + [c][\dot{x}] + [k][x] = -[m]\ddot{u}_1, \ddot{x}_0(t)$$

Premultiplication by $[x]^T$ gives

$$[x]^T [m][\ddot{x}] + [x]^T [c][\dot{x}] + [x]^T [k][x] = -[x]^T [m]\ddot{u}_1, \ddot{x}_0(t) \quad \dots (E.1)$$

Assuming that the mass matrix is diagonal and the damping matrix is proportional, (E.1) can be expressed in scalar form as

$$m_{ii} \ddot{\vartheta}_i + c_{ii} \dot{\vartheta}_i + k_{ii} \vartheta_i = -\ddot{x}_0(t) \sum_{j=1}^{12} m_j X_j^{(i)}, \quad i=1,2,3 \quad \dots (E.2)$$

where m_{ii} , c_{ii} and k_{ii} are generalized mass, generalized damping, and generalized stiffness, m_j is the mass at the j^{th} d.o.f. and $X_j^{(i)}$ is the j^{th} component of the vector $\vec{X}^{(i)}$.

Here
$$m_{ii} = \sum_{j=1}^{12} m_j (X_j^{(i)})^2 = m \sum_{j=1}^{12} (X_j^{(i)})^2$$

$$c_{ii} = 2\gamma_i \omega_i \quad \text{and} \quad \frac{k_{ii}}{m_{ii}} = \omega_i^2 \quad ; \quad i=1,2,3$$

where m = mass at each d.o.f.

Eq.(E.2) can be written, noting that there is no damping in the system, as

$$\ddot{\vartheta}_i + \omega_i^2 \vartheta_i = - \frac{\ddot{x}_0(t) \left\{ \sum_{j=1}^{12} m_j X_j^{(i)} \right\}}{\left\{ \sum_{j=1}^{12} m_j (X_j^{(i)})^2 \right\}} = -\ddot{x}_0(t) \frac{\sum_{j=1}^{12} X_j^{(i)}}{\sum_{j=1}^{12} (X_j^{(i)})^2} \quad ; \quad i=1,2,3 \quad \dots (E.3)$$

By noting that

$$\sum_{j=1}^{12} X_j^{(i)} = 7.964 \text{ for } i=1, -2.67 \text{ for } i=2, 1.618 \text{ for } i=3,$$

$$\sum_{j=1}^{12} (X_j^{(i)})^2 = 6.275658 \text{ for } i=1, 6.48612 \text{ for } i=2, 6.90962 \text{ for } i=3,$$

Eqs.(E.3) can be reduced to

$$\begin{aligned} \ddot{\vartheta}_1(t) + 50625.0 \vartheta_1(t) &= -1.26903 \ddot{x}_0(t) \\ \ddot{\vartheta}_2(t) + 435600.0 \vartheta_2(t) &= 0.411648 \ddot{x}_0(t) \\ \ddot{\vartheta}_3(t) + 1210000.0 \vartheta_3(t) &= -0.234166 \ddot{x}_0(t) \end{aligned} \quad \dots (E.4)$$

6.85 Eigenvalue problem:

$$\lambda [m] \vec{X} = [k] \vec{X}$$

With $\lambda = \omega^2$, $[m] = \begin{bmatrix} 1 & 0 & 0 \\ 0 & 2 & 0 \\ 0 & 0 & 1 \end{bmatrix}$, $[k] = \begin{bmatrix} 1 & -2 & 1 \\ -2 & 4 & -2 \\ 1 & -2 & 1 \end{bmatrix}$

Solution using MATLAB:

```
% Ex6_85.m
>> k = [1 -2 1; -2 4 -2; 1 -2 1]
```

k =

$$\begin{bmatrix} 1 & -2 & 1 \\ -2 & 4 & -2 \\ 1 & -2 & 1 \end{bmatrix}$$

```
>> m = [1 0 0; 0 2 0; 0 0 1]
```

m =

$$\begin{bmatrix} 1 & 0 & 0 \\ 0 & 2 & 0 \\ 0 & 0 & 1 \end{bmatrix}$$

```
>> [V, D] = eig(k, m)
```

V =

$$\begin{bmatrix} -0.6439 & -0.5792 & 0.5000 \\ -0.4876 & 0.1105 & -0.5000 \\ -0.3314 & 0.8001 & 0.5000 \end{bmatrix}$$

D =

$$\begin{bmatrix} -0.0000 & 0 & 0 \\ 0 & 0.0000 & 0 \\ 0 & 0 & 4.0000 \end{bmatrix}$$

6.86 $x_1(t) = x_{20} (0.1527 \cos 0.5626 \sqrt{\frac{P}{\ell m}} t + 0.09847 \cos 0.9158 \sqrt{\frac{P}{\ell m}} t - 0.2512 \cos 1.5848 \sqrt{\frac{P}{\ell m}} t)$ (1)

$x_2(t) = x_{20} (0.2087 \cos 0.5626 \sqrt{\frac{P}{\ell m}} t + 0.03177 \cos 0.9158 \sqrt{\frac{P}{\ell m}} t + 0.7594 \cos 1.5848 \sqrt{\frac{P}{\ell m}} t)$ (2)

$x_3(t) = x_{20} (0.1987 \cos 0.5626 \sqrt{\frac{P}{\ell m}} t - 0.06157 \cos 0.9158 \sqrt{\frac{P}{\ell m}} t - 0.1372 \cos 1.5848 \sqrt{\frac{P}{\ell m}} t)$ (3)

Data: $x_{20} = 0.5$, $P = 100$, $\ell = 5$, $m = 2$

MATLAB Solution of Eqs. (1) - (3):

```

% Ex6_86.m
x20 = 0.5;
p = 100;
l = 5;
m = 2;
c = sqrt(p/(l*m));
for i = 1: 501
    t(i) = 10*(i-1)/500;
    x1(i) = x20 * ( 0.1527*cos(0.5626*c*t(i)) + ...
        0.09847*cos(0.9158*c*t(i)) - 0.2512*cos(1.5848*c*t(i)) );
    x2(i) = x20 * ( 0.2087*cos(0.5626*c*t(i)) + ...
        0.03177*cos(0.9158*c*t(i)) + 0.7594*cos(1.5848*c*t(i)) );
    x3(i) = x20 * ( 0.1987*cos(0.5626*c*t(i)) - ...
        0.06157*cos(0.9158*c*t(i)) - 0.1372*cos(1.5848*c*t(i)) );
end
plot(t,x1);
hold on;
plot(t,x2,'--');
plot(t,x3,':');
xlabel('t');
ylabel('x1(t): solid line x2(t): dashed line x3(t): dotted line');

```

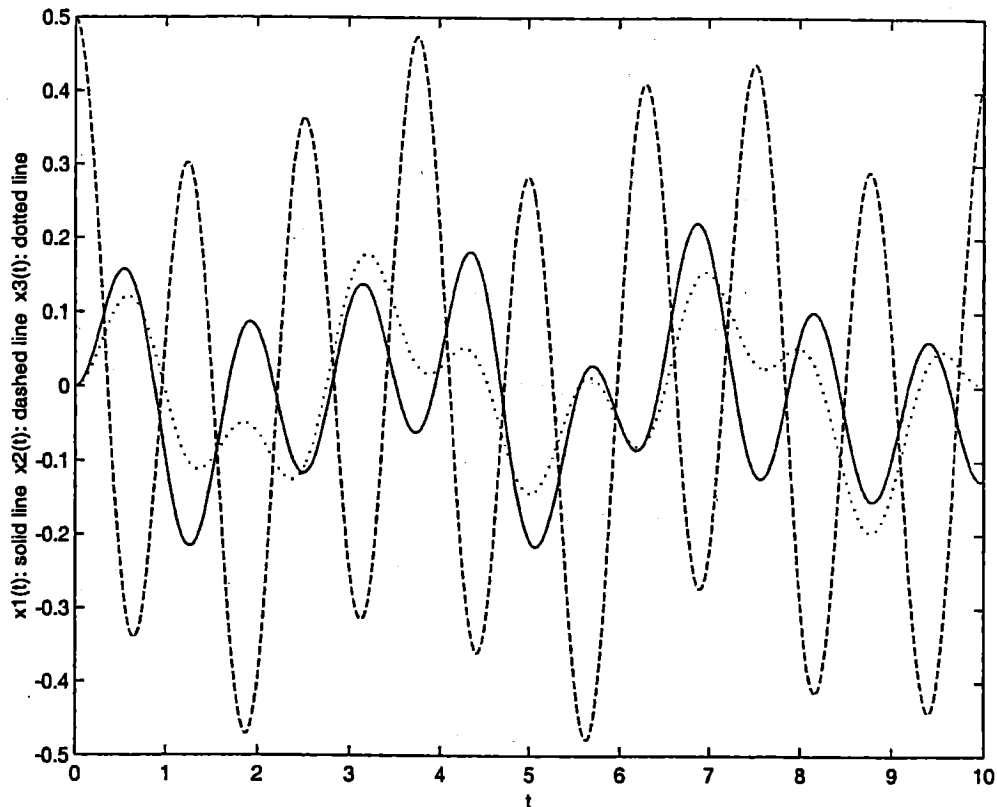

6.87

Equations of motion:

$$2m \ddot{x}_1 + 3k x_1 - k x_2 - k x_3 = 0 \quad (1)$$

$$m \ddot{x}_2 - k x_1 + k x_2 = 0 \quad (2)$$

$$m \ddot{x}_3 - k x_1 + k x_3 = F(t) = F_0 \sin \omega t \quad (3)$$

Using the data: $m=1$, $k=1000$, $F_0=5$, $\omega=10$,
Eqs. (1)-(3) can be expressed as

$$\ddot{x}_1 = -1500 x_1 + 500 x_2 + 500 x_3 \quad (4)$$

$$\ddot{x}_2 = 1000 x_1 - 1000 x_2 \quad (5)$$

$$\ddot{x}_3 = 1000 x_1 - 1000 x_3 + 5 \sin 10t \quad (6)$$

Let

$$\vec{Y} = \begin{Bmatrix} y_1 \\ y_2 \\ y_3 \\ y_4 \\ y_5 \\ y_6 \end{Bmatrix} = \begin{Bmatrix} x_1 \\ \dot{x}_1 \\ x_2 \\ \dot{x}_2 \\ x_3 \\ \dot{x}_3 \end{Bmatrix} \quad \text{and} \quad \vec{Y}(0) = \begin{Bmatrix} 0 \\ 0 \\ 0 \\ 0 \\ 0 \\ 0 \end{Bmatrix}$$

Eqs. (4) - (6) can be rewritten as

$$\frac{d\vec{Y}}{dt} = \begin{Bmatrix} y_2 \\ -1500 y_1 + 500 y_3 + 500 y_5 \\ y_4 \\ 1000 y_1 - 1000 y_3 \\ y_6 \\ 1000 y_1 - 1000 y_5 + 5 \sin 10t \end{Bmatrix} \quad (7)$$

Solution of Eq. (7) using MATLAB:

```
% Ex6_87.m
% This program will use the function dfunc6_87.m, they should
% be in the same folder
tspan = [0: 0.01: 10];
x0 = [0.0; 0.0; 0.0; 0.0; 0.0; 0.0];
[t,x] = ode23('dfunc6_87', tspan, x0);
subplot(311);
plot(t,x(:,1));
xlabel('t');
ylabel('x1(t)');
subplot(312);
plot(t,x(:,3));
xlabel('t');
ylabel('x2(t)');
subplot(313);
plot(t,x(:,5));
xlabel('t');
ylabel('x3(t)');

% dfunc6_87.m
function f = dfunc6_87(t,x)
F0 = 5;
```

```

w = 10;
m = 1;
k = 1000;
f = zeros(6,1);
f(1) = x(2);
f(2) = -1500*x(1) + 500*x(3) + 500*x(5);
f(3) = x(4);
f(4) = 1000*x(1) - 1000*x(3);
f(5) = x(6);
f(6) = 1000*x(1) - 1000*x(5) + 5*sin(10*t);

```

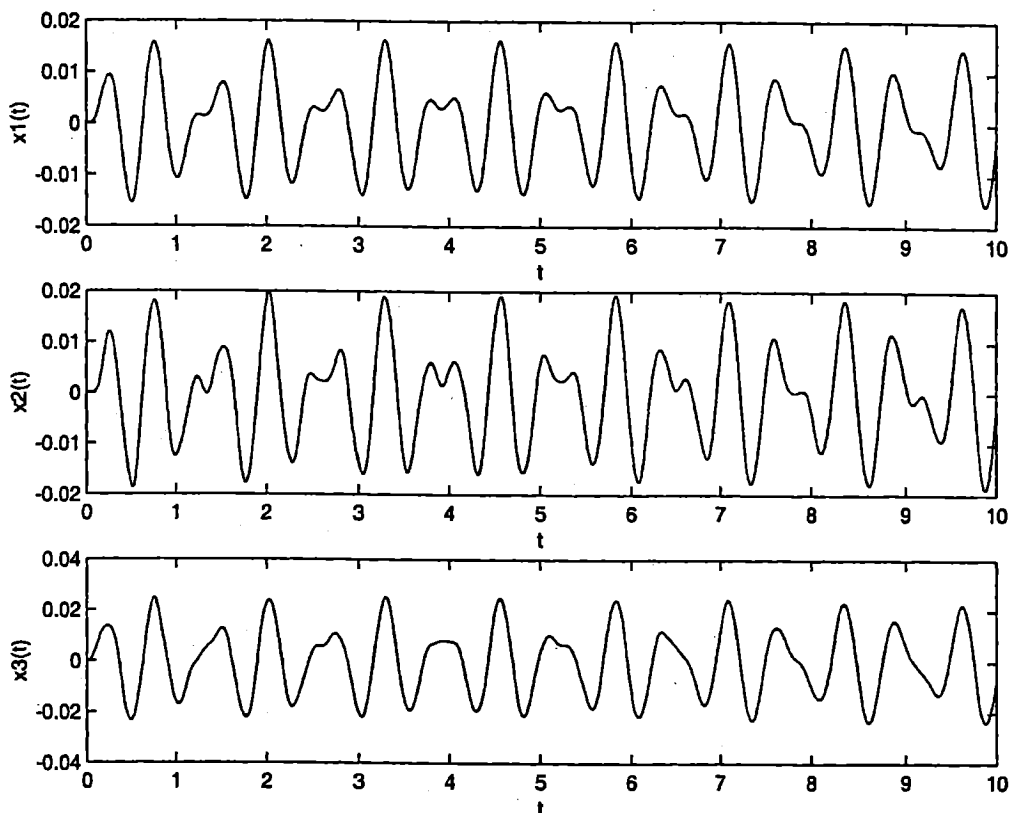

6.88

Roots of $f(x) = x^{12} - 2 = 0$ using MATLAB:

```

% Ex6_88.m
>> x = roots([1 zeros(1,11) -2])

```

x =

```

-1.0595
-0.9175 + 0.5297i
-0.9175 - 0.5297i
-0.5297 + 0.9175i
-0.5297 - 0.9175i
0.0000 + 1.0595i
0.0000 - 1.0595i
0.5297 + 0.9175i
0.5297 - 0.9175i
1.0595
0.9175 + 0.5297i
0.9175 - 0.5297i

```

6.89

Equations of motion can be rewritten as

$$\ddot{x}_1 = -1.5 \dot{x}_1 + 0.5 \dot{x}_2 - 14 x_1 + 6 x_2 + 0.5 \cos 2t \quad (1)$$

$$\ddot{x}_2 = 0.25 \dot{x}_1 - \dot{x}_2 + 0.75 \dot{x}_3 + 3 x_1 - 5 x_2 + 2 x_3 \quad (2)$$

$$\ddot{x}_3 = 0.5 \dot{x}_2 - 0.5 \dot{x}_3 + 1.3333 x_2 - 1.3333 x_3 \quad (3)$$

$$\text{Let } \vec{Y} = \begin{Bmatrix} y_1 \\ y_2 \\ y_3 \\ y_4 \\ y_5 \\ y_6 \end{Bmatrix} = \begin{Bmatrix} x_1 \\ \dot{x}_1 \\ x_2 \\ \dot{x}_2 \\ x_3 \\ \dot{x}_3 \end{Bmatrix} \quad \text{and } \vec{Y}(0) = \begin{Bmatrix} 0 \\ 0 \\ 0 \\ 0 \\ 0 \\ 0 \end{Bmatrix}$$

Eqs. (1) - (3) can be expressed as

$$\frac{d\vec{Y}}{dt} = \begin{Bmatrix} y_2 \\ -1.5 y_2 + 0.5 y_4 - 14 y_1 + 6 y_3 + 0.5 \cos 2t \\ y_4 \\ 0.25 y_2 - y_4 + 0.75 y_6 + 3 y_1 - 5 y_3 + 2 y_5 \\ y_6 \\ 0.5 y_4 - 0.5 y_6 + 1.3333 y_3 - 1.3333 y_5 \end{Bmatrix} \quad (4)$$

Solution of Eq. (4) using MATLAB:

```
% Ex6_89.m
% This program will use the function dfunc6_89.m, they should
% be in the same folder
tspan = [0: 0.01: 20];
x0 = [0.0; 0.0; 0.0; 0.0; 0.0; 0.0];
[t,x] = ode23('dfunc6_89', tspan, x0);
subplot(311);
plot(t,x(:,1));
xlabel('t');
ylabel('x1(t)');
subplot(312);
plot(t,x(:,3));
xlabel('t');
ylabel('x2(t)');
subplot(313);
plot(t,x(:,5));
xlabel('t');
ylabel('x3(t)');
```

```

% dfunc6_89.m
function f = dfunc6_89(t,x)
f = zeros(6,1);
f(1) = x(2);
f(2) = -1.5*x(2) + 0.5*x(4) - 14*x(1) + 6*x(3) + 0.5*cos(2*t);
f(3) = x(4);
f(4) = 0.25*x(2) - x(4) + 0.75*x(6) + 3*x(1) - 5*x(3) + 2*x(5);
f(5) = x(6);
f(6) = 0.5*x(4) - 0.5*x(6) + 1.3333*x(3) - 1.3333*x(5);
    
```

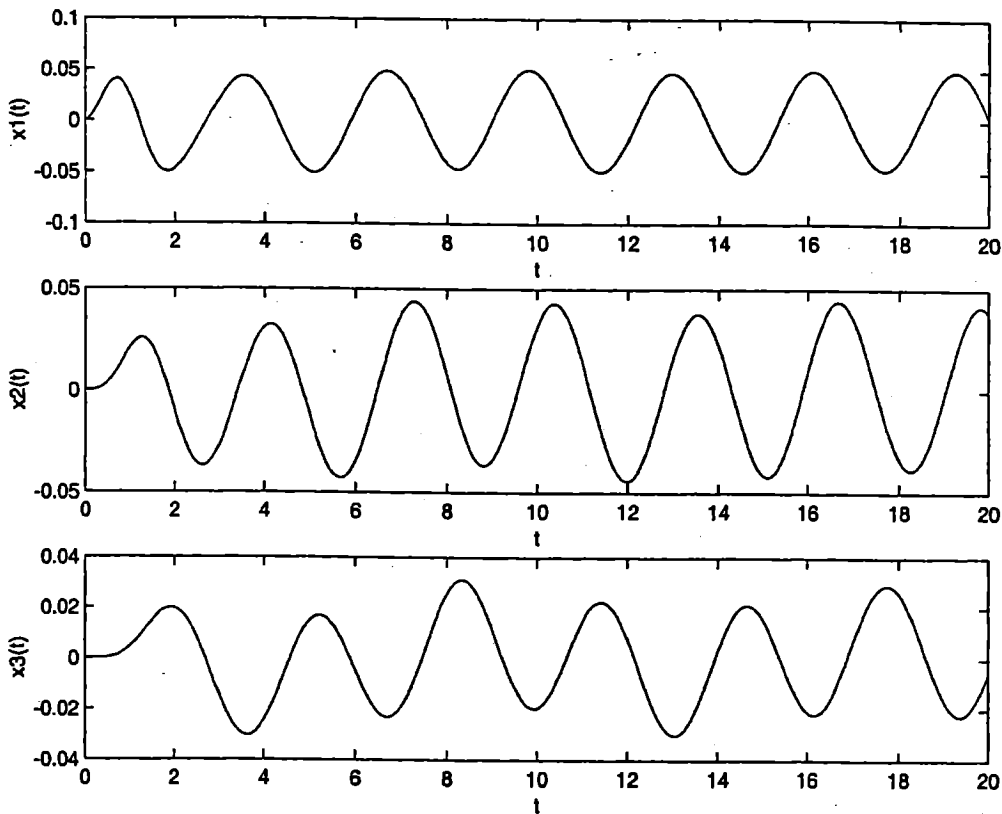

Equations of motion:

6.90

$$\begin{bmatrix} 1 & 0 & 0 \\ 0 & 1 & 0 \\ 0 & 0 & 1 \end{bmatrix} \ddot{\vec{x}} + \begin{bmatrix} 2 & -1 & 0 \\ -1 & 2 & -1 \\ 0 & -1 & 2 \end{bmatrix} \dot{\vec{x}} + \begin{bmatrix} 200 & -100 & 0 \\ -100 & 200 & -100 \\ 0 & -100 & 200 \end{bmatrix} \vec{x} = \begin{Bmatrix} 10 \cos t \\ 0 \\ 0 \end{Bmatrix}$$

i.e.,

$$\ddot{x}_1 = -2\dot{x}_1 + \dot{x}_2 - 200x_1 + 100x_2 + 10 \cos t \tag{1}$$

$$\ddot{x}_2 = \dot{x}_1 - 2\dot{x}_2 + \dot{x}_3 + 100x_1 - 200x_2 + 100x_3 \tag{2}$$

$$\ddot{x}_3 = \dot{x}_2 - 2\dot{x}_3 + 100x_2 - 200x_3 \tag{3}$$

Defining $\vec{Y} = \begin{Bmatrix} y_1 \\ y_2 \\ \vdots \\ y_6 \end{Bmatrix} = \begin{Bmatrix} x_1 \\ \dot{x}_1 \\ x_2 \\ \vdots \\ \dot{x}_3 \end{Bmatrix}$ and using $\vec{Y}(0) = \vec{0}$

Eqs. (1) - (4) can be rewritten as

$$\frac{d\vec{Y}}{dt} = \begin{cases} y_2 \\ -2y_2 + y_4 - 200y_1 + 100y_3 + 10 \cos t \\ y_4 \\ y_2 - 2y_4 + y_6 + 100y_1 - 200y_3 + 100y_5 \\ y_6 \\ y_4 - 2y_6 + 100y_3 - 200y_5 \end{cases} \quad (4)$$

Solution of Eq. (4) using MATLAB:

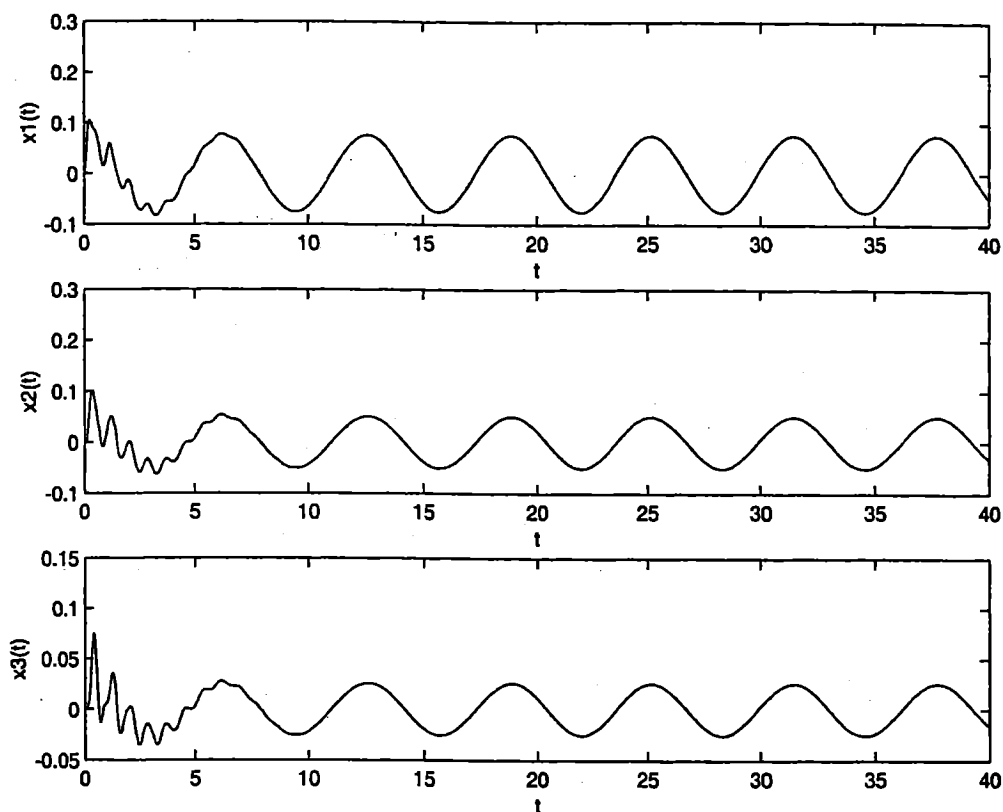

```
% dfunc6_90.m
function f = dfunc6_90(t,x)
f = zeros(6,1);
f(1) = x(2);
f(2) = -2*x(2) + x(4) - 200*x(1) + 100*x(3) + 10*cos(t);
f(3) = x(4);
f(4) = x(2) - 2*x(4) + 100*x(1) - 200*x(3) + 100*x(5);
f(5) = x(6);
f(6) = x(4) - 2*x(6) + 100*x(3) - 200*x(5);
```

```

% Ex6_90.m
% This program will use the function dfunc6_90.m, they should
% be in the same folder
tspan = [0: 0.01: 40];
x0 = [0.0; 0.0; 0.0; 0.0; 0.0; 0.0];
[t,x] = ode23('dfunc6_90', tspan, x0);
subplot(311);
plot(t,x(:,1));
xlabel('t');
ylabel('x1(t)');
subplot(312);
plot(t,x(:,3));
xlabel('t');
ylabel('x2(t)');
subplot(313);
plot(t,x(:,5));
xlabel('t');
ylabel('x3(t)');

```

6.91

Results of Ex6_91

>> program7

polynomial expansion of a determinantal equation

data: determinant A:

5.000000e+000	3.000000e+000	2.000000e+000
3.000000e+000	6.000000e+000	4.000000e+000
1.000000e+000	2.000000e+000	6.000000e+000

result: polynomial coefficients in

pcf(np)*(x^n)+pcf(n)*(x^(n-1))+...+pcf(2)+pcf(1)=0

-9.800000e+001 7.700000e+001 -1.700000e+001 1.000000e+000

6.92

```

%=====
%
% Program8.m
% Main program which calls the function MODAL
%
%=====
% Run "Program8" in MATLAB command window, Progrm8.m and modal.m
% should be in the same folder, and set the path to this folder
% following line contain problem-dependent data
n=3;
nvec=3;
nstep=300;
delt=0.01;
xm=[41.4 0.0 0.0; 0.0 38.8 0.0; 0.0 0.0 25.88];
omf=[5 10 20];
om=[25.076 53.578 110.907];
z=[0.001 0.001 0.001];
x0=[0.0 0.0 0.0];
xd0=[0.0 0.0 0.0];
ev=[1.0 1.0 1.0; 1.303 0.860 -1.0; 1.947 -1.685 0.183];
%end of problem-dependent data

```

```

for i=1:nstep
    time=i*delt;
    f(1,i)=5000*cos(5*time);
    f(2,i)=10000*cos(10*time);
    f(3,i)=20000*cos(20*time);
end
for i=1:nvec
    for j=1:n
        evt(i,j)=ev(i,j);
    end
end
[x,t]=modal(xm,om,omf,z,x0,xd0,f,delt,ev,evt,nstep,n,nvec);
fprintf('\n Response of system using modal analysis \n\n');
for i=1:n
    fprintf('\n Coordinate %2.0f \n',i);
    fprintf(' %8.5e %8.5e %8.5e %8.5e %8.5e\n',x(i,1:nstep));
end
for i = 1: n
    plot(t,x(i,1:nstep));
    hold on;
end
xlabel('t');
ylabel('x');
gtext('Coordinate 3');
gtext('Coordinate 2');
gtext('Coordinate 1' );
%=====
%
% function modal.m
%
%=====
function [x,t]=modal(xm,om,omf,z,x0,xd0,f,delt,ev,evt,nstep,n,nvec);
t(1)=delt;
for i=2:nstep
    t(i)=t(i-1)+delt;
end
% normalization of modal matrix with respect to the mass matrix
% xmx=matmul(xm,ev,n,n,nvec);
% xtmx=matmul(evt,xmx,nvec,n,nvec);
xmx=xm*ev;
xtmx=evt*xmx;
for i=1:nvec
    for j=1:n
        ev(j,i)=ev(j,i)/sqrt(xtmx(i,i));
    end
end
% conversion of information to normal coordinates
for i=1:nvec
    y0(i)=0.0;
    yd0(i)=0.0;
end
for i=1:nvec
    for j=1:n
        yo(i)=y0(i)+ev(j,i)*x0(j);
        yd0(i)=yd0(i)+ev(j,i)*xd0(j);
    end
end
end

```

```

for i=1:nvec
    for j=1:n
        evt(i,j)=ev(j,i);
    end
end
% q=matmul(evt,f,nvec,n,nstep);
q=evt*f;
for i=1:nvec
    r=omf(i)/om(i);
    pp=y0(i);
    qq=yd0(i);
    zi=z(i);
    omeg=om(i);
    omd=omeg*sqrt(1-zi^2);
    for j=1:nstep
        if j~=1
            pp=u(i,j-1);
            qq=v(i,j-1);
        end
        c1=exp(-zi*omeg*delt);
        c2=cos(omd*delt);
        c3=sin(omd*delt);
        c4=(qq+omeg*zi*pp)/omd;
        c5=omeg*zi/omd;
        c6=q(i,j)/(omeg^2);
        u(i,j)=c1*(pp*c2+c3*c4)+c6*(1-c1*(c2+c3*c5));
        v(i,j)=omd*c1*(-pp*c3+c2*c4-c5*(pp*c2+c3*c4))+c6*omd*c1*c3*(1+c5^2);
    end
end
% finding the solution in the original coordinates
% x=matmul(ev,u,n,nvec,nstep);
x=ev*u;

%=====
%
% function matmul.m
%
%=====
function [a]=matmul(b,c,l,m,n)
% Matrix multiplication subroutine: A=B*C
% b(l,m) and c(m,n) are input matrices, A(l,n) is output matrix
for i=1:l
    for j=1:n
        a(i,j)=0;
        for k=1:m
            a(i,j)=a(i,j)+b(i,k)*c(k,j);
        end
    end
end
end
end

```

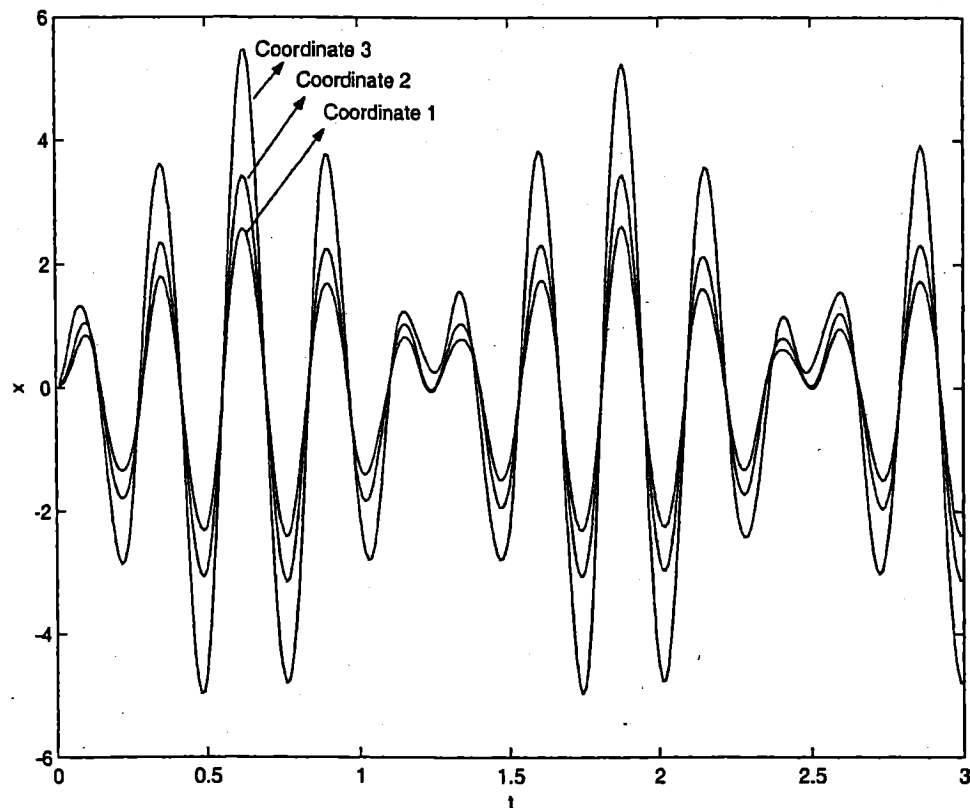

Results of Ex6_92

>> program8

Response of system using modal analysis

Coordinate 1

1.16587e-002 4.77899e-002 1.10778e-001 2.01670e-001 3.17703e-001
 4.51127e-001 5.89314e-001 7.15610e-001 8.10748e-001 8.55251e-001
 8.33049e-001 7.35446e-001 5.63789e-001 3.29513e-001 5.16989e-002
 -2.46502e-001 -5.41192e-001 -8.10289e-001 -1.03560e+000 -1.20447e+000
 :
 :

Coordinate 2

1.94937e-002 7.72115e-002 1.71039e-001 2.97350e-001 4.49827e-001
 6.17690e-001 7.84560e-001 9.29302e-001 1.02905e+000 1.06321e+000
 1.01695e+000 8.83330e-001 6.64302e-001 3.71083e-001 2.35527e-002
 -3.51910e-001 -7.26226e-001 -1.07196e+000 -1.36651e+000 -1.59315e+000
 :
 :

Coordinate 3

5.07839e-002 1.94324e-001 4.06865e-001 6.55062e-001 9.01966e-001
 1.11328e+000 1.26237e+000 1.33292e+000 1.31883e+000 1.22192e+000
 1.04849e+000 8.06186e-001 5.01856e-001 1.41193e-001 -2.69837e-001
 -7.22160e-001 -1.20031e+000 -1.68000e+000 -2.12777e+000 -2.50340e+000
 :
 :

6.93

Results of Ex6_93

Please input the dimension n of matrix A:

3

Please input matrix A row by row:

5 3 2

3 6 4

1 2 6

POLYNOMIAL EXPANSION OF A DETERMINANTAL EQUATION

DATA: DETERMINANT A:

5.000000	3.000000	2.000000
3.000000	6.000000	4.000000
1.000000	2.000000	6.000000

RESULTS: POLYNOMIAL COEFFICIENTS IN

$$PCF(NP) * (X ** N) + PCF(N) * (X ** (N - 1)) + \dots + PCF(2) * X + PCF(1) = 0$$

-98.000000	77.000000	-17.000000	1.000000
------------	-----------	------------	----------

6.94

Results of EX6_94

Please input N, NVEC and NSTEP:

3 3 300

please input delt

0.01

Please input omf:

5 10 20

Please input f0:

5000 10000 20000

Please input mass matrix xm row by row:

41.4 0.0 0.0

0.0 38.8 0.0

0.0 0.0 25.88

Please input matrix ev row by row:

1.0 1.0 1.0

1.303 0.860 -1.0

1.947 -1.685 0.183

Please input array om:

25.076 53.578 110.907

RESPONSE OF SYSTEM USING MODAL ANALYSIS

COORDINATE	1				
	0.006208	0.026654	0.065312	0.125053	0.205024
	0.300019	0.401234	0.496988	0.573101	0.614066
	0.606065	0.541135	0.420141	0.252677	0.054151
	-0.157847	-0.366008	-0.554538	-0.710303	-0.824498
	-0.893819	-0.919633	-0.905025	-0.851612	-0.758411
	:				
	:				
COORDINATE	2				
	0.012775	0.050530	0.112047	0.195985	0.300008
	0.418443	0.540214	0.649161	0.727132	0.758080
	0.730937	0.640590	0.488040	0.280835	0.033452
	-0.233891	-0.498681	-0.740536	-0.944195	-1.099724
	-1.200809	-1.243237	-1.224671	-1.145067	-1.006415
	:				
	:				

```

COORDINATE      3
    0.037474    0.142990    0.297929    0.476242    0.649396
    0.791676    0.884394    0.917875    0.890876    0.808089
    0.676890    0.504451    0.295938    0.054152   -0.219265
   -0.521240   -0.844032   -1.172584   -1.483733   -1.747970
   -1.933446   -2.011182   -1.960222   -1.771687   -1.451017
    :
    :

```

```

/* Program8.cpp
Program 8
subroutine MODAL is given for the modal analysis of a multidegree of freedom system.
XM   = Array of size N by N, in which the mass matrix [m] is stored. Input data
OM   = Array of size NVEC, in which the natural frequencies are stored. Input data.
T    = Array of size NSTEP, in which the times t1, t2, tNSTEP are stored.
Z    = Array of size NVEC, in which the modal damping ratios of various modes are stored.
      Input data.
X0   = Array of size N, in which the initial values x1(0), x2(0), ..., xn(0) are stored.
      Input data.
XD0  = Array of size N, in which the initial values x1'(0), x2'(0), ..., xn'(0) are stored.
      Input data.
Y0,YD0 = Array of size NVEC.
Q    = Array of size NVEC by NSTEP.
F    = Array of size N by NSTEP, in which the magnitudes of the forces applied to the
      different masses at times t1, t2, ..., tNSTEP are stored. Input data.
DELT = Time step used for calculation, delta t = t(i+1) - t(i). Input data.
EV   = Array of size N by NVEC, in which the normal modes are stored columnwise. Input data
EVT  = Array of size NVEC by N = transpose of the matrix EV.
XMX  = Array of size N by NVEC.
XTMX = Array of size NVEC by NVEC.
X    = Array of size N by NSTEP, in which the displacements of the masses m1, m2, ..., mn at
      various time stations t1, t2, ..., tNSTEP are stored. Output.
U,V  = Arrays of size NVEC by NSTEP.
NSTEP = Number of time stations or integration points t1, t2, ..., tNSTEP. Input data.
N     = Number of degrees of freedom of the system. Input data.
NVEC  = Number of modes used in the analysis. Input data.

```

```

example: [m]x'' + [c]x' + [k]x = f with x(0) = x0, x'(0) = x0'
[m] = {[1, 0, 0],[0, 1, 0],[0, 0, 1]},
EV = {[1.0, 1.0, 1.0],[1.8019, 0.4450, -1.2468],[2.2470, -0.8020, 0.5544]}
n = 3, NVEC = 3, z_i = 0.01, i = 1, 2, 3.
w1 = 0.89008, w2 = 1.4942, w3 = 3.6050.
x0 = {0;0;0}, xd0 = {0;0;0}, f = {f0[0];f0[1];f0[2]}*cos(w[i]t), w[i] = 3.5, f0[i] = 2.0
NSTEP = 20, DELT = 0.1

```

```

*/
#include <iostream.h>
#include <stdlib.h>
#include <iomanip.h>
#include <math.h>

void modal(double **, double *, double *, double *, double *, double *, double *, double *, double *)
{
    double **, double **, double, double **, double **, double **, double **, double **,
    double **, double **, int, int, int);
void matmul(double **, double **, double **, int, int, int);

int main()
{
    int n, nvec, nstep, i, j, k;
    double delt, time;
    double **xm, *cm, *z, *x0, *xd0, *y0, *yd0, **ev, **evt, **xmx, **xtmx, *t, **f,
    **x, **u, **v, **q, *cmf, *f0;

    cout << "Please input N, NVEC and NSTEP:" << endl;
    cin >> n >> nvec >> nstep;
    cout << endl << "please input delt" << endl;
    cin >> delt;

    xm = new double* [n];
    cm = new double[nvec];
    cmf = new double[n];
    f0 = new double[n];
    z = new double[nvec];
    x0 = new double[n];
    xd0 = new double[n];
    y0 = new double[nvec];
    yd0 = new double[nvec];
    ev = new double* [n];
    evt = new double* [nvec];
    xmx = new double* [n];
    xtmx = new double* [nvec];
    t = new double[nstep];
    f = new double* [n];
    x = new double* [n];
    u = new double* [nvec];
    v = new double* [nvec];

```

```

q = new double* [nvec];
for (i = 0; i < n; i ++)
{
    xm[i] = new double[n];
    ev[i] = new double[nvec];
    xmx[i] = new double[nvec];
    x[i] = new double[nstep];
    f[i] = new double[nstep];
}

for (i = 0; i < nvec; i++)
{
    evt[i] = new double[n];
    xtmx[i] = new double[nvec];
    u[i] = new double[nstep];
    v[i] = new double[nstep];
    q[i] = new double[nstep];
}
cout << endl << "Please input omf:" << endl;
for (i = 0; i < n; i ++)
{
    cin >> omf[i];
}

cout << endl << "Please input f0:" << endl;
for (i = 0; i < n; i ++)
{
    cin >> f0[i];
}

cout << endl << "Please input mass matrix xm row by row:" << endl;
for (i = 0; i < n; i ++)
{
    for (j = 0; j < n; j++)
        cin >> xm[i][j];
}
cout << endl << "Please input matrix ev row by row:" << endl;
for (i = 0; i < n; i ++)
{
    for (j = 0; j < nvec; j++)
        cin >> ev[i][j];
}
cout << endl << "Please input array cm:" << endl;
for (i = 0; i < nvec; i ++)
    cin >> cm[i];
for (i = 0; i < n; i++)
{
    x0[i] = 0.0;
    xd0[i] = 0.0;
}

for(i = 0; i < nvec; i++)
    z[i] = 0.001;

for(i = 0; i < nstep; i++)
{
    time = double(i+1) * delt;
    f[0][i] = f0[0] * cos(omf[0] * time);
    f[1][i] = f0[1] * cos(omf[1] * time);
    f[2][i] = f0[2] * cos(omf[2] * time);
}

for (i = 0; i < nvec; i ++)
{
    for (j = 0; j < n; j++)
        evt[i][j] = ev[j][i];
}

modal(xm, cm, omf, t, z, x0, xd0, y0, yd0, q, f, delt, ev, evt, xmx, xtmx,
    x, u, v, nstep, n, nvec);

cout << endl << "RESPONSE OF SYSTEM USING MODAL ANALYSIS" << endl << endl;
for (i = 0; i < n; i ++)
{
    cout << endl << "COORDINATE" << setw(6) << setiosflags(ios::right) << i+1 << endl;

    for (k = 0; k < 60; k ++)

    {
        for (j = 0; j < nstep/60; j ++)
        {
            cout << setprecision(6) << setiosflags(ios::fixed | ios::showpoint)
                << setw(12) << setiosflags(ios::right) << x[i][{(nstep/60)*k + j}];
        }
        cout << endl;
    }
}

cout << endl;
}

```

```

delete []cm;
delete []t;
delete []z;
delete []cmf;
delete []f0;
delete []x0;
delete []xd0;
delete []y0;
delete []yd0;

for (i = 0; i < n; i++)
{
    delete []x[i];
    delete []ev[i];
    delete []xmx[i];
    delete []xm[i];
    delete []f[i];
}

for (i = 0; i < nvec; i++)
{
    delete []q[i];
    delete []evt[i];
    delete []xtmx[i];
    delete []u[i];
    delete []v[i];
}

delete []x;
delete []ev;
delete []xmx;
delete []xm;
delete []f;
delete []q;
delete []evt;
delete []xtmx;
delete []u;
delete []v;

return 0;
}

void modal(double **xm, double *cm, double *cmf, double *t, double *z, double *x0, double *xd0,
double *y0, double *yd0, double **q, double **f, double delt, double **ev,
double **evt, double **xmx, double **xtmx, double **x, double **u, double **v,
int nstep, int n, int nvec)
{
    int i, j;
    double r, pp, qq, zi, omeg, cmd, c1, c2, c3, c4, c5, c6;

    t[0] = delt;
    for (i = 1; i < nstep; i++)
        t[i] = t[i-1] + delt;

    // normalization of modal matrix with respect to the mass matrix

    matmul(xmx, xm, ev, n, n, nvec);
    matmul(xtmx, evt, xmx, nvec, n, nvec);
    for (i = 0; i < nvec; i++)
    {
        for (j = 0; j < n; j++)
            ev[j][i] = ev[j][i] / sqrt(xtmx[i][i]);
    }

    // conversion of informaton to normal coordinates
    for (i = 0; i < nvec; i++)
    {
        y0[i] = 0.0;
        yd0[i] = 0.0;
    }

    for (i = 0; i < nvec; i++)
    {
        for (j = 0; j < n; j++)
        {
            y0[i] = y0[i] + ev[j][i] * xd0[j];
            yd0[i] = yd0[i] + ev[j][i] * xd0[j];
        }
    }

    for (i = 0; i < nvec; i++)
    {
        for (j = 0; j < n; j++)
            evt[i][j] = ev[j][i];
    }

    matmul(q, evt, f, nvec, n, nstep);

    for (i = 0; i < nvec; i++)

```

```

    r = omf[i] / om[i];
    pp = y0[i];
    qq = yd0[i];
    zi = z[i];
    omeg = om[i];
    omd = omeg * sqrt(1.0 - zi * zi);
    for (j = 0; j < nstep; j++)
    {
        if (j != 0)
        {
            pp = u[i][j-1];
            qq = v[i][j-1];
        }
        c1 = exp(-zi * omeg * delt);
        c2 = cos(omd * delt);
        c3 = sin(omd * delt);
        c4 = (qq + omeg * zi * pp) / omd;
        c5 = omeg * zi / omd;
        c6 = q[i][j] / (omeg * omeg);
        u[i][j] = c1 * (pp * c2 + c3 * c4) + c6 * (1.0 - c1 * (c2 + c3 * c5));
        v[i][j] = omd * c1 * (-pp * c3 + c2 * c4 - c5 * (pp * c2 + c3 * c4))
            + c6 * omd * c1 * c3 * (1.0 + c5 * c5);
    }
}

matmul(x, ev, u, n, nvec, nstep);
return;
}

void matmul(double **a, double **b, double **c, int l, int m, int n)
{
    int i, j, k;
    for (i = 0; i < l; i++)
    {
        for (j = 0; j < n; j++)
        {
            a[i][j] = 0.0;
            for (k = 0; k < m; k++)
                a[i][j] = a[i][j] + b[i][k]*c[k][j];
        }
    }
    return;
}

```

6.95

```

C =====
C
C PROGRAM 7.F
C MAIN PROGRAM WHICH CALLS POLCOF
C
C =====
C FOLLOWING 4 LINES CONTAIN PROBLEM-DEPENDENT DATA
    DIMENSION A(3,3),B(3,3),C(3,3),P(3),S(3),PCF(4)
    N=3
    NP=4
    DATA A/5.0,3.0,1.0,3.0,6.0,2.0,2.0,4.0,6.0/
C END OF PROBLEM-DEPENDENT DATA
    CALL POLCOF (A,B,C,P,S,PCF,N,NP)
    PRINT 10
10  FORMAT (//,49H POLYNOMIAL EXPANSION OF A DETERMINANTAL EQUATION)
    PRINT 20
20  FORMAT (//,21H DATA: DETERMINANT A: ,/)
    DO 30 I=1,N
30  PRINT 40, (A(I,J),J=1,N)
40  FORMAT (4E15.6)
    PRINT 50
50  FORMAT (/,35H RESULT: POLYNOMIAL COEFFICIENTS IN,/,
2  53H PCF(NP)*(X**N)+PCF(N)*(X**N-1)+...+PCF(2)*X+PCF(1)=0,/)
    PRINT 60, (PCF(I),I=1,NP)
60  FORMAT (4E15.6)
    STOP
    END
C =====
C
C SUBROUTINE POLCOF
C
C =====
    SUBROUTINE POLCOF (A,B,C,P,S,PCF,N,NP)
    DIMENSION A(N,N),B(N,N),C(N,N),P(N),S(N),PCF(NP)

```

```

      DO 10 I=1,N
      P(I)=0.0
      DO 10 J=1,N
10     B(I,J)=0.0
      DO 20 J=1,N
20     B(J,J)=1.0
      DO 60 K=1,N
      S(K)=0.0
      DO 30 I=1,N
      DO 30 J=1,N
30     C(I,J)=B(I,J)
      CALL MATMUL (B,C,A,N,N,N)
      DO 40 J=1,N
40     S(K)=S(K)+B(J,J)
      P(1)=-S(1)
      IF (K .EQ. 1) GO TO 60
      KM=K-1
      DO 50 I=1,KM
50     P(K)=P(K) - (1.0/FLOAT(K)) * (S(I)*P(K-I))
      P(K)=P(K) - S(K)/FLOAT(K)
60     CONTINUE
      DO 70 I=1,N
70     PCF(I)=P(NP-I)
      PCF(NP)=1.0
      RETURN
      END

```

```

C =====
C
C SUBROUTINE MATMUL
C
C =====
C MATRIX MULTIPLICATION SUBROUTINE: A = B * C
C B(L,M) AND C(M,N) ARE INPUT MATRICES, A(L,N) IS OUTPUT MATRIX
  SUBROUTINE MATMUL (A,B,C,L,M,N)
    DIMENSION A(L,N),B(L,M),C(M,N)
    DO 10 I=1,L
    DO 10 J=1,N
      A(I,J)=0.0
    DO 10 K=1,M
10     A(I,J)=A(I,J)+B(I,K)*C(K,J)
    RETURN
    END

```

POLYNOMIAL EXPANSION OF A DETERMINANTAL EQUATION

DATA: DETERMINANT A:

0.500000E+01	0.300000E+01	0.200000E+01
0.300000E+01	0.600000E+01	0.400000E+01
0.100000E+01	0.200000E+01	0.600000E+01

RESULT: POLYNOMIAL COEFFICIENTS IN

$PCF(NP) * (X^{**N}) + PCF(N) * (X^{**N-1}) + \dots + PCF(2) * X + PCF(1) = 0$

-0.980000E+02	0.770000E+02	-0.170000E+02	0.100000E+01
---------------	--------------	---------------	--------------

6.96

```

C =====
C
C PROGRAM 8.F
C MAIN PROGRAM FOR CALLING THE SUBROUTINE MODAL
C
C =====
      DIMENSION XM(3,3),OM(3),Z(3),X0(3),XD0(3),Y0(3),YD0(3),EV(3,3),
2  EVT(3,3),XMX(3,3),XTMX(3,3),T(30),F(3,30),X(3,30),U(3,30),
3  V(3,30),Q(3,30)
4  ,OMF(3)
      DATA N,NVEC,NSTEP,DELT/3,3,30,0.1/
      DATA XM/41.4,0.0,0.0,0.0,38.8,0.0,0.0,0.0,25.88/
      DATA OMF/5.0,10.0,20.0/
      DATA OM/25.076, 53.578,110.907/
      DATA Z/0.001,0.001,0.001/
      DATA X0/0.0,0.0,0.0/
      DATA XD0/0.0,0.0,0.0/
      DATA EV/1.0,1.303,1.947,1.0,0.860,-1.685,1.0,-1.0,0.183/
      DO 5 I=1,NSTEP
      TIME=REAL(I)*DELT
      F(1,I)=5000.0*COS(OMF(1)*TIME)
      F(2,I)=10000.0*COS(OMF(2)*TIME)
5     F(3,I)=20000.0*COS(OMF(3)*TIME)
      DO 20 I=1,NVEC
      DO 20 J=1,N
20     EVT(I,J)=EV(J,I)
      CALL MODAL (XM,OM,OMF,T,Z,X0,XD0,Y0,YD0,Q,F,DELT,EV,EVT,XMX,
2     XTMX,X,U,V,NSTEP,N,NVEC)
      PRINT 30
30     FORMAT (//,40H RESPONSE OF SYSTEM USING MODAL ANALYSIS,/)
      DO 40 I=1,N
40     PRINT 50,I,(X(I,J),J=1,NSTEP)
50     FORMAT (/,11H COORDINATE,I5,/, (1X,5E14.6))
      STOP
      END
C =====
C
C SUBROUTINE MODAL
C
C =====
      SUBROUTINE MODAL (XM,OM,OMF,T,Z,X0,XD0,Y0,YD0,Q,F,DELT,EV,EVT,
2     XMX,XTMX,X,U,V,NSTEP,N,NVEC)
      DIMENSION XM(N,N),OM(NVEC),T(NSTEP),Z(NVEC),X0(N),XD0(N),
2     Y0(NVEC),YD0(NVEC),Q(NVEC,NSTEP),F(N,NSTEP),EV(N,NVEC),
3     EVT(NVEC,N),XMX(N,NVEC),XTMX(NVEC,NVEC),X(N,NSTEP),U(NVEC,
4     NSTEP),V(NVEC,NSTEP)
5     ,OMF(N)
      T(1)=DELT
      DO 10 I=2,NSTEP
10     T(I)=T(I-1)+DELT
C NORMALIZATION OF MODAL MATRIX WITH RESPECT TO THE MASS MATRIX
      CALL MATMUL (XMX,XM,EV,N,N,NVEC)
      CALL MATMUL (XTMX,EVT,XMX,NVEC,N,NVEC)
      DO 30 I=1,NVEC
      DO 20 J=1,N
20     EV(J,I)=EV(J,I)/SQRT(XTMX(I,I))
30     CONTINUE
C CONVERSION OF INFORMATION TO NORMAL COORDINATES
      DO 40 I=1,NVEC
      Y0(I)=0.0
40     YD0(I)=0.0
      DO 60 I=1,NVEC
      DO 50 J=1,N
      Y0(I)=Y0(I)+EV(J,I)*X0(J)
50     YD0(I)=YD0(I)+EV(J,I)*XD0(J)
60     CONTINUE
      DO 70 I=1,NVEC
      DO 70 J=1,N
70     EVT(I,J)=EV(J,I)
      CALL MATMUL (Q,EVT,F,NVEC,N,NSTEP)

```

```

DO 100 I=1,NVEC
R=OMF(I)/OM(I)
PP=Y0(I)
QQ=YD0(I)
ZI=Z(I)
OMEG=OM(I)
OMD=OMEG*SQRT(1.0-ZI**2)
DO 90 J=1,NSTEP
IF (J .EQ. 1) GO TO 80
PP=U(I,J-1)
QQ=V(I,J-1)
80 C1=EXP(-ZI*OMEG*DELT)
C2=COS(OMD*DELT)
C3=SIN(OMD*DELT)
C4=(QQ+OMEG*ZI*PP)/OMD
C5=OMEG*ZI/OMD
C6=Q(I,J)/(OMEG**2)
U(I,J)=C1*(PP*C2+C3*C4)+C6*(1.0-C1*(C2+C3*C5))
V(I,J)=OMD*C1*(-PP*C3+C2*C4-C5*(PP*C2+C3*C4))+C6*OMD*C1*C3*
2 (1.0+C5**2)
90 CONTINUE
100 CONTINUE
C FINDING THE SOLUTION IN THE ORIGINAL COORDINATES
CALL MATMUL (X,EV,U,N,NVEC,NSTEP)
RETURN
END

```

```

C =====
C
C SUBROUTINE MATMUL
C
C =====
C MATRIX MULTIPLICATION SUBROUTINE: A = B * C
C B(L,M) AND C(M,N) ARE INPUT MATRICES, A(L,N) IS OUTPUT MATRIX
SUBROUTINE MATMUL (A,B,C,L,M,N)
DIMENSION A(L,N),B(L,M),C(M,N)
DO 10 I=1,L
DO 10 J=1,N
A(I,J)=0.0
DO 10 K=1,M
10 A(I,J)=A(I,J)+B(I,K)*C(K,J)
RETURN
END

```

RESPONSE OF SYSTEM USING MODAL ANALYSIS

```

COORDINATE 1
-0.464810E-01 -0.281889E+00 0.647861E+00 -0.516883E+00 -0.619579E+00
0.130776E+01 -0.102870E+01 -0.837508E-01 0.100628E+01 -0.103089E+01
0.206455E+00 0.402444E+00 0.523450E-02 -0.193166E+00 0.156882E+00
0.535653E+00 -0.124196E+01 0.554321E+00 0.468392E+00 -0.127719E+01
0.108567E+01 0.547941E-02 -0.743677E+00 0.519931E+00 0.652021E-01
-0.982506E-02 -0.278357E+00 0.769791E+00 -0.326540E+00 -0.892837E+00

```

```

COORDINATE 2
-0.652229E-01 -0.401249E+00 0.782121E+00 -0.688138E+00 -0.719795E+00
0.181845E+01 -0.132434E+01 -0.196819E+00 0.123485E+01 -0.133215E+01
0.327264E+00 0.557237E+00 -0.663155E-02 -0.300626E+00 0.132372E+00
0.648688E+00 -0.157278E+01 0.856773E+00 0.710609E+00 -0.170227E+01
0.128876E+01 -0.662384E-01 -0.929877E+00 0.763235E+00 0.127997E+00
-0.413525E-01 -0.444138E+00 0.911875E+00 -0.452567E+00 -0.107113E+01

```

```

COORDINATE 3
-0.168211E+00 -0.803460E+00 0.107799E+01 -0.818669E+00 -0.843998E+00
0.278795E+01 -0.201096E+01 -0.487560E+00 0.162661E+01 -0.191215E+01
0.762385E+00 0.992008E+00 -0.569407E-01 -0.754704E+00 -0.186120E+00
0.970877E+00 -0.195164E+01 0.164283E+01 0.118810E+01 -0.271367E+01
0.149501E+00 -0.358931E+00 -0.118424E+01 0.153441E+01 0.444169E+00
-0.143291E+00 -0.114794E+01 0.907985E+00 -0.589494E+00 -0.112923E+01

```

6.97

```

C =====
C
C SOLUTION OF PROBLEM 6.97
C
C =====
C

```

```

C N      = NUMBER OF DEGREES OF FREEDOM OF THE SYSTEM
C NM     = N-1
C XK(N,N) = STIFFNESS MATRIX
C XM(N,N) = MASS MATRIX
C OM(N)   = VECTOR OF NATURAL FREQUENCIES
C X(N,N)  = MATRIX OF EIGENVECTORS, J TH EIGENVECTOR IS STORED IN THE
C          J TH COLUMN OF THE MATRIX X
C DIMENSIONS OF OTHER MATRICES: A(NM,NM),B(NM),LA(NM),LB(NM,2),S(NM)
C

```

```

DIMENSION XK(3,3),XM(3,3),OM(3),X(3,3),A(2,2),B(2),LA(2),LB(2,2),
2 S(2)

```

```
DATA XK/2.,-1.,0.,-1.,2.,-1.,0.,-1.,2./
```

```
DATA XM/2.,0.,0.,0.,3.,0.,0.,0.,2./
```

```
DATA OM/.482087,1.,1.197605/
```

```
N=3
```

```
NM=N-1
```

```
IND=1
```

```
DO 10 I=1,N
```

```
DO 20 J=1,NM
```

```
DO 20 K=1,NM
```

```
A(J,K)=XK(J,K+1)-(OM(I)**2)*XM(J,K+1)
```

```
20 B(J)=-XK(J,1)+(OM(I)**2)*XM(J,1)
```

```
CALL SIMUL (A,B,NM,IND,LA,LB,S)
```

```
X(1,I)=1,0
```

```
DO 30 J=1,NM
```

```
30 X(J+1,I)=B(J)
```

```
*WRITE (44,110) OM(I),(X(J,I),J=1,N)
```

```
110 FORMAT (//2X,19H NATURAL FREQUENCY=,E15.8,/,2X,13H EIGENVECTOR=,
2 /,(2X,4E11.8))
```

```
10 CONTINUE
```

```
STOP
```

```
END
```

```
NATURAL FREQUENCY= 0.48208699E+00
```

```
EIGENVECTOR=
```

```
0.10000000E+01 0.15351844E+01 0.10000019E+01
```

```
NATURAL FREQUENCY= 0.10000000E+01
```

```
EIGENVECTOR=
```

```
0.10000000E+01 0.00000000E+00-0.10000000E+01
```

```
NATURAL FREQUENCY= 0.11976050E+01
```

```
EIGENVECTOR=
```

```
0.10000000E+01-0.86851549E+00 0.99999440E+00
```

6.98

```

C
C PROBLEM 6.98
C

```

```

C =====
C N      = NUMBER OF DEGREES OF FREEDOM OF THE SYSTEM
C XM(N,N)= MASS MATRIX
C X(N,N) = MATRIX CONTAINING THE ORIGINAL I TH NORMAL MODE IN I TH
C          COLUMN
C XN(N,N)= MATRIX CONTAINING THE [M]-ORTHONORMAL I TH NORMAL MODE
C          IN I TH COLUMN
C DIMENSIONS OF OTHER VECTORS: A(N),B(N)
C   DIMENSION XM(3,3),X(3,3),XN(3,3),A(3),B(3)
C   N=3
C   DATA X4 /1.0,0.0,0.0,0.0,2.0,0.0,0.0,0.0,1.0/
C   DATA X  /1.0,-1.0,1.0,1.0,1.0,1.0,0.0,1.0,2.0/
C   DO 10 I=1,N
C   DO 20 J=1,N
20  A(J)=X(J,I)
C   CALL MULT (XM,A,B,N)
C   SUM=0.0
C   DO 30 K=1,N
30  SUM=SUM+X(K,I)*B(K)
C   SUM=SQRT(1.0/SUM)
C   DO 40 K=1,N
40  XN(K,I)=X(K,I)*SUM
C   PRINT 50, I,(XN(J,I),J=1,N)
50  FORMAT (/,2X,13H EIGENVECTOR: ,15,/,2X,(4E15.8))
10  CONTINUE
C   STOP
C   END

```

```

C =====
C
C SUBROUTINE MULT
C

```

```

C =====
C   SUBROUTINE MULT (XM,A,B,N)
C   DIMENSION XM(N,N),A(N),B(N)
C   DO 10 I=1,N
C   B(I)=0.0
C   DO 20 J=1,N
20  H(I)=B(I)+XM(I,J)*A(J)
10  CONTINUE
C   RETURN
C   END

```

```

EIGENVECTOR:    1
0.50000000E+00 0.50000000E+00 0.50000000E+00

```

```

EIGENVECTOR:    2
0.50000000E+00 0.50000000E+00 0.50000000E+00

```

```

EIGENVECTOR:    3
0.00000000E+00 0.40824831E+00 0.81649661E+00

```

6.99

The main program and results are shown below.

```

C =====
C MAIN PROGRAM FOR CALLING THE SUBROUTINE MODAL
C =====
C
      DIMENSION XM(3,3),OM(3),Z(3),X0(3),XDO(3),Y0(3),YDO(3),EV(3,3),
2  EVT(3,3),XMX(3,3),XIMX(3,3),T(40),F(3,40),X(3,40),U(3,40),
3  V(3,40),Q(3,40)
      DATA N,NVEC,NSTEP,DELT/3,3,40,0.1/
      DATA XM/2.0,0.0,0.0,0.0,2.0,0.0,0.0,0.0,2.0/
      DMF=5.0
      DATA OM/1.530734,2.828428,3.695518/
      DATA Z/0.0,0.0,0.0/
      DATA X0/0.0,0.0,0.0/
      DATA XDO/0.0,0.0,0.0/
      DATA (EV(I,1),I=1,3)/1.0,1.414214,1.0/
      DATA (EV(I,2),I=1,3)/1.0,0.0,-1.0/
      DATA (EV(I,3),I=1,3)/1.0,-1.414214,1.0/
      DO 5 I=1,NSTEP
      TIME=REAL(I)*DELT
5  F(1,I)=10.0*SIN(5.0*TIME)
      DO 10 I=1,NSTEP
      F(2,I)=0.0
10  F(3,I)=0.0
      DO 20 I=1,NVEC
      DO 20 J=1,N
20  EVT(I,J)=EV(J,I)
      CALL MODAL (XM,OM,DMF,T,Z,X0,XDO,Y0,YDO,Q,F,DELT,EV,EVT,XMX,
2  XIMX,X,U,V,NSTEP,N,NVEC)
      WRITE (29,30)
30  FORMAT (//,40H RESPONSE OF SYSTEM USING MODAL ANALYSIS,/)
      DO 40 I=1,N
40  WRITE (29,50) I,(X(I,J),J=1,NSTEP)
50  FORMAT (/,11H COORDINATE,15,/, (1X,5E14.6))
      STOP
      END

```

RESPONSE OF SYSTEM USING MODAL ANALYSIS

COORDINATE 1

0.119060E-01	0.556720E-01	0.140716E+00	0.262090E+00	0.400585E+00
0.526842E+00	0.608511E+00	0.618689E+00	0.543493E+00	0.386804E+00
0.170858E+00	-0.676210E-01	-0.284971E+00	-0.440109E+00	-0.503791E+00
-0.465406E+00	-0.335646E+00	-0.144346E+00	0.660445E-01	0.249893E+00
0.368518E+00	0.398672E+00	0.337414E+00	0.202231E+00	0.264541E-01
-0.148937E+00	-0.285117E+00	-0.354495E+00	-0.346914E+00	-0.271541E+00
-0.154034E+00	-0.297635E-01	0.652391E-01	0.103369E+00	0.723514E-01
-0.216811E-01	-0.155688E+00	-0.295363E+00	-0.403527E+00	-0.449197E+00

COORDINATE 2

0.397433E-04	0.655754E-03	0.356972E-02	0.119145E-01	0.297943E-01
0.612223E-01	0.108686E+00	0.171738E+00	0.246047E+00	0.323279E+00
0.391991E+00	0.439459E+00	0.454134E+00	0.428213E+00	0.359732E+00
0.253658E+00	0.121640E+00	-0.196366E-01	-0.151233E+00	-0.255357E+00
-0.318689E+00	-0.334940E+00	-0.306091E+00	-0.242021E+00	-0.158585E+00
-0.745270E-01	-0.794475E-02	0.276338E-01	0.247827E-01	-0.156785E-01
-0.856190E-01	-0.171361E+00	-0.256531E+00	-0.325272E+00	-0.365137E+00
-0.369097E+00	-0.336327E+00	-0.271711E+00	-0.184302E+00	-0.851769E-01

COORDINATE 3

0.526197E-07	0.338722E-05	0.398979E-04	0.232946E-03	0.912614E-03
0.274891E-02	0.685317E-02	0.147839E-01	0.284018E-01	0.495493E-01
0.795763E-01	0.118784E+00	0.165904E+00	0.217719E+00	0.269161E+00

```

0.313352E+00  0.342632E+00  0.349486E+00  0.327819E+00  0.274185E+00
0.188751E+00  0.758134E-01 -0.563065E-01 -0.195996E+00 -0.329661E+00
-0.443429E+00 -0.524977E+00 -0.565224E+00 -0.559583E+00 -0.508616E+00
-0.417951E+00 -0.297528E+00 -0.160267E+00 -0.204086E-01  0.108245E+00
0.213908E+00  0.288030E+00  0.326005E+00  0.327354E+00  0.295404E+00

```

6.100 The main program used to generate the numerical results and the graph are given.

```

C =====
C
C MAIN PROGRAM FOR CALLING THE SUBROUTINE MODAL
C
C =====
C
  DIMENSION XM(3,3),OM(3),Z(3),X0(3),XDO(3),Y0(3),YDO(3),EV(3,3),
2  EVT(3,3),XMX(3,3),XTMX(3,3),T(40),F(3,40),X(3,40),U(3,40),
3  V(3,40),Q(3,40)
  DATA N,NVEC,NSTEP,DELT/3,3,40,0.1/
  DATA XM/2.0,0.0,0.0,0.0,2.0,0.0,0.0,0.0,2.0/
  DATA OM/1.530734,2.828428,3.695518/
  DATA Z/0.0,0.0,0.0/
  DATA X0/0.0,0.0,0.0/
  DATA XDO/0.0,0.0,0.0/
  DATA (EV(I,1),I=1,3)/1.0,1.414214,1.0/
  DATA (EV(I,2),I=1,3)/1.0,0.0,-1.0/
  DATA (EV(I,3),I=1,3)/1.0,-1.414214,1.0/
  OMF=0.0
  DO 55 IJK=1,10
  OMF=OMF+1.0
  DO 5 I=1,NSTEP
  TIME=REAL(I)*DELT
  F(1,I)=10.0*SIN(OMF*TIME)
  DO 10 I=1,NSTEP
  F(2,I)=0.0
  DO 20 I=1,NVEC
  DO 20 J=1,N
  EVT(I,J)=EV(J,I)
  CALL MODAL (XM,OM,OMF,T,Z,X0,XDO,Y0,YDO,O,F,DELT,EV,EVT,XMX,
2  XTMX,X,U,V,NSTEP,N,NVEC)
  WRITE (29,30)
  DO 40 I=1,N
  WRITE (29,50) I,(X(I,J),J=1,NSTEP)
  DO 50 I=1,N
  WRITE (29,50) I,(X(I,J),J=1,NSTEP)
  FORMAT (/,40H RESPONSE OF SYSTEM USING MODAL ANALYSIS,/)
  DO 40 I=1,N
  WRITE (29,50) I,(X(I,J),J=1,NSTEP)
  FORMAT (/,11H COORDINATE,IS,/, (1X,5E14.6))
  CONTINUE
  STOP
  END

```

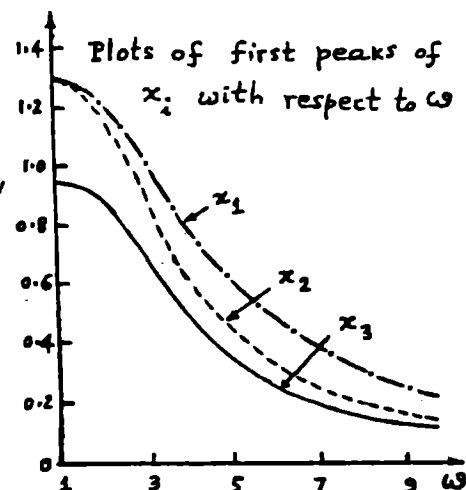

- 6.101** (a) $k_1 = 900 \text{ kN/m}$, $k_2 = 900 \text{ kN/m}$, $k_3 = 3.5 \text{ MN/m}$,
 $c_1 = c_2 = c_3 = 2000 \text{ N} \cdot \text{s/m}$, $m_f = 9000 \text{ kg}$, $m_b = 2000 \text{ kg}$, $m_h = 400 \text{ kg}$,
 $F(t) = 200 \cos 60 t \text{ (N)}$

Solution:

(a) Equation of motion:

$$\begin{bmatrix} m_f & 0 & 0 \\ 0 & m_b & 0 \\ 0 & 0 & m_h \end{bmatrix} \begin{Bmatrix} \ddot{x}_1 \\ \ddot{x}_2 \\ \ddot{x}_3 \end{Bmatrix} + \begin{bmatrix} c_1 + c_2 & -c_2 & 0 \\ -c_2 & c_2 + c_3 & -c_3 \\ 0 & -c_3 & c_3 \end{bmatrix} \begin{Bmatrix} \dot{x}_1 \\ \dot{x}_2 \\ \dot{x}_3 \end{Bmatrix} + \begin{bmatrix} k_1 + k_2 & -k_2 & 0 \\ -k_2 & k_2 + k_3 & -k_3 \\ 0 & -k_3 & k_3 \end{bmatrix} \begin{Bmatrix} x_1 \\ x_2 \\ x_3 \end{Bmatrix} = \begin{Bmatrix} 0 \\ 0 \\ F_3(t) \end{Bmatrix}$$

Forcing function can be written as

$$F_3(t) = \text{Re}(F_0 e^{i\omega t}) = F_{30} \cos \omega t = 200 \cos 60 t \text{ (N)} \quad (\text{E}_1)$$

Steady-state solution can be assumed as

$$X_j(t) = X_j e^{i\omega t}, j = 1, 2, 3 \quad (\text{E}_2)$$

Equations of motion become

$$\begin{bmatrix} -m_f \omega^2 + (c_1 + c_2) i \omega + k_1 + k_2 & -c_2 i \omega - k_2 & 0 \\ -c_2 i \omega - k_2 & -m_b \omega^2 + (c_2 + c_3) i \omega + k_2 + k_3 & -c_3 i \omega - k_3 \\ 0 & -c_3 i \omega - k_3 & -m_h \omega^2 + c_3 i \omega + k_3 \end{bmatrix} \begin{Bmatrix} X_1 \\ X_2 \\ X_3 \end{Bmatrix} = \begin{Bmatrix} 0 \\ 0 \\ F_{30} \end{Bmatrix} \quad (\text{E}_3)$$

For known data, Eq. (E₃) becomes

$$[Z_{ij}] \bar{X} = \bar{F}_0 \quad (\text{E}_4)$$

where

$$\begin{aligned} Z_{11} &= -9000 \omega^2 + i 4000 \omega + 1.8 \times 10^6 = -30.6 \times 10^6 + i 0.24 \times 10^6 \\ Z_{12} &= Z_{21} = -i 2000 \omega - 900 \times 10^3 = -900 \times 10^3 - i 120 \times 10^3 \\ Z_{13} &= Z_{31} = 0 \\ Z_{22} &= -2000 \omega^2 + i 4000 \omega + 4.4 \times 10^6 = -2.8 \times 10^6 + i 0.24 \times 10^6 \\ Z_{23} &= Z_{32} = -i 2000 \omega - 3.5 \times 10^6 = -3.5 \times 10^6 - i 120 \times 10^3 \\ Z_{33} &= -400 \omega^2 + i 2000 \omega + 3.5 \times 10^6 = 2.06 \times 10^6 + i 0.12 \times 10^6 \end{aligned} \quad (\text{E}_5)$$

Solution of Eq. (E₄) can be expressed as

$$\bar{X} = [Z_{ij}]^{-1} \bar{F}_0 \quad (E_6)$$

Using Cramer's rule, we get

$$X_1 = \begin{vmatrix} 0 & Z_{12} & Z_{13} \\ 0 & Z_{22} & Z_{23} \\ F_{30} & Z_{32} & Z_{33} \end{vmatrix} \cdot \frac{1}{\det [Z_{ij}]} = (0.0114 \times 10^{-4} + i 0.0016 \times 10^{-4})$$

$$X_2 = \begin{vmatrix} Z_{11} & 0 & Z_{13} \\ Z_{21} & 0 & Z_{23} \\ Z_{31} & F_{30} & Z_{33} \end{vmatrix} \cdot \frac{1}{\det [Z_{ij}]} = (-0.3893 + i 0.0010) \times 10^{-4}$$

$$X_3 = \begin{vmatrix} Z_{11} & Z_{12} & 0 \\ Z_{21} & Z_{22} & 0 \\ Z_{31} & Z_{32} & F_{30} \end{vmatrix} \cdot \frac{1}{\det [Z_{ij}]} = (0.3071 - i 0.0388) \times 10^{-4}$$

$$\begin{aligned} \therefore x_1(t) &= X_1 (\cos 60 t + i \sin 60 t) \\ &= (0.0114 \cos 60 t - 0.0016 \sin 60 t) \times 10^{-4} \\ &\quad + i (0.0016 \cos 60 t + 0.0114 \sin 60 t) \times 10^{-4} \end{aligned}$$

$$\begin{aligned} \text{Actual response of } m_f &= \text{Real } [x_1(t)] \\ &= (0.0114 \cos 60 t - 0.0016 \sin 60 t) \times 10^{-4} \text{ m} \end{aligned}$$

Similarly, we find

$$\begin{aligned} \text{Actual response of } m_b &= \text{Real } [x_2(t)] \\ &= (-0.3893 \cos 60 t - 0.0010 \sin 60 t) \times 10^{-4} \text{ m} \end{aligned}$$

$$\begin{aligned} \text{Actual response of } m_c &= \text{Real } [x_3(t)] \\ &= (0.3071 \cos 60 t - 0.0388 \sin 60 t) \times 10^{-4} \text{ m} \end{aligned}$$

- (b) Change the stiffness k_2 from 900 kN/m in increments of 500 kN/m, and find the response of the tool head (x_3) using the procedure outlined in part (a). Find the value of k_2 for which the maximum response of x_3 is 25% lower than the value found in part (a).
- (c) Change the values of c_1 , c_2 , c_3 , k_1 and k_3 individually and find whether any of these quantities can be used to achieve the goal of part (b).
-