

SURFACE TRANSPORTATION

<i>AUTOMOBILE AIR CONDITIONING</i>	9.1	<i>Ventilation and Thermal Comfort</i>	9.9
<i>Design Factors</i>	9.1	<i>Thermal Load Analysis</i>	9.9
<i>Air-Handling Subsystem</i>	9.2	<i>Bus Air Conditioning</i>	9.9
<i>Heating Subsystem</i>	9.5	<i>Rail Car Air Conditioning</i>	9.11
<i>Refrigeration Subsystem</i>	9.5	<i>Fixed-Guideway Vehicle Air</i>	
<i>MASS-TRANSIT AIR CONDITIONING</i>	9.8	<i>Conditioning</i>	9.13

AUTOMOBILE AIR CONDITIONING

ENVIRONMENTAL control in modern automobiles usually consists of one (or two for large cars, trucks, and sport utility vehicles) in-cabin air-handling unit that performs the following functions: (1) heating, (2) defrosting, (3) ventilation, and (4) cooling and dehumidifying (air conditioning). This unit is accompanied by an underhood vapor cycle compressor, condenser, and expansion device. The basic system can be divided into three subsystems: air handling, heating, and refrigeration (cooling). All passenger cars sold in the United States must meet federal defroster requirements, so ventilation systems and heaters are included in the basic vehicle design. The most common system today integrates the defroster, heater, and ventilation system. In the United States, the vast majority of vehicles sold today are equipped with air conditioning as original equipment.

DESIGN FACTORS

General considerations for design include ambient temperatures and humidity, operational environment of components, airborne contaminants, vehicle and engine concessions, physical parameters, durability, electrical power consumption, cooling capacity, occupants, infiltration, insulation, solar effect, vehicle usage profile, noise, and vibration, as described in the following sections.

Cooling Load Factors

Occupancy. Occupancy per unit volume is high in automotive applications. The air conditioner (and auxiliary evaporators and systems) must be matched to the intended vehicle occupancy.

Infiltration. Like buildings, automobiles are not completely sealed: wiring harnesses, fasteners, and many other items must penetrate the cabin. Infiltration varies with relative wind-vehicle velocity. Unlike buildings, automobiles are intended to create a relative wind speed, and engines may emit gases other than air. Body sealing and body relief vents are part of air-conditioning design for automobiles. Occasionally, sealing beyond that required for dust, noise, and draft control is required.

Insulation. Because of cost and weight considerations, insulation is seldom added to reduce thermal load; insulation for sound control is generally considered adequate. Additional dashboard and floor thermal insulation helps reduce cooling load. Typical interior maximum temperatures are 200°F above mufflers and catalytic converters, 120°F for other floor areas, 145°F for dash and toe board, and 110°F for sides and top.

Solar Effects. The following three solar effects add to the cooling load:

- **Vertical.** Maximum intensity occurs at or near noon. Solar heat gain through all glass surface area normal to the incident light is a substantial fraction of the cooling load.
- **Horizontal and reflected radiation.** Intensity is significantly less, but the glass area is large enough to merit consideration.
- **Surface heating.** Surface temperature is a function of the solar energy absorbed, the interior and ambient temperatures, and the automobile's velocity.

Ambient Temperatures and Humidity. Several ambient temperatures need to be considered. Heaters are evaluated for performance at temperatures from –40 to 70°F. Air-conditioning systems are evaluated from 40 to 110°F, although ambient temperatures above 125°F are occasionally encountered. The load on the air-conditioning system is also a function of ambient humidity (at most test conditions this latent load is around 30% of the total). There is no consensus among manufacturers on the design point for an air-conditioning system. Typical design points follow the combinations of ambient temperature and humidities of higher probability, starting at around 90% rh at 90°F and with decreasing humidity as temperature increases.

Because the system is an integral part of the vehicle, the effects of vehicle-generated local heating must be considered. For interior components, the design high temperature is usually encountered during unoccupied times when the vehicle is soaked in the sun. Interior temperatures as high as 160°F are regularly recorded after soaks in the desert southwestern United States. Achieving a comfortable interior temperature after such a hot soak is usually one of the design conditions for most vehicle manufacturers.

Operational Environment of Components

Underhood components may be exposed to very severe environments. Typical maximum temperatures can reach 250°F. The drive to achieve more fuel-efficient automobiles has reduced available space under the vehicle hood to a minimum. This crowding has exposed many components to temperatures approaching that of exhaust system components. Heat from the vehicle also adds to the cooling loads that the air-conditioning system must handle. During idle conditions, the heat convected off the hood can raise the temperature of the air entering the air inlet plenum by as much as 10 to 25°F. A similar effect is found during idle conditions when air from the engine compartment is re-entrained into the air flowing through the condenser. Air temperatures as high as 160°F have been encountered on parts of a vehicle's condenser during operation with a tail wind in ambient temperatures as low as 100°F.

Airborne Contaminants and Ventilation

Normal airborne contaminants may include bacteria, pollutants, vapors from vehicle fluids, and corrosive agents. Exposure to these

The preparation of this chapter is assigned to TC 9.3, Transportation Air Conditioning.

must also be considered when selecting materials for seals and heat exchangers. Incorporating particulate and/or carbon filters to enhance interior air quality is becoming common. The air-handling systems in virtually all vehicles are capable of exceeding the ventilation recommendations for buildings and public transportation in ASHRAE *Standard* 62. However, the driver has complete control of the HVAC system in the vehicle; the operator can reduce cabin airflow to virtually zero when desired (e.g., before warm-up on cold days).

Power Consumption and Availability

Many aspects of vehicle performance have a significant impact on vehicular HVAC systems. Modern vehicles have a huge variety of electric-powered systems. The need to power these systems while maintaining vehicle efficiency (gas mileage) leads manufacturers to demand a high level of efficiency in electrical power usage. On some vehicles, electrical power use is monitored and reduced during times of minimal availability. The mass of the HVAC system is also closely controlled to maintain gas mileage and ride or handling characteristics. The power source for the compressor is the vehicle's engine. At engagement, the need to accelerate the rotational mass as well as pump the refrigerant can double the engine torque. This sudden surge must not be perceptible to the driver, and is controlled through careful calibration of the engine controls. Automotive compressors must provide the required cooling while compressor speed varies with the vehicle condition rather than the load requirements. Vehicle engine speeds can vary from 500 to 8000 rpm.

Physical Parameters, Access, and Durability

The durability of vehicle systems is extremely important. Hours of operation are short compared to commercial systems (160,000 miles at 40 mph = 4000 h), but the shock, vibration, corrosion, and other extreme conditions the vehicle receives or produces must not cause a malfunction or failure. Automotive systems have some unique physical parameters, such as engine motion, proximity to components causing adverse environments, and durability requirements, that are different from stationary systems. Relative to the rest of the vehicle, the engine moves both fore and aft because of inertia, and in rotation because of torque; this action is referred to as **engine rock**. Fore and aft movement may be as much as 0.5 in.; rotational movements at the compressor may be more than as 0.75 in. from acceleration and 0.5 in. from deceleration when the length to center of rotation is considered. Additionally, the need for components to survive bumper impacts of up to 5 mph leads to additional clearance and strength requirements. Vehicle components may also be exposed to many different types of chemicals, such as road salt, oil, hydraulic fluid (brakes and power steering), and engine coolant.

The automobile is also increasingly incorporating electrical and electronic components and functionality. This requires manufacturers to both limit the emissions of electrical signals from components as well as ensure that all components will work when subjected to these same types of emissions. Manufacturers' requirements for electromagnetic compatibility are increasingly stringent regarding the frequencies of radio and communication devices.

Wiring, refrigerant lines, hoses, vacuum lines, and so forth must be protected from exhaust manifold heat and sharp edges of sheet metal. Normal service items such as oil filler caps, power steering filler caps, and transmission dipsticks must be accessible. Air-conditioning components should not have to be removed to access other components.

Noise and Vibration

The temperature control system should not produce objectionable sounds. During maximum heating or cooling operation, a

slightly higher noise level is acceptable. Thereafter, it should be possible to maintain comfort at a lower blower speed with an acceptable noise level. Compressor-induced vibrations, gas pulsations, blower motor vibration, and noise must be kept to a minimum. Suction and discharge mufflers are often used to reduce noise. Belt-induced noises, engine torsional vibration, and compressor mounting all require particular attention. Manufacturers have different requirements and test methods. Although it is almost impossible to predict vehicle sound level from component testing, a decrease in the sound and vibration energy at the source of noise will always decrease the noise level in vehicle (assuming there is not a shift in frequency), so most automobile manufacturers require continuous improvement in overall component sound level.

AIR-HANDLING SUBSYSTEM

The in-cabin air-handling unit, commonly called an **air-conditioning module (ACM)**, provides air to the passenger cabin. It incorporates the following basic components: heater core, evaporator core, blower motor, air-distribution control, ram air control, body vents, and air temperature controls. In addition to the ACM, an air inlet plenum, distribution ducting, outlets, and body relief vents make up the complete air-handling subsystems. The evaporator core is a part of both the refrigeration and air-handling subsystem and forms the link between the two. The heater core is similarly the link with the heating subsystem.

The basic function of the air-handling system is as follows. The air intake valve allows air from either the exterior (taken directly from the air intake plenum) or the cabin to be recirculated to the fan. The fan then pumps the air through the evaporator and into the temperature valve, which forces the air to either flow through or bypass the heater core to obtain the desired temperature. The air then moves to the distribution area of the module, where it is directed to one or more of the heater, ventilation, or defrost outlets. The air in the cabin then either is recirculated or exits out of the vehicle through body vents.

There are many variations on the basic ACM system. The more common ones include regulating the air discharge temperature using coolant flow control and separating the ACM into two or more subcomponents to better fit the system in the vehicle.

Air Delivery Modes

There are three basic modes in most vehicles today: heater, defroster, and air conditioning (or vent for vehicles without air conditioning). Typical mixed modes include bilevel, blend, and ambient.

Heater Mode. Heater mode is designed to provide comfort heating to vehicle occupants. Typical maximum heater airflow is 125 to 200 cfm for a mid-sized automobile. Heater air is generally distributed into the lower forward compartment, under the front seat, and up into the rear compartment. Air distribution near the floor also makes the vehicle more comfortable by providing slightly cooler air at breath level. Because the supply air temperature is relatively high, direct impingement on the occupant is not desirable. Heater air exhausts through body leakage points.

Heater mode warms the air in the vehicle above the dew points of the surrounding air and of the vehicle's glass. To prevent condensation from occupant respiration or from rain or snow tracked in, most vehicles sold in North America draw only exterior air when in heater mode and do not allow recirculation. However, some vehicle designs do allow recirculation, avoiding the higher cost of including the electric or vacuum actuation system necessary to prevent it.

Most vehicles also provide a small bleed of air (typically 7 to 12% of the total air flow) in heater mode to the windshield to isolate it from the car's interior. Properly designed, this prevents loss of visibility under most conditions.

Defrost Mode. Defrost mode is provided to clear the windshield from frost and fog, both internally and externally. Typical maximum airflow for defrost systems is 150 to 200 cfm for a mid-sized

automobile. Defrost mode requirements are given in Federal Motor Vehicle Safety *Standard* (FMVSS) 103, which defines areas on the windshield for driver vision and a time frame in which they must be able to be cleared under extreme vehicle operating conditions. Most vehicles are also equipped with side window demisters that direct a small amount of heated air and/or air with lowered dew point to the front side windows. Rear windows are typically defrosted by heating wires embedded in the glass.

As in heater mode, to prevent windshield fogging, most vehicles built in North America prevent air from being recirculated in defrost mode. In addition, many vehicles automatically operate the air-conditioning system in defrost if the ambient temperature is above a threshold (usually around 40°F). This provides an extra assist and safety factor by lowering the dew point of the air exiting the ACM to below ambient temperature.

Air-Conditioning (or Panel) Mode. The air-conditioning mode is provided for occupant comfort cooling and to ventilate the vehicle. Typical airflow for panel mode is 200 to 300 cfm in a mid-sized car. Because of the lower temperature differentials in this mode, airflow is provided in such a way that direct impingement on the occupants can be achieved if desired. As discussed in the Design Factors section, the higher heat fluxes and higher initial temperature at vehicle start-up frequently require that the system be capable of **spot cooling**, providing the cooling airflow directly on the occupants, before lowering the overall cabin temperature. For these reasons, it is very important to be able to achieve directability of the supply outlet on the occupants. The air-conditioning system is designed to have sufficient capacity to bring the interior temperature down rapidly; panel outlets must also be positionable, to move the airflow off the occupants after a few minutes of operation.

Bilevel Mode. The most common mixed mode, bilevel mode is designed for moderate-temperature operation with high solar loading. The system provides air to both the lower outlets and the panel outlets. Typically, the air from the panel outlets is 5 to 25°F cooler than the air from the lower outlets. This is to provide cooling to areas of the interior that have direct solar loading and to provide warm air to those that do not.

Blend Mode. The next most common mixed mode is blend mode, designed to provide a step between heater and defroster for times when extra heat is needed to keep the windshield clear but full defrost is not desired. A typical situation where blend mode is used is in city traffic during snowfall. The extra airflow to the windshield helps maintain a clear field of vision and still maintains adequate flow to lower outlets to keep occupants warm.

Ambient Mode. This mode, introduced more recently, is also designed for mild ambients. It is intended to provide a relatively high total airflow through the cabin but without the high local air velocities of the other modes. Typically, vehicles with an ambient mode are also equipped with additional panel outlets not directed toward the occupants. The most common configuration provides air toward the ceiling from outlets in the middle of the dashboard.

Controls

The HVAC control head (i.e., the controls for the ACM and the refrigeration system) is located within easy reach of the driver and occupants. These controls must be easy to use and not distract the driver from the road. There are many variations of HVAC controls in automobiles, from the cable-controlled manual system to fully automatic systems that control the cockpit environment. The two main classifications are manual and automatic.

The **manual control** is typically the base system that provides control for mode, temperature valve position, air source, and air flow rate (blower speed). In addition to air-handling controls, the control head usually also has a button to engage the compressor. Additional functions, such as rear defrost and seat heating controls, are frequently added to the control head. Although manual control provides a temperature mix door control, this is not a temperature

control; it will only control the opening of the temperature valve and fix the amount of air that bypasses the heater core. Therefore, if there is significant variation in ambient temperature or vehicle coolant temperature, the manual system will need to be adjusted. Manual systems typically have four or five blower speeds.

Automatic control uses a control unit and vehicle sensors to establish a comfortable thermodynamic environment for vehicle occupants. Sensors measure air inlet temperature, vehicle cabin temperature, and ACM discharge air temperature. The automatic control will then vary the mix door position, airflow rate, ACM mode, and air-conditioning compressor engagement. Some more-advanced systems measure cabin humidity for comfort control. Automatic systems usually have from 8 to 20 blower speeds.

Air quality control is also becoming available in many vehicles. Most of these systems assume that a vehicle will quickly pass through areas where the contamination source is prevalent. A sensor measures a **surrogate gas** (a gas that is not necessarily toxic but accompanies toxic gases that are more difficult to measure). When the surrogate gas is detected, the vehicle's air inlet door is positioned for recirculation to separate the occupants from the contamination source.

Air-Handling Subsystem Components

Air Inlet Plenum. The air inlet plenum is usually an integral part of the vehicle structure. There are two primary design considerations and several secondary design considerations for the air inlet plenum:

Primary

- Air that flows into the plenum should not be influenced by uncontrolled emissions from the vehicle systems; in other words, the plenum should be a source of clean air.
- The plenum should be located such that the aerodynamic effects of air movement over the vehicle increase the pressure in the plenum, so that when the vehicle operates with external air selected, air will flow through the air-handling unit into the vehicle. This will allow fresh air to flow through the vehicle and help reduce the amount of external air that infiltrates into the vehicle from uncontrolled sources.

Secondary

- The pressure drop of the plenum should also be considered. Higher airflow pressure requires that more power be available to the ACM blower and fan to provide adequate airflow.
- The airflow at the entrance to the ACM's blower should be uniform. In many vehicle applications, a significant loss in efficiency is caused by unbalanced airflow into the fan.
- The air inlet plenum must also serve several other functions, such as water separation, protection from snow ingestion, and gross filtration (usually through a screen).
- The air inlet plenum must also be located such that when the vehicle is covered by snow, the plenum will still be able to furnish sufficient air to clear the windshield and provide fresh air to the occupants.

The air inlet plenum is usually located at the base of the windshield. If properly sealed from the underhood areas of the vehicle, this provides a relatively high-pressure and clean source of air.

Distribution Ducting. Air from the air-handling unit is distributed to various areas of the vehicle through ducting. Typically, the main trunk duct exits the ACM near the middle of the dashboard. Ducting carries the air from this central location to the extremes of the instrument panel, the floor, and even the rear seat (if so equipped). The design goal for the distribution ducting is to distribute the air throughout the vehicle with as little pressure drop as possible. This goal is frequently compromised by the tight packaging constraints in modern vehicles.

Outlets. There are typically defrost, heater, side window, and panel air outlets in a vehicle. The defrost air outlet is located on top of the instrument panel to distribute air for clearing the windshield of frost and fog as quickly and efficiently as possible. Heater outlets are located on the bottom of the instrument panel to spread warm air over the floor pan of the vehicle. Panel outlets are designed to provide cool air to the occupants. The importance of the panel outlets should not be underestimated. The ability to achieve direct air impingement on occupants with little diffusion is very important to comfort after a vehicle has been inoperative during extremely hot summer conditions. Likewise, it is important to be able to direct the cool air away from occupants after the interior begins to cool down. The ability to direct the jet air and reach the occupants under all conditions can result in satisfied consumers; the lack of this ability has resulted in dissatisfied consumers even in vehicles with exceptional airflow and capacity.

Body Relief Vents. Body relief vents are designed to ensure airflow through the vehicle from front to rear. Typically, they are effectively low-pressure check valves, designed to allow airflow out of the vehicle when cabin pressure is above the local exterior pressure and to prevent infiltration of air when the local exterior pressure is above that of the interior (i.e., when the vehicle is using recirculated air as the air source). Relief vents should be located where they will cause the airflow inside the body to cover all occupant locations inside the vehicle.

A small number of openings in the vehicle body are required for wires, cables, and various attachment features; therefore, the body relief vent does not typically need to be sized large enough to exhaust the total airflow through the vehicle.

Heater Core. The heat transfer surface in an automotive heater is generally either copper/brass cellular, aluminum tube and fin, or aluminum-brazed tube and center. Each of these designs is in production in straight-through, U-flow, or W-flow configurations. The basics of each of the designs are outlined as follows:

- The **copper/brass cellular** design is not used frequently in new vehicles. It uses brass tube assemblies (0.006 to 0.016 in. wall thickness) as the water course, and convoluted copper fins (0.003 to 0.008 in. thick) held together with a lead-tin solder. The tanks and connecting pipes are usually brass (0.026 to 0.034 in. wall thickness) and again are attached to the core by a lead-tin solder.
- The **aluminum tube-and-fin** design generally uses round copper or aluminum tubes, mechanically joined to aluminum fins. U tubes can take the place of a conventional return tank. The inlet/outlet tank and connecting pipes are generally plastic and attached to the core with a rubber gasket.
- The **aluminum brazed tube-and-center** design uses flat aluminum tubes and convoluted fins or centers as the heat transfer surface. Tanks are either plastic and clinched onto the core or aluminum and brazed to the core. Connecting pipes are constructed of various materials and attached to the tanks a number of ways, including brazing, clinching with an O ring, fastening with a gasket, and so forth.

Air-side design characteristics include pressure drop and heat transfer. The pressure drop of the heater core is a function of the fin/louver geometry, fin density, and tube density. Capacity is adjusted by varying the face area of the core to increase or decrease the heat transfer surface area, adding coolant-side turbulators, or varying air-side surface geometry for turbulence.

Evaporator. Current automotive evaporator materials and construction include (1) copper or aluminum tube and fin, (2) brazed aluminum plate and fin, and (3) brazed serpentine tube and fin. This section addresses the air-side design of the evaporator. Air-side design parameters include air pressure drop, capacity, and condensate control.

Typically, an ACM is designed to provide the airflow required to provide cooling for the vehicle. The combination of airflow,

maximum allowable current draw for the blower motor, size constraints on the ACM, and ductwork act together to establish a required evaporator air-side pressure-drop characteristic. The air-side pressure drop of the core is typically a function of fin spacing, louver design, core depth, and face area. This characteristic varies with accumulation of condensate on the core, so adequate leeway must be allowed to achieve target airflow in humid conditions.

Conditions affecting evaporator capacity are different from those in residential and commercial installations in that the average operating time, from a hot-soaked condition, is less than 20 min. Inlet air temperature at the start of operation can be as high as 160°F, but decreases as the vehicle duct system is ventilated. Capacity requirements under multiple conditions must be considered when sizing an automotive evaporator, including steady-state operation at high or low speeds, and a point in a cooldown after an initial vehicle hot soak. Some of these requirements may also be set in recirculating conditions where the temperature and humidity of inlet air decrease as the car interior temperature decreases.

The evaporator load will also have a slightly higher sensible heat portion than indicated by ambient temperature. The heat gain from the vehicle and the temperature rise across the blower motor must be considered when sizing the evaporator.

During longer periods of operation, the system is expected to cool the entire vehicle interior rather than just produce a flow of cool air. During sustained operation, vehicle occupants want less air noise and velocity, so the air quantity must be reduced; however, sufficient capacity must be preserved to maintain satisfactory interior temperatures.

Condensate management is very important within a motor vehicle. In the process of cooling and dehumidifying the air, the evaporator extracts moisture from the air. It is imperative that condensate be prevented from entering the vehicle interior as a liquid, as this will damage the vehicle. This moisture should be carried out of the vehicle and not allowed to collect inside the ACM. A distinct odor can be identified in many cars that have plugged condensate drain holes. This odor is given off by common organisms, present almost everywhere, that grow in warm, moist environments.

Condensate management includes the following design objectives:

- Ensuring that the moisture coming off the evaporator is in large enough droplets so that it is not carried by the airstream (a combination of low velocity at the exit of the core and adequate ability of the core to allow surface tension to gather the water)
- Allowing sufficient fin spacing for adequate condensate drainage
- Allowing a large enough sump so that all of the water coming off the core can be collected for a short period of time when vehicle-manoeuvring forces are pushing the water away from the drain
- Providing sufficient slope to the drain area so that water will flow to the drain rather than collect within the case
- Having a sufficient cross section in the drain so that water does not back up into the module, taking into account the fact that ACM interior pressure is usually 1 to 2 in. of water above the exterior pressure

Vehicle attitude (slope of the road and inclines), acceleration, and deceleration should also be considered because these factors have a significant effect on the drain system design. Drains can become plugged not only by contaminants but also by road splash.

Blower Motor and Fans. Airflow in an automobile must provide sufficient cooling air to passengers in both the front and rear seats. Designs for the blower motor and fan, which must fit in a relatively small space, are frequently a compromise between packaging, mass, airflow, and efficiency. Virtually all fans used in automotive ACMs are centrifugal, with fan diameters from 5.5 to 8 in. Typical motor current draws vary from 14 to 25 A depending on factors affecting optimization of the particular application. Both forward- and rearward-inclined fan blades have been used.

Automotive systems today are achieving a significantly improved level of comfort. Much of this is due to reductions in the noise, vibration, and harshness (NVH) characteristics of the interior. This continued effort has required continuous improvement in the NVH characteristics of blower motor and fan assemblies. During integration of the blower motor and fan into the module, careful attention must be paid to any type of vibrational excitation the fan may impart to the ACM and other underdash components.

Electronic Blower Speed Control. Historically, the blower motor speed control was simply a selector switch that selected either from direct battery voltage at the blower motor or from one of two or more resistors in series with the blower motor to reduce voltage. In general, the lowest airflow selectable is usually driven by the need to provide adequate air pressure to cool the blower motor. Modern blower motor speed controls incorporate essentially infinite speed control using devices such as pulse width modulating (PWM) controllers. The newer devices are usually found on upscale vehicles using automatic climate control systems. When incorporating such devices as PWMs into a vehicle system, careful attention needs to be paid to radio frequency interference because of the necessary proximity of all the electronics in a vehicle.

Valves. The typical ACM has valves for the air inlet source, temperature control (heater air bypass), and mode control. Some vehicles also have a ram air door, used to reduce ram effect at high speeds and provide consistent airflow. Door/valve designs are integral to the ACM design. Door types include flag style, rotary, guillotine, and film valves. The optimal door type is almost always a function of the space in which a module must fit.

Actuators. Actuators on ACMs are usually cable, electric, and/or vacuum. **Cable-based actuation** is usually the least expensive and most frequently found in entry-level vehicles. The valving system must be designed to retain a position with minimal restraining torque, have smooth operation with essentially constant torque level, and have minimal torque required to move the valve(s). There must be a suitable cable path from the HVAC controls to the module. Cable actuation does not allow electronic control of the air-conditioning system or an interlock to ensure outside air is selected in defrost mode.

The norm for American automobiles 20 years ago, **vacuum actuation** is now giving way to electronic actuators. Vacuum actuators are capable of providing only three position controls per actuator and require a cross-sectional area for the diaphragm proportional to the load on the door. The vacuum source is the vehicle's engine intake air manifold. Although this provides a powerful control at engine idle, a great deal of variation exists in the working pressure differential, and must be taken into account in system design.

Electric actuators are capable of controlling the ACM electronically and are available in variety of shapes. The possibility of linear positions allows for multiple modes, with one actuator on several doors, using a cam system. They also isolate the operator from torque variations, allowing the ACM to be optimized for other performance criteria.

Air Inlet. The air inlet interfaces the ACM with the vehicle body. If not accomplished upstream, it is necessary for the air inlet to separate out water that may have been ingested from rain, car-washes, etc. It also provides the selection of either outside air or air recirculated from the passenger compartment. On upscale performance vehicles, the ram air door is also located here. A primary design criterion for the air inlet is to provide proper flow patterns at the inlet of the blower motor. In many applications this is compromised to fit the ACM into the vehicle. The result is either turbulence or misdistribution of air into the fan, causing noise and lower efficiency.

Mode Control. Distribution of air is usually done at the ACM by one or more valves directing the air to the desired vehicle outlets. This system may provide several discrete modes or a continuous variation from one mode to the next. ACM valving must be designed

to work with the distribution ductwork and provide the desired air distribution to the occupants.

Air Distribution. Air distribution must be done in a way that minimizes pressure loss, thermal lag, and heat gain. Ductwork is usually designed around the other underdash components, and frequently must follow a difficult path. The air for all outlets starts at one basic plenum pressure, and variations in pressure drop versus flow rate from side to side in the vehicle must be kept to a minimum to provide even airflow to both driver and passengers. Because of the instrument cluster in front of the driver and such devices as airbags, the ductwork is almost never laterally symmetrical. Computational fluid dynamics is used to ensure proper air distribution design.

Air Filter. Air filters are increasingly common, typically located in either the air inlet plenum or the ACM. Filters may be particulate, charcoal, or both; they require regular service to prevent clogging and ensure proper system function. Removal of contaminants (e.g., pollen) may also be aided by condensate on evaporator surfaces.

HEATING SUBSYSTEM

The primary heat source is the vehicle's engine. Coolant from the engine cooling system circulates through the heater core. Modern efficiency and emissions improvements have led to many types of supplemental heating produced today, including fuel-fired heaters, refrigerant heat pumps, electrical heaters, and heat storage systems.

The heater core must be designed to work within the design of the engine cooling system. Engine coolant pressure at the heater core inlet ranges up to 40 psig in cars and 55 psig on trucks.

Modern antifreeze coolant solutions have specific heats from 0.65 to 1.0 Btu/lb·°F and boiling points from 250 to 272°F (depending on concentration) when a 15 psi radiator pressure cap is used.

Controls

Engine coolant temperature is controlled by a thermostatically operated valve that remains closed until coolant temperature reaches 160 to 205°F. Coolant flow is a function of pressure differential and system restriction, but typically ranges from 0.6 gpm at idle to 10 gpm at higher engine speed.

Components

The minimal components of the heating subsystem are the coolant flow circuit (water pump) and temperature control, both provided by the vehicle's engine; the heater core (part of the ACM); and coolant hoses.

REFRIGERATION SUBSYSTEM

Cooling is almost universally provided by a vapor cycle system. The thermodynamics of a vapor cycle system are described in [Chapter 1 of the ASHRAE Handbook—Fundamentals](#). The automotive system is unique in several ways.

Refrigeration capacity must be adequate to bring the vehicle interior to a comfortable temperature and humidity quickly and then maintain it during all operating conditions and environments. A design may be established by mathematical modeling or empirical evaluation of known and predicted factors. A design tradeoff in capacity is sought relative to criteria for vehicle weight, component size, and fuel economy. Automotive system components must meet internal and external corrosion, pressure cycle, burst, and vibration requirements.

Refrigerant-based system equipment is designed to meet the recommendations of SAE *Standard* J639, which includes several requirements for refrigerant systems. To be compliant, a system must have

- A high-pressure relief device

- Burst strength (of components subjected to high-side refrigerant pressure) at least 2.5 times the venting pressure of the relief device
- Electrical cutout of the clutch coil before pressure relief to prevent unnecessary refrigerant discharge
- Low-pressure-side components with burst strengths in excess of 300 psi

The relief device should be located as close as possible to the discharge gas side of the compressor, preferably in the compressor itself.

Controls

Refrigerant Flow Control. Cycling-clutch designs are the most common mechanisms for controlling refrigerant flow. Schematics for the two most common versions of this design are shown in [Figures 1 and 2](#). The clutch is cycled by either a thermostat that senses evaporator temperature or a pressure switch that senses evaporator pressure. This thermostat or pressure switch serves two functions: it prevents evaporator icing, and it maintains a minimum refrigerant density at the inlet of the compressor, preventing overheating. Discharge air temperature is then increased, if necessary, by passing some (or all) of the evaporator outlet air through the heater core.

The clutch-cycling switch disengages at about 25 psig and engages at about 45 psig. Thus, the evaporator defrosts on each off-cycle. The flooded evaporator has enough thermal inertia to prevent rapid clutch cycling. It is desirable to limit clutch cycling to a maximum of six cycles per minute because a large amount of heat

is generated by the clutch at engagement. The pressure switch can be used with a thermostatic expansion valve in a dry evaporator if the pressure switch is damped to prevent rapid cycling of the clutch.

Cycling the clutch sometimes causes noticeable surges as the engine is loaded and unloaded by the compressor. This is more evident in cars with smaller engines. This system cools faster and at lower cost than a continuously running system.

For vehicles where clutch cycling is unwanted because of engine surge, or for high-end vehicles where no perceptible temperature swing is allowable, variable displacement compressors are available, controlled either electronically or pneumatically.

In the **pneumatically controlled compressor**, a sensor (usually located in the compressor body) varies the compressor displacement so that a constant pressure is maintained at the compressor inlet. This provides a nearly uniform evaporator temperature under varied loading conditions. This type of system causes no perceptible engine surge with air-conditioning system operation.

The **electronically controlled variable-displacement compressor** opens up many possibilities for systems optimization. This type of compressor allows reduced reheat control, and evaporator temperature is maintained at such a level that comfort is achieved with less fuel consumption. A wide range of control schemes using electronically controlled variable-displacement compressors are being developed.

Other Controls. A cycling switch may be included to start an electric fan when insufficient ram air flows over the condenser. Also, output from a pressure switch or transducer may be used to put the ACM into recirculation mode, which reduces head pressure by reducing the load on the evaporator. Other possibilities include a charge loss/low-ambient switch, transducer evaporator pressure control, and thermistor control.

Components

Compressor. Piston compressors dominate the automotive market, although scroll and rotary vane types are also significant. For detailed information on compressor design, see [Chapter 34 of the ASHRAE Handbook—HVAC Systems and Equipment](#). The typical automotive compressor has the following characteristics:

- **Displacement.** Fixed-displacement compressors have displacements of 6.1 to 12.6 in³/rev. Variable-displacement piston compressors typically have a minimum displacement of about 6% of their maximum displacement. A typical variable-capacity scroll compressor has a maximum displacement of 7.3 in³/rev and a minimum displacement of 10% of the maximum.
- **Physical size.** Fuel economy, lower hood lines, and more engine accessories all decrease compressor installation space. These features, along with the fact that smaller engines have less accessory power available, promote the use of smaller compressors.
- **Speed range.** Most compressors are belt-driven directly from the engine; they must withstand speeds of over 8000 rpm and remain smooth and quiet down to 500 rpm. The drive ratio from the vehicle engine to the compressor typically varies from 1:1 to 2:1. In the absence of a variable drive ratio, the maximum compressor speed may need to be higher to achieve sufficient pumping capacity at idle.
- **Torque requirements.** Because torque pulsations cause or aggravate vibration problems, it is best to minimize them. Minimizing peak torque benefits the compressor drive and mount systems. Multicylinder reciprocating and rotary compressors aid in reducing vibration. An economical single-cylinder compressor reduces cost; however, any design must reduce peak torques and belt loads, which are normally at a maximum in a single-cylinder design.
- **Compressor drives.** A magnetic clutch, energized by power from the vehicle engine electrical system, drives the compressor. The clutch is always disengaged when air conditioning is not required.

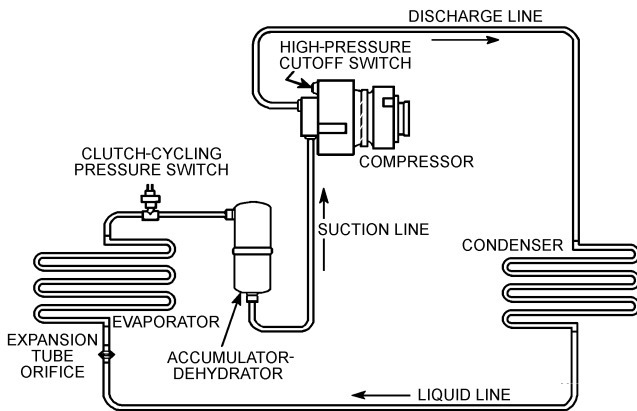

Fig. 1 Clutch-Cycling System with Orifice Tube Expansion Device

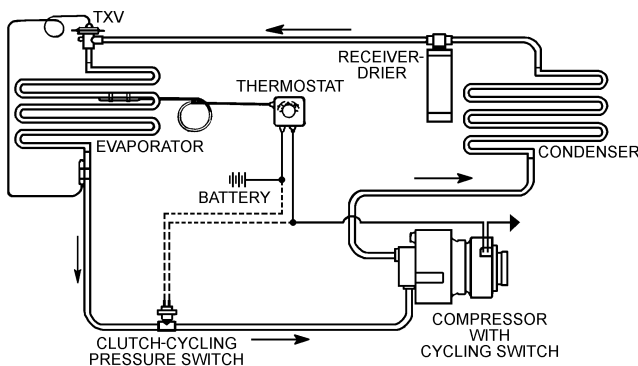

Fig. 2 Clutch-Cycling System with Thermostatic Expansion Valve (TXV)

The clutch can also be used to control evaporator temperature (see the section on Controls).

- **Variable-displacement compressors.** Both axial plate and wobble plate variable-displacement compressors are available for automobile air conditioning. The angle of the plate changes in response to the suction and discharge pressure to achieve a constant suction pressure just above freezing, regardless of load. A bellows valve or electronic sensor-controlled valve routes internal gas flow to control the angle of the plate.
- **Noise, vibration, and harshness.** With decreasing mass and increasing environmental quality in today's automobiles, compressor design is increasingly driven by NVH concerns. Vibrational input to the structure, suction and discharge line gas pulsations, and airborne noise must all be minimized. NVH minimization is now the main impetus behind most continuous improvement efforts in the automotive compressor industry.
- **Mounting.** Compressor mounts are an important part of a successful integration of a compressor into a vehicle system. Proper mounting of the compressor minimizes structural resonances and improves the NVH characteristics of any compressor.

Condenser. Automotive condensers are generally of the following designs: (1) tube-and-fin with mechanically bonded fins, (2) serpentine tube with brazed, multilouvered fins, or (3) header extruded tube brazed to multilouvered fins. To prevent air bypass, condensers generally cover the entire radiator surface. Aluminum is popular for its low cost and weight.

Condensers must be properly sized. An undersized condenser results in high discharge pressures that reduce compressor capacity, increase compressor power requirements, and result in poorer discharge air temperatures. When the condenser is in series with the radiator, the air restriction must be compatible with the engine cooling fan and engine cooling requirements. Generally, the most critical condition occurs at engine idle under high-load conditions. An undersized condenser can raise head pressures sufficiently to stall small-displacement engines.

An oversized condenser may produce condensing temperatures significantly below the engine compartment temperature. This can result in evaporation of refrigerant in the liquid line where the liquid line passes through the engine compartment (the condenser is ahead of the engine and the evaporator is behind it). Engine compartment air has been heated not only by the condenser but by the engine and radiator as well. Typically, this establishes a minimum condensing temperature between 10 and 30°F above ambient. Liquid flashing occurs more often at reduced load, when the liquid line velocity decreases, allowing the liquid to be heated above saturation temperature before reaching the expansion valve. This is more apparent on cycling systems than on systems that have a continuous liquid flow. Liquid flashing is audibly detected as gas enters the expansion valve. This problem can be reduced by adding a subcooler or additional fan power to the condenser.

Internal pressure drop should be minimized to reduce compressor power requirements. Condenser-to-radiator clearances as low as 0.25 in. have been used, but 0.5 in. is preferable. Primary-to-secondary surface area ratios vary from 8:1 to 16:1. Condensers are normally painted black so that they are not visible through the vehicle's grille.

Placing the condenser ahead of the engine-cooling radiator not only restricts air but also heats the air entering the radiator. Air conditioning increases requirements on the engine-cooling system, which requires an increase in either radiator capacity, engine-cooling airflow, or both. Radiator capacity can be increased by adding fins, depth, or face area or by raising pump speed to increase coolant flow. Increasing coolant velocity is not normally done because it may cause excessive tube erosion or cavitation at the coolant pump inlet. With this configuration, engine-cooling airflow requirements increase; they are met by increasing fan size,

number of blades, blade width, blade pitch, by the addition of a fan shroud, or a combination of these items. Increases in fan speed, diameter, and pitch raise the noise level and power consumption. For engine-driven fans (primarily used on trucks), temperature- and torque-sensitive drives (viscous drives or couplings) or flexible-blade fans reduce the increases in noise that come with the higher power. Virtually all automobiles rely on airflow produced by the forward motion of the car to reduce the amount of air the engine-cooling fan must move to maintain adequate coolant temperatures. As vehicle speed increases, fan requirements drop, and electric fans are de-energized or engine-driven fans are decoupled by the action of the viscous drive.

Because each vehicle is optimized for its intended market segment, some vehicles have a side-by-side condenser and radiator, each with its own motor-driven fan. This eliminates the effect of the condenser on the engine cooling air inlet temperature but causes other issues with fan control and potential engine bay recirculation when one system is energized and the other is not.

Hoses. Rubber hose assemblies are installed where flexible refrigerant transmission connections are needed because of relative motion between components (usually due to engine rock) or where stiffer connections cause installation difficulties and noise transmission. Refrigerant effusion through the hose wall is a design concern. Effusion occurs at a reasonably slow and predictable rate that increases as pressure and temperature increase. Hose with a nylon core is less flexible, has a smaller OD, is generally cleaner, and allows practically no effusion. However, because it is less flexible, it does not provide damping of gas pulsations as does other hose material. It is recommended for Refrigerant 134a.

Expansion Devices. Virtually all modern automobiles use either a thermostatic expansion valve (TXV) or an orifice tube (or both, for dual evaporator systems) as the expansion device (see [Chapter 45 of the ASHRAE Handbook—Refrigeration](#) for more on these devices). Schematics of systems that use these devices are provided in the Controls section.

Automotive TXVs operate in the same manner as those for commercial HVAC systems. Both liquid- and gas-charged power elements are common. Internally and externally equalized valves are used as dictated by system design. Externally equalized valves are necessary where high evaporator pressure drops exist. A bulbless expansion valve, usually block-style, that senses evaporator outlet pressure without the need for an external equalizer is now widely used. TXV systems use a receiver-drier-filter assembly for refrigerant and desiccant storage.

Because of their low cost and high reliability, orifice tubes have become increasingly popular with automotive manufacturers. Developing an orifice tube system requires that components be matched to obtain proper performance. The orifice tube is designed to operate at 90 to 95% quality at the evaporator outlet, which requires a suction line accumulator to protect the compressor from floodback and to maintain oil circulation. Because the orifice tube does not fully use the latent heat in the refrigerant systems, orifice-tube systems generally require higher refrigerant flow than TXV systems to achieve the same performance. However, an orifice tube ensures that the compressor receives a continuous flow of cool refrigerant from the accumulator, offering benefits in compressor durability over a TXV system. Orifice-tube systems use an accumulator-drier-filter for refrigerant and desiccant storage.

Receiver-Drier-Filter Assembly. The receiver-drier assembly accommodates charge fluctuations from changes in system load. It accommodates an overcharge of refrigerant to compensate for system leaks and hose effusion. The assembly houses the high-side filter and desiccant. Several types of desiccant are used, the most common of which is spherical molecular sieves; silica gel is occasionally used. Mechanical integrity (freedom from powdering) is important because of the vibration to which the assembly is exposed. For this reason, molded desiccants have not obtained

wide acceptance. Moisture retention at elevated temperatures is also important. The rate of release with temperature increase and the reaction while accumulating high concentration should be considered. Design temperatures of at least 140°F should be used.

The receiver-drier often houses a sight glass that allows visual inspection of the system charge level. Receivers are usually (though not always) mounted on or near the condenser. They should be located so that they are ventilated by ambient air. Pressure drop should be minimal.

Suction Line Accumulators. A suction line accumulator is required with an orifice tube to ensure uniform return of refrigerant and oil to the compressor, to prevent slugging, and to cool the compressor. It also stores excess refrigerant. A typical suction line accumulator is shown in Figure 3. A bleed hole at the bottom of the standpipe meters oil and liquid refrigerant back to the compressor. The filter and desiccant are contained in the accumulator because no receiver-drier is used with this system.

Evaporator. The evaporator connects the air side of the air conditioning system to the refrigerant side. Design aspects for the air side are discussed in the Air-Handling Subsystem section. The primary design consideration for the refrigerant side of the evaporator is low pressure drop. Because the evaporator operates at saturation, higher-pressure-drop evaporators will cause nonuniform discharge temperatures unless they are designed with careful attention to pass arrangement. The space available in an automotive system does not allow for distribution manifolds and capillary tube systems outside of the evaporator envelope; this must be done within the evaporator itself.

Automotive evaporators must also mask the variation in compressor capacity that occurs with accelerating and decelerating. To avoid undesirable temperature splits, sufficient liquid refrigerant should be retained at the last pass to ensure continued cooling during acceleration.

High refrigerant pressure loss in the evaporator requires externally equalized expansion valves. A bulbless expansion valve, called a block valve, provides external pressure equalization without the added expense of an external equalizer. The evaporator must provide stable refrigerant flow under all operating conditions and have sufficient capacity to ensure rapid cooldown of the vehicle after it has been standing in the sun.

Auxiliary Evaporators. Many sport-utility vehicles, vans, and limousines are equipped with auxiliary or secondary air-conditioning modules located to cool the rear seat passengers. These system

extensions provide some unique challenges. The majority of these systems operate only during the time when there are passengers in the rear space. Consequently, sometimes there is refrigerant flow through the primary ACM and none through the secondary. Careful attention should be paid to refrigerant plumbing to avoid refrigerant and oil traps in the suction line. The auxiliary suction line must never allow liquid oil to run downhill from the front system when there is no flow to carry it back to the accumulator-dehydrator. Designing highly efficient oil separators into the line set results in frequent compressor failure.

Refrigerants and Lubricants. The 1997 Kyoto Protocol identified the almost universally used R-134a as a global warming gas. This has led to a search for alternatives among vehicle manufacturers and their suppliers. The leading contenders today are carbon dioxide, hydrocarbon-based refrigerants (most concepts using a secondary coolant loop to keep the explosive refrigerant out of the passenger compartment), and ultralow-emission R-134a systems. Insufficient information exists to determine whether any one of these systems will be able to achieve the predominant position of R-134a today.

New Vehicles. The phaseout of R-12 has led to the use of non-chlorofluorocarbon (non-CFC) alternatives in vehicles. The popular choice is R-134a because its physical and thermodynamic properties closely match those of R-12. Because its miscibility with mineral oil is poor, R-134a requires the use of synthetic lubricants such as polyalkylene glycol (PAG) or polyol ester (POE). PAGs are currently preferred. These lubricants—especially PAGs—are more hygroscopic than mineral oil; production and service procedures must emphasize the need for system dehydration and limited exposure of the lubricants to atmospheric moisture.

Older Vehicles. Vehicles originally equipped with R-12 do not require retrofit to another refrigerant as long as an affordable supply of new or reclaimed R-12 exists. When circumstances require it, most air conditioners can be modified to use R-134a and POE. When PAG oil is used in a retrofit, the remaining mineral oil should be removed to levels established by the original equipment manufacturer to prevent residual chlorides from breaking down the PAG.

R-22 is not suitable for topping off or retrofit in R-12 systems; it will produce unacceptable discharge pressures (up to 640 psig at idle) and temperatures. R-12 idle discharge pressures, on the other hand, would reach only 435 psig. In addition, R-22 may be incompatible with elastomeric seals and hose materials.

Several blends of two or more refrigerants are being sold as “drop-in” replacements for R-12. They should not be used without a thorough investigation of their effect on performance and reliability under all operating conditions. Other concerns include (1) flammability, (2) fractionation, (3) evaporator temperature glide, (4) increased probability of adding the wrong refrigerant or oil in future service, and (5) compounded complexity of refrigerant reclaim.

MASS-TRANSIT AIR CONDITIONING

Mass-transit vehicles include buses, rail cars, and fixed-guideway vehicles that transport large numbers of people in vehicles considerably larger than automobiles. The air-conditioning systems for these vehicles generally use commercial components more than automobile systems do; however, the component packaging is as specific to the application as on automobiles and is often integral with styling. Weight, envelope, and power consumption are important factors. Power sources may be electrical (ac or dc), engine shaft, compressed air, or hydraulic. These sources may be limited, variable, and interruptible. Characteristics specific to each application are discussed in the following subsections. Design aspects common to all mass-transit HVAC systems include passenger comfort (ventilation, thermal comfort, air quality, expectation) and thermal load

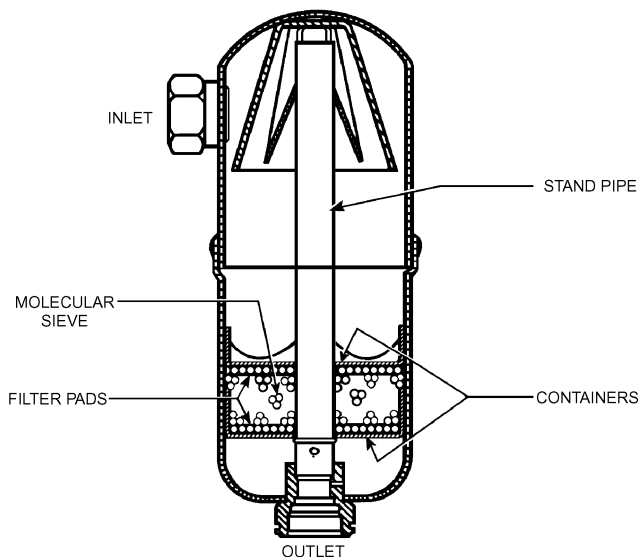

Fig. 3 Schematic of Typical Accumulator-Dehydrator

analysis (passenger dynamic metabolic rate, solar loading, infiltration, multiple climates, vehicle velocity, and, in urban applications, rapid interior load change).

VENTILATION AND THERMAL COMFORT

The requirements of ASHRAE *Standards 55* and *62* apply, with special considerations, for transportation applications. These considerations involve length of occupancy, occupancy turnover, infiltration, outside air quality, frequency and duration of door openings, personal preference, interior contamination sources such as smoking, and exterior contamination sources such as engine exhaust.

Typically, outside air ventilation between 3 and 10 cfm per passenger (at nominal passenger load conditions) is mechanically supplied at all times, although some variable-volume systems have been applied. Full load is defined by the specification documents. It may be based on the number of seats (for long distances) or also include a number of standees (for short distances), usually about 50% of the maximum standees possible. Measurement of CO₂ for air quality control is not practical in these applications because of extremely variable background CO₂ levels. The effective ventilation rate per passenger is generally somewhat higher than the nominal mechanical supply, and varies with the type of vehicle, length of ride, door openings, and average passenger occupancy. An important consideration is emergency ventilation when other systems fail; for example, the propulsion system may strand passengers in a situation where exit is not possible.

Clothing and the environment from which passengers come, including how long they were exposed to those conditions and what they were doing, are important factors in transit comfort. For example, a person running for a ride and/or waiting in a hot or cold climate before boarding for a 10 min ride in clothing fit for outside is not a typical building occupant. Jones et al. (1994) evaluated the heat load imposed by people under transient weather and activity conditions as opposed to steady-state metabolic rates traditionally used. An application program, TRANMOD, was developed that allows a designer to predict the thermal loads imposed by passengers (Jones and He 1993). Variables are activity, clothing, wet-bulb and dry-bulb temperatures, and precipitation. A passenger will adjust to a new environment in about 10 to 20 min; after that, the traditional comfort indices begin to apply. Before stabilization, a passenger may prefer higher-velocity air or cooler or warmer temperatures, depending to a certain extent on clothing. At the same time, other passengers may already have stabilized and have completely different comfort control desires. Therefore, the transit system designer is presented with a number of unusual requirements in providing comfort for all.

European *Standards* Draft EM 13129-1 and Draft pr EM13129-3 provide guidance in the area of passenger comfort for railroad main line and urban rolling stock, respectively. The status of these draft standards should be verified before using them. When adopted, they will not apply to countries outside of the European Committee for Standardization. Nonetheless, the information in these standards is valuable and may not be readily available elsewhere.

THERMAL LOAD ANALYSIS

Cooling Design Considerations

Thermal load analysis for transit applications differs from stationary, building-based systems because vehicle orientation and occupant density are changing regularly on street-level and subway vehicles and to a somewhat lesser degree on commuter and long-distance transportation. Summer operation is particularly affected because cooling load is affected more by solar and passenger heat gain than by outside air conditions. ASHRAE design parameters for occupant comfort may not always apply because occupancy time is usually much shorter than that spent in a build-

ing. Vehicle construction does not allow the low conductivity levels of buildings, and fenestration material must have safety features not necessary in other applications. For these reasons, thermal loads must be calculated differently. Because main-line passenger rail cars and buses must operate in various parts of the country, the air conditioning must be designed to handle the national seasonal extreme design days. Commuter and local transit vehicles operate in a small geographical area, so only the local design ambient conditions need be considered.

The following cooling load components should be considered:

- Ambient air conditions for locations in North America and around the world are given in [Tables 1B, 2B, and 3B in Chapter 27 of the ASHRAE Handbook—Fundamentals](#). For subway car operation, tunnel temperatures should be considered.
- For vehicle interior comfort conditions, consult [Figure 5 in Chapter 8 of the ASHRAE Handbook—Fundamentals](#). Total heat gain from passengers depends on the passenger activity before boarding the vehicle, the time waiting before boarding, journey time, and whether they are standing or seated during the journey. Representative values are given in [Table 1 in Chapter 29 of the ASHRAE Handbook—Fundamentals](#).
- Ventilation air requirements should be calculated using the method in [Chapter 29 of the ASHRAE Handbook—Fundamentals](#), in the section on Infiltration and Ventilation Heat Gain. The airflow rate should be 3 to 10 cfm per passenger, and air leakage and air entering during door dwell time should be taken into account.
- Interior heat includes that produced by the evaporator fan motor, inside lighting, and electrical controls.
- The vehicle's conductivity, in Btu/h·°F, should be provided by the vehicle designers. For the outside skin temperature, use the values in [Table 15 in Chapter 29 of the 1997 ASHRAE Handbook—Fundamentals](#); the car design dry bulb should be used as the interior temperature.
- The instantaneous solar gain through the glazing should be calculated using summer midafternoon values and the glass shading coefficient. The direction of travel for this period of the day should be determined before using the solar heat gain factors listed in [Chapter 29 of the ASHRAE Handbook—Fundamentals](#). The glass shading coefficient must be obtained from the window supplier.

The summer cooling analysis should be completed for different times of the day and different passenger densities to verify a reliable result. Cooling equipment capacity should exceed the cooling load to allow for eventual deterioration of heat transfer surfaces.

Heating Design Considerations

Winter outside design conditions can be taken from [Tables 1A, 2A, and 3A in Chapter 27 of the ASHRAE Handbook—Fundamentals](#). Interior temperatures can be taken from [Figure 5 in Chapter 8 of the ASHRAE Handbook—Fundamentals](#). During winter, conductivity is the major heat loss. The heat required to temper ventilation air and to counteract infiltration through the body and during door openings must also be considered.

Other Considerations

Harsh environments and the incursion of dirt and dust inhibit the efficiency of HVAC units. Specifications should include precise maintenance instructions to avoid capacity loss and compromised passenger comfort.

BUS AIR CONDITIONING

Introduction

In general, bus air-conditioning systems can be classified as interurban, urban, or small/shuttle bus systems. Bus air-conditioning

design differs from other air-conditioning applications because of climatic conditions in which the bus will operate, equipment size limitations, and compressor rpm. Providing a comfortable climate inside a bus passenger compartment is difficult because the occupancy rate per unit of surface and volume is high, glazed area is very large, and outside conditions are highly variable. Factors such as high ambient temperatures, dust, rain, snow, road shocks, hail, and sleet should be considered in the design. Units should operate satisfactorily in ambient conditions from -22 to 122°F.

Ambient air quality must also be considered. Air intakes are usually subjected to thermal contamination from road surfaces, condenser air recirculation, or radiator air discharge. Vehicle motion also introduces pressure variables that affect condenser fan performance. In addition, engine speed governs compressor speed, which affects compressor capacity. R-134a is the current refrigerant of choice, but some units operate with refrigerants such as R-22 or R-407C.

Bus air conditioners are initially performance-tested as units in a climate-controlled test cell. Performance tests encompass unit operation at different compressor speeds to make sure the compressor performance parameters (e.g., unit operation at maximum ambient conditions, minimum ambient condition, TXV sizing, oil return and vibration/shock) are within boundaries. In addition, individual parts that make the unit should be qualified before use. Larger test cells that can hold a bus are commonly used to verify installed unit performance. Pulldown tests previously known as the “Houston pulldown test” and the “White Book pulldown test” have been replaced by a test described in American Public Transportation Association (APTA) Standard Bus Procurement Guidelines.

Reliability and ease of maintenance are also important design considerations. All parts requiring service or regular maintenance should be readily accessible, and repairs should be achievable within a minimum time.

Heat Load

The main parameters that must be considered in bus air-conditioning system design include

- Occupancy data (number of passengers, distance traveled, distance traveled between stops, typical permanence time)
- Dimensions and optical properties of glass
- Outside weather conditions (temperature, relative humidity, solar radiation)
- Dimensions and thermal properties of materials in bus body
- Indoor design conditions (temperature, humidity, and air velocity)

The heating or cooling load in a passenger bus may be estimated by summing the heat flux from the following loads:

- Solid walls (side panels, roof, floor)
- Glass (side, front and rear windows)
- Passengers
- Engine and ventilation (difference in enthalpy between outside and inside air)
- Evaporator fan motor

Extreme loads for both summer and winter should be calculated. The cooling load is the most difficult load to handle; the heating load is normally handled by heat recovered from the engine. An exception is that an idling engine provides marginal heat in very cold climates. Jones and He (1993) and Andre et al. (1994) describe computational models for calculating the heat load in vehicles, as well as for simulating the thermal behavior of the passenger compartment.

The following conditions can be assumed for calculating the summer heat load in an interurban vehicle similar to that shown in [Figure 4](#):

- Capacity of 50 passengers
- Insulation thickness of 1 to 1.5 in.

- Double-pane tinted windows
- Outdoor air intake of 400 cfm
- Road speed of 65 mph
- Inside design temperatures of 60 to 80°F and 50% rh
- Ambient temperatures for location as listed in [Chapter 27 of the ASHRAE Handbook—Fundamentals](#)

Loads from 3.5 to 10 tons are calculated, depending on the outside weather conditions and on the geographic location of the bus. The typical distribution of the different heat loads during a summer day at 40° north latitude is shown in [Figure 5](#).

Air Distribution

Air-conditioning units are configured to deliver air through ducts to outlets above the windows or to act as free-blow units. In the case of free-blow units, louvers guide the air distribution inside the bus.

Interurban Buses

These buses are designed to accommodate up to 56 passengers. The air-conditioning system is usually designed to handle extreme conditions. Interurban buses produced in North America are likely

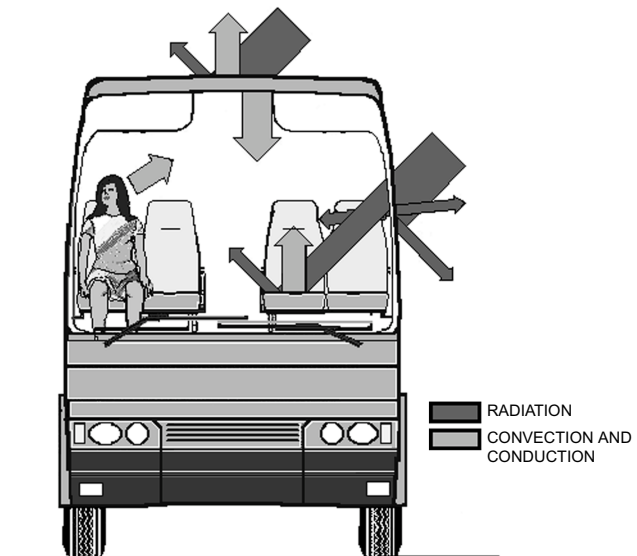

Fig. 4 Distribution of Heat Load (Summer)

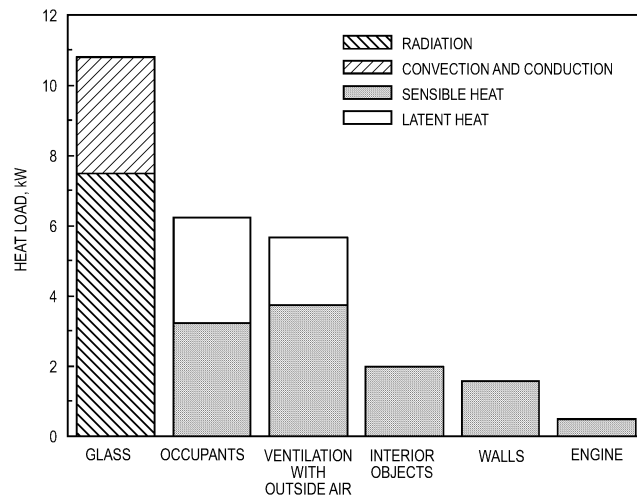

Fig. 5 Main Heat Fluxes in a Bus

to have the evaporator and heater located under the passenger compartment floor. A four- or six-cylinder reciprocating compressor, in which some cylinders are equipped with unloaders, is popular. Some interurban buses have a separate engine-driven compressor, preferably scroll, to give more constant system performance. Figure 6 shows a typical air-conditioning arrangement for an interurban bus.

Urban Buses

Urban bus heating and cooling loads are greater than those of the interurban bus. A city bus may seat up to 50 passengers and carry a “crush load” of standing passengers. The fresh air load is greater because of the number of door openings and the infiltration around doors. Cooling capacity required for a typical 50-seat urban bus is from 6 to 10 tons. The buses are usually equipped with a roof- or rear-mounted unit as shown in Figure 7. A four- or six-cylinder compressor, usually belt- or shaft-driven and equipped with unloaders, is popular.

The heater is located just downstream of the evaporator. Hot coolant from the engine-cooling system provides sufficient heat for most operations; however, additional sources may be required in colder climates for longer idling durations. Additional floor heaters may also be required to reduce the effects of stratification. Conditioned air is delivered through overhead combination light fixture/diffuser ducts.

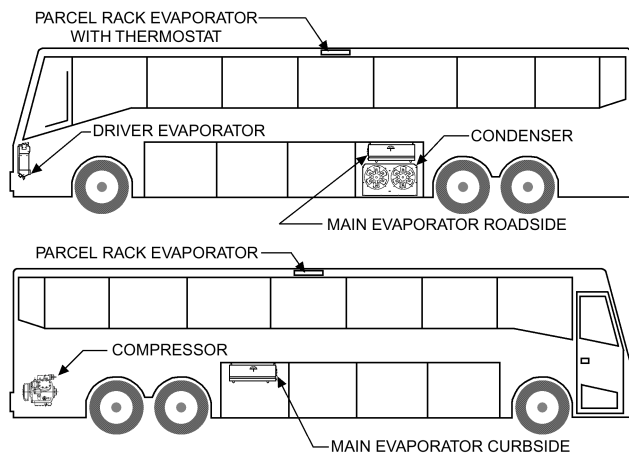

Fig. 6 Typical Arrangement of Air-Conditioning in an Interurban Bus

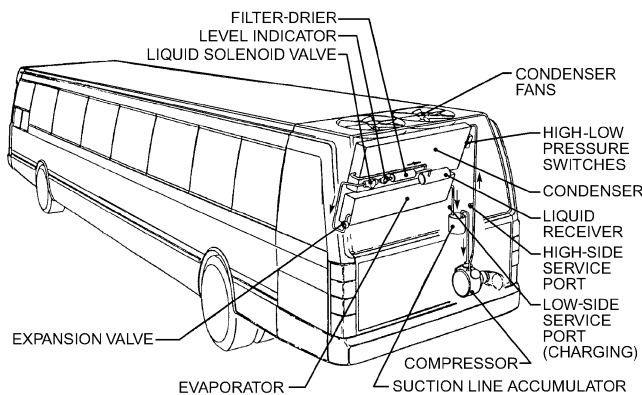

Fig. 7 Typical Mounting Location of Urban Bus Air-Conditioning Equipment

Low-profile rooftop-mounted units are used for either urban or interurban buses. They consist of the entire air-conditioning system except for the compressor, which is shaft- or belt-driven from the bus engine.

Small or Shuttle Buses

For small or shuttle buses such as those typically operating around airports or for schools, the evaporator is usually mounted in the rear and the condenser on the side or the roof of the bus. The evaporator unit is typically a free-blow unit.

Refrigerant Piping

Refer to Chapters 2 and 46 of the *ASHRAE Handbook—Refrigeration* for standard refrigerant piping practices. All components in the bus air-conditioning system are interconnected by copper tubing or refrigerant hose. When using copper tubing, care should be taken to analyze the impact of vibration on the tubing. Vibrational impact can be minimized by using vibration absorbers or other shock-cushioning devices. When using refrigerant hose, properties such as moisture ingress, effusion, maximum operating temperature, and burst pressure need to be taken into account. The refrigerant hose chosen should have the minimum amount of wax extractables on interaction with oil and the refrigerant.

Shock and Vibration

Most transport air-conditioning manufacturers design components for shock loading and vibrational inputs. Vibration eliminators, flexible lines, and other shock-cushioning devices interconnect the various air-conditioning components. The vibration characteristics of each component are different; in addition, the evaporator and the condenser must undergo individual vibration and shake tests. The input levels for the shake test can be based on the worst road conditions that the bus will encounter. This input level will vary because of the weight of the unit and its mounting.

System Safety

Per the U.S. Department of Transportation, all buses with air-conditioning systems operating in North America should conform to Federal Motor Vehicle Safety Standard (FMVSS) No. 302 for flammability standards. In addition, all evaporator units inside the vehicle should be mounted away from the head impact zone as specified by FMVSS 222, School Bus Seating and Crash Protection.

Controls

Most buses have a simple driver control to select air conditioning or heating. In both modes, a thermal sensing element (thermistors, mercury tube, etc.) controls these systems with on/off circuitry and actuators. Many current systems use solid-state control modules to interpret the bus interior and outside ambient temperatures and to generate signals to operate full or partial cooling or heating functions. In these systems, thermistor temperature sensors are used, which are usually more stable and reliable than electromechanical controls. Control systems for urban buses can also include an outside-air ventilation cycle. The percentage of fresh air intake during the ventilation cycle can vary based on individual requirements.

RAIL CAR AIR CONDITIONING

Passenger rail car air-conditioning systems are generally electro-mechanical, direct-expansion units, usually using R-22, a hydrochlorofluorocarbon (HCFC). As HCFC refrigerants are phased out, the most likely replacements are hydrofluorocarbons (HFCs) R-407C or R-410A. Because R-410A operates at a higher pressure, it is not a viable replacement refrigerant for existing R-22 systems. R-407C does have closely similar operating characteristics to R-22 and can, in many cases, be used as a replacement with minimal

system changes. R-134a, a medium-pressure refrigerant, is used in Europe in conjunction with variable-speed screw compressors that are competitive in weight to R-22 reciprocating compressors. There is no clear refrigerant choice for future equipment.

Electronic, automatic controls are common, with a trend toward microprocessor control with fault monitoring, logging, and feedback to a central car-information system. Electric heating elements in the air-conditioning unit or supply duct temper outdoor air brought in for ventilation and also control humidity by reheating the conditioned supply air during cooling partial-load conditions. Decreased space availability and stringent weight requirements in modern equipment have favored lighter and more space-efficient equipment.

Vehicle Types

Main-line intercity passenger rail service generally operates single and bilevel cars hauled by a locomotive. Locomotive-driven alternators or static inverters distribute power via an intercar cable power bus to air-conditioning equipment in each car. A typical rail car has a control package and two air-conditioning systems. The units are usually either split, with the compressor/condenser units located in the car undercarriage area and the evaporator-blower portion mounted in the ceiling area, or self-contained packages mounted in interior equipment rooms. Underfloor and roof-mounted package units are less common in intercity cars.

Commuter cars used to provide passenger service from the suburbs into and around large cities are similar in size to main-line cars. Air-conditioning equipment in these cars generally consists of two evaporator-heater fan units mounted above the ceiling with a common or two separate underfloor-mounted compressor-condenser unit(s) and a control package. These cars may be locomotive hauled and have air-conditioning arrangements similar to main-line intercity cars, but they are often self propelled by high-voltage direct current (dc) or alternating current (ac) power supplied from an overhead catenary or from a dc-supplied third rail system. On such cars, the air conditioning may operate on ac or dc power. Self-propelled diesel-driven vehicles that use on-board-generated power for the air-conditioning systems still operate in a few areas.

Subway and elevated rapid-transit cars usually operate on a third rail dc power supply. The air-conditioning system motors sometimes are powered directly from the third rail dc supply voltage or on three-phase ac supply from an alternator or inverter mounted under the car. Split air-conditioning systems are common, with evaporators in the interior ceiling area and underfloor-mounted condensing sections.

Streetcars and light-rail vehicles usually run on the city ac or dc power supply and have air-conditioning equipment similar to rapid-transit cars. Roof-mounted packages are used more often than undercar or split systems. This is partly because of the lack of undercar space availability and, in cases where a sufficient clearance envelope will allow, the roof-mounted location offers the most convenient location for add-on systems and for modifying rail vehicles designed without HVAC.

Equipment Selection

The source and type of power dictate the type of air conditioning installed on a passenger rail car; weight, the type of vehicle, and the service parameters of the vehicle to which the system is applied are other major concerns. Thus, ac-powered, semihermetic reciprocating, vane, or scroll hermetic compressors, which are lighter than open machines with dc motor drives, are a common choice. However, each car design must be examined in this respect because dc/ac inverters may increase not only the total weight, but also the total power draw, because of conversion losses.

Other concerns in equipment selection include the space required, location, accessibility, reliability, and maintainability. Inte-

rior and exterior equipment noise levels must be considered both during the early stages of design and later, when the equipment is coordinated with the car builder's ductwork and grilles.

Design Considerations

Configuration and Space Constraints. Space underneath and inside a rail car is at a premium, especially on self-propelled light-rail vehicles and rapid-transit and commuter cars; this generally rules out unitary interior or underfloor-mounted systems. Components are usually built to fit the configuration of the available space. Overall car height, roof profile, ceiling cavity, and undercar clearance restrictions determine the shape and size of equipment.

Special Environmental Considerations. Dirt and corrosion constitute an important design factor, especially if the equipment is beneath the car floor, where it is subject to extremes of weather and severe dirt conditions. For this reason, corrosion-resistant materials and coatings must be selected. Aluminum has not proved durable in exterior exposed applications; the sandblasting effect tends to degrade any surface treatment on it. Because dirt pickup cannot be avoided, the equipment must be designed for quick and easy cleaning; access doors should be provided, and evaporator and condenser fin spacing is usually limited to 8 to 10 fins per inch. Closer spacing causes more rapid dirt build-up and higher cleaning costs. Dirt and severe environmental conditions must also be considered in selecting motors and controls.

Maintenance Provisions. Railroad HVAC equipment requires more maintenance and servicing than stationary units. A passenger rail car with sealed windows and a well-insulated structure becomes almost unusable if the air conditioning fails. The equipment therefore has many additional components to permit quick diagnosis and correction of a failure. Motors, compressors, control compartments, diagnostic test ports, and other maintenance points must be easily accessible for inspection or repair. However, changes in maintenance strategies and environmental regulations have caused some users to move away from fully on-car-serviceable air conditioners, and toward modular, self-contained units with hermetically sealed refrigerant systems. These units are designed for rapid removal and replacement and off-car repair in a dedicated air-conditioning service area. Microprocessor-based controls are designed to identify, log, and indicate system faults in a manner that facilitates expeditious diagnosis and repair.

Safety. Security of the air-conditioning equipment attachment to the vehicle must be considered, especially on equipment located beneath the car. Vibration isolators and supports should be designed to safely retain the equipment on the vehicle, even if the vibration isolators or fasteners fail completely. A piece of equipment that dangles or drops off could cause a train derailment. All belt drives and other revolving items must be safety guarded. High-voltage controls and equipment must be labeled by approved warning signs. Pressure vessels and coils must meet ASME test specifications for protection of passengers and maintenance personnel. Materials selection criteria include low flammability, low toxicity, and low smoke emission.

Special Design Considerations. The design, location, and installation of air-cooled condenser sections must allow for considerable discharge air recirculation and/or temporary extreme inlet air temperatures from adjacent equipment that may occur at passenger loading platforms or in tunnels. To prevent a total system shutdown because of high discharge pressure, a capacity reduction control device is typically used to reduce the cooling capacity, thus temporarily reducing discharge pressure. Evaporator sectional staging, variable compressor and evaporator fan speed control, and/or compressor cylinder unloading, coupled with electric reheat, are used to provide part-load humidity control.

Other Requirements

Most cars are equipped with both overhead and floor heat. The overhead heat raises the temperature of the recirculated and ventilation air mixture to slightly above the car design temperature. A duct limit thermostat is often used to prevent supply air from overheating, which can cause passenger discomfort because of temperature stratification. Floor heat offsets heat loss through the car body. Times of maximum occupancy, outdoor ambient, and solar gain must be ascertained. The peak cooling load on urban transit cars usually coincides with the evening rush hour, and the peak load on intercity rail cars occurs in the midafternoon.

Heating capacity for the car depends on body construction, car size, and the design area-averaged relative wind-vehicle velocity. In some instances, minimum car warm-up time may be the governing factor. In long-distance trains, the toilets, galley, and lounges often have exhaust fans. Ventilation airflow must exceed forced exhaust air rates sufficiently to maintain positive car pressure. Ventilation air pressurizes the car and reduces infiltration.

Air Distribution and Ventilation

The most common air distribution system is a centerline supply duct running the length of the car in the space between the ceiling and the roof. Air outlets are usually ceiling-mounted linear slot air diffusers. Louvered or egg crate recirculation grilles are positioned in the ceiling beneath the evaporator units. The main supply duct must be insulated from the ceiling cavity to prevent thermal gain/loss and condensation. Taking ventilation air from both sides of the roof line helps overcome the effect of wind. Adequate snow and rain louvers and, in some cases, internal baffles, must be installed on the outdoor air intakes. Separate outdoor air filters are usually paired with a return air filter. Disposable media or permanent, cleanable air filters are used and are usually serviced every month. Some long-haul cars, such as sleeper cars, require a network of delivered-air and return ducts. Duct design should consider noise and static pressure losses.

Piping Design

Standard refrigerant piping practice is followed. Pipe joints should be accessible for inspection and, on split systems, not concealed in car walls. Evacuation, leak testing, and dehydration must be completed successfully after installation and before charging. Piping should be supported adequately and installed without traps that could retard the flow of lubricant back to the compressor. Pipe sizing and arrangement should be in accordance with [Chapter 2 of the ASHRAE Handbook—Refrigeration](#). Evacuation, dehydration, and charging should be performed as described in [Chapter 46 of the ASHRAE Handbook—Refrigeration](#). Piping on packaged units should also conform to these recommendations.

Control Requirements

Car HVAC systems are automatically controlled for year-round comfort. In split systems, cooling-load variations are usually handled by two-stage direct-expansion coils and compressors equipped with suction pressure unloaders, electric unloaders, or speed control. Unitary systems may have hot-gas bypass to keep the compressor from cycling and reduce the cooling effect. Under low-load conditions, cooling is provided by outdoor air supplied by ventilation. During part-load cooling, electric reheat maintains humidity. Under low loads not requiring humidity control, the system assumes the ventilation mode. A pumpdown cycle and low-ambient lockout are recommended on split systems to protect the compressor from damage caused by liquid slugging. In addition, the compressor may be fitted with a crankcase heater that is energized during the compressor off cycle. During the heating mode, floor and overhead heaters are staged to maintain the car interior temperature. Today's controls use thermistors and solid-state electronics instead of elec-

tromechanical devices. The control circuits are normally powered by low-voltage dc or, occasionally, by single-phase ac.

Future Trends

Air cycle technology is being introduced in passenger rail car air conditioning in Germany (Giles et al. 1997); however, issues of greater weight, higher cost, and low efficiency need to be addressed before air cycle equipment will be widely accepted. Other trends include hermetic scroll compressors, screw compressors, variable-speed compressor drives, and significantly increased self-diagnostic capabilities included in microprocessor-based controls, and continued efforts to identify the best refrigerant for the long term.

FIXED-GUIDEWAY VEHICLE AIR CONDITIONING

Fixed-guideway systems, commonly called people movers, can be monorails or rubber-tired cars running on an elevated or grade level guideway, as seen at airports and in urban areas such as Miami. The guideway directs and steers the vehicle and provides electrical power to operate the car's traction motors, lighting, electronics, air conditioner, and heater. People movers are usually unmanned and computer-controlled from a central point. Operations control determines vehicle speed and headway and the length of time doors stay open, based on telemetry from individual cars or trains. Therefore, reliable and effective environmental control is essential.

People movers are usually smaller than most other mass-transit vehicles, generally having spaces for 8 to 40 seated passengers and generous floor space for standing passengers. Under some conditions of passenger loading, a 40 ft car can accommodate 100 passengers. The wide range of passenger loading and solar exposure make it essential that the car's air conditioner be especially responsive to the amount of cooling required at a given moment.

System Types

The HVAC for a people mover is usually one of three types:

- Conventional undercar condensing unit and compressor unit (which includes control box) connected with refrigerant piping to an evaporator/blower unit mounted above the car ceiling
- Packaged, roof-mounted unit having all components in one enclosure and mated to an air distribution system built into the car ceiling
- Packaged, undercar-mounted unit mated to supply and return air ducts built into the car body

Some vehicles are equipped with two systems, one at each end; each system provides one-half of the maximum cooling requirement. The systems, whether unitary or split, operate on the guideway's power supply, which, in the United States, is usually 60 Hz, 460 to 600 V (ac).

Refrigeration Components

Because commercial electrical power is available, standard semihermetic motor-compressors and commercially available fan motors and other components can be used. Compressors generally have one or two stages of unloaders, and/or hot-gas bypass is used to maintain cooling at low loads. Condenser and evaporator coils are copper tube with copper or aluminum fins. Generally, flat fins are preferred for undercar condensers to make it simpler to clean the coils. Evaporator/blower sections must often be designed for the specific vehicle and fitted to its ceiling contours. Condensing units must also be arranged to fit in the limited space available and still ensure good airflow across the condenser coil. R-22 is used in almost all of these systems, although some future systems will use R-407C to meet environmental standards (zero ozone depletion potential).

Heating

Where heating must be provided, electric resistance heaters that operate on the guideway power supply are installed at the evaporator unit discharge. One or two stages of heat control are used, depending on the size of the heaters.

Controls

A solid-state control is usually used to maintain interior conditions. The cooling set point is typically between 74 and 76°F. For heating, the set point is 68°F or lower. Some controls provide humidity control by using electric heat. Between the cooling and heating set points, blowers continue to operate on a ventilation cycle. On rare occasions, two-speed blower motors are used, switching to low speed for the heating cycle. Some controls have internal diagnostic capability; they are able to signal the operations center when a cooling or heating malfunction occurs.

Ventilation

With overhead air-handling equipment, outside air is introduced into the return airstream at the evaporator entrance. Outside air is usually taken from a grilled or louvered opening in the end or side of the car. Depending on the configuration of components, the fresh air is filtered separately or directed so that the return air filter can handle both airstreams. For undercar systems, a similar procedure is used, except the air is introduced into the system through an intake in the undercar enclosure. In some cases, a separate fan is used to induce outside air into the system.

The amount of mechanical outdoor air ventilation is usually expressed as cfm per passenger on a full-load continuous basis. Passenger loading is not continuous at full load in this application, with the net result that more outside air is provided than indicated. The passengers may load and unload in groups, which causes additional air exchange with the outside. Frequent opening of doors, sometimes on both sides at once, allows additional natural ventilation. The effective outside air ventilation per passenger is a summation of all these factors. Some older vehicles currently in service have no mechanical outside air supply. Newer vehicles have up to 10 cfm per passenger. Lower values of mechanical ventilation, typically 5 cfm or less per passenger, are associated with travel times of less than 2 min and large passenger turnover. Longer rides justify higher rates of mechanical ventilation.

Air Distribution

With overhead equipment, air is distributed through linear ceiling diffusers that are often constructed as a part of the overhead lighting fixtures. Undercar equipment usually makes use of the void spaces in the sidewalls and below fixed seating. In all cases, the

spaces used for air supply must be adequately insulated to prevent condensation on surfaces and, in the case of voids below seating, to avoid cold seating surfaces. The supply air discharge from undercar systems is typically through a windowsill diffuser. Recirculation air from overhead equipment flows through ceiling-mounted grilles. For undercar systems, return air grilles are usually found in the door wells or beneath seats.

Because of the vehicle's typical small size and low ceilings, care must be taken to design the air supply so that it does not blow directly on passengers' heads or shoulders. High rates of diffusion are needed, and diffuser placement and arrangement should cause the discharge to hug the ceiling and walls of the car. Total air quantity and discharge temperature must be carefully calculated to provide passenger comfort.

REFERENCES

- Andre, J.C.S., E.Z.E. Conceição, M.C.G. Silva, and D.X. Viegas. 1994. Integral simulation of air conditioning in passenger buses. Fourth International Conference on Air Distribution in Rooms (ROOMVENT 94).
- ASHRAE. 2001. Ventilation for acceptable indoor air quality. ANSI/ASHRAE *Standard* 62-2001.
- ASHRAE. 1992. Thermal environmental conditions for human occupancy. ANSI/ASHRAE *Standard* 55-1992.
- Giles, G.R., R.G. Hunt, and G.F. Stevenson. 1997. Air as a refrigerant for the 21st century. *Proceedings ASHRAE/NIST Refrigerants Conference, Refrigerants for the 21st Century*.
- Jones, B.W. and Q. He. 1993. *User manual: Transient human heat transfer model (includes application TRANMOD)*. Institute of Environmental Research, Kansas State University, Manhattan.
- Jones, B.W., Q. He, J.M. Sipes, and E.A. McCullough. 1994. The transient nature of thermal loads generated by people. *ASHRAE Transactions* 100(2):432-438.
- SAE. 1999. Safety and containment of refrigerant for mechanical vapor compression systems used for mobile air-conditioning systems. *Standard* J639. SAE International, Warrendale, PA.

BIBLIOGRAPHY

- APTA. 1999. Standard bus procurement guidelines for high floor diesel. American Public Transportation Association, Washington, D.C.
- APTA. 2000. Standard bus procurement guidelines for low floor diesel. American Public Transportation Association, Washington, D.C.
- Conceição, E.Z.E., M.C.G. Silva, and D.X. Viegas. 1997. Airflow around a passenger seated in a bus. *International Journal of HVAC&R Research* 3(4):311-323.
- Conceição, E.Z.E., M.C.G. Silva, and D.X. Viegas. 1997. Air quality inside the passenger compartment of a bus. *Journal of Exposure Analysis & Environmental Epidemiology* 7:521-534.
- Silva, M.C.G. and D.X. Viegas. 1994. External flow field around an intercity bus. Second International Conference on Experimental Fluid Mechanics.