

CHAPTER 31

KITCHEN VENTILATION

Cooking Effluent	System Integration and Balancing
Exhaust Hoods	Energy Considerations
Exhaust Systems	Fire Protection
Replacement (Makeup) Air	Operation and Maintenance
Systems	Residential Kitchen Ventilation
	31.11
	31.14
	31.15
	31.18
	31.19

KITCHEN ventilation is a complex application of HVAC systems. System design includes aspects of air conditioning, fire safety, ventilation, building pressurization, refrigeration, air distribution, and food service equipment. Kitchens are in many buildings, including restaurants, hotels, hospitals, retail malls, single- and multifamily dwellings, and correctional facilities. Each of these building types has special requirements for its kitchens, but many basic needs are common to all.

Kitchen ventilation has at least two purposes: (1) to provide a comfortable environment in the kitchen and (2) to enhance the safety of personnel working in the kitchen and of other building occupants. Comfort criteria often depend on the local climate; some kitchens are not air conditioned. The ventilation system can also affect the acoustics of a kitchen. Kitchen ventilation enhances safety by removing combustion products from gas- or solid-fueled equipment.

The centerpiece of almost any kitchen ventilation system is an exhaust hood, used primarily to remove effluent from kitchens. Effluent includes gaseous, liquid, and solid contaminants produced by the cooking process, and may also include products of fuel and even food combustion. These contaminants must be removed for both comfort and safety; effluent can be potentially life-threatening and, under certain conditions, flammable. The arrangement of food service equipment and its coordination with the hood(s) greatly affect kitchen operating costs.

HVAC system designers are most frequently involved in commercial kitchen applications, in which cooking effluent contains large amounts of grease or water vapor. Residential kitchens typically use a totally different type of hood. The amount of grease produced in residential applications is significantly less than in commercial applications, so the health and fire hazard is much lower.

COOKING EFFLUENT

Effluent Generation

As heat is applied to food in cooking, effluent is released into the surrounding atmosphere. This effluent includes thermal energy (as a convective plume and as heat radiated from the appliance to the kitchen space) that has not transferred to the food, water vapor, and/organic material released from the food. The energy source for the appliance, especially if it involves combustion, may release additional contaminants.

All cooking methods release some heat, some of which radiates from hot surfaces, and some that is dissipated by natural convection via a rising **plume** of heated air. The fraction of appliance energy input that is released to form a thermal (convective) plume can vary from approximately 50 to 90%. Typically, most of the effluent released from the food and the heat source is entrained in this plume, so primary contaminant control is based on capturing and removing the air and effluent that constitute the plume by using exhaust

ventilation. However, heat radiated to the space from the appliance is largely unaffected by ventilation and must be addressed by the space air-conditioning system. [Chapter 29 of the ASHRAE Handbook—Fundamentals](#) lists typical space heat gain values for many commercial kitchen appliances.

Effluent from five types of commercial cooking equipment has been measured under a typical exhaust hood (Kuehn et al. 1999). Foods that emit relatively large amounts of grease were selected. [Figure 1](#) shows the measured amount of grease in the plume entering the hood above different appliances and the amount in the vapor phase, particles below 2.5 μm in size (PM 2.5), particles less than 10 μm in size (PM 10), and the total amount of particulate grease. Ovens and fryers generate little or no grease particulate emissions, whereas other processes generate significant amounts. However, underfired broilers generate much smaller particulates compared to the griddles and ranges, and these emissions depend on the broiler design. The amount of grease in the vapor phase is significant and varies from 30% to over 90% by mass; this affects the design approach for grease removal systems.

CO and CO₂ emissions are present in solid fuel and natural gas combustion processes but not in processes from electrical appliances. Additional CO and CO₂ emissions may be generated by underfired boilers when grease drippings land on extremely hot surfaces and burn. NO_x emissions appear to be exclusively associated with gas appliances; emission level is related to total gas consumption.

[Figure 2](#) shows the measured plume volumetric flow rate entering the hood. In general, gas appliances have larger flow rates than electric because additional products of combustion must be vented. Underfired broilers have plume flow rates considerably larger than the other appliances shown. The effluent flow rates from underfired broilers are approximately 100 times larger than the actual volumetric flow rate created by vaporizing moisture and grease from food.

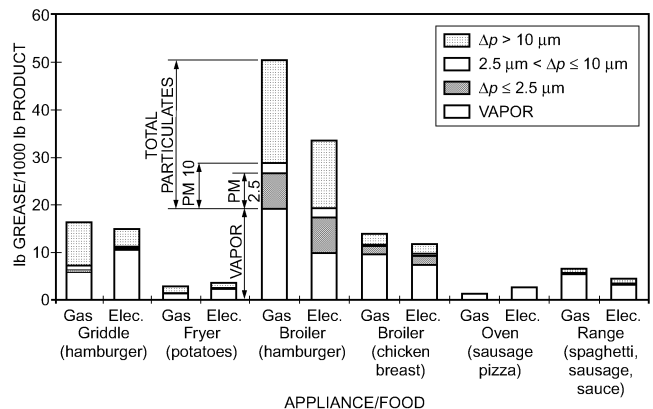

Fig. 1 Grease in Particle and Vapor Phases Emitted by Selected Commercial Cooking Appliances and Food Products
 Source: Kuehn et al. (1999)

The preparation of this chapter is assigned to TC 5.10, Kitchen Ventilation.

The difference is caused by ambient air entrained into the effluent plume before it reaches the exhaust hood.

Thermal Plume Behavior

The most common method of contaminant control is to install an air inlet device (a hood) where the plume can enter it and be conveyed away by an exhaust system. The hood is generally located above or behind the heated surface to intercept normal upward flow. Understanding plume behavior is central to designing effective ventilation systems.

Effluent released from a noncooking cold process, such as metal grinding, is captured and removed by placing air inlets so

that they catch forcibly ejected material, or by creating airstreams with sufficient velocity to induce the flow of effluent into an inlet. This technique has led to an empirical concept of **capture velocity** that is often misapplied to hot processes. Effluent (such as grease and smoke from cooking) released from a hot process and contained in a plume may be captured by locating an inlet hood so that the plume flows into it by buoyancy. Hood exhaust rate must equal or slightly exceed plume volumetric flow rate, but the hood need not actively induce capture of the effluent if the hood is large enough at its height above the cooking operation to encompass the plume as it expands during its rise. Additional exhaust airflow may be needed to resist cross-currents that carry the plume away from the hood.

A heated plume, without cross-currents or other interference, rises vertically, entraining additional air, which causes the plume to enlarge and its average velocity and temperature to decrease. If a surface parallel to the plume centerline (e.g., a back wall) is nearby, the plume will be drawn toward the surface by the **Coanda effect**. This tendency may also help direct the plume into the hood. [Figure 3](#) illustrates a heated plume with and without cooking effluent as it rises from heated cooking appliances. [Figure 3A](#) shows two charbroilers cooking hamburgers under a wall-mounted, exhaust-only, canopy hood. Note that the hood is mounted against a clear backwall to improve experimental observation. [Figures 3B](#) and [3C](#) show the hot air plume without cooking, visualized using a schlieren optical system, under full capture and spillage conditions, respectively.

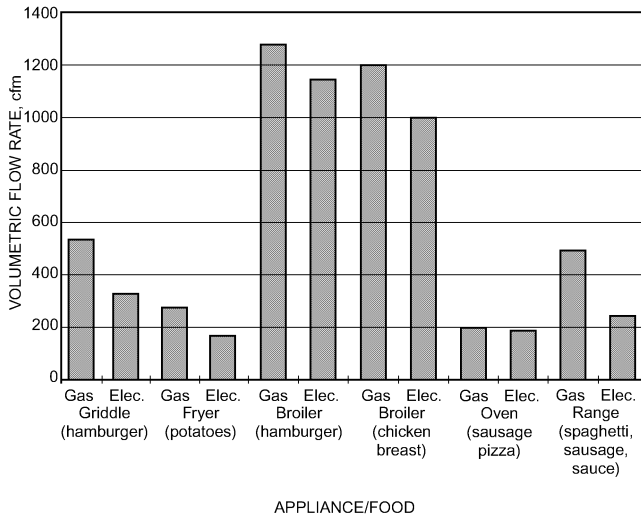

EXHAUST HOODS

The design, engineering, construction, installation, and maintenance of commercial kitchen exhaust hoods are controlled by nationally recognized standards [e.g., National Fire Protection Association (NFPA) *Standard 96*] and model codes [e.g., International Mechanical Code (IMC)]. In some cases, local codes may prevail. Before designing a kitchen ventilation system, the designer should identify governing codes and consult the authority with jurisdiction. Local authorities with jurisdiction may have amendments or additions to these standards and codes.

Fig. 2 Plume Volumetric Flow Rate at Hood Entrance from Various Commercial Cooking Appliances

Source: Kuehn et al. (1999)



A. TEST SETUP: Two charbroilers under 8 ft long wall-mounted canopy hood, cooking hamburgers.

B. Schlieren photo of capture and containment at 3600 cfm exhaust rate. Hot, clear air visualization, no cooking.

C. Schlieren photo of spillage and containment at 2400 cfm exhaust rate. Hot, clear air visualization, no cooking.

Fig. 3 Hot-Air Plume from Cooking Appliances under Wall-Mounted Canopy Hood

Hood Types

Many types, categories, and styles of hoods are available, and selection depends on many factors. Hoods are classified by whether they are designed to handle grease; Type I hoods are designed for removing grease and smoke, and Type II are not. Model codes distinguish between grease-handling and non-grease-handling hoods, but not all model codes use Type I/Type II terminology. A Type I hood may be used where a Type II hood is required, but the reverse is not allowed. However, characteristics of the equipment and processes under the hood, and not necessarily the hood type, determine the requirements for the entire exhaust system, including the hood.

A **Type I hood** is used for collecting and removing grease and smoke. It includes (1) listed grease filters, baffles, or extractors for removing the grease and (2) fire-suppression equipment. Type I hoods are required over restaurant equipment, such as ranges, fryers, griddles, broilers, and ovens, that produce smoke or grease-laden vapors.

A **Type II hood** collects and removes steam, vapor, heat, and odors where grease is not present. It may or may not have grease filters or baffles and typically does not have a fire-suppression system. It is typically used over dishwashers, steam tables, and so forth. A Type II hood is sometimes used over ovens, steamers, or kettles if they do not produce smoke or grease-laden vapor and if the authority having jurisdiction allows it.

Type I Hoods

Categories. Type I hoods fall into two categories: unlisted and listed. **Unlisted hoods** meet the design, construction, and performance criteria of applicable national and local codes and are not allowed to have fire-actuated exhaust dampers. **Listed hoods** are listed in accordance with Underwriters Laboratories (UL) *Standard 710*. Listed hoods are not generally designed, constructed, or operated in accordance with model code requirements, but are constructed in accordance with the terms of the hood manufacturer's listing; model codes include exceptions for listed hoods to show equivalency with the safety criteria of model code requirements.

The two basic subcategories of Type I listed hoods, as defined in UL *Standard 710*, are exhaust hoods with and without exhaust dampers. The UL listings do not distinguish between water-wash and dry hoods; however, water-wash hoods with fire-actuated water systems are identified in UL's product directory.

All listed hoods are subjected to electrical, temperature, and fire and cooking smoke capture tests. A listed exhaust hood with exhaust damper includes a fire-actuated damper, typically at the exhaust duct collar (and at the replacement air duct collar, depending on the hood configuration). In the event of a fire, the damper closes to prevent fire from entering the duct. Fire-actuated dampers are permitted only in listed hoods.

Listed exhaust hoods with fire-actuated water systems are typically water-wash hoods in which the wash system also operates as a fire-extinguishing system. In addition to meeting UL *Standard 710* requirements, these hoods are tested under UL *Standard 300* and may be listed for plenum extinguishing, duct extinguishing, or both.

Grease Removal. Most grease removal devices in Type I hoods operate on the same general principle: exhaust air passes through a series of baffles that create a centrifugal force to throw grease particles out of the airstream as the exhaust air passes around the baffles. The amount of grease removed varies with baffles design, air velocity, temperature, type of cooking, and other factors. A recognized test protocol is not available at present. NFPA does not allow mesh filters to be used as listed grease filters. Additionally, mesh filters cannot meet the requirements of UL *Standard 1046* and therefore cannot be used as primary grease filters. Grease removal devices generally fall into the following categories:

- A **baffle filter** is a series of vertical baffles designed to capture grease and drain it into a container. The filters are arranged in a channel or bracket for easy insertion and removal for cleaning.

Each hood usually has two or more baffle filters, which are typically constructed of aluminum, steel, or stainless steel and come in various standard sizes. Filters are cleaned by running them through a dishwasher or by soaking and rinsing. NFPA *Standard 96* requires that grease filters be listed. Listed grease filters are tested and certified by a nationally recognized test laboratory under UL *Standard 1046*.

- **Removable extractors** are integral components of listed exhaust hoods designed to use them. They are typically constructed of stainless steel and contain a series of horizontal baffles designed to remove grease and drain it into a container. Available in various sizes, they are cleaned by running them through a dishwasher or by soaking and rinsing.
- **Stationary extractors** (also called a water-wash hood), integral to the listed exhaust hoods that use them, are typically constructed of stainless steel and contain a series of horizontal baffles that run the full length of the hood. The baffles are not removable for cleaning. The stationary extractor includes one or more water manifolds with spray nozzles that, upon activation, wash the grease extractor with hot, detergent-injected water, removing accumulated grease. The wash cycle is typically activated at the end of the day, after the cooking equipment and fans have been turned off; however, it can be activated more frequently. The cycle lasts 5 to 10 min, depending on the hood manufacturer, type of cooking, duration of operation, and water temperature and pressure. Most water-wash hood manufacturers recommend a water temperature of 130 to 180°F and water pressure of 30 to 80 psi. Average water consumption varies from 0.50 to 1.50 gpm per linear foot of hood, depending on manufacturer. Most water-wash hood manufacturers provide a manual and/or automatic means of activating the water-wash system in the event of a fire.

Some water-wash hood manufacturers provide continuous cold water as an option. The cold water runs continuously during cooking and may or may not be recirculated, depending on the manufacturer. Typical cold water usage is 1 gph per linear foot of hood. The advantage of this method is that it improves grease extraction and removal, partly through condensation of the grease. Many hood manufacturers recommend continuous cold water in hoods located over solid-fuel-burning equipment, because the water also extinguishes hot embers that may be drawn up into the hood and helps cool the exhaust stream.

UL *Standards 1046* and *710* do not include grease extraction tests because no industry-accepted tests are available at present. Grease extraction rates published by filter and hood manufacturers are usually derived from tests conducted by independent test laboratories retained by the manufacturer. Test methods and results therefore vary greatly.

Styles. [Figure 4](#) shows the six basic hood styles for Type I applications. These style names are not used universally in all standards and codes but are well accepted in the industry. The styles are as follows:

- **Wall-mounted canopy**, used for all types of cooking equipment located against a wall.
- **Single-island canopy**, used for all types of cooking equipment in a single-line island configuration.
- **Double-island canopy**, used for all types of cooking equipment mounted back-to-back in an island configuration.
- **Back shelf**, used for counter-height equipment typically located against a wall, but possibly freestanding.
- **Eyebrow**, used for direct mounting to ovens and some dishwashers.
- **Pass-over**, used over counter-height equipment when pass-over configuration (from the cooking side to the serving side) is required.

Sizing. The size of the exhaust hood relative to cooking appliances is important in determining hood performance. Usually the

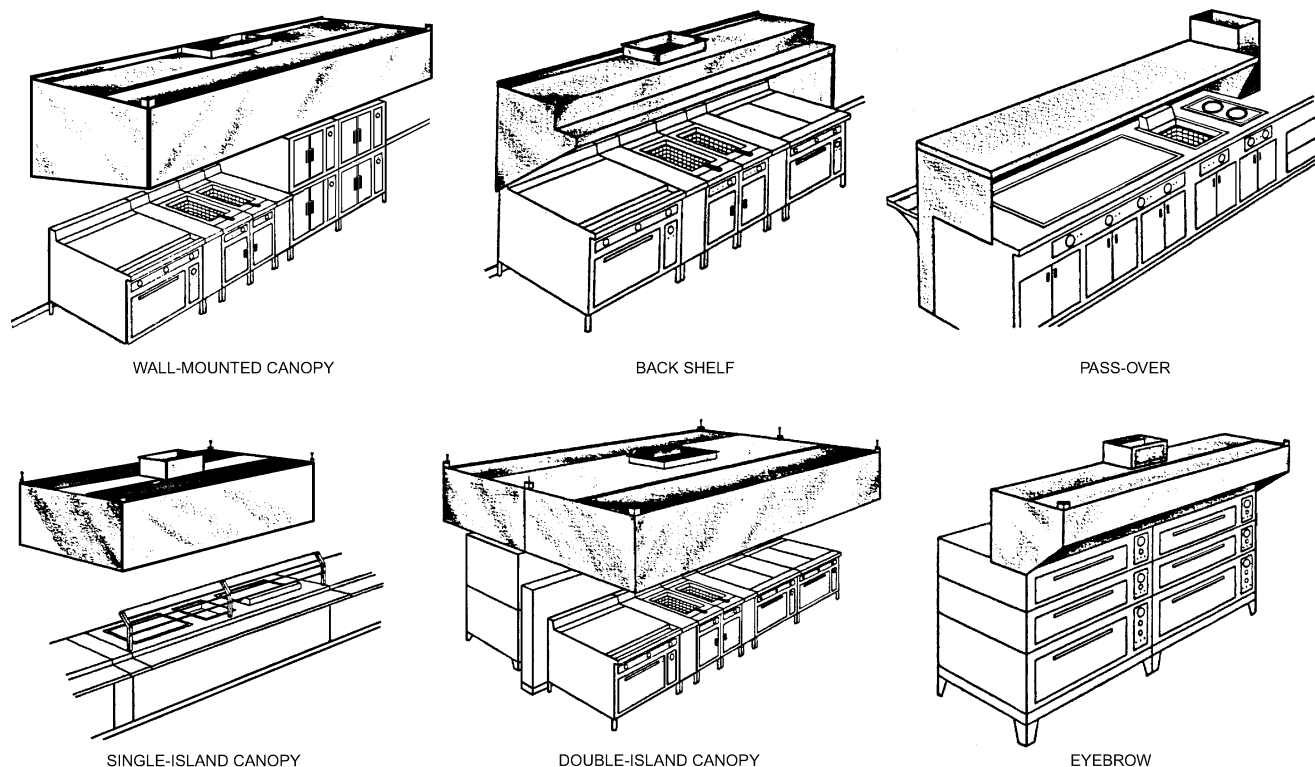

Fig. 4 Styles of Commercial Kitchen Exhaust Hoods

Table 1 Minimum Overhang Requirements for Type I Hoods

Type of Hood	End Overhang, in.	Front Overhang, in.	Rear Overhang, in.
Wall-mounted canopy	6	6	—
Single-island canopy	6	6	6
Double-island canopy	6	6	—
Eyebrow	—	6	—
Back shelf/Pass-over	6	10 (setback)*	—

Note: Model codes typically require 6 in. minimum overhang, but most manufacturers design for 12 in. overhang.
 *Maximum.

hood must extend horizontally beyond the cooking appliances (on all open sides on canopy-style hoods and over the ends on back shelf and pass-over hoods) to capture expanding thermal currents rising from the appliances. This **overhang** varies with the hood style, distance between the hood and cooking appliance, and characteristics of the cooking equipment. With back shelf and pass-over hoods, the front of the hood must be kept behind the front of the cooking equipment (**setback**) to allow head clearance for the cooks. These hoods may require a higher front inlet velocity to catch and contain expanding thermal currents. All styles may have full or partial side panels to close the area between appliances and the hood. This may eliminate the overhang requirement and generally reduces the exhaust flow rate requirement.

For unlisted hoods, size is dictated by the prevailing model code; for listed hoods, by the terms of the manufacturer’s listing. Typically, overhang requirements applied to listed hoods are similar to those for unlisted hoods. Minimum overhang requirements are shown in [Table 1](#).

Exhaust Flow Rates. Exhaust flow rate requirements to capture, contain, and remove effluent vary considerably depending on hood style, overhang, distance from cooking surfaces to hood, presence

Table 2 Appliance Types by Duty Category

Light duty (400°F)	Electric or gas	Ovens (including standard, bake, roasting, revolving, retherm, convection, combination convection/steamer, conveyor, deck or deck-style pizza, pastry)
		Steam-jacketed kettles
		Compartment steamers (both pressure and atmospheric)
		Cheesemelters
		Rethermalizers
		Discrete element ranges (with or without oven)
Medium duty (400°F)	Electric or gas	Hot-top ranges
		Griddles
		Double-sided griddles
		Fryers (including open deep-fat fryers, donut fryers, kettle fryers, pressure fryers)
		Pasta cookers
		Conveyor (pizza) ovens
Heavy duty (600°F)	Gas Electric or gas	Tilting skillets/braising pans
		Rotisseries
		Open-burner ranges (with or without oven)
		Underfired broilers
		Chain (conveyor) broilers
		Wok ranges
Extra-heavy duty (700°F)	Salamanders	Overfired (upright) broilers
		Appliances using solid fuel such as wood, charcoal, briquettes, and mesquite to provide all or part of the heat source for cooking.

and size of side panels, cooking equipment, food, and cooking processes involved. The hot cooking surfaces and product vapors create thermal air currents that are received or captured by the hood and

Table 3 Exhaust Flow Rates by Cooking Equipment Category for Unlisted and Listed Type

Type of Hood	Minimum Exhaust Flow Rate, cfm per linear foot of hood			
	Light Duty	Medium Duty	Heavy Duty	Extra-Heavy Duty
Wall-mounted canopy, unlisted	200	300	400	550
listed	150 to 200	200 to 300	200 to 400	350+
Single-island, unlisted	400	500	600	700
listed	250 to 300	300 to 400	300 to 600	550+
Double-island (per side), unlisted	250	300	400	550
listed	150 to 200	200 to 300	250 to 400	500+
Eyebrow, unlisted	250	250	Not allowed	Not allowed
listed	150 to 250	150 to 250	—	—
Back shelf/Pass-over, unlisted	300	300	400	Not allowed
listed	100 to 200	200 to 300	300 to 400	Not recommended

Source: ASHRAE Standard 154P

then exhausted. The velocity of these currents depends largely on surface temperature and tends to vary from 15 fpm over steam equipment to 150 fpm over charcoal broilers. The required flow rate is determined by these thermal currents, a safety allowance to absorb cross-currents and flare-ups, and a safety factor for the style of hood.

Overhang and the presence or absence of side panels help determine the safety factor for different hood styles. Gas-fired cooking equipment may require an additional allowance for exhaust of combustion products and combustion air. Table 1 shows minimum overhangs.

Because it is not practical to place a separate hood over each piece of equipment, general practice (reflected in ASHRAE Standard 154P) is to categorize equipment into four groups, as shown in Table 2.

These categories apply to unlisted and listed Type I hoods. The exhaust volumetric flow rate requirement is based on the group of equipment under the hood. If there is more than one group, the flow rate is based on the heaviest-duty group unless the hood design permits different rates over different sections of the hood.

Though considered obsolete based on laboratory research, some local codes may still require exhaust flow rates for unlisted canopy hoods to be calculated by multiplying the horizontal area of the hood opening by a specified air velocity. Some jurisdictions may use the length of the open perimeter of the hood times the vertical height between the hood and the appliance instead of the horizontal hood area. Research (Swierczyna et al. 1997) indicates that these methods of calculation result in higher-than-necessary exhaust flow rates for deeper hoods, because the larger reservoirs of deeper hoods typically increase hood capture and containment performance.

Table 3 lists recommended exhaust flow rates by equipment duty category for unlisted hoods and typical design rates for listed hoods. The rates for unlisted hoods are based on ASHRAE Standard 154P. The typical design rates for listed hoods are based on published rates for listed hoods serving single categories of equipment, which vary from manufacturer to manufacturer. Listed rates are usually lower than those for unlisted hoods, and it is generally advantageous to specify listed hoods.

Listed hoods are allowed to operate at their listed exhaust flow rates by exceptions in the model codes. Most manufacturers of listed hoods verify their listed flow rates by conducting tests per UL Standard 710. Typically, average flow rates are much lower than those dictated by the model codes. Note that listed values are established under draft-free laboratory conditions, and actual operating conditions may compromise listed performance. Thus, manufacturers may recommend design values above their listed values.

Hoods listed in accordance with UL Standard 710 cover one or more cooking equipment temperatures: 400, 600 and 700°F. In application, these temperature ratings correspond to duty ratings (see Table 2). Each temperature ratings has an air quantity factor

Table 4 Exhaust Static Pressure Loss of Type I Hoods for Various Exhaust Airflows

Type of Grease Removal Device	Hood Static Pressure Loss, in. of water			
	150 to 250 cfm/ft	250 to 350 cfm/ft	350 to 450 cfm/ft	500+ cfm/ft
Baffle filter	0.25 to 0.50	0.50 to 0.75	0.75 to 1.00	1.00+
Extractor	1.00 to 1.35	1.30 to 1.70	1.70+	1.70+

assigned to the hood. The total exhaust flow rate is typically calculated by multiplying the hood air quantity factor by hood length.

Actual exhaust flow rates for hoods with internal short-circuit replacement air are typically higher than those in Table 4, although net exhaust (actual exhaust less internal replacement air quantity) may be similar or even lower. The specific hood manufacturer should be contacted for exact exhaust and replacement flow rates.

ASTM Standard F1704 details a laboratory flow visualization procedure for determining the capture and containment threshold of an appliance/hood system. This procedure can be applied to all hood types and configurations operating over any cooking appliances. Standard F1704 also provides a laboratory test procedure for determining heat gain of specific combinations of exhaust system, cooking equipment, foods, and cooking processes. Results from a series of interlab heat gain tests (Fisher 1998) have been incorporated in Chapter 29 of the ASHRAE Handbook—Fundamentals.

Replacement (Makeup) Air Options. Air exhausted from the kitchen must be replaced. Replacement air can be brought in through traditional methods, such as ceiling diffusers, or through systems built as an integral part of the hood. It may also be introduced using low-velocity displacement diffusers or transfer air from other zones. For further information, see the section on Replacement (Makeup) Air Systems.

Static Pressure. The static pressure drop through hoods depends on the type and design of the hood and grease removal devices, size of duct connections, and flow rate. Table 4 provides a general guide for determining static pressure loss depending on the type of grease removal device and exhaust flow rate. Manufacturers' data should be consulted for actual values. Static pressure losses for exhaust ductwork downstream of the hood collar should be calculated for each installation.

Type II Hoods

Type II hoods (Figure 5) can be divided into the following two application categories:

- **Condensate hood.** For applications with high-moisture exhaust, condensate forms on interior surfaces of the hood. The hood is designed to direct the condensate toward a perimeter gutter for collection and drainage, allowing none to drip onto the appliance below. Flow rates are typically based on 50 to 75 cfm per square

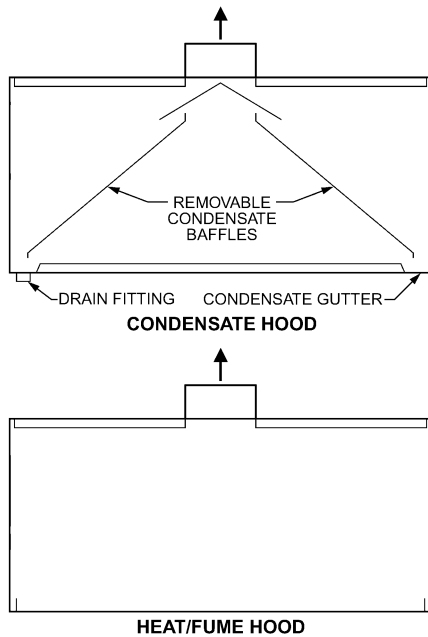

Fig. 5 Type II Hoods

foot of hood opening. Hood material is usually noncorrosive, and filters are usually installed.

- **Heat/fume hood.** For hoods over equipment producing heat and fumes only, flow rates are typically based on 50 to 100 cfm per square foot of hood opening. Filters are usually not installed.

Recirculating Hoods

A recirculating hood, sometimes called a **ductless hood**, consists of a cooking appliance/hood assembly designed to remove grease, smoke, and odor and to exhaust the return air directly back into the room. These hoods typically contain the following components in the exhaust stream: (1) a grease removal device such as a baffle filter, (2) a high-efficiency particulate air (HEPA) filter or an electrostatic precipitator (ESP), (3) some means of odor control such as activated charcoal, and (4) an exhaust fan. NFPA *Standard 96*, Chapter 10, is devoted entirely to recirculating hoods and contains specific requirements such as (1) design, including interlocks of all critical components to prevent operation of the cooking appliance if any of the components are not operating; (2) fire extinguishing, including specific nozzle locations; (3) maintenance, including a specific schedule for cleaning filters, ESPs, hoods, and blowers; and (4) inspection and testing of the total operation and interlocks. In addition, NFPA *Standard 96* requires that all recirculating hoods be listed by a testing laboratory. The recognized test standard for a recirculating hood is UL *Standard 197*. Ductless hoods should not be used over gas-fired or solid-fuel-fired equipment, which must be exhausted directly to the outside to remove combustion products.

Designers should thoroughly review NFPA *Standard 96* requirements and contact a manufacturer of recirculating hoods to obtain specific information and actual UL *Standard 197* test data before incorporating this type of hood into a food service design. Note that recirculating hoods discharge the total heat and moisture of the cooking operation back into the kitchen space, adding to the air-conditioning load.

EXHAUST SYSTEMS

Exhaust systems remove effluent from appliances and cooking processes to promote fire and health safety, comfort, and aesthetics. Typical exhaust systems simultaneously incorporate fire prevention

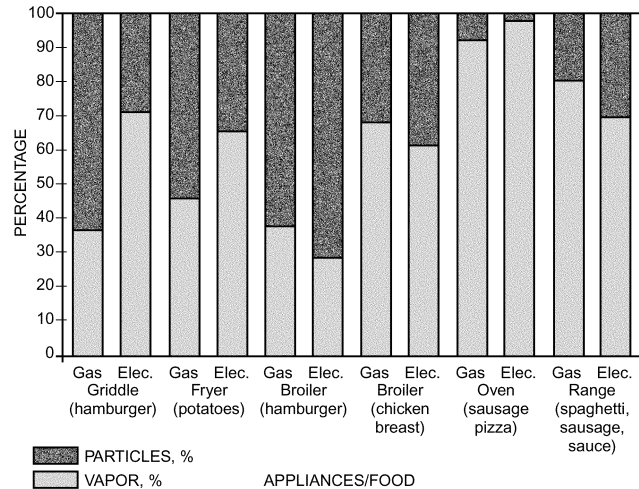

Fig. 6 Particulate Versus Vapor-Phase Emission Percentage per Appliance (Average)

Source: ASHRAE RP-745

designs and fire suppression equipment. In most cases, these functions complement each other, but in other cases they may seem to conflict. Designs must balance the functions. For example, fire-actuated dampers may be installed to minimize the spread of fire to ducts, but maintaining an open duct might be better for removing the smoke of an appliance fire from the kitchen.

Effluent Control

Effluents generated by cooking include grease in particulate (solid or liquid) and vapor states, smoke particles, and volatile organic compounds (VOCs or low-carbon aromatics, which are significant contributors to odor). Effluent controls in the vast majority of kitchen ventilation systems are limited to removing solid and liquid grease particles by mechanical grease removal devices in the hood. More effective devices reduce grease buildup downstream of the hood, lowering the frequency of duct cleaning and reducing the fire hazard. Higher-efficiency grease removal devices increase the efficiency of smoke and odor control equipment, if present.

The reported grease extraction efficiency of mechanical filtration systems (e.g., baffle filters and slot cartridge filters) may not reflect actual performance. These devices are tested and listed for their ability to limit flame penetration into the plenum and duct, not their grease extraction performance. Research indicates that particulate grease consists of small, aerodynamic particles that are not easily removed by centrifugal impingement, as used in most grease extraction devices (Kuehn et al. 1999). If these particles must be removed, a particulate removal unit is typically added, which removes a large percentage of the grease that escaped the grease removal device in the hood, as well as smoke particles.

Research also indicates that a significant proportion of grease effluent may be in vapor form (Figure 6), which is not removed by centrifugal means. Mechanical extraction is not effective in removing vapor.

Concerns about air quality have also emphasized the need for higher-efficiency grease extraction from the exhaust airstream than can be provided by filters or grease extractors in exhaust hoods. Cleaner exhaust discharge to outside may be required by increasingly stringent air quality regulations or where the exhaust discharge configuration is such that grease, smoke, or odors in discharge would create a nuisance. In some cases, exhaust air is cleaned so that it can be discharged inside (e.g., through recirculating hoods). Several systems have been developed to clean the

exhaust airstream, each of which presents special fire protection issues.

Where odor control is required in addition to grease removal, activated charcoal, other oxidizing bed filters, or deodorizing agents are used downstream of the grease filters. Because much cooking odor is gaseous and therefore not removed by air filtration, filtration upstream of the charcoal filters must remove virtually all grease in the airstream to prevent grease buildup on the charcoal filters.

The following technologies are available and applied to varying degrees for control of cooking effluent. They are listed by order of use in the exhaust stream after a mechanical filtration device, with particulate control upstream of VOC control. After the description of each technology are qualifications and concerns about its use. There is no consensus test protocol for evaluating these technologies in kitchen applications.

Electrostatic precipitators (ESPs). Particulate removal is by high-voltage ionization, then collection on flat plates.

- Condensed grease can block airflow, especially when mounted outside.
- As the ionizer section becomes dirty, efficiency drops because the effective ionizer surface area is reduced.
- Under heavy loading conditions, the unit may shut down because of voltage drop.

Ultraviolet (UV) destruction. The system uses ultraviolet light with or without ozone to chemically convert the grease into an inert substance.

- Requires adequate exposure time for chemical reactions.
- Personnel should not look at light generated by high-intensity UV lamps.
- Exhaust fans should operate when UV lights are on because some forms of UV generate ozone.
- UV is more effective on very small particles and vapor.
- The required frequency of duct cleaning is reduced.
- Lamps need to be replaced periodically; as lamps become dirty, efficiency drops.

Water mist, scrubber, and water bath. Passage of the effluent stream through water mechanically entraps particulates and condenses grease vapor.

- High airflow can reduce efficiency of water baths.
- Water baths have high static pressure loss.
- Spray nozzles need much attention; water may need softening to minimize clogging.
- Drains tend to become clogged with grease, and grease traps require more frequent service. Mist and scrubber sections need significant length to maximize exposure time.

Pleated, bag, and HEPA filters. These devices are designed to remove very small particles by mechanical filtration. Some types also have an activated-carbon face coating for odor control.

- Filters become blocked quickly if too much grease enters.
- Static loss builds quickly with extraction, and airflow drops.
- Almost all filters are disposable and very expensive.

Activated-carbon filters. VOC control is through adsorption by fine activated charcoal particles.

- Require a large volume and thick bed to be effective.
- Are heavy and can be difficult to replace.
- Expensive to change and recharge. Many are disposable.
- Ruined quickly if they are grease-coated or subjected to water.
- Some concern that carbon is a source of fuel for a fire.

Oxidizing pellet bed filters. VOC and odor control is by oxidation of gaseous effluent into solid compounds.

- Require a large volume and long bed to be effective.

- Are heavy to handle and can be difficult to replace.
- Expensive to change.
- Some concern about increased oxygen available in fire.

Incineration. Particulate, VOC, and odor control is by high-temperature oxidation (burning) into solid compounds.

- Must be at system terminus and clear of combustibles.
- Are expensive to install with adequate clearances.
- Can be difficult to access for service.
- Very expensive to operate.

Catalytic conversion. A catalytic or assisting material, when exposed to relatively high-temperature air, provides additional heat adequate to decompose (oxidize) most particulates and VOCs.

- Requires high temperature (450°F minimum).
- Expensive to operate due to high temperature requirement.

Duct Systems

Exhaust ductwork conveys exhaust air from the hood to the outside, along with any grease, smoke, VOCs, and odors that are not extracted from the airstream along the way. This ductwork may also be used to exhaust smoke from a fire. To be effective, ductwork must be greasetight; it must be clear of combustibles, or combustible material must be protected so that it cannot be ignited by a fire in a duct; and ducts must be sized to convey the volume of airflow necessary to remove the effluent. Model building codes, such as the IMC, and standards, such as NFPA *Standard 96*, have set minimum air velocity for exhaust ducts at 1500 fpm. Maximum velocities are limited by pressure drop and noise and typically do not exceed 2500 fpm. ASHRAE research (Kuehn 1998) indicates that there is no basis for specifying 1500 fpm minimum duct velocity for commercial kitchen ventilation, but rather supports reducing NFPA *Standard 96* recommendations to 500 fpm. This change allows flexibility for design of variable-speed exhaust systems and retrofitting older systems, though current design practice for new single-speed systems will generally continue to use design duct velocity around 1500 fpm.

Ductwork should have no traps that can hold grease, which would be an extra fuel source in the event of a fire, and ducts should pitch toward the hood or an approved reservoir for constant drainage of liquefied grease or condensates. On long duct runs, allowance must be made for possible thermal expansion because of fire, and the slope back to the hood or grease reservoir must conform to local code requirements.

Single-duct systems carry effluent from a single hood or section of a large hood to a single exhaust termination. In multiple-hood systems, several branch ducts carry effluent from several hoods to a single master duct that has a single termination. See the section on Multiple-Hood Systems for more information.

Ducts may be round or rectangular. Standards and model codes contain minimum specifications for duct materials, including gage, joining methods, and minimum clearances to combustible materials. UL-listed prefabricated duct systems may also be used; these systems typically allow clearance to combustible materials to be reduced.

Types of Exhaust Fans

Exhaust fans for kitchen ventilation must be capable of handling hot, grease-laden air. The fan should be designed to keep the motor out of the airstream and should be effectively cooled to prevent premature failure. To prevent roof damage, the fan should contain and properly drain all grease removed from the airstream.

The following types of exhaust fans are in common use (all have centrifugal wheels with backward-inclined blades):

- **Power roof ventilator (PRV).** Also known as **upblast** fans, PRVs are designed for mounting at the exhaust stack outlet ([Figure 7](#)),

and discharge upward or outward from the roof or building. Aluminum upblast fans must be listed for the service in compliance with UL *Standard 762*, and must include a grease drain, grease collection device, and integral hinge kit to permit access for duct cleaning.

- **Centrifugal fan.** Also known as a **utility set**, this is an AMCA Arrangement 10 centrifugal fan, including a field-rotatable blower housing, blower wheel with motors, drives, and often a motor/drive weather cover (Figure 8). These fans are typically constructed of steel and roof-mounted. Where approved, centrifugal fans can be mounted indoors and ducted to discharge outside. The inlet and outlet are at 90° to each other (single width, single inlet), and the outlet can usually be rotated to discharge at different angles around a vertical circle. The lowest part of the fan must drain to an approved container. When listed in accordance with UL *Standard 762*, a grease drain, grease collection device, and blower housing access panel are required.
- **Tubular centrifugal.** These fans, also known as **inline** fans, have the impeller mounted in a cylindrical housing discharging the gas in an axial direction (Figure 9). Where approved, these fans can be located in the duct run inside a building if exterior fan mounting is not practical for wall or roof exhaust. They are always constructed of steel. The gasketed flange mounting must be greasetight yet removable for service. The lowest part of the fan must drain to an approved container. When listed in accordance with UL *Standard 762* a grease drain, grease collection device, and blower housing access panel are required.

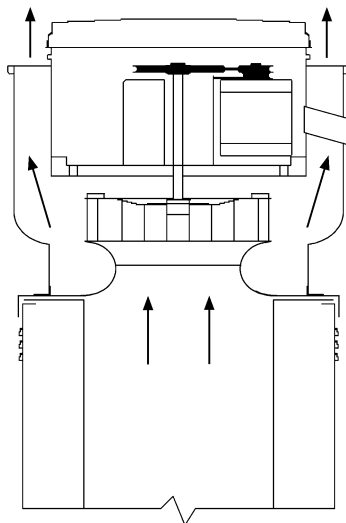

Fig. 7 Power Roof Ventilator (Upblast Fan)

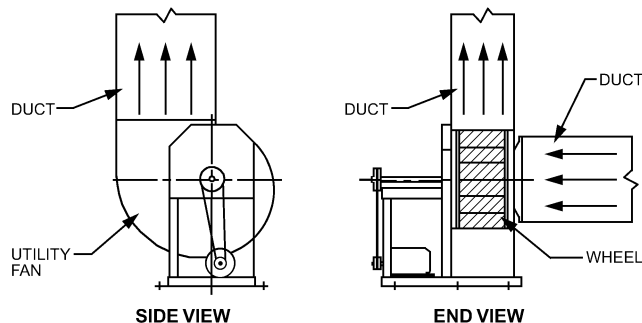

Fig. 8 Centrifugal Fan (Utility Set)

Exhaust Terminations

Rooftop. Rooftop terminations are preferred because discharge can be directed away from the building, the fan is at the end of the system, and the fan is accessible. Common concerns with rooftop terminations are as follows:

- Exhaust system discharge should be arranged to minimize reentry of effluent into any fresh-air intake or other opening to any building. This requires not only separating the exhaust from intakes, but also knowledge of the direction of the prevailing winds. Some codes specify a minimum distance to air intakes.
- In the event of a fire, neither flames, radiant heat, nor dripping grease should be able to ignite the roof or other nearby structures.
- All grease from the fan or duct termination should be collected and drained to a remote closed container to preclude ignition.
- Rainwater should be kept out of the exhaust system, especially out of the grease container. If this is not possible, then the grease container should be designed to separate water from grease and drain the water back onto the roof. Figure 10 shows a rooftop utility set with a stackhead fitting, which directs exhaust away from the roof and minimizes rain penetration. Discharge caps should not be used because they direct exhaust back toward the roof and can become grease-fouled.

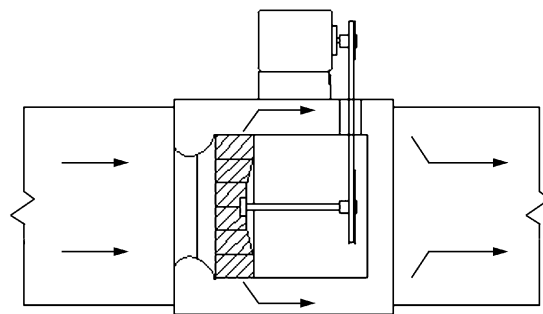

Fig. 9 Tubular Centrifugal (Inline) Fan

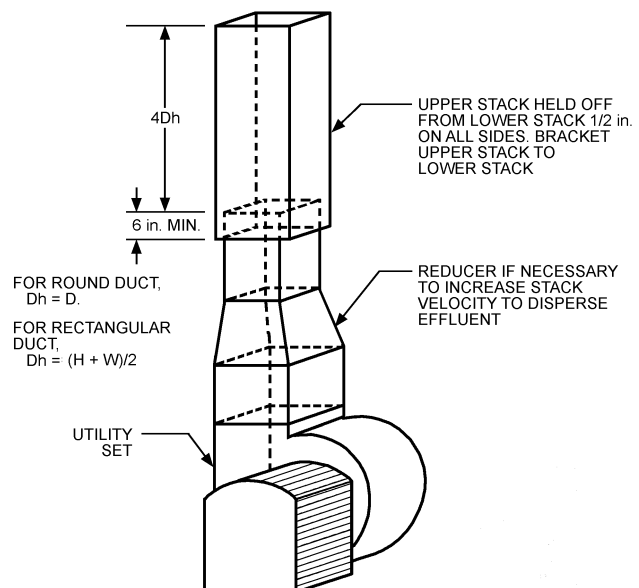

Fig. 10 Rooftop Centrifugal Fan (Utility Set) with Vertical Discharge

Outside Wall. Wall terminations are less common today but are still occasionally used in new construction. The fan may or may not be the terminus of the system, located on the outside of the wall. Common concerns with wall terminations are as follows:

- Discharge from the exhaust system should not be able to enter any fresh-air intake or other opening to any building.
- Adequate clearance to combustibles must be maintained.
- To avoid grease draining down the side of the building, duct sections should pitch back to the hood inside, or a grease drain should be provided to drain grease back into a safe container inside the building.
- Discharge must not be directed downward or toward any pedestrian areas.
- Louvers should be designed to minimize their grease extraction and to prevent staining of the building facade.

Recirculating Hoods. With these units, it is critical to keep components in good working order to maintain optimal performance. Otherwise, excessive grease, heat, and odors will accumulate in the premises.

As with other terminations, containing and removing grease and keeping the discharge as far as possible from combustibles are the main concerns. Some units are fairly portable and could be set in an unsafe location. The operator should be made aware of the importance of safely locating the unit. These units are best for large, unconfined areas with a separate outside exhaust to keep the environment comfortable.

REPLACEMENT (MAKEUP) AIR SYSTEMS

In hood systems, where air exhausted through the hood is discharged to the outside, the volume of air exhausted must be replaced with uncontaminated outside air. Outside air must be introduced into the building through properly designed replacement air systems. Proper replacement air volume and distribution allow the hood exhaust fan to operate as designed and facilitate proper building pressurization, which is required for safe operation of direct-vent gas appliances (such as water heaters), preventing kitchen odors migrating to adjacent building spaces, and maintaining a comfortable building environment. Proper pressurization enhances the building environment by preventing suction of unfiltered and/or unconditioned outside air into the building envelope through doors, windows, or air handlers. IMC requires neutral or negative pressurization in rooms with mechanical exhaust. NFPA *Standard 96* requires enough replacement air to prevent negative pressures from exceeding 0.02 in. of water, which may still be excessive for proper drafting of some direct vent appliances. To ensure pressure control, IMC also requires electrical interlock between exhaust and replacement air (makeup) sources. This electrical interlock prevents excessive negative or positive pressures created by the exhaust fan or replacement air unit operating independently.

Indoor Air Quality

Traditionally, the primary purpose of replacement air has been to ensure proper operation of the hood. Kitchen thermal comfort and indoor air quality (IAQ) have been secondary. In some applications, thermal comfort and IAQ can be improved through adequate airflow and proper introduction of replacement air. In many of today's applications, outside air that meets IAQ standards is the most energy-efficient source for kitchen hood replacement air. ASHRAE *Standard 62* requires that 20 cfm outside air per person, based on a maximum occupancy of 70 persons per 1000 ft² (100 persons per 1000 ft² for cafeterias and fast-food restaurants) be brought into the dining area. The requirement is 30 cfm per person in bars/cocktail lounges at 100 persons per 1000 ft². Kitchens require 15 cfm per person based on 20 persons per 1000 ft². These requirements may be increased or decreased in certain areas if approved by the

authority having jurisdiction. Outside air requirements sometimes affect HVAC system sizing and require another means of introducing outside air. A further requirement of *Standard 62*, that outside air be sufficient to provide for an exhaust rate of at least 1.5 cfm per square foot of kitchen space, is generally easily met.

Replacement Air Introduction

Replacement air may be introduced into the building through conventional HVAC apparatus, ventilators (no conditioning), or dedicated kitchen makeup air units and replacement air units. Replacement-air units are specifically designed to supply heated and/or cooled 100% outside air.

Conventional HVAC units used as replacement air sources may have fixed outside air intakes or economizer-controlled outside air dampers. HVAC units with economizers should have a barometric relief damper either in the return ductwork or in the HVAC unit itself. As the amount of outside air is increased, the increase in pressure in the system will open the relief damper, so that the return air volumetric rate is only enough to maintain approximately the amount of design supply air. The supply fan runs at a constant speed and thus moves a constant volume of air. The amount of air required for dedicated replacement air becomes the minimum set point for the economizer damper when the hoods are operating. Fixed outside air intakes must be set to allow the required amount of replacement air. Outside air dampers should be interlocked with hood controls to open to a preset minimum position when the hood system is energized. If the zone controls call for cooling, and outside conditions are within economizer range, the outside damper may be opened to allow greater amounts of outside air. The maximum setting for outside air dampers in unitary HVAC units is typically 25 to 30% of total unit air volume when compressors are running.

Operating in economizer mode should not change air discharge velocities or volumes, because the supply fan runs at a constant speed and thus moves a constant volume of air. However, field experience shows that large increases in air discharge velocities or volumes can occur at diffusers when HVAC units go into economizer mode. This is because the static loss through the fresh-air intake is considerably less than through the return air duct system, and thus a change from return air to fresh air reduces the overall static through the system, resulting in a relative increase in the total system flow. This can create air balance problems that negatively affect hood performance because of interference with capture and containment supply flow patterns at the hoods. A large increase in air velocity or volume from supply diffusers indicates a need for better balance between the fresh air and return air static losses. Some HVAC manufacturers state that a relief fan is required to ensure proper air balance if economizer controls call for outside air greater than 50% during economizer operation mode. A relief fan addresses static losses in the return duct system, thus helping minimize the static difference with the fresh-air intake. Lack of a barometric relief damper, or constrictions in the return ductwork, also may be the source of the problem.

In smaller commercial buildings, including restaurants and strip centers, individual unitary rooftop HVAC equipment is common. This unitary equipment may not be adequate to supply 100% of the replacement air volume. Outside air must be considered in the initial unit selection to obtain desired unit operation and space comfort. The space in which the hood is located should be maintained at a neutral or negative pressure relative to adjacent spaces. Therefore, HVAC economizers are not recommended for equipment supplying air directly to the space in which the hood is located, unless the economizer installation includes equipment and controls to maintain overall system air balance and to prevent excessive air discharge velocities or volumes.

Using of enthalpy or temperature control is recommended. These controls cycle HVAC compressor(s), water supply, or heat source off when outside air conditions warrant and open outside air dampers if

economizer controls are used. These additional controls provide kitchen comfort while conserving energy and saving money.

Replacement Air Categories

Three categories of replacement air have been defined for design of energy-efficient replacement air systems: supply, makeup, and transfer. IAQ engineers must design outside air systems to meet total building ventilation requirements. Replacement air for kitchen ventilation must integrate into the total building IAQ design. Total kitchen ventilation replacement air may consist of only dedicated makeup air; however, in many energy-efficient designs, outside air required for ventilating the kitchen or adjacent spaces is used as supply or transfer air to augment or even eliminate the need for dedicated makeup air. Typically, replacement air will be a combination of categories from multiple sources. The source of replacement air typically determines its category.

Supply air is outside air introduced through the HVAC or ventilating apparatus, dedicated to the comfort conditioning of the space in which the hood is located. In many cases this may be an ideal source of replacement air as it also provides comfort conditioning for the occupants.

Makeup air is outside air introduced through a system dedicated to provide replacement air specifically for the hood. It is typically delivered directly to or close to a compensating hood. This air may or may not be conditioned. When conditioned, it may be heated only; generally only in extreme environments will it be cooled. When included, makeup air typically receives less conditioning than space supply air. The IMC requires makeup air be conditioned to within 10°F of the kitchen space, except when introducing replacement air does not decrease kitchen comfort (see the section on Energy Considerations for additional information). This can be accomplished with proper distribution design. Typical sources of makeup air conditioning include electric resistance, direct and indirect gas-fired units, evaporative coolers, and water coils for cooling or heating (freeze protection required). Temperature of makeup air introduced varies with distribution system and type of operation.

Transfer air is outside air, introduced through the HVAC or ventilating apparatus, dedicated to comfort conditioning and ventilation requirements of a space adjacent to the hood. The device providing transfer air must be in operation and supplying outside air while the hood is operating. Air must not be transferred from spaces where airborne contaminants such as odors, germs, or dust may be introduced into the food preparation or serving areas. Air may be transferred through wall openings, door louvers, or ceiling grilles connected by duct above the ceiling. Depending on grille and duct pressure drop, a transfer fan(s) may be required to avoid drawing transfer air through lower-pressure-drop openings. When using openings through which food is passed, transfer velocities should not exceed 50 fpm to avoid excessive cooling of the food. Transfer air is an efficient source of replacement air because it performs many functions, including ventilating and/or conditioning the adjacent space, replacing air for the hood, and additional conditioning for the space in which the hood is located. Only the portion of air supplied to the adjacent space that originated as outside air may be transferred for replacement air. IMC recognizes the use of transfer air as a replacement (makeup) air source. In large buildings such as malls, supermarkets, and schools, adequate transfer air may be available to meet 100% of hood replacement air requirements. Malls and multiple-use-occupancy buildings may specify a minimum amount of transfer air to be taken from their space to keep cooking odors in the kitchen, or they may specify the maximum transfer air available to hold down the cost of conditioning outside air. Code restrictions may prevent the use of corridors as spaces through which transfer air may be routed. Conditions of transfer air are determined by conditioning requirements of the space into which the air is initially supplied.

Air Distribution

The design of a replacement air distribution system can enhance or degrade hood performance. Systems that use a combination of supply, makeup, and transfer air include various components of distribution. Distribution from each source into the vicinity of the hood, must be designed to eliminate high velocities, eddies, swirls, or stray currents that can interrupt the natural rising of the thermal plume from cooking equipment into the hood, thus degrading the performance of the hood. Methods of distribution may include conventional diffusers, compensating hood designs, transfer devices, and simple openings in partitions separating building spaces. Regardless of the method selected, it is important to always deliver replacement air to the hood (1) at proper velocity and (2) uniformly from all directions to which the hood is open. This will minimize excessive cross-currents that could cause spillage. Proper location and/or control of HVAC return grilles is therefore critical. The higher air velocities typically recommended for general ventilation or spot cooling with unconditioned air (75 to 200 fpm at worker) should be avoided around the hood. Hood manufacturers offer a variety of compensating hoods, plenums, and diffusers designed to introduce replacement air effectively.

Compensating Hoods. A common way of distributing replacement air is through compensating systems that are integral with the hood. [Figure 11](#) shows four typical compensating hood configurations. Because actual flows and percentages may vary with hood design, the manufacturer should be consulted about specific applications. The following are typical descriptions.

Air Curtain. This method is typically used for spot-cooling the cooking staff to counter the severe radiant heat generated from equipment such as charbroilers. The air must be heated and/or cooled, depending on local climate. Air curtain discharge can be along the length of the hood front only or along all open sides of the hood. When discharge velocity is too low, air tends to enter the hood directly and may have little effect on hood performance. When discharge velocity is too high, air entrains the cooking plume and spills it into the room. Ideal velocity and throw can improve hood performance and redirect the thermal plume toward the filters. Discharge velocities must be carefully selected to avoid discomfort to personnel and cooling of food. The amount of replacement air generally varies from 10 to 50%, though some designs may recommend up to 70%, depending on the cooking equipment involved. Air temperature should be between 50 and 70°F.

Back Wall Discharge. A makeup air plenum is installed between the back of the hood and wall. The full-length plenum typically extends down the wall to approximately 6 in. below the cooking surface or 2 to 3 ft above the floor. The plenum is typically 6 in. front to back. Makeup air is discharged behind and below the cooking equipment. The bottom of the plenum is provided with diffusers and may also include a balancing damper. The plenum may include an additional discharge slot that directs air up into the hood. As with front-face discharge, air volume and discharge velocity dictate how far into the space the replacement air will travel. The amount of travel and local climate dictate the amount of heating and/or cooling needed. Some code jurisdictions will allow small amounts (typically less than 50%) of replacement air, discharged using this configuration, to be unconditioned. Support for wall shelves, salamander broilers, or cheesemelters mounted under the hood must be considered. The plenum structure typically does not provide sufficient support for mounting these items. In some designs, the rear plenum is ducted vertically to the floor. The air is then discharged at the rear or brought forward and discharged in front of the appliances. Velocity should be minimized.

Front-Face Discharge. Typical replacement air volume is 40 to 80% of exhaust. Air temperature should range from 50 to 70°F, depending on design and kitchen heat load. Depending on design and air volume, discharge velocity may cause replacement air to

travel a considerable distance from the hood. The farther the air travels into the room, the greater the impact on space conditioning; replacement air temperature and degree of conditioning should be selected accordingly. The closer the air outlet's lower edge is to the bottom of the hood, the lower the face velocity must be to avoid drawing effluent out of the hood. Face velocities should be less than 150 fpm to avoid makeup air affecting hood performance.

Internal Discharge. Commonly known as short-circuit, this method introduces replacement air directly into the exhaust hood cavity. This design has limited application, and the amount of air that can be introduced varies considerably with the type of cooking equipment and exhaust flow rate. As noted previously, thermal currents from cooking equipment create a plume of a certain volume that the hood must remove. The hood must therefore draw at least this volume of air from the kitchen, in addition to any internal makeup. If the net exhaust flow rate (total exhaust less internal replacement air) is less than the plume volume, part of the plume may spill out of the hood. Internal replacement air is typically not conditioned; however, depending on local climate, manufacturer's design, type of cooking equipment, and local codes, conditioning may be required. Some local authorities approve internal discharge hoods, and some do not. For unlisted hoods, IMC requires the net quantity of exhaust air to be calculated by subtracting any airflow supplied directly to a hood cavity from the total exhaust flow rate of a hood. Listed hoods are operated in accordance with the terms of the listing. All applicable codes must be consulted to ensure proper criteria are followed.

Perimeter Discharge. This type typically includes a plenum mounted at the ceiling or the top front edge of the hood. Air is discharged across the full length of the hood front in a downward laminar flow. Depending on plenum size and diffuser design, the flow may or may not actually be laminar. Vertical down discharge at low velocities has minimal impact on space conditions and operator. Velocities at the diffuser face in excess of 300 fpm should be avoided. In most climates, makeup air should be heated to 50 to 70°F. Cooling is typically not required except in extreme climates. The manufacturer should be consulted for pressure drops and maximum air volume.

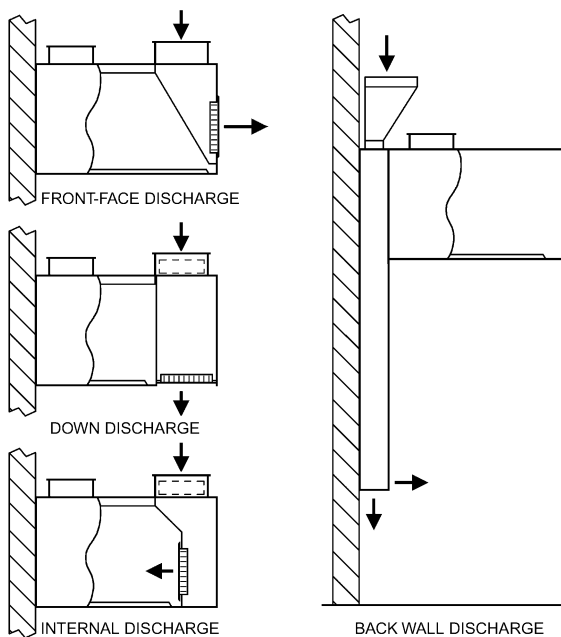

Fig. 11 Internal Methods of Introducing Replacement Air

Multiple Discharge. This method may combine internal, perimeter, air curtain, and/or front face. Each may be served by a separate or common plenum. Balancing dampers may be provided for one or both discharge arrangements. These dampers may be used to fine-tune the amount of air discharged through the air curtain or front face. The air may be heated and/or cooled, depending on local climate and on whether separate or common plenums are used.

Traditional Registers. There are various ways to distribute replacement air in the vicinity of the hood to avoid cross-currents that degrade hood performance. Terminal velocities at the leading edge of the hood should be kept to a minimum of 50 fpm. Nonaspirating diffusers are recommended, especially adjacent to the hood. Typical devices include the following (for more information on diffusers, see [Chapter 32 of the ASHRAE Handbook—Fundamentals](#) and [Chapter 17 of the ASHRAE Handbook—HVAC Systems and Equipment](#)).

Louvered Ceiling Diffusers. Air from these aspirating, two-, three-, or four-way diffusers should not be directed toward exhaust hoods, where it might disturb the thermal plume and adversely affect hood performance. The diffuser should be located so that the jet velocity at the lip of the hood does not exceed 50 fpm. [Figure 12](#) shows a conventional photograph and schlieren optical photographs of the effect of a four-way diffuser on hood capture. Air directed by the diffuser toward the hood sweeps past the front edge of the hood and entrains the thermal plume, causing spillage. Four-way diffusers are typically not acceptable within 15 ft of a canopy hood.

Perforated Diffusers. These nonaspirating, perforated-face diffusers may have internal deflecting louvers, but should not be capable of directing the airflow toward the hood. The diffuser should be located so that the jet velocity at the lip of the hood does not exceed 50 fpm. In some code jurisdictions, when conventional ceiling diffusers are used, only perforated diffusers are allowed in commercial kitchens.

Slot Diffusers. Because the slot opening of these devices is generally small compared to air volume, air velocity is often higher than that which would be obtained with two-, three-, and four-way diffusers. Also, because airflow is mostly downward, the potential for negatively affecting hood performance is quite high if outlets are near the hood. If used with relatively high ceilings, the potential for negative impact is less because the velocity diminishes as air diffuses downward. Slot diffusers are usually nonaspirating.

Displacement Diffusers. These devices, designed to provide low-velocity laminar flow over the diffuser surface, can be placed inside a wall, at the floor, or near floor level on a wall. These diffusers typically supply air from 50 to 70°F in a kitchen, depending on equipment loads, and the hotter, stratified air is removed from the ceiling through exhaust ducts or returned to the HVAC system to be recooled. In contrast with ceiling diffusers, with displacement diffusers, stratification is a desired design component. Adequate wall space (for diffuser placement) and ceiling height (to allow an effective separate stratification zone) are required.

SYSTEM INTEGRATION AND BALANCING

System integration and balancing bring the many ventilation components together to provide the most comfortable, efficient, and economical performance of each component and of the entire system. In commercial kitchen ventilation, the supply air system (typically referred to as the HVAC system) must integrate and balance with the exhaust system. Optimal performance is achieved more by effective use of components through controls and airflow adjustments than by selection or design of the system and components. The following fundamentals for restaurants, and kitchens in particular, should be considered and applied within the constraints of the particular location and its equipment and systems.

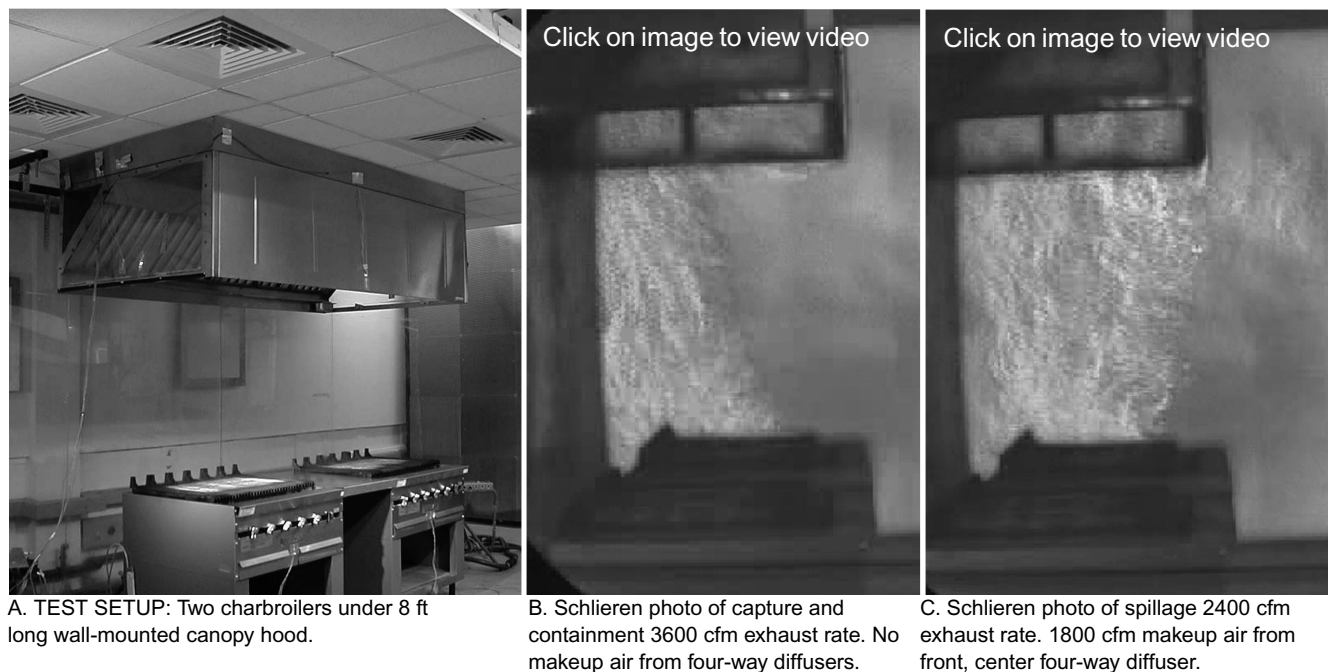

Fig. 12 Effect of Four-Way Diffuser on Hood Capture

Principles

Although there are exceptions, the following are the fundamental principles of integrating and balancing restaurant systems for both comfort control and economical operation:

- In a freestanding restaurant, the overall building should always be slightly positively pressurized compared to the outside to minimize infiltration of untempered air, as well as dirt, dust, and insects, when doors are opened. In multiple-occupancy buildings, a slight negative pressure in the restaurant is desirable to minimize odor migration from the restaurant to other occupancies.
- Every kitchen should always be slightly negative compared to the rooms or areas immediately surrounding it, to (1) better contain unavoidable grease vapors in the kitchen area and limit the extent of cleanup necessary, (2) keep cooking odors in the kitchen area, and (3) prevent the generally hotter and more humid kitchen air from diminishing the comfort level of adjacent spaces, especially dining areas.
- Cross-zoning of airflow should be minimal, especially in temperate seasons, when adjacent zones may be in different modes (e.g., economizer versus air conditioning or heating). Three situations to consider are the following:
 - In transitions from winter to spring and from summer to fall, the kitchen zone could be in economizer, or even mechanical cooling mode, while dining areas are in heating mode. Bringing heated dining-area supply air into a kitchen that is in cooling mode only adds to the cooling load. In some areas, this situation is present every day.
 - When all zones are in the same mode, it is more acceptable, and even more economical, to bring dining-area air into the kitchen. However, the controls to automatically effect this method of operation are more complex and costly.
 - If dedicated kitchen makeup air is heated, thermostatic control of the heating source should ideally be based on kitchen temperature rather than outside temperature. Otherwise, with usual kitchen heat gains and subsequent low balance points for

heating and cooling, it is possible that makeup air heating and kitchen mechanical cooling might be operated simultaneously.

- Typically, no drafts should be noticeable, and temperatures should vary no more than 1°F in dining areas and 3°F in kitchen areas. These conditions can be achieved with even distribution and thorough circulation of air in each zone by an adequate number of registers sized to preclude high air velocities. If there are noticeable drafts or temperature differences, customers and restaurant personnel will be distracted and will not enjoy dining or working.

Both design concepts and operating principles for proper integration and balance are involved in achieving desired results under varying conditions. The same principles are important in almost every aspect of restaurant ventilation.

In designing restaurant ventilation, all exhaust is assumed to be in operation at one time, and the design replacement air quantity is a maximum requirement because the heating and cooling equipment are sized for maximum design conditions.

In restaurants with a single large exhaust hood, balancing should be set for this one operation only. In restaurants with multiple exhaust hoods, some may be operated only during heavy business hours or for special menu items. In this case, replacement air must be controlled to maintain minimum building positive pressure and to maintain the kitchen at a negative pressure under all operating conditions. The more variable the exhaust, or the more numerous and smaller the zones involved, the more complex the design, but the overall pressure relationship principles must be maintained to provide optimum comfort, efficiency, and economy.

A different application is a kitchen with one side exposed to a larger building with common or remote dining. Examples are a food court in a mall or a small restaurant in a hospital, airport, or similar building. Positive pressure at the front of the kitchen might cause some cooking grease, vapor, and odors to spread into the common building space, which would be undesirable. In such a case, the kitchen area is held at a negative pressure relative to other common building areas as well as to its own back room storage or office space.

Air Balancing

Balancing is best performed when the manufacturers of all the equipment can provide a certified reference method of measuring the airflows, rather than depending on generic measurements of duct flows or other forms of measurement in the field, which can be in error by 20% or more. The equipment manufacturer should be able to develop a reference method of measuring airflow in a portion of the equipment that is dynamically stable in the laboratory as well as in the field. This method should relate directly to airflow by graph or formula.

The general steps for air balancing in restaurants are as follows:

1. Exhaust hoods should be set to their proper flow rates, with supply and exhaust fans on.
2. Next, supply airflow rate, whether part of combined HVAC units or separate replacement air units, should be set to design values through the coils and the design supply flows from each outlet, with approximately correct settings on the outside airflow rate. Then, correct outside and return airflow rates should be set proportionately for each unit, as applicable. These settings should be made with exhaust on, to ensure adequate relief for the outside air.

Where outside air and return air flows of a particular unit are expected to modulate, there should ideally be similar static losses through both airflow paths to preclude large changes in total supply air from the unit. Such changes, if large enough, could affect the efficiency of heat exchange and could also change airflows within and between zones, thereby upsetting air distribution and balance.

3. Next, outside air should be set with all fans (exhaust and supply) operating. Pressure difference between inside and outside should be checked to see that (1) nonkitchen zones of the building are at a positive pressure compared to outside and (2) kitchen zone pressure is negative compared to the surrounding zones and negative or neutral compared to outside.

For applications with modulating exhaust, every step of exhaust and replacement should be shut off, one step at a time. Each combination of operation should be rechecked to ensure that design pressures and flows are maintained in each zone and between zones. This requires that the replacement airflow rate compensate automatically with each increment of exhaust. It may require some adjustments in controls or in damper linkage settings to get the correct proportional response.

4. When the preceding steps are complete, the system is properly integrated and balanced. At this time, all fan speeds and damper settings (at all modes of operation) should be permanently marked on the equipment and in the test and balance report. Air balance records of exhaust, supply, return, fresh air, and individual register airflows must also be completed. These records should be kept by the food service facility for future reference.
5. For new facilities, after two or three days in operation (no longer than a week and usually before the facility opens), all belts in the system should be checked and readjusted because new belts wear in quickly and could begin slipping.
6. Once the facility is operational, the performance of the ventilation system should be checked to verify that the design is adequate for actual operation, particularly at maximum cooking and at outside environmental extremes. Any necessary changes should be made, and all the records should be updated to show the changes.

Rechecking the air balance should not be necessary more than once every 2 years unless basic changes are made in facility operation. If there are any changes, such as adding a new type of cooking equipment or deleting exhaust connections, the system should be modified accordingly.

Multiple-Hood Systems

Kitchen exhaust systems serving more than a single hood present several design challenges not encountered with single-hood systems. One of the main challenges of multiple-hood exhaust systems is air balancing. Because balancing dampers are not permitted in the exhaust ducts, the system must be balanced by design. Zoning may be desirable for a balanced design and to improve energy conservation. Hood accessories are now available to allow balancing at individual hoods. Additionally, most filters come in varying sizes to allow pressure loss equalization at varying airflows. Some hoods and grease filters have adjustable baffles that allow airflow to be adjusted at the hood. These may be helpful for relatively fine balancing, but the system must provide most of the balancing. System zoning is preferred, because incorrect installation of a multibranch system can lead to complex problems. Adjustable filters should not be used when they can be interchanged between hoods or within the same hood because an interchange could disrupt the previously achieved balance. Balancing can also be accomplished by changing the number and/or size of filters.

For correct flow through a branch duct in a multiple-hood system, the static pressure loss of the branch must match the static pressure loss of the common duct upstream from the point of connection. Any exhaust points subsequently added or removed must be designed to comply with the minimum velocities required by code and to maintain the balance of the remaining system. In cases such as master kitchen-exhaust systems, which are sometimes used in shopping center food courts, no single group is responsible for the entire design. The base building designer typically lays out ductwork to (or through) each tenant space, and each tenant selects a hood and lays out connecting ductwork. Often the base building designer has incomplete information on tenant exhaust requirements. Therefore, one engineer must be responsible for defining criteria for each tenant's design and for evaluating proposed tenant work to ensure that tenant designs match the system's capacity. The engineer should also evaluate any proposed changes to the system, such as changing tenancy. Rudimentary computer modeling of the exhaust system may be helpful (Elovitz 1992). Given the unpredictability and volatility of tenant requirements, it may not be possible to balance the entire system perfectly. However, without adequate supervision, the probability that at least part of the system will be badly out of balance is very high.

For greatest success with multiple-hood exhaust systems, minimize pressure losses in the ducts by keeping velocities low, minimizing sharp transitions, and using hoods with relatively high pressure drops. When pressure loss in the ducts is low compared to the loss through the hood, changes in pressure loss in the ductwork because of field conditions or changes in design airflow will have a smaller effect on total pressure loss and thus on actual airflow.

Minimum code-required air velocity must be maintained in all parts of the exhaust ductwork at all times. If fewer or smaller hoods are installed than the design anticipated, resulting in low velocity in portions of the ductwork, the velocity must be brought up to the minimum. One way is to introduce replacement air, preferably untempered, directly into the exhaust duct where it is required (see [Figure 13](#)). The bypass duct should connect to the top or sides (at least 2 in. from the bottom) of the exhaust duct to prevent backflow of water or grease through the bypass duct when fans are off. This arrangement is shown in NFPA *Standard 96* and should be discussed with the authority having jurisdiction.

A fire damper should be provided in the bypass duct, located close to the exhaust duct. Bypass duct construction should be the same as the exhaust duct construction, including enclosure and clearance requirements, for at least several feet beyond the fire damper. Means to adjust the bypass airflow must be provided upstream of the fire damper. All dampers must be in the clean bypass air duct so they are not exposed to grease-laden exhaust air. The difference in pressure between replacement and exhaust air

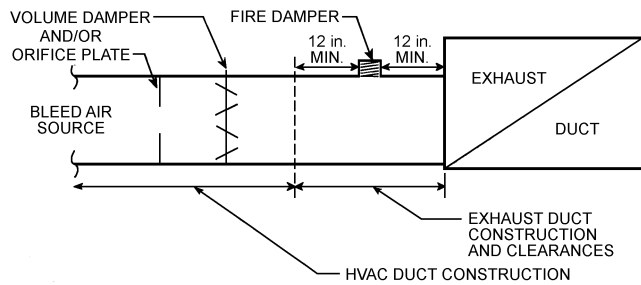

Fig. 13 Method of Introducing Replacement Air Directly into Exhaust Duct

duct may be great; the balancing device must be able to make a fine airflow adjustment against this pressure difference. It is best to provide two balancing devices in series, such as an orifice plate or blast gate for coarse adjustment followed by an opposed-blade damper for fine adjustment.

Directly measuring air velocities in the exhaust ductwork to assess exhaust system performance may be desirable. Velocity (pitot-tube) traverses may be performed in kitchen exhaust systems, but holes drilled for the pitot tube must be liquidtight to maintain the fire-safe integrity of the ductwork per NFPA *Standard* 96. Holes should never be drilled in the bottom of a duct, where they may collect grease. Velocity traverses should not be performed when cooking is in progress because grease collects on the instrumentation.

Dynamic Volumetric Flow Rate Effects

Design exhaust flow rates for kitchen hoods are determined either by laboratory tests or by building code requirements. In both cases the intent is to ensure capture and containment under maximum cooking load conditions. The majority of kitchen exhaust systems use fixed-speed fans. Because a fan is a constant-volumetric mover, at any given speed it will always move the same volume of air, regardless of the density of the air because of temperature, humidity, and other gases. Thus, for a given motor speed, a kitchen exhaust fan will always move the same volume of air whether during maximum cooking, minimum cooking, with hot appliances at idle, or even with cold appliances. Although the air volume removed by the exhaust fan is constant, the amount of air removed from the kitchen space varies according to cooking appliance operating conditions:

- During full-load cooking, the exhaust system pulls the least amount of air from the kitchen, and requires the least amount of replacement air to keep a balanced system. Air entering the fan inlet consists of the air expanded by the hot cooking surface, effluent generated by the cooked food, entrained kitchen air to ensure capture and containment at the perimeter of the hood, and flue gases when gas-fired equipment is used. This is usually the lightest-density, highest-temperature air removed by the fan.
- During ready-to-cook (idle) conditions (appliances at operating temperature, but no cooking effluent being produced), the air being exhausted is a combination of kitchen air (expanded by the hot cooking surface) and entrained kitchen air. Compared to most full-load cooking conditions, the required replacement air volume from the kitchen increases to fulfill the exhaust fan requirement and to keep a balanced system. Air entering the fan inlet is denser than under cooking conditions because the increased volume of kitchen air has a lower temperature than cooking effluent does.
- During cold conditions, air entering the fan inlet is at or near kitchen temperature and humidity conditions. This is the condition with the greatest amount of air leaving the kitchen and requires the greatest amount of replacement air to keep a balanced system. This is the heaviest-density air of the three appliance

operating conditions. In a kitchen, this condition usually occurs for a short while when the exhaust system is first started and before the cooking appliances are heated up; it can also occur when the exhaust system is operated to check equipment performance, to assess the air balance and distribution, or to just provide ventilation during a cleaning or renovation project.

Changes in the amount of air volume removed from the kitchen based on appliance operations have implications for (1) setting hood exhaust fan speed in the field, (2) determining the amount of replacement air or transfer air for the kitchen space, and (3) air-conditioning and heating loads attributed to makeup air or transfer air.

Appliance temperatures, food and flue products, and exhaust flow rates determine the volume created by the cooking process. The resulting air temperatures vary widely because of overexhausting, close-coupling, hood style, etc. Duct temperatures range from slightly above ambient for large, overexhausted systems to over 200°F for close-coupled minimum-flow systems. The result is a difference in exhaust and replacement air requirements. For instance, two griddles under a backshelf hood could show a 50 cfm difference between exhaust and replacement air, a two-deck oven could show a 200 cfm difference, and two chain charbroilers could show a 500 cfm difference.

The best practice for determining building air balance is to use hot/no cooking (idle) condition flow rates. Most restaurants spend about 70% of their time in this condition. If air balance is determined under cold conditions, the makeup or transfer air will be greater than required during hot/ready-to-cook and cooking operations. The result will be a slightly higher pressure than required in the kitchen and may result in air transfer to other parts of the building.

Similarly, the best practice for determining heating and air-conditioning loads from makeup or transfer air is to use hot/no cooking condition flow rates. Using cold/no-cooking conditions will result in a larger design load estimate than required.

ENERGY CONSIDERATIONS

Energy conservation in restaurants depends on the following variables:

Climate. Outside temperature and humidity are key determinants of restaurant HVAC energy use. Because climatic zones vary dramatically in temperature and humidity, kitchen ventilation conservation designs have widely varying economic recovery periods. In new facilities, the designer can select conservation measures suitable for the climatic zone and the HVAC system to maximize the economic benefits.

Restaurant Type. Claar et al. (1985) defined five restaurant types: fast-food, full-service, coffee shop, pizza, and cafeteria. Restaurant associations identify many additional restaurant types, among which energy use varies significantly. As a result, some energy conservation measures work in all restaurants, whereas others may work only in specific types. For simplicity, this discussion classifies restaurants as cafeteria, fast-food, full-menu, and pizza.

Hood Type and Equipment Characteristics. The type of exhaust hood selected depends on such factors as restaurant type, restaurant menu, and food service equipment. Exhaust flow rates are largely determined by the food service equipment and hood style. The effectiveness of conservation measures, whether in a new design or as a retrofit, is also affected by the type of hood and food service equipment.

Energy Conservation Measures

Energy costs in restaurants vary from 2 to 6% of gross sales. The following major energy conservation measures can reduce commercial kitchen ventilation costs.

Custom-Designed Hoods. A typical cooking lineup combines food service equipment with different thermal updraft characteris-

tics and exhaust flow rates depending on cooking load, cooking temperature, product cooked, fuel source, and so forth. Exhaust hoods are sized to handle the worst-case cooking appliance; during idle or off-peak periods, exhaust quantities may be excessive.

Custom-designed hoods for each piece of equipment can reduce exhaust/replacement air quantities and consequently reduce fan sizes, energy use, and energy costs for all types of restaurants. Hood manufacturers recommend exhaust flow rates based on either thermal current charts or empirical tests. To operate at flow rates lower than required by code, custom-designed hoods must be either listed or approved by the local code official.

Dining-Room Air for Kitchen Ventilation. Most fast-food and pizza restaurants do not physically segregate the kitchen from the dining room, so conditioned air moves from the dining area to the kitchen. Dining-room air cools the kitchen and provides replacement air for the kitchen exhaust.

Sometimes full-menu and cafeteria facilities are designed so that minimal replacement air transfers between the dining room and the kitchen; therefore, the majority of the replacement air must be made up by a kitchen makeup air unit.

In restaurants where the kitchen and dining room are physically segregated, ducts between the two areas permit conditioned replacement air to flow to the kitchen. This design can reduce kitchen replacement air requirements and enhance employee comfort, especially if the kitchen is not air conditioned. Of course, the dining room must have replacement air to replace the air transferred to the kitchen. Also, care must be taken to ensure that enough replacement air is introduced into the kitchen to meet the requirements of applicable codes and standards.

Heat Recovery from Exhaust Hood Ventilation Air. High-temperature effluent, often in excess of 400°F, heats the replacement air to 100 to 200°F as it travels over the cooking surfaces and areas. It is frequently assumed that this heated exhaust air is suitable for heat recovery; however, smoke and grease in the exhaust air will, with time, cover any heat transfer surface. Under these conditions, the heat exchangers require constant maintenance (e.g., automatic washdown) to maintain acceptable heat recovery.

Because heat recovery systems are very expensive, only food service facilities with large amounts of cooking equipment and large cooking loads are good candidates for this equipment. Heat recovery may work in full-menu and cafeteria restaurants and in institutional food service facilities such as prisons and colleges. An exhaust hood equipped with heat recovery is more likely to be cost-effective where the climate is extreme. A mild climate, such as in California, is not conducive to use of this conservation measure. The principal obstacle to heat recovery from kitchen exhaust systems is that heat removal from the exhaust aids condensation of grease vapors on recovery system surfaces in the exhaust stream, resulting in lower heat transfer efficiency and higher maintenance requirements. An additional obstacle is providing enough heat transfer surface area cost-effectively.

Extended Economizer Operation. In most restaurants, mechanical cooling is required to keep the staff and customers cool. By operating in economizer mode, similar cooling can be achieved at less cost because only fans are operated and not compressors. Economizers can be used in lieu of or with mechanical cooling when the outside dry-bulb temperature (and sometimes humidity) is $\pm 10^\circ\text{F}$ lower than the return air condition. Economizer systems may be designed to increase ventilation by 25% or more over normal ventilation, or about 50 to 60% of system supply capacity. For additional savings, economizers can increase outside air to 100%, usually with fan-powered relief. See the on section Replacement Air Sources for design considerations for kitchen applications.

Analysis of energy-use data from monitoring food service facilities indicates that heating/cooling balance points for commercial kitchens may be significantly lower than the typical 65°F of other commercial buildings. One project that monitored seven diverse

restaurants for an extended period (Claar et al. 1985) revealed an average balance point for the group of 53.3°F. Accordingly, though the temperature band for economizer operations in common commercial buildings might be limited to 60 to 75°F, kitchens may benefit from an economizer range starting in the lower 50s, providing for much greater economic application and financial acceptance.

Optimized Heating and Cooling Set Points. IMC requires that makeup air be conditioned to within 10°F of the kitchen space, except when the makeup air is part of the air-conditioning system and does not adversely affect comfort conditions in the occupied space. The exception is important because it allows the design to be optimized to take advantage of the typically lower heating/cooling balance points of commercial kitchens. Accordingly, it is essential that the heating set point of dedicated makeup units not be set higher than the forecasted heating/cooling balance point to avoid simultaneous operation of makeup heating and HVAC cooling. Designers should set the makeup unit heating exit temperature lower than the lowest temperature at which cooling will be activated.

Reduced Exhaust and Replacement (Makeup) Airflow Rates. Tempering outside replacement air can account for a large part of a food service facility's heating and cooling costs. By reducing exhaust flow rates (and the corresponding replacement air quantity) when no product is being cooked, energy cost can be significantly reduced. Field evaluations by one large restaurant chain suggest that cooking appliances may be at zero load for 75% or more of an average business day (Spata and Turgeon 1995). During these periods when no smoke or grease-laden vapors are being produced, NFPA *Standard 96* allows reduction of exhaust quantities. The only restriction on the reduced exhaust quantity is that it be "sufficient to capture and remove flue gases and residual vapors."

FIRE PROTECTION

The combination of flammable grease and particulates carried by kitchen ventilation systems and the potential of cooking equipment to be an ignition source creates a higher hazard level than normally found in HVAC systems. Design of an exhaust system serving cooking equipment that may produce grease-laden vapors must provide, at a minimum, a reasonable level of protection for the safety of building occupants and fire fighters. The design can be enhanced to provide extra protection for property.

Replacement air systems, air-conditioning systems serving a kitchen, and exhaust systems serving only cooking equipment that does not produce grease-laden vapor have no specific fire protection requirements beyond those applicable to similar systems not located in kitchens. However, an exhaust system serving any grease-producing cooking equipment must be considered a grease exhaust system even if it also serves non-grease-producing equipment.

Fire protection starts with proper operation and maintenance of the cooking equipment and the exhaust system. After that, the two primary aspects of fire protection in a grease exhaust system are (1) to extinguish a fire quickly once it has started and (2) to prevent the spread of fire from or to the grease exhaust system.

Fire Suppression

NFPA *Standard 96* requires that exhaust systems serving grease-producing equipment must include a fire-extinguishing system, except where certain listed grease-removal devices or systems are installed. The fire-extinguishing system must protect cooking surfaces, hood interior, hood filters or grease extractors, ducts, and any other grease-removal devices in the system. The most common fire-extinguishing systems are wet chemical and water spray systems.

Operation. Actuation of any fire-extinguishing system should not depend on normal building electricity. If actuation relies on electricity, it should be supplied with standby power.

Any extinguishing system must automatically shut off all supplies of fuel and heat to all equipment protected by that system. Any

gas appliance not requiring protection but located under the same ventilating equipment must also be shut off. On operation of a wet chemical or water fire-extinguishing system, all electrical sources located under the ventilating equipment, if subject to exposure to discharge from the fire-extinguishing system, must be shut off. If the hood is in a building with a fire alarm system, actuation of the hood extinguishing system should send a signal to the fire alarm.

Dry and Wet Chemical Systems. Wet chemical fire-extinguishing systems are the most common in new construction for protecting hoods and exhaust systems. Dry chemical systems were popular; however, most manufacturers have removed them from the market because they have not passed UL *Standard 300*. Dry chemical systems are covered in NFPA *Standard 17*, and wet chemical systems are covered in NFPA *Standard 17A*. Both standards provide detailed application information. Systems are tested for their ability to extinguish fires in cooking operations in accordance with UL *Standard 300*. To date, only wet chemical systems are listed to UL *Standard 300*.

Both dry and wet chemicals extinguish a fire by reacting with fats and grease to **saponify**, or form a soapy foam layer that prevents oxygen from reaching the hot surface. This suppresses the fire and prevents reignition. Saponification is particularly important with deep fat fryers, where the frying medium may be hotter than its autoignition temperature for some time after the fire is extinguished. If the foam layer disappears or is disturbed before the frying medium has cooled below its autoignition temperature, it can reignite.

Frying media commonly used today have autoignition points of about 685 to 710°F when new. Contamination through normal use lowers the autoignition point. The chemical agent that extinguishes the fire also contaminates the frying medium, which can further reduce the autoignition point by 50 to 60°F. One advantage of wet chemical systems over dry chemical systems is that the wet chemical provides extra cooling to the frying medium, so that it falls below the autoignition point more quickly.

For a chemical system protecting the entire exhaust system, fire-extinguishing nozzles are located over the cooking equipment being protected, in the hood to protect grease-removal devices and the hood plenum, and at the duct collar (downstream from any fire dampers) to protect ductwork. The duct nozzle is rated to protect an unlimited length of ductwork, so additional nozzles are not required further downstream in the ductwork. Fire detection is required at the entrance to each duct (or ducts, in hoods with multiple duct takeoffs) and over each piece of cooking equipment that requires protection. The detector at the duct entrance may also cover the piece of cooking equipment directly below it.

Chemical fire-extinguishing systems are available as listed, pre-engineered (packaged) systems. Chemical systems typically consist of one or more tanks of chemical agent (dry or wet), a propellant gas, piping to the suppression nozzles, fire detectors, and auxiliary equipment. The fire detectors are typically fusible links that melt at a set temperature associated with a fire, although electronic devices are also available. Auxiliary equipment may include manual pull stations, gas shutoff valves (spring-loaded or solenoid-actuated), and auxiliary electric contacts.

Actuation of dry and wet chemical suppression systems is typically completely mechanical, requiring no electric power. Fire detectors are typically interconnected with the system actuator by steel cable in tension, so that melting of any fusible links releases the tension on the steel cable, causing the actuator to release the propellant and suppressant. The total length of the steel cable and the number of pulley elbows permitted are limited. A manual pull station is typically connected to the system actuator by steel cable. If a mechanical gas valve is used, it is also connected to the system actuator by steel cable. System actuation also switches auxiliary dry electrical contacts, which can be used to shut off electrical cooking equipment, operate an electric gas valve, shut off a replacement air fan, and/or send an alarm signal to the building fire alarm system.

Manual pull stations are generally required to be at least 10 ft from the cooking appliance and in a path of egress. Some authorities may prefer that the pull station be installed closer to the cooking equipment, for faster response; however, if it is too close, it may not be possible to approach it once a fire has started. Refer to the applicable code requirements for each jurisdiction to determine specific requirements for location and mounting heights of pull stations.

Water Systems. Water can be used for protecting cooking appliances, hoods, and grease exhaust systems. Standard fire sprinklers may be used throughout the system, except over deep-fat fryers, where special automatic spray nozzles specifically listed for the application must be used. These nozzles must be aimed properly and supplied with the correct water pressure. Many hood manufacturers market a pre-engineered water spray system that typically includes a cabinet containing the necessary plumbing and electrical components to monitor the system and initiate fuel shutoff and building alarms. A water system for cleaning or grease removal in a hood can also protect the hood or duct in the case of fire, if the system is listed for this purpose.

Application of standard fire sprinklers for protection of cooking appliances, hoods, and grease exhaust systems is covered by NFPA *Standard 13*. NFPA *Standard 96* covers maintenance of sprinkler systems serving an exhaust system. The sprinklers must connect to a wet-pipe building sprinkler system installed in compliance with NFPA *Standard 13*.

Water systems that spray a fine mist can be used to protect cooking equipment. The water spray suppresses the fire in two ways: the mist spray absorbs heat from the fire, and then becomes steam, which displaces air and suffocates the fire.

Although standard sprinklers may be used to protect cooking equipment other than deep-fat fryers, care must be taken to ensure that sprinklers are properly selected for a fine mist discharge; if pressure is too high or the spray too narrow, the water spray could push flames off the cooking equipment. Most hood manufacturers that use water to protect cooking equipment use sprinklers listed for deep-fryers over all the cooking equipment.

One advantage of a sprinkler system is that it has virtually unlimited capacity, whereas chemical systems have limited chemical supplies. This can be an advantage in suppressing a serious fire, but all the water must be safely removed from the space. Where sprinklers are used in ducts, the ductwork should be pitched to drain safely. NFPA *Standard 13* requires that sprinklers used to protect ducts be installed every 10 ft on center in horizontal ducts, at the top of every vertical riser, and in the middle of any vertical offset. Any sprinklers exposed to freezing temperatures must be protected.

Hoods that use water either for periodic cleaning (water-wash) or for grease removal (cold water mist) can use this feature as a fire-extinguishing system to protect the hood, grease-removal device, and/or ducts in the event of a fire, if the system has been tested and listed for the purpose. The water supply for these systems may be from the kitchen water supply if flow and pressure requirements are met. These hoods can also act as a fire stop because of their multi-pass configuration and the fact that the grease extractors are not removable.

Combination Systems. Different system types may protect different parts of the grease exhaust system, as long as the entire system is protected. Examples include (1) an approved water-wash or water mist system to protect the hood in combination with a dry or wet chemical system to protect ducts and the cooking surface or (2) a chemical system in the hood backed up by water sprinklers in the ductwork. Combination systems are more common in multiple-hood systems, where a separate extinguishing system may be used to protect a common duct. If combination systems will discharge their suppressing agents together in the same place, the agents must be compatible.

Multiple-Hood Systems. All hoods connected to a multiple-hood exhaust system must be on the same floor of the building to prevent the spread of fire through the duct from floor to floor. Preferably, there should be no walls requiring greater than a 1 h fire resistance rating between hoods.

The multiple-hood exhaust system must be designed to (1) prevent a fire in one hood or in the duct from spreading through the ducts to another hood and (2) protect against a fire starting in the common ductwork. Of course, the first line of protection for the ducts is keeping it clean. Especially in a multiple-tenant system, a single entity must assume responsibility for cleaning the common ductwork frequently.

Each hood must have its own fire-extinguishing system to protect the hood and cooking surface. A single system could serve more than one hood, but in the event of fire under one hood, the system would discharge its suppressant under all hoods served, resulting in unnecessary cleanup expense and inconvenience. A water-mist system could serve multiple hoods if sprinkler heads were allowed to operate independently.

Because of the possibility of a fire spreading through ducts from one hood to another, the common ductwork must have its own fire protection system. The appendices of *NFPA Standards 17* and *17A* present detailed examples of how common ducts can be protected either by one system or by a combination of separate systems serving individual hoods. Different types of fire-extinguishing systems may be used to protect different portions of the exhaust system; however, in any case where two different types of system can discharge into the common duct at the same time, the agents must be compatible.

As always, actuation of the fire-extinguishing system protecting any hood must shut off fuel or power to all cooking equipment under that hood. When a common duct, or portion thereof, is protected by a chemical fire-extinguishing system that activates from a fire in a single hood, *NFPA Standards 17* and *17A* require shutoff of fuel or power to the cooking equipment under every hood served by that common duct, or portion of it protected by the activated system, even if there was no fire in the other hoods served by that duct.

From an operational standpoint, it is usually most sensible to provide one or more fire-extinguishing systems to detect and protect against fire in common ducts and a separate system to protect each hood and its connecting ducts. This (1) prevents a fire in the common duct from causing discharge of fire suppressant under an unaffected hood and (2) allows unaffected hoods to continue operation in the event of a fire under one hood unless the fire spreads to the common duct.

Preventing Fire Spread

The exhaust system must be designed and installed both to prevent a fire starting in the grease exhaust system from damaging the building or spreading to other building areas and to prevent a fire in one building area from spreading to other parts of the building via the grease exhaust system. This protection has two main aspects: (1) maintaining clearance from the duct to other portions of the building and (2) enclosing the duct in a fire-resistance-rated enclosure. Both aspects are sometimes addressed by a single action.

Clearance to Combustibles. A grease exhaust duct fire can generate gas temperatures of 2000°F or greater in the duct. In such a grease fire, heat radiating from the hot duct surface can ignite combustible materials near the duct. Most codes require a minimum clearance of 18 in. from the grease exhaust duct to any combustible material. However, even 18 in. may not be sufficient clearance to prevent ignition of combustibles in the case of a major grease fire, especially in larger ducts.

Several methods to protect combustible materials from the radiant heat of a grease duct fire and permit reduced clearance to combustibles are described in *NFPA Standard 96*. Previous editions required that these protections be applied to the combustible mate-

rial rather than to the duct, on the theory that if the duct is covered with an insulating material, the duct itself will become hotter than it would if it were free to radiate its heat to the surroundings. The hotter temperatures could result in structural damage to the duct. *NFPA Standard 96* now allows materials to be applied to the actual duct. However, because this edition may not have been accepted by some jurisdictions, the authority having jurisdiction should be consulted before clearances to combustible materials are reduced.

Listed grease ducts, typically double-wall ducts with or without insulation between the walls, may be installed with reduced clearance to combustibles in accordance with manufacturers' installation instructions, which should include specific information regarding the listing. Listed grease ducts are tested under *UL Standard 1978*.

NFPA Standard 96 also requires a minimum clearance of 3 in. to "limited combustible" materials (e.g., gypsum wallboard on metal studs). At present, none of the standards and model codes requires any clearance to noncombustible materials except for enclosures.

Enclosures. Normally, when a duct penetrates a fire-resistance-rated wall or floor, a fire damper is used to maintain the integrity of the wall or floor. Because fire dampers may not be installed in a grease exhaust duct unless specifically approved for such use, there must be an alternative means of maintaining the integrity of rated walls or floors. Therefore, grease exhaust ducts that penetrate a fire-resistance-rated wall or floor-ceiling assembly must be continuously enclosed in a fire-rated enclosure from the point the duct penetrates the first fire barrier until the duct leaves the building. Listed grease ducts are also subject to these enclosure requirements. The requirements are similar to those for a vertical shaft (typically 1 h rating if the shaft penetrates fewer than three floors, 2 h rating if it penetrates three or more floors), except that the shaft can be both vertical and horizontal. In essence, the enclosure extends the room containing the hood through all the other compartments of the building without creating any unprotected openings to those compartments.

Where a duct is enclosed in a rated enclosure, whether vertical or horizontal, clearance must be maintained between the duct and the shaft. *NFPA Standard 96* and *IMC* require minimum 6 in. clearance and that the shaft be vented to the outside. *IMC* requires that each exhaust duct have its own dedicated enclosure.

Some available materials are listed to serve as a fire-resistance-rated enclosure for a grease duct when used to cover a duct directly with minimal clear space between the duct and the material. These listed materials must be applied in strict compliance with the manufacturer's installation instructions, which may limit the size of duct to be covered and specify required clearances for duct expansion and other installation details. When a duct is directly covered with an insulating material, there is a greater chance of structural damage to the duct from the heat of a severe fire. The structural integrity of exhaust ducts should be assessed after any serious duct fire.

Insulation materials that have not been specifically tested and approved for use as fire protection for grease exhaust ducts should not be used in lieu of rated enclosures or to reduce clearance to combustibles. Even insulation approved for other fire-protection applications, such as to protect structural steel, may not be appropriate for grease exhaust ducts because of the high temperatures that may be encountered in a grease fire.

Exhaust and Supply Fire-Actuated Dampers. Because of the risk that the damper may become coated with grease and become a source of fuel in a fire, balancing and fire-actuated dampers are not permitted at any point in a grease exhaust system except where specifically listed for each use or required as part of a listed device or system. Typically, fire dampers are found only at the hood collar and only if provided by the manufacturer as part of a listed hood.

Opinions differ regarding whether any fire-actuated dampers should be provided in the exhaust hood. On one hand, a fire-actuated damper at the exhaust collar may prevent a fire under the hood from spreading to the exhaust duct. However, like anything in the exhaust

airstream, the fire-actuated damper and linkage may become coated with grease if not properly maintained, which may impede damper operation. On the other hand, without fire-actuated dampers, the exhaust fan will draw smoke and fire away from the hood. Although this cannot be expected to remove all smoke from the kitchen during of a fire, it can help to contain smoke in the kitchen and minimize migration of smoke to other areas of the building.

A fire-actuated damper will generally close only in the event of a severe fire; most kitchen fires are extinguished before enough heat is released to trigger the fire-actuated damper. Thus the hood fire-actuated damper remains open during relatively small fires, allowing the hood to remove smoke, but can close in the event of a severe fire, helping to contain the fire in the kitchen area.

Fan Operations. If it is over 2000 cfm, the replacement air supply to the kitchen is generally required to be shut down during fire to avoid feeding air to the fire. However, if the exhaust system is intended to operate during a fire to remove smoke from the kitchen (as opposed to just containing it in the kitchen), the replacement air system must operate as well. If the hood has an integral replacement air plenum, a fire-actuated damper must be installed in the replacement air collar to prevent a fire in the hood from entering the replacement air ductwork. NFPA *Standard 96* details the instances where fire-actuated dampers are required in a hood replacement air assembly.

Regardless of whether fire-actuated dampers are installed in the exhaust system, NFPA *Standard 96* calls for the exhaust fan to continue to run in the event of a fire unless fan shutdown is required by a listed component of the ventilating system or of the fire-extinguishing system. Dry and wet chemical fire-extinguishing systems protecting ductwork are tested both with and without airflow; exhaust airflow is not necessary for proper operation.

OPERATION AND MAINTENANCE

Operation

All components of the ventilation system are designed to operate in balance with each other, even under variable loads, to properly capture, contain, and remove cooking effluent and heat and maintain proper space temperature control in the most efficient and economical manner. Deterioration in any of these components unbalances the system, affecting one or more of its design concepts. The system design intent should be fully understood by the operator so that any deviations in operation can be noted and corrected. In addition to creating health and fire hazards, normal cooking effluent deposits can also unbalance the system, so they must be regularly removed.

All components of exhaust and replacement air systems affect proper capture, containment, and removal of cooking effluent. In the exhaust system, this includes the cooking equipment itself, exhaust hood, all filtration devices, ducts, exhaust fan, and any dampers. In the replacement air system, this includes the air-handling unit(s) with intake louvers, dampers, filters, fan wheels, heating and cooling coils, ducts, and supply registers. In systems that obtain their replacement air from the general HVAC system, this also includes return air registers and ducts.

When the system is first set up and balanced in new condition, these components are set to optimum efficiency. In time, all components become dirty; filtration devices, dampers, louvers, heating and cooling coils, and ducts become restricted; fan blades change shape as they accumulate dirt and grease; and fan belts loosen. In addition, dampers can come loose and change position, even closing, and ducts can develop leaks or be blocked if internal insulation sheets fall down.

All these changes deteriorate system performance. The operator should know how the system performed when it was new, to better recognize when it is no longer performing the same way. This knowledge allows problems to be found and corrected sooner and the peak efficiency and safety of system operation to better be maintained.

Maintenance

Maintenance may be classified as preventive or emergency (breakdown). **Preventive maintenance** keeps the system operating as close as possible to optimal performance, including maximum production and least shutdown. It is the most effective maintenance and is preferred.

Preventive maintenance can prevent most emergency shutdowns and emergency maintenance. It has a modest ongoing cost and fewer unexpected costs. Clearly the lowest-cost maintenance in the long run, it keeps the system components in peak condition, extending the operating life of all components.

Emergency maintenance must be applied when a breakdown occurs. Sufficient staffing and money must be applied to the situation to bring the system back on line in the shortest possible time. Such emergencies can be of almost any nature. They are impossible to predict or address in advance, except to presume the type of component failures that could shut the system down and keep spares of these components on hand or readily accessible, so they can be quickly replaced. Preventive maintenance, which includes regular inspection of critical system components, is the most effective way to avoid emergency maintenance.

Following are brief descriptions of typical operations of various components of kitchen ventilation systems and the type of maintenance and cleaning required to bring the abnormally operating system back to normal. Many nontypical operations are not listed here.

Cooking Equipment

Normal Operation. Produces properly cooked product, of correct temperature, within expected time. Minimum smoke during cooking.

Abnormal Operation. Produces undercooked product, of lower temperature, with longer cooking times. Increased smoke during cooking.

Cleaning/Maintenance. Clean solid cooking surfaces between each cycle if possible, or at least once a day. Baked-on product insulates and retards heat transfer. Filter frying medium daily and change it on schedule recommended by supplier. Check that (1) fuel source is at correct rating, (2) thermostats are correctly calibrated, and (3) conditioned air is not blowing on cooking surface.

Solid-fuel appliances are listed above as “Extra-Heavy Duty” (see [Table 2](#)) and require additional attention. A hood over a solid-fuel appliance must be individually vented and therefore not be combined at any point with another duct and fan system. Using a UL *Standard 762* upblast, in-line, or utility set fan listed to 400 or 500°F is suggested because the airstream temperature may be hotter without cooler air combining from other, typically lower-temperature cooking appliances. Design, installation, and maintenance precautions for the use of and emissions from solid fuel include monthly duct cleaning with weekly inspections, spark arrestors, and additional spacing to fryers. Refer to NFPA *Standard 96*, Chapters 5 to 10 and 14, and IMC sections 507 and 906, for additional direction.

Exhaust Systems

Normal Operation. All cooking vapors are readily drawn into the exhaust hood, where they are captured and removed from the space. The environment immediately around the cooking operation is clear and fresh.

Abnormal Operation. Many cooking vapors do not enter the exhaust hood at all, and some that enter subsequently escape. The environment around the cooking operation, and likely in the entire kitchen, is contaminated with cooking vapors.

Cleaning/Maintenance. Clean all grease removal devices in the exhaust system. Hood filters should be cleaned at least daily. For other devices, follow the minimum recommendations of the manufacturer; even these may not be adequate at very high flow rates or with products producing large amounts of effluent. Check that

(1) all dampers are in their original position, (2) fan belts are properly tensioned, (3) the exhaust fan is operating at the proper speed and turning in the proper direction, (4) the exhaust duct is not restricted, and (5) the fan blades are clear.

NFPA *Standard* 96 design requirements for access to the system should be followed to facilitate cleaning the exhaust hood, ductwork, and fan. Cleaning should be done before grease has built up to 0.25 in. in any part of the system, and by a method that cleans to bare metal. Cleaning agents should be thoroughly rinsed off, and all loose grease particles should be removed, because they can ignite more readily. Agents should not be added to the surface after cleaning, because their textured surfaces merely collect more grease more quickly. Fire-extinguishing systems may need to be disarmed before cleaning, to prevent accidental discharge, and then reset by authorized personnel after cleaning. All access panels removed must be reinstalled after cleaning, with proper gasketing in place to prevent grease leaks and escape of fire.

Supply, Replacement, and Return Air Systems

Normal Operation. The environment in the kitchen area is clear, fresh, comfortable, and free of drafts and excessive air noise.

Abnormal Operation. The kitchen is smoky, choking, hot, and humid, and perhaps very drafty with excessive air noise.

Cleaning/Maintenance. Check that the replacement air system is operating and is providing the correct amount of air to the space. If it is not, the exhaust system cannot operate properly. Check that dampers are set correctly, filters and exchangers are clean, the belts are tight, the fan is turning in the correct direction, and supply and return ductwork and registers are open, with supply air discharging in the correct direction and pattern. If drafts persist, the system may need to be rebalanced. If noise persists in a balanced system, system changes may be required.

Filter cleaning or changing frequency varies widely depending on the quantity of airflow and contamination of local air. Once determined, the cleaning schedule must be maintained.

With replacement air systems, the air-handling unit, coils, and fan are usually cleaned in spring and fall, at the beginning of the seasonal change. More frequent cleaning or better-quality filtering may be required in some contaminated environments. Duct cleaning for the system is on a much longer cycle, but local codes should be checked as stricter requirements are invoked. Ventilation systems should be cleaned by professionals to ensure that none of the expensive system components are damaged. Cleaning companies should be required to carry adequate liability insurance. The International Kitchen Exhaust Cleaning Association (IKECA) and the National Air Duct Cleaners Association (NADCA), both located in Washington, D.C., can provide descriptions of proper cleaning and inspection techniques and lists of their members.

Control Systems (Operation and Safety)

Normal Operation. Control systems should not permit cooking equipment to operate unless both exhaust and replacement air systems are operating and the fire suppression system is armed. With multiple exhaust and replacement air systems, controls maintain the proper balance as cooking equipment is turned on and off. In the event that a fire-suppression system operates, the energy source for the cooking equipment it serves is shut off. On ducted systems, the exhaust fan usually keeps running to remove fire and smoke from building. On ductless systems, the fan may or may not keep running, but a discharge damper closes to keep the flames away from the ceiling. The replacement air system may continue to run, or it may be shut off by a separate local area fire and smoke sensor. If the control system does not operate in this way, changing to this operation should be considered.

Abnormal Operation. Cooking equipment operates when exhaust and supply are turned off, perhaps because the fire suppression system is unarmed or has been bypassed. When extra cooking systems are turned on or off, the operator must remember to manually turn the exhaust and replacement air fans on or off as well.

When exhaust and replacement air systems are not interlocked, the system can be out of balance. This can cause many of the kinds of abnormal operation described for the other systems. With gas-fired cooking equipment, the fire-suppression system may have a false discharge if the exhaust system is not operating. If cooking is permitted when the fire suppression system is inoperable, the chance of a serious fire is greater, and the operator is liable because insurance usually does not cover this situation.

Cleaning/Maintenance. Cleaning is usually restricted to mechanical operators and electrical sensors in the fire-suppression system and within the hood that are exposed to grease. If they become excessively coated with grease, mechanical operators cannot move and sensors cannot sense. The result is decreased control and safety. The mechanical operators should be cleaned as often as required to maintain free movement. Fire-suppression system operators may need to be changed annually rather than cleaned. Check with a local fire-suppression system dealer before attempting to clean any of these components.

Maintaining control systems (presuming they were properly designed) is mostly a matter of checking the performance of the entire system regularly (min. every 3 months) to ensure it is still performing as designed. Mechanical linkages on dampers and cleanliness of sensors should be checked regularly (min. once a month). All electrical screw terminals in the components should be checked for tightness, relay contacts should be checked for cleanliness, and all exposed conducting surfaces should be checked for corrosion on an annual basis.

RESIDENTIAL KITCHEN VENTILATION

Although commercial and residential cooking processes are similar, ventilation requirements and procedures for the two are different. Differences include exhaust airflow rate and installation height. In addition, residential kitchen ventilation has no replacement air requirement, and energy consumption is insignificant because of lower airflow, smaller motors, and intermittent operation.

Residential Cooking Equipment and Processes

Although the physics of the cooking process and the resulting effluent are about the same, residential cooking is done more conservatively. Equipment such as upright broilers and solid-fuel-burning equipment, described in the section on Exhaust Hoods as Group 3 (heavy duty) and Group 4 (extra-heavy duty), is not used. Therefore, the high ventilation rates and ventilation equipment associated with these rates are not found in residential kitchens. On the other hand, cooking effluent and by-products of open flame combustion must be more closely controlled in a residence than in a commercial kitchen because any escaping effluent is dispersed throughout a residence, whereas a commercial kitchen is negatively pressured compared to surrounding spaces. A residence also has a much lower background ventilation rate, so escaping contaminant is more persistent. This situation presents a different challenge because it is not possible to overcome problems by simply increasing the ventilation rate at the cooking process.

Residential cooking always produces a convective plume that carries upward with it both cooking effluent and any by-products of combustion. When present, particles from spatter are so large that they are not removed by ventilation. Residential kitchen hoods depend more on thermal buoyancy than exhaust fans to capture cooking effluent and by-products of combustion.

Hoods and Other Residential Kitchen Ventilation Equipment

Most residential kitchens are ventilated by wall-mounted, conventional range hoods. Overall, they do the best job at the lowest installed cost. A variation is the deep decorative canopy hood, which is usually chosen for aesthetic reasons. The canopy hood is significantly more costly, but somewhat more effective. **Down-draft range-top ventilators** are currently popular in higher-priced homes. These are unusual because they are designed to capture contaminants by producing velocities over the cooking surface greater than those of the convective plume. With sufficient velocity, their operation can be satisfactory; however, with gas cooking, velocity is limited to prevent an adverse effect on the flame.

Kitchen exhaust fans were more widely used in the past, but they are still used and probably will be for several years. Mounted in the wall or ceiling, they ventilate the kitchen generally rather than at the source of contaminant. For general ventilation in all possible kitchen arrangements, 15 air changes per hour (ACH) is typical; for ceiling-mounted fans, this is usually sufficient, but may be marginal for wall-mounted fans.

Continuous low-level ventilation throughout the house is used increasingly as houses are built with greater airtightness and public awareness of the importance of good indoor air quality grows. This continuous ventilation is for a distinctly different purpose than kitchen ventilation. ASHRAE *Standard* 62 recommends 0.35 ACH but not less than 15 cfm per person. Some installations with equipment for continuous ventilation use that same equipment for kitchen ventilation by intermittently boosting the flow to a considerably higher level or by simply running longer to achieve the needed reduction in effluent concentration. These dual-purpose systems require good design for satisfactory operation and seldom achieve the results of a conventional range hood. If kitchen exhaust is introduced into a general ventilation system, bioaerosols must be removed.

Differences Between Commercial and Residential Equipment

Residential hoods usually meet UL *Standard* 507 requirements. Fire-actuated dampers are never part of the hood and are almost never used. Grease filters in residential hoods are much simpler; grease collection through channels is undesirable because inadequate maintenance could allow grease to pool, creating a fire and health hazard.

Conventional residential wall hoods are usually produced with standard height (from 6 to 9 or 12 in.) and standard depth (17 to 22 in.). Width is usually the same as the cooking surface; 30 in. is fairly standard in the United States. The current HUD Manufactured Home Construction and Safety Standards call for 3 in. overhang per side.

Mounting height is usually 18 to 24 in., with some mounted even higher at a sacrifice in collection efficiency. The lower the hood, the more effective the capture; the velocity of the convective plume is not great, and the plume is easily disrupted by air currents and disturbances. Studies show that 18 in. is the minimum height for suitable access to the cooking surface. Some codes call for a minimum of 30 in. from the cooking surface to combustible cabinets. In that case, the bottom of a 6 in. hood can be 24 in. above the cooking surface.

A minimum flow rate (exhaust capacity) of 40 cfm per linear foot of hood width is recommended as a result of informal testing by the Home Ventilating Institute (HVI 1998). Additional capacity, with speed control, is desirable for handling unusually vigorous cooking and cooking mistakes. The airflow can be increased briefly to clear the air.

Exhaust Systems

Residential hoods offer little opportunity for custom design of an exhaust system. A duct connector is built into the hood, and the installation should use the same size duct. A hood includes either an axial or centrifugal fan. The centrifugal fan has higher pressure capabilities, but the axial fan is usually adequate for low-volume hoods. Virtually all residential hoods on the market in the United States have HVI-certified airflow performance.

Replacement (Makeup) Air

The exhaust rate of residential hoods is generally low enough that replacement air systems are not needed, so hoods rely on natural infiltration. This may cause slight negative pressurization of the residence, but it is usually less than that caused by other equipment such as the clothes dryer. Still, penalties for backdrafts through the flue of a combustion appliance are high. If the residence has a gas furnace and water heater, the flue should be checked for adequate flow with all exhaust devices turned on unless the furnace and water heater are of the sealed-combustion type.

Sometimes commercial-style cooking equipment approved for residential use, with its associated higher ventilation requirements, is installed in residences. In such cases, designers should refer to the earlier sections of this chapter, possibly including the section on Replacement (Makeup) Air Systems.

Energy Conservation

The energy cost of residential hoods is quite low because of the short running time and the low rate of exhaust. For example, it typically costs less than \$10 (U.S.) per heating season in Chicago to run a hood and heat the replacement air, based on running at 150 cfm for an hour a day and using gas heat.

Fire Protection for Residential Hoods

Residential hoods must be installed with metal (preferably steel) duct, which should be positioned to prevent grease pooling. Residential hood exhaust ducts are almost never cleaned, and there is no evidence that this causes fires. Several attempts have been made to make fire extinguishers available in residential hoods, but none has met with broad acceptance. In contrast, residential grease fires on the cooking surface are still a problem. Although the fires always ignite at the cooking surface when cooking grease is left unattended and overheats, the hood is sometimes blamed. That problem is not solved with fire-extinguishing equipment.

Maintenance of Residential Kitchen Ventilation Equipment

All UL-listed hoods and kitchen exhaust fans are designed for simple cleaning, which should be done at intervals consistent with the cooking practices of the user. Although cleaning is often thought to be for fire prevention only, it also benefits health by removing nutrients available for the growth of organisms.

REFERENCES

- ASHRAE. 2001. Ventilation for acceptable indoor air quality. ANSI/ASHRAE *Standard* 62-2001.
- ASHRAE. 2001. Ventilation for commercial cooking operations: First public review draft. *Standard* 154P.
- ASTM. 1999. Test method for performance of commercial kitchen ventilation systems. *Standard* F1704-99. American Society for Testing and Materials, West Conshohocken, PA.
- Claar, C.N., R.P. Mazzucchi, and J.A. Heidell. 1985. *The project on restaurant energy performance (PREP)—End use monitoring and analysis*. Office of Building Energy Research and Development. U.S. Department of Energy, Washington, D.C.
- Elovitz, G. 1992. Design considerations to master kitchen exhaust systems. *ASHRAE Transactions* 98(1):1199-1213.

- Fisher, D.F. 1998. New recommended heat gains for commercial cooking equipment. *ASHRAE Transactions* 104(2).
- HUD. Manufactured home construction and safety standards. *Code of Federal Regulations* Title 24, Part 3280. Department of Housing and Urban Development, Washington, D.C.
- HVI. 1998. *Home ventilating guide*. Home Ventilating Institute, Air Movement and Control Association International, Arlington Heights, IL.
- ICC. 1996. *International mechanical code*. International Code Council, Falls Church, VA.
- Kuehn, T.H. 1998. Effects of air velocity on grease deposition in exhaust ductwork. *ASHRAE Research Project* RP-1033.
- Kuehn, T.H., W.D. Gerstler, D.Y.H. Pui, and J.W. Ramsey. 1999. Comparison of emissions from selected commercial kitchen appliances and food products. *ASHRAE Transactions* 105(2):128-141.
- NFPA. 1996. Installation of sprinkler systems. *ANSI/NFPA Standard* 13-96. National Fire Protection Association, Quincy, MA.
- NFPA. 1994. Dry chemical extinguishing systems. *ANSI/NFPA Standard* 17-94. National Fire Protection Association, Quincy, MA.
- NFPA. 1994. Wet chemical extinguishing systems. *ANSI/NFPA Standard* 17A-94. National Fire Protection Association, Quincy, MA.
- NFPA. 1994. Ventilation control and fire protection of commercial cooking operations. *Standard* 96-94. National Fire Protection Association, Quincy, MA.
- Spata, A.J. and S.M. Turgeon. 1995. Impact of reduced exhaust and ventilation rates at 'no-load' cooking conditions in a commercial kitchen during winter operation. *ASHRAE Transactions* 101(2):606-610.
- UL. 1993. Commercial electric cooking appliances. *Standard* 197. Underwriters Laboratories, Northbrook, IL.
- UL. 1996. Fire testing of fire extinguishing systems for protection of restaurant cooking areas, 2nd ed. *Standard* 300-96. Underwriters Laboratories, Northbrook, IL.
- UL. 1994. Electric fans, 8th ed. *ANSI/UL Standard* 507-94. Underwriters Laboratories, Northbrook, IL.
- UL. 1995. Exhaust hoods for commercial cooking equipment, 5th ed. *Standard* 710-95. Underwriters Laboratories, Northbrook, IL.
- UL. 1999. Power roof ventilators for restaurant exhaust appliances. *Standard* 762. Underwriters Laboratories, Northbrook, IL.
- UL. 1979. Grease filters for exhaust ducts, 2nd ed. *Standard* 1046-79. Underwriters Laboratories, Northbrook, IL.
- UL. 1995. Grease ducts, 1st ed. *Standard* 1978-95. Underwriters Laboratories, Northbrook, IL.
- de Albuquerque, A.J. 1972. Equipment loads in laboratories. *ASHRAE Journal* 14(9):59-62.
- Department of Mechanical Engineering, University of Manitoba-BETT Program. 1984. *Analysis of commercial kitchen exhaust systems design and energy conservation*. Report prepared for Energy, Mines and Resources Canada.
- Deppisch, J.R. and L.J. Irwin. 1974. Energy efficiencies of gas and electric range top sections. *Research Report* 1504. American Gas Association Laboratories, Cleveland, OH.
- Donnelly, F. 1966. Preventing fires in kitchen ventilating ducts. *Air Conditioning, Heating and Ventilating* (December).
- Drees, K.H., J.D. Wenger, and G. Janu. 1992. Ventilation airflow measurement for ASHRAE Standard 62-1989. *ASHRAE Journal* 34(10):40-44.
- Electrification Council. 1975. *New electric kitchen ventilation design criteria—Leader's guide*. The Electrification Council, New York.
- EPRI. 1989. Analysis of building codes for commercial kitchen ventilation systems. *Final Report* CU-6321 for National Conference of States on Building Codes and Standards. Electric Power Research Institute, Palo Alto, CA.
- EPRI. 1989. Assessment of building codes, standards and regulations impacting commercial kitchen design. *Final Report* for National Conference of States on Building Codes and Standards. Electric Power Research Institute, Palo Alto, CA.
- EPRI. 1991. Proposed testing protocols for commercial kitchen ventilation research. *Final Report* CU-7210 for Underwriters Laboratories. Electric Power Research Institute, Palo Alto, CA.
- Esmen, N.A., D.A. Wegel, and F.P. McGuigan. 1986. Aerodynamic properties of exhaust hoods. *American Industrial Hygiene Association Journal* 47(8).
- Farnsworth, C.A. and D.E. Fritzsche. 1988. *Improving the ventilation of residential gas ranges*. American Gas Association Laboratories, Cleveland, OH.
- Farnsworth, C., A. Waters, R.M. Kelso, and D. Fritzsche. 1989. Development of a fully vented gas range. *ASHRAE Transactions* 95(1):759-768.
- Fitzgerald, H. 1969. Code reduces kitchen exhaust fires. *Air Conditioning, Heating and Ventilating* (May).
- Frey, D.J., C.N. Claar, and P.A. Oatman. 1989. The model electric restaurant. *Final Report* CU-6702. Electric Power Research Institute, Palo Alto, CA.
- Frey, D.J., K.F. Johnson, and V.A. Smith. 1993. Computer modeling analysis of commercial kitchen equipment and engineered ventilation. *ASHRAE Transactions* 99(2):890-908.
- Fritz, R.L. 1989. A realistic evaluation of kitchen ventilation hood designs. *ASHRAE Transactions* 95(1):769-779.
- Fugler, D. 1989. Canadian research into the installed performance of kitchen exhaust fans. *ASHRAE Transactions* 95(1):753-758.
- Garrett, R.T. 1984. *Commercial/institutional kitchen and makeup air analysis: Design and selection application guide*. Muckler Industries, St. Louis, MO.
- Garrett, R.T. 1987. Psychrometric limitations of exhaust and makeup air conditions associated with commercial kitchen ventilation. *IAQ '87, Practical control of indoor air problems*, pp. 359-371. ASHRAE.
- Garrett, R.T. 1989. Are you willing to save money on heating costs just to blow your air conditioning out the exhaust? *The Consultant* (FCSI) 22(4).
- Gordon, E.B. and N.D. Burk. 1993. A two-dimensional finite-element analysis of a simple commercial kitchen ventilation system. *ASHRAE Transactions* 99(2):909-914.
- Gordon, E.B., D.J. Horton, and F.A. Parvin. 1994. Development and application of a standard test method for the performance of exhaust hoods with commercial cooking appliances. *ASHRAE Transactions* 100(2):988-999.
- Gordon, E.B., D.J. Horton, and F.A. Parvin. 1995. Description of a commercial kitchen ventilation (CKV) laboratory facility. *ASHRAE Transactions* 101(1):249-261.
- Gotoh, N., N. Ohira, T. Fusegi, T. Sakurai, and T. Omori. 1993. A study of ventilation of a kitchen with a range hood fan. *Room air convection and ventilation effectiveness*, pp. 371-377. 1992 ISRACVE, Tokyo, Japan. ASHRAE.
- Greenheck Fan Corporation. 1981. *Cooking equipment ventilation—Application and design*. CEV-5-82. Greenheck Fan Corporation, Schofield, WI.

BIBLIOGRAPHY

- Abrams, S. 1989. Kitchen exhaust systems. *The Consultant* (FCSI) 22(4).
- Alereza, T. and J.P. Breen. 1984. Estimates of recommended heat gains due to commercial appliances and equipment. *ASHRAE Transactions* 89(2A):25-58.
- Annis, J.C. and P.J. Annis. 1989. Size distributions and mass concentrations of naturally generated cooking aerosols. *ASHRAE Transactions* 95(1):735-743.
- Balogh, E.A. 1989. Tandem wet/dry chemical cooking area fire extinguishing concept. *The Consultant* (FCSI) 22(4).
- Bevirt, W.D. 1994. What engineers need to know about testing and balancing. *ASHRAE Transactions* 100(1):705-714.
- Black, D.K. 1989. Commercial kitchen ventilation—Efficient exhaust and heat recovery. *ASHRAE Transactions* 95(1):780-786.
- Capalbo, F.J. 1991. Efficient kitchen ventilation: Grease filters are the key. *The Consultant* (FCSI).
- Chih-Shan, L., L. Wen-Hai, and J. Fu-Tien. 1993. Removal efficiency of particulate matter by a range exhaust fan. *Environmental International* 19:371-380.
- Chih-Shan, L., L. Wen-Hai, and J. Fu-Tien. 1993. Size distributions of sub-micrometer aerosols from cooking. *Environmental International*.
- Cini, J.C. 1989. Innovative kitchen exhaust systems. *The Consultant* (FCSI) 22(4).
- Collison, R. 1979. Energy consumption during cooking. *Journal of Food Technology* 14:173-179.
- Conover, D.R. 1992. Building construction regulation impacts on commercial kitchen ventilation and exhaust systems. *ASHRAE Transactions* 98(1):1227-1235.
- Crabtree, S. 1989. Ventilation: Where less is better. *The Consultant* (FCSI) 22(4).
- Dallavalle, J. 1953. Design of kitchen range hoods. *Heating and Ventilating* (August).

- Guffey, S.E. 1992. A computerized data acquisition and reduction system for velocity traverses in a ventilation laboratory. *ASHRAE Transactions* 98(1):98-106.
- Hane, A.E. 1989. Discussion of ventilation and exhaust hoods. *The Consultant* (FCSI) 22(4).
- Hicks, B. 1989. Who wants ventilation anyway? And why? *The Consultant* (FCSI) 22(4).
- Himmel, R.L. 1983. Effects of ventilation on equipment performance. Commercial cooking equipment improvement, vol. IV. GRI-80/0079.4 *Final Report*. American Gas Association Laboratories, Cleveland, OH.
- Horton, D.J., J.N. Knapp, and E.J. Ladewski. 1993. Combined impact of ventilation rates and internal heat gains on HVAC operating costs in commercial kitchens. *ASHRAE Transactions* 99(2):877-883.
- Jamboretz, J.S. 1982. Before you specify a "no-heat" hood. *The Consultant* (FCSI) 15(2):40.
- Jin, Y. and J.R. Ogilvie. 1992. Isothermal airflow characteristics in a ventilated room with a slot inlet opening. *ASHRAE Transactions* 98(2):296-306.
- Kelso, R.M. and C. Rousseau. 1995. Kitchen ventilation. *ASHRAE Journal* 38(9):32-36.
- Kelso, R.M., L.E. Wilkening, E.G. Schaub, and A.J. Baker. 1992. Computational simulation for kitchen airflows with commercial hoods. *ASHRAE Transactions* 98(1):1219-1226.
- Kim, I.G. and H. Homma. 1992. Possibility for increasing ventilation efficiency with upward ventilation. *ASHRAE Transactions* 98(1):723-729.
- Knapp, J. 1989. Ventilation in the food service industry. *The Consultant* (FCSI) 22(4).
- Knapp, J.N. and W.A. Cheney. 1993. Development of high-efficiency air cleaners for grilling and deep-frying operations. *ASHRAE Transactions* 99(2):884-889.
- Kuehn, T.H., J. Ramsey, H. Han, M. Perkovich, and S. Youssef. 1989. A study of kitchen range exhaust systems. *ASHRAE Transactions* 95(1):744-752.
- Laderoute, M. 1989. Under the hood (don't let fire put you out of business). *The Consultant* (FCSI) 22(4).
- Leipman, M.A. 1989. Who do you trust? *The Consultant* (FCSI) 22(4).
- Levenback, G. 1989. The kitchen ventilation troika: Underwriters Laboratories, National Fire Protection Association, and Council of American Building Officials. *The Consultant* (FCSI) 22(4).
- Lockhart, C. 1989. Restaurant ventilation: Our environmental concerns. *The Consultant* (FCSI) 22(4).
- McGuire, A.B. 1993. Commercial and institutional kitchen exhaust systems. *Heating, Piping and Air Conditioning* (May).
- Murakami, S., S. Kato, T. Tanaka, D.-H. Choi, and T. Kitazawa. 1992. The influence of supply and exhaust openings on ventilation efficiency in an air-conditioned room with a raised floor. *ASHRAE Transactions* 98(1):738-755.
- Niemeier, R.E. 1989. Acoustical considerations for commercial kitchen ventilators. *The Consultant* (FCSI) 22(4).
- Otenbaker, J. 1989. Parting the curtain on ventilation codes: A challenge for specifiers and manufacturers. *The Consultant* (FCSI) 22(4).
- Parikh, J.S. 1989. UL's certification program for restaurant ventilation equipment. *The Consultant* (FCSI) 22(4).
- Parikh, J.S. 1992. Testing and certification of fire and smoke dampers. *ASHRAE Journal* 34(11):30-33.
- Pekkinen, J. and T.H. Takki-Halttunen. 1992. Ventilation efficiency and thermal comfort in commercial kitchens. *ASHRAE Transactions* 98(1):1214-1218.
- Pekkinen, J.S. 1993. Thermal comfort and ventilation effectiveness in commercial kitchens. *ASHRAE Journal* 35(7):35-38.
- Riemenschneider, J. 1989. Ventilation and heat reclaim systems. *The Consultant* (FCSI) 22(4).
- Romano, S. 1989. Kitchen cooking equipment ventilation is a lot of hot air. *The Consultant* (FCSI) 22(4).
- Roy, S., Kelso, R.M., and A.J. Baker. 1994. An efficient CFD algorithm for prediction of contaminant dispersion in room air motion. *ASHRAE Transactions* 100(2):980-987.
- Schaelin, D., J. van der Maas, and A. Moser. 1992. Simulation of airflow through large openings in buildings. *ASHRAE Transactions* 98(2):319-328.
- Schmid, F.P., V.A. Smith, and R.T. Swierczyna. 1997. Schlieren flow visualization in commercial kitchen ventilation research. *ASHRAE Transactions* 103(2):937-942.
- Seller, J. and B. Ward. 1991. *The environment and you*, Part 1. Foodservice Equipment & Supplies Specialist.
- Shaub, E.G., A.J. Baker, N.D. Burk, E.B. Gordon, and P.G. Carswell. 1995. On development of a CFD platform for prediction of commercial kitchen ventilation flow fields. *ASHRAE Transactions* 101(2):581-593.
- Shibata, M., R.H. Howell, and T. Hayashi. 1982. Characteristics and design method for push-pull hoods: Part 2—Streamline analyses of push-pull flows. *ASHRAE Transactions* 88(1):557-570.
- Shute, R.W. 1992. Integrating access floor plenums for HVAC air distribution. *ASHRAE Journal* 34(10):46-51.
- Smith, V.A., D.J. Frey, and C.V. Nicoulin. 1997. Minimum-energy kitchen ventilation for quick service restaurants. *ASHRAE Transactions* 103(2):950-961.
- Smith, V.A., R.T. Swierczyna, and C.N. Claar. 1995. Application and enhancement of the standard test method for the performance of commercial kitchen ventilation systems. *ASHRAE Transactions* 101(2):594-605.
- Smith, V.A. and D.R. Fisher. 2001. Estimating food service loads and profiles. *ASHRAE Transactions* 107(2).
- Snyder, O.P., D.R. Thompson, and J.F. Norwig. 1983. *Comparative gas/electric food service equipment energy consumption ratio study*. University of Minnesota, St. Paul.
- Soling, S.P. and J. Knapp. 1985. Laboratory design of energy efficient exhaust hoods. *ASHRAE Transactions* 91(1B):383-392.
- Swierczyna, R.T., V.A. Smith, and F.P. Schmid. 1997. New threshold exhaust flow rates for capture and containment of cooking effluent. *ASHRAE Transactions* 103(2):943-949.
- Swierczyna, R.T., D.R. Fisher, D.J. Horton. 2002. Effects of commercial kitchen pressure on exhaust system performance. *ASHRAE Transactions* 108(1).
- UL. 1989. *Outline of investigation for power ventilators for restaurant exhaust appliances*, Issue No. 1. Subject 762-89. Underwriters Laboratories, Northbrook, IL.
- VDI Verlag. 1984. *Raumlufttechnische Anlagen für Küchen (Ventilation equipment for kitchens)*. VDI 2052.
- Wolbrink, D.W. and J.R. Sarnosky. 1992. Residential kitchen ventilation—A guide for the specifying engineer. *ASHRAE Transactions* 91(1):1187-1198.
- Wood, C.A. 1989. Hot air. *The Consultant* (FCSI) 22(4).
- Zhang, J. S., G.J. Wu, and L.L. Christianson. 1992. Full-scale experimental results on the mean and turbulent behavior of room ventilation flows. *ASHRAE Transactions* 98(2):307-318.
- Zimmerman, B.A. 1989. Fire dampers... Facts and fallacies. *The Consultant* (FCSI) 22(4).