

CHAPTER 47

SOUND AND VIBRATION CONTROL

Data Reliability	47.1	Sound Control for Outdoor Equipment	47.34
SOUND	47.1	HVAC Noise Reduction Design Procedures	47.35
Acoustical Design of HVAC Systems	47.1	VIBRATION ISOLATION AND CONTROL	47.38
Basic Design Techniques	47.2	Equipment Vibration	47.39
Equipment Sound Levels	47.3	Vibration Criteria	47.39
Duct Element Sound Attenuation	47.13	Specification of Vibration Isolators	47.40
Sound Radiation Through Duct Walls	47.20	Internal Versus External Isolation	47.40
Receiver Room Sound Correction	47.24	Isolation of Vibration and Noise in Piping	
Indoor Sound Criteria	47.26	Systems	47.41
Noise from Plumbing Systems	47.30	Isolating Duct Vibration	47.46
Outdoor Sound Criteria	47.30	Seismic Protection	47.46
Mechanical Equipment Room Sound Isolation	47.31	Vibration Investigations	47.47
Sound Transmission in Return Air Systems	47.32	TROUBLESHOOTING	47.47
Sound Transmission Through Ceilings	47.33	Determining Problem Source	47.47
Fume Hood Duct Design	47.33	Determining Problem Type	47.47

MECHANICAL equipment is one of the major sources of sound in a building. Therefore, the sound generated by mechanical equipment and its effects on the overall acoustical environment in a building must be considered. Mechanical equipment should be selected and equipment spaces designed with an emphasis on both the intended uses of the equipment and the goal of providing acceptable sound and vibration levels in occupied spaces of the building in which the equipment is located.

The system concept of noise control is used throughout this chapter, in that each of the components is thought of as being related to the source-path-receiver chain. The noise generation is the source; it travels from the source via a path, which can be through the air (airborne) or through the structure (structure-borne) until it reaches the ear of the receiver. Noise propagates from the sources through the air distribution duct systems, through the structure, and through combinations of paths, reaching the occupants. Components of the mechanical system from dampers to diffusers to junctions all may produce sound by the nature of the airflow through and around them. As a result, almost all components must be considered. Because sound travels effectively in the same or opposite direction of airflow, downstream and upstream paths are often equally important.

Adequate noise and vibration control in an HVAC system is best achieved during the design phase. ASHRAE Technical Committee 2.6, Sound and Vibration Control, has sponsored research that has greatly expanded the available technical data associated with HVAC acoustics, improving the ability of designers to make more accurate calculations relative to the acoustic characteristics of HVAC systems.

This chapter provides basic sound and vibration principles and data needed by HVAC system designers, and is divided into two main sections, one on sound, the other on vibration. Many of the equations associated with sound and vibration control for HVAC may be found in [Chapter 7 of the ASHRAE Handbook—Fundamentals](#) and in Chapter 42 of the 1991 *ASHRAE Handbook—HVAC Applications*. Additional technical discussions along with detailed HVAC component and system design examples can be found in *Algorithms for HVAC Acoustics* (Reynolds and Bledsoe 1991). There are other significant relevant publications associated

with sound and vibration control in HVAC systems. Related fundamentals associated with sound and vibration in HVAC systems can be found in the *ASHRAE Handbook—Fundamentals*. Specific guidelines for the acoustic design and related construction phases associated with HVAC systems, for troubleshooting sound and vibration problems in HVAC systems, and for HVAC sound and vibration specifications are contained in Schaffer (1991).

DATA RELIABILITY

The data published in this chapter come both from consulting experience and research studies. Use caution when applying the data, especially for situations that extrapolate from the framework of the original research. Although specific uncertainties cannot be stated for each data set, the sound levels or attenuation data are at least within 2 dB of measured or expected results. However, significantly greater variations may occur, especially in the low frequency ranges and particularly in the 63 Hz octave band. Specific data sets may have a wide uncertainty range, but experience suggests that, if done correctly, system estimates that combine data sets usually compare within about 5 dB of measured levels.

SOUND

ACOUSTICAL DESIGN OF HVAC SYSTEMS

The solution to nearly every HVAC system noise and vibration control problem involves examining sound sources, sound transmission paths, and receivers. *Sound sources* are the components that either generate noise, like electric motors, or produce noise when airflow passes by them, like dampers or diffusers. *Paths* are the routes by which the sound travels: through free space, over barriers, along a ducted system. *Receivers* are usually the people who occupy a building. For most HVAC systems, sound sources are associated with the building mechanical and electrical equipment. As indicated in [Figure 1](#), there are many possible sound and/or vibration transmission paths between a sound source and receiver. It is not always possible for HVAC system designers to modify or change the sound source or receiver characteristics. Thus, system designers are most often constrained to modifying the sound transmission paths to achieve desired sound levels in occupied areas of a building.

The preparation of this chapter is assigned to TC 2.6, Sound and Vibration Control.

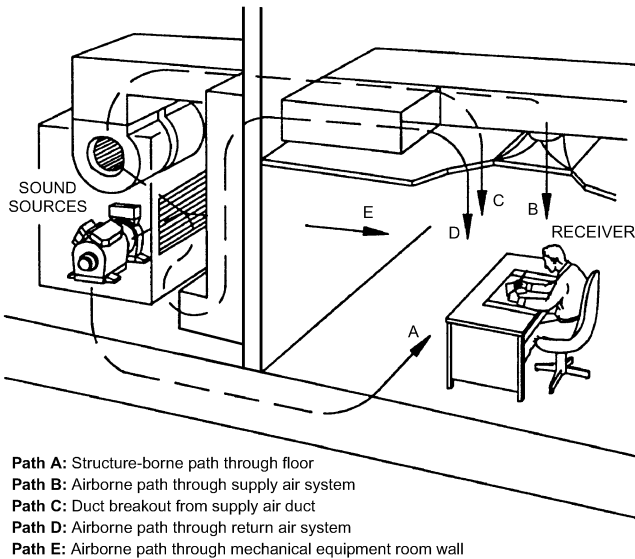

Fig. 1 Typical Paths in HVAC Systems

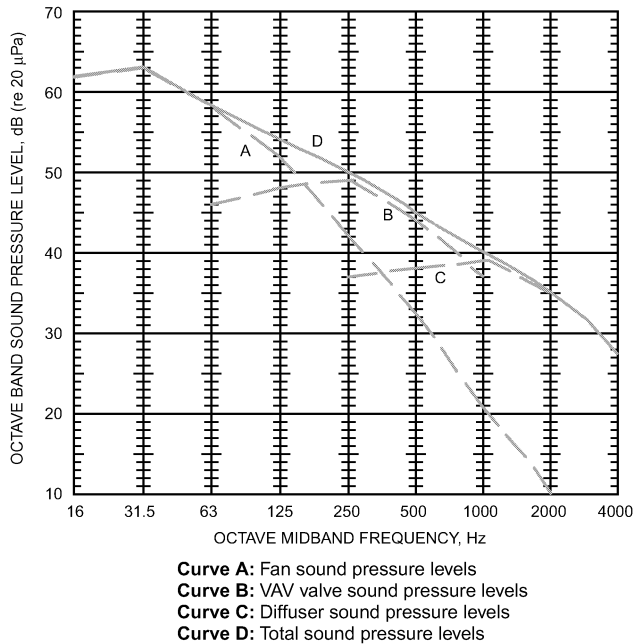

Fig. 2 Illustration of Well-Balanced HVAC Sound Spectrum for Occupied Spaces

Sound sources have different spectral characteristics; that is, different sources produce sounds that have different frequency distributions. For example, as shown in [Figure 2](#), fan noise generally contributes to the sound levels in the 16 Hz through 250 Hz octave bands (curve A). (The frequencies that designate the octave band are often called **octave midband frequencies**.) Variable air volume (VAV) valve noise usually contributes to the sound levels in the 63 Hz through 1000 Hz octave bands (curve B). Diffuser noise usually contributes to the overall HVAC noise in the 250 Hz through 8000 Hz octave bands (curve C and [Figure 4](#)). The overall sound pressure level associated with all of these sound sources combined is shown as curve D.

Occupants may complain when an acceptable sound spectrum is not achieved in an occupied space. [Figure 3](#) shows the frequency

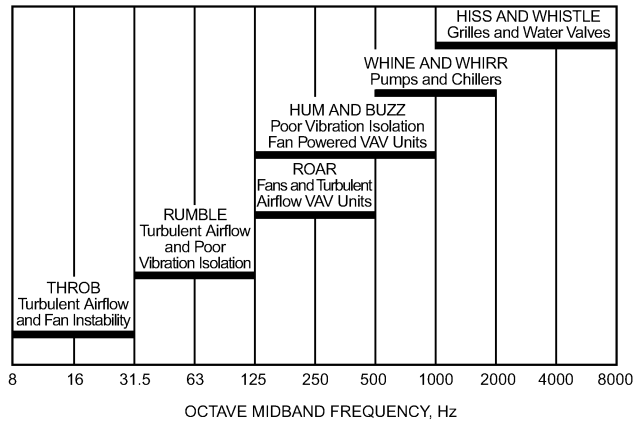

Fig. 3 Frequency Ranges of Likely Sources of Sound-Related Complaints

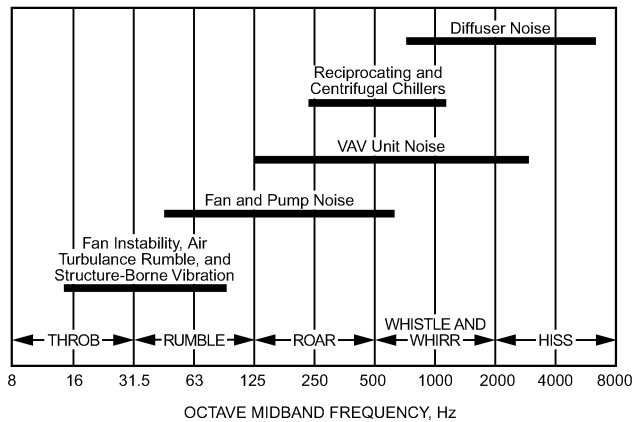

Fig. 4 Frequencies at Which Different Types of Mechanical Equipment Generally Control Sound Spectra

ranges of the most likely sources of HVAC sound-related complaints. [Figure 4](#) shows the frequencies at which different types of mechanical equipment generally control the sound spectra in a room.

BASIC DESIGN TECHNIQUES

When selecting fans and other related mechanical equipment and when designing air distribution systems to minimize the sound transmitted from system components to occupied spaces, consider the following:

- Design the air distribution system to minimize flow resistance and turbulence. High flow resistance increases required fan pressure, which results in higher noise being generated by the fan. Turbulence increases flow noise generated by duct fittings and dampers, especially at low frequencies.
- Select a fan to operate as near as possible to its rated peak efficiency when handling the required airflow and static pressure. Also, select a fan that generates the lowest possible noise at required design conditions. Using an oversized or undersized fan that does not operate at or near rated peak efficiency can substantially increase noise levels.
- Design duct connections at both the fan inlet and outlet for uniform and straight air flow. Both turbulence at the fan inlet and outlet and flow separation at the fan blades can significantly increase the noise generated by the fan. Turning vanes near fan outlets can also increase turbulence and noise, especially if the airflow has not become sufficiently uniform.

Table 1 Sound Sources, Transmission Paths, and Recommended Noise Reduction Methods

Sound Source		Path No.
Circulating fans; grilles; registers; diffusers; unitary equipment in room		1
Induction coil and fan-powered VAV mixing units		1, 2
Unitary equipment located outside of room served; remotely located air-handling equipment, such as fans, blowers, dampers, duct fittings, and air washers		2, 3
Compressors, pumps, and other reciprocating and rotating equipment (excluding air-handling equipment)		4, 5, 6
Cooling towers; air-cooled condensers		4, 5, 6, 7
Exhaust fans; window air conditioners		7, 8
Sound transmission between rooms		9, 10

No.	Transmission Paths	Noise Reduction Methods
1	Direct sound radiated from sound source to ear Reflected sound from walls, ceiling, and floor	Direct sound can be controlled only by selecting quiet equipment. Reflected sound is controlled by adding sound absorption to the room and to equipment location.
2	Air- and structure-borne sound radiated from casings and through walls of ducts and plenums is transmitted through walls and ceiling into room	Design duct and fittings for low turbulence; locate high-velocity ducts in noncritical areas; isolate ducts and sound plenums from structure with neoprene or spring hangers.
3	Airborne sound radiated through supply and return air ducts to diffusers in room and then to listener by Path 1	Select fans for minimum sound power; use ducts lined with sound-absorbing material; use duct silencers or sound plenums in supply and return air ducts.
4	Noise transmitted through equipment room walls and floors to adjacent rooms	Locate equipment rooms away from critical areas; use masonry blocks or concrete for equipment room walls and floor.
5	Vibration transmitted via building structure to adjacent walls and ceilings, from which it radiates as noise into room by Path 1	Mount all machines on properly designed vibration isolators; design mechanical equipment room for dynamic loads; balance rotating and reciprocating equipment.
6	Vibration transmission along pipes and duct walls	Isolate pipe and ducts from structure with neoprene or spring hangers; install flexible connectors between pipes, ducts, and vibrating machines.
7	Noise radiated to outside enters room windows	Locate equipment away from critical areas; use barriers and covers to interrupt noise paths; select quiet equipment.
8	Inside noise follows Path 1	Select quiet equipment.
9	Noise transmitted to an air diffuser in a room, into a duct, and out through an air diffuser in another room	Design and install duct attenuation to match transmission loss of wall between rooms.
10	Sound transmission through, over, and around room partition	Extend partition to ceiling slab and tightly seal all around; seal all pipe, conduit, duct, and other partition penetrations.

- Select duct silencers that do not significantly increase the required fan total static pressure. Selecting silencers with static pressure losses of 0.35 in. of water or less can minimize regenerated noise from silencer airflow.
- Place fan-powered mixing boxes associated with variable-volume air distribution systems away from noise-sensitive areas.
- Minimize flow-generated noise by elbows or duct branch takeoffs whenever possible by locating them at least four to five duct diameters from each other. For high-velocity systems, it may be necessary to increase this distance to up to 10 duct diameters in critical noise areas. Using flow straighteners or honeycomb grids, often called “egg crates,” in the necks of short-length takeoffs that lead directly to grilles, registers, and diffusers is preferred to using volume extractors that protrude into the main duct airflow.
- Keep airflow velocity in the duct as low as possible (1500 fpm or less) near critical noise areas by expanding the duct cross-section area, which will reduce potential flow noise associated with turbulence in these areas. However, do not exceed an included expansion angle of greater than 15°; the resulting flow separation may produce rumble noise.
- Use turning vanes in large 90° rectangular elbows and branch takeoffs. This provides a smoother directional transition, thus reducing turbulence.
- Place grilles, diffusers, and registers into occupied spaces as far as possible from elbows and branch takeoffs.
- Minimize the use of volume dampers near grilles, diffusers, and registers in acoustically critical situations.
- Vibration-isolate all reciprocating and rotating equipment connected to structure. Also, it is usually necessary to vibration-isolate mechanical equipment located in the basement of a building as well as piping supported from the ceiling slab of a basement,

- directly below tenant space. It may be necessary to use flexible piping connectors and flexible electrical conduit between rotating or reciprocating equipment and pipes and ducts that are connected to the equipment.
- Vibration-isolate ducts and pipes, using spring and/or neoprene hangers for at least the first 50 ft from the vibration-isolated equipment.
- Use barriers near outdoor equipment when noise associated with the equipment will disturb adjacent properties. In normal practice, barriers typically produce no more than 15 dB of sound attenuation in the midfrequency range.

Table 1 lists several common sound sources associated with mechanical equipment noise. Anticipated sound transmission paths and recommended noise reduction methods are also listed in the table. Airborne and/or structure-borne sound can follow any or all of the transmission paths associated with a specified sound source. Schaffer (1991) has more detailed information in this area.

EQUIPMENT SOUND LEVELS

Accurate acoustical analysis of HVAC systems depends in part on reliable equipment sound data. These data are often available from equipment manufacturers in the form of sound pressure levels at a specified distance from the equipment or, preferably, equipment sound power levels. Standards used to determine equipment and component sound data are listed at the end of this chapter.

When reviewing manufacturers’ sound data, require certification that the data have been obtained according to one or more of the relevant industry standards. If they have not, the equipment should be rejected in favor of equipment for which data have been obtained

according to relevant industry standards. See Ebbing (1998) for further information.

Fans

Prediction of Fan Sound Power. The sound power generated by a fan performing at a given duty is best obtained from manufacturers' test data taken under approved test conditions (AMCA Standard 300 or ASHRAE Standard 68/AMCA Standard 330). Applications of air-handling products range from stand-alone fans to systems with various modules and attachments. These appurtenances and modules can have a significant effect on air-handler sound power levels. In addition, fans of similar aerodynamic performance can have significant acoustical differences.

Predicting air-handling unit sound power from fan sound levels is difficult. Fan sound determined by tests may be quite different once the fan is installed in an air handler, which in effect creates a new acoustical environment. Proper testing to determine resulting sound power levels once a fan is installed in an air handler is essential. Fan manufacturers are in the best position to supply information on their products, and should be consulted for data when evaluating the acoustic performance of fans for an air handler application. Similarly, air handler manufacturers are in the best position to supply acoustic information on air handlers.

Air handler manufacturers typically provide discharge, inlet, and casing-radiated sound power levels for their units based on one of two methods. The most common method is the **fan-plus-algorithm** method: the fan is tested as a stand-alone item, typically using AMCA Standard 300, and an algorithm is used to predict the effect of the rest of the air-handling unit on the sound as it travels from the fan to the discharge and intake openings or is radiated through a casing with known transmission loss values. Another method is the **ARI 260** method, in which the entire unit is tested in accordance with ARI Standard 260, Sound Rating of Ducted Air Moving and Conditioning Equipment. Under this standard, the entire unit is tested as an assembly, including fans, filters, coils, plenums, casing, etc., and the sound power level at the inlet and discharge openings, as well as the radiated sound power, is measured in a qualified reverberant room. Whenever possible, data obtained by the ARI 260 method should be used because it eliminates much of the uncertainty present in the **fan-plus-algorithm** method.

For a detailed description of fan operations, see [Chapter 18, Fans, in the ASHRAE Handbook—HVAC Systems and Equipment](#).

Different fan types have different noise characteristics and within a fan type, several factors influence noise.

Point of Fan Operation. The point of fan operation has a major effect on acoustical output. Fan selection at the calculated point of maximum efficiency is common practice to ensure minimum power consumption. In general, for a given design, fan sound is at a minimum near the point of maximum efficiency. Noise increases as the operating point shifts to the right as shown in [Figure 5](#) (higher CFM and lower static pressure). Low-frequency noise can increase substantially at operating points to the left (lower CFM and higher static pressure). These operating points should be avoided.

Blade-Pass Frequency. The blade-pass frequency is represented by the number of times per second a fan's impeller passes a stationary item: $f_{bp} = (\text{rpm} \times \text{number of impeller blades})/60$. All fans generate a tone at this frequency and its multiples (harmonics). Whether this tone is objectionable or barely noticeable depends on the type and design of the fan and the point of operation.

Housed Centrifugal Fans. Forward-curved (FC) fans are commonly used in a wide range of standard air-handler products. The blade-pass of FC fans is typically less prominent and is at a higher frequency than other fans. The most distinguishing acoustical concern of FC fans is the prevalent occurrence of low-frequency rumble from airflow turbulence generated at blade tips, which can be exacerbated by nonideal discharge duct conditions (less than five

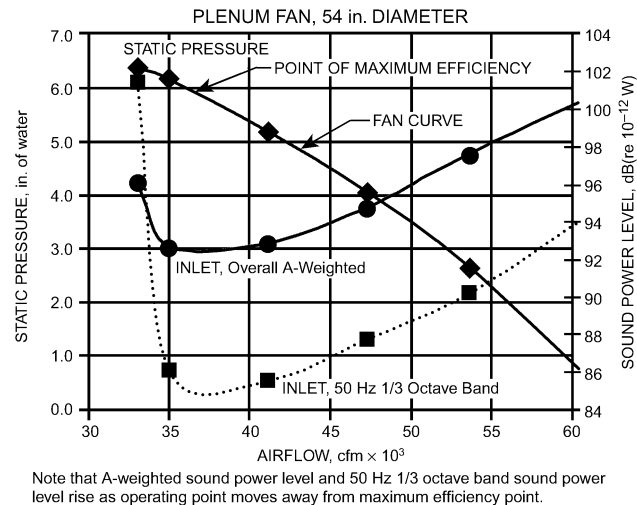

Fig. 5 Test Data for Plenum Fan, Comparing Operating Point (Static Pressure and Airflow), A-Weighted Sound Power Level, and 50 Hz 1/3 Octave Sound Power Level

diameters of straight duct). FC fans are commonly thought to have 16 Hz, 31.5 Hz, and 63 Hz (full octave band) rumble, particularly when operating to the left of the maximum efficiency point.

Backward-inclined (BI) fans and airfoil (AF) fans are generally louder at the blade-pass frequency than a given FC fan selected for the same duty, but are much more energy-efficient at higher pressures and airflow. The blade-pass tone generally increases in prominence with increasing fan speed and is typically in a frequency range that is difficult to attenuate. Below the blade-pass frequency, these fans generally have lower sound amplitude than FC fans and are often quieter at high frequencies.

Care should be taken with all types of housed fans to allow adequate clearance around the inlets. Also note that belt guards will both decrease airflow and increase sound generation.

Plenum Fans. A plenum fan has no housing around the fan impeller and discharges directly into the chamber, pressurizing the plenum, and forcing air through the attached ductwork. Air flows into the fan impeller through an inlet bell located in the chamber wall. These fans can result in substantially lower discharge sound power levels if the fan plenum is appropriately sized and acoustically treated with sound-absorptive material.

The plenum discharge should be located away from the fan's air blast because blowing directly into the duct can aggravate the blade-pass sound. Avoid obstructing the inlet or crowding the coils or filters.

Vaneaxial Fans. Generally thought to have the lowest amplitudes of low-frequency sound of any of the fan types, axial fans are often used in applications where the higher-frequency noise can be managed with attenuation devices. In the useful operating range, the noise from axial fans is a strong function of the inlet airflow symmetry and blade tip speed.

Propeller Fans. Sound from propeller fans generally has a low-frequency-dominated spectrum shape; the blade-pass frequency is typically prominent and occurs in the low-frequency bands because of the small number of blades. Propeller fan blade-pass frequency noise is very sensitive to inlet obstructions. For some propeller fan designs, the shape of the fan venturi (inlet) is also a very important parameter that affects sound levels. In some applications, the noise of a propeller fan is described as sounding like a helicopter. Propeller fans are most commonly used on condensers and for power exhausts.

Minimizing Fan Sound. To minimize the required air distribution system sound attenuation, proper fan selection and installation are vitally important. The following factors should be considered:

- Design the air distribution system for minimum airflow resistance. High system resistance requires fans to operate at a higher brake horsepower, which generates higher sound power levels.
- Carefully analyze system pressure losses. Higher-than-expected system resistance may result in higher sound power levels than originally estimated.
- Examine the sound power levels of different fan types and designs. Select a fan (or fans) that will generate the lowest sound power levels while meeting other fan selection requirements.
- Many fans generate tones at the blade-pass frequency and its harmonics that may require additional acoustical treatment of the system. The amplitude of these tones can be affected by resonance within the duct system, fan design, and inlet flow distortions caused by poor inlet duct design, or by the operation of an inlet volume control damper. When possible, use variable-speed volume control instead of volume control dampers.
- Design duct connections at both the fan inlet and outlet for uniform and straight airflow. Avoid unstable, turbulent, and swirling inlet airflow. Deviation from acceptable practice can severely degrade both the aerodynamic and acoustic performance of any fan and invalidate manufacturers' ratings or other performance predictions.

Variable Air Volume (VAV) Systems

General Design Considerations. As in other aspects of HVAC system design, ducts for VAV systems should be designed for the lowest practical static pressure loss, especially ductwork closest to the fan or air-handling unit (AHU). High airflow velocities and convoluted duct routing with closely spaced fittings can cause turbulent airflow that results in excessive pressure drop and fan instabilities that can cause excessive noise, fan stall, or both.

Many VAV noise complaints have been traced to control problems. Although most of the problems are associated with improper installation, many are caused by poor design. The designer should specify high-quality fans or air handlers within their optimum ranges, not at the edge of their operation ranges where low system tolerances can lead to inaccurate fan flow capacity control. Also, in-duct static pressure sensors should be placed in duct sections having the lowest possible air turbulence (i.e., at least three equivalent duct diameters from any elbow, takeoff, transition, offset, or damper).

Balancing. VAV noise problems have also been traced to improper air balancing. For example, air balance contractors commonly balance an air distribution system by setting all damper positions without considering the possibility of reducing the fan speed. The result is a duct system in which no damper is completely open and the fan is delivering air at a higher static pressure than would otherwise be necessary. If the duct system is balanced with at least one balancing damper wide open, the fan speed and corresponding fan noise could be reduced. Lower sound levels will occur if most balancing dampers are wide open or eliminated. The specified goal should be to balance the system at the lowest static pressure required to operate the box located at the farthest point in the system.

Fan Selection. For constant-volume systems, fans should be selected to operate at maximum efficiency at design airflow. However, VAV systems must be selected to operate with efficiency and stability throughout the operating range. For example, a fan selected for peak efficiency at full output may aerodynamically stall at an operating point of 50% of full output, resulting in significantly increased low-frequency noise. A stalling fan can indicate operation in the **surge region**, a region of operational instability where airflow reverses direction at the fan blade because of insufficient air entering the fan wheel. Similarly, a fan selected to operate most efficiently at the 50% output point may be very inefficient at full output, resulting in substantially increased fan noise at all frequencies. In general, a fan selected for a VAV system should be selected for peak efficiency at an operating point between 70 and 80% of the maximum required system capacity, which is where the fan will operate most of the time.

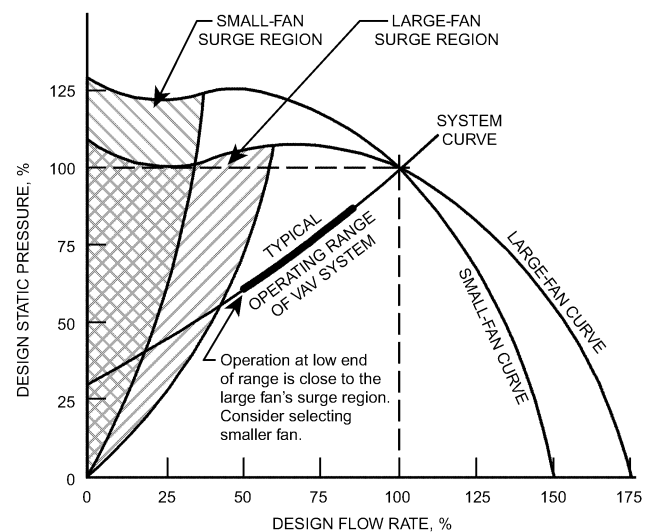

Fig. 6 Basis for Fan Selection in VAV Systems

This usually means selecting a fan that is one size smaller than that required for peak efficiency at 100% of maximum required system capacity (Figure 6). When the smaller fan operates at higher capacities, it will produce up to 5 dB more noise. This occasional increase in sound level is usually more tolerable than stall-related sound problems that can occur with a larger fan operating at less than 100% design capacity most of the time.

Air Modulation Devices. The control method selected to vary the air capacity of a VAV system is important. Variable-capacity control methods can be divided into three general categories: (1) variable inlet vanes (sometimes called inlet guide vanes) or discharge dampers, that yield a new fan system curve at each vane or damper setting, (2) variable-pitch fan blades (usually used on axial fans) that adjust the blade angle for optimum efficiency at varying capacity requirements, and (3) variable-speed motor drives in which motor speed is varied by modulation of the power line frequency or by mechanical means such as gears or continuous belt adjustment. Inlet vane and discharge damper volume controls can add noise to a fan system at reduced capacities, whereas variable-speed motor drives and variable-pitch fan blade systems are quieter at reduced air output than at full air output.

Variable Inlet Vanes and Discharge Dampers. Variable inlet vanes vary airflow capacity by changing the inlet airflow to a fan wheel. This type of air modulation varies the total air volume and pressure at the fan while the fan speed remains constant. Although fan pressure and air volume reductions at the fan result in duct system noise reductions by reducing air velocities and pressures in the duct work, there is an associated increase in fan noise caused by airflow turbulence and flow distortions at the inlet vanes. Fan manufacturers' test data have shown that, on airfoil centrifugal fans, as vanes mounted inside the fan inlet (nested inlet vanes) close, the sound level at the blade-pass frequency of the fan increases by 2 to 8 dB, depending on the percent of total air volume restricted. For externally mounted inlet vanes, the increase is on the order of 2 to 3 dB. Forward-curved fan wheels with inlet vanes are about 1 to 2 dB quieter than airfoil fan wheels. In-line axial fans with inlet vanes generate increased noise levels of 2 to 8 dB in the low-frequency octave bands for a 25 to 50% closed vane position.

Discharge dampers, typically located immediately downstream of the supply air fan, reduce airflow and increase pressure drop across the fan while the fan speed remains constant. Because of air turbulence and flow distortions created by the high pressure drop across discharge dampers, there is a high probability of duct rumble

near the damper location. If the dampers are throttled to a very low flow, a stall condition can occur at the fan, resulting in an increase in low-frequency noise.

Variable-Pitch Fans for Capacity Control. Variable-pitch fan blade controls vary the fan blade angle to reduce the airflow. This type of system is predominantly used in axial fans. As air volume and pressure are reduced at the fan, there is a corresponding noise reduction. In the 125 through 4000 Hz octave bands, this reduction usually varies between 2 to 5 dB for a 20% reduction in air volume, and between 8 to 12 dB for a 60% reduction in air volume.

Variable-Speed Motor Controlled Fan. Three types of electronic variable-speed control units are used with fans: (1) current source inverter, (2) voltage source inverter, and (3) pulse-width modulation (PWM). The current source inverter and third-generation PWM control units are usually the quietest of the three controls. In all three types, matching motors to control units and the quality of the motor windings will determine the noise output of the motor. The motor typically emits a pure tone with an amplitude that depends on the smoothness of the waveform from the line current. The frequency of the motor tone is dependent on the motor type, windings, and speed. Both the inverter control units and motors should be enclosed in areas, such as mechanical rooms or electrical rooms, where the noise impact on surrounding rooms is minimal. The primary acoustic advantage of variable-speed fans is the reduction of fan speed, which translates into reduced noise; dB reduction is approximately equal to 50 [log (Higher Speed/Lower Speed)]. Because this speed reduction generally follows the fan system curve, a fan selected at optimum efficiency initially (lowest noise) will not lose that efficiency as the speed is reduced. The use of variable-speed controllers requires observing the following guidelines:

- Select fan vibration isolators on the basis of the lowest practical speed of the fan. For example, the lowest rotational speed might be 600 rpm for a 1000 rpm fan in a commercial system.
- Select a controller with a feature typically called “critical frequency jump band.” This feature allows a user to program the controller to avoid certain fan or motor RPM settings that might excite vibration isolation system or building structure resonance frequencies, or correspond to speeds of other fans in the same system.
- Check the intersection of the fan’s curve at various speeds against the duct system curve. When selecting a fan that will be controlled by a variable-speed motor controller, keep in mind that the system curve does not go to zero static pressure at no flow. The system curve is asymptotic at the static pressure control set point, typically 1 to 1.5 in. of water. An improperly selected fan may be forced to operate in its stall range at slower fan speeds.

Terminal Units. Fans and pressure-reducing valves in VAV units should have manufacturer-published sound data indicating sound power levels that (1) are discharged from the low-pressure end of the unit and (2) radiate from the exterior shell of the unit. These sound power levels vary as a function of valve position and fan point of operation. Sound data for VAV units should be obtained according to the procedures specified by the latest ARI Standard 880. In critical situations, a mock-up test should be conducted of a production terminal box under project conditions and space finishes. The test is required because minor changes in box motor, fan, or valve components can affect the noise generated by such equipment.

If the VAV unit is located in noncritical areas (such as above a storeroom or corridor), the sound radiated from the shell of the unit may be of no concern. If, however, the unit is located above a critical space and separated from the space by a ceiling with little or no sound transmission loss at low frequencies, the sound radiated from the shell into the space below may exceed the desired noise criterion. In this case, it may be necessary to relocate the unit to a non-

critical area or to enclose it with a construction having a high transmission loss. In general, fan-powered VAV units should not be placed above or near any room with a required sound criterion rating of less than RC 40(N). For further information, see the section on Indoor Sound Criteria.

Systems that permit the use of VAV units that will not completely shut off are often helpful. If too many units in a system shut off simultaneously, excessive duct system pressure at low flow can occur. This condition can sometimes cause a fan to go into stall, resulting in accompanying roar, rumble, and surge. Using “minimum airflow” instead of “shutoff” VAV units will help prevent this condition from occurring.

Rooftop-Mounted Air Handlers

Rooftop air handlers can have unique noise control requirements because these units are often integrated into a lightweight roof construction. Large roof openings are often required for supply and return air duct connections. These ducts run directly from noise-generating rooftop air handlers to the building interior. Generally, there is insufficient space or distance between the roof-mounted equipment and the closest occupied spaces below the roof to apply standard sound control treatments. Rooftop units should be located above spaces that are not acoustically sensitive and should be placed as far as possible from the nearest occupied space. This measure can reduce the amount of sound control treatment necessary to achieve an acoustically acceptable installation.

The five common sound transmission paths associated with rooftop air handlers (Figure 7) are

- Airborne through the bottom of the rooftop unit to spaces below
- Structure-borne from vibrating equipment in the rooftop unit to the building structure
- Ductborne through the supply air duct from the air handler
- Ductborne through return air duct to the air handler
- Duct breakout noise (see the section on Sound Radiation Through Duct Walls)

Airborne paths are associated with casing-radiated sound that passes through the air-handler enclosure and roof structure to the spaces below. Airborne sound can result from air-handler noise or from other equipment components in the rooftop unit. When a rooftop unit is placed over a large opening in the roof structure through which the supply and return air ducts pass, the opening should be limited to two openings sized to accommodate only the supply and return air ducts. These openings should be properly sealed after installation of the ducts. If a large single opening exists under the rooftop unit, it should be structurally, acoustically, and flexibly sealed with one or more layers of gypsum board or other similar material around the supply and return air ducts. Airborne sound

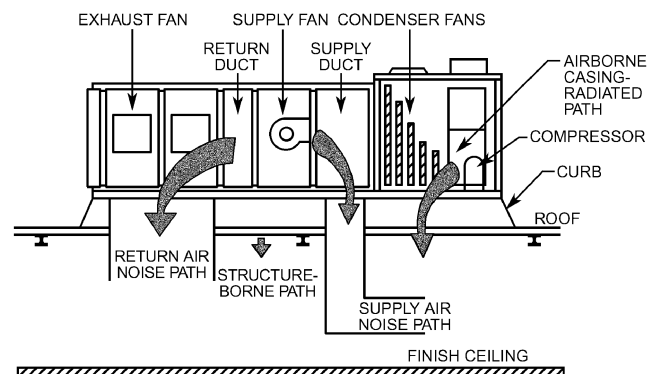

Fig. 7 Sound Paths for Typical Rooftop Installations

transmission to spaces below a rooftop unit can be greatly reduced by placing the rooftop unit on a structural support extending above the roof structure, and running the supply and return air ducts horizontally along the roof for several duct diameters before the ducts turn to penetrate the roof. The roof deck/ceiling system below the unit can be constructed to adequately attenuate the sound radiated from the bottom of the unit.

Using proper vibration isolation can minimize structure-borne sound and vibration from vibrating equipment in a rooftop unit. Special curb mounting bases are available to support and provide vibration isolation for rooftop units. For roofs constructed with open web joists, thin long-span slabs, wooden construction, and any unusually light construction, evaluate all equipment weighing more than 300 lb to determine the additional deflection of the structure at the mounting points caused by the equipment. Isolator deflection should be a minimum of 15 times the additional static deflection. If the required spring isolator deflection exceeds commercially available products, stiffen the supporting structure or change the equipment location.

Ductborne transmission of sound through the supply air duct consists of two components: sound transmitted from the air handler through the supply air duct system to occupied areas, and sound transmitted via duct breakout through a section or sections of the supply air duct close to the air handler to occupied areas. Sound transmission below 250 Hz via duct breakout is often a major acoustical limitation for many rooftop installations. Excessive low-frequency noise associated with fan noise and air turbulence in the region of the discharge section of the fan and the first duct elbow results in duct rumble, which is difficult to attenuate. This problem is often worsened by the presence of a high-aspect-ratio duct at the discharge section of the fan. Rectangular ducts with duct lagging are often ineffective in reducing duct breakout noise. Using either a single- or dual-wall round duct with a radiused elbow coming off the discharge section of the fan can reduce duct breakout. If space does not allow for the use of a single duct, the duct can be split into several parallel round ducts. Another effective method is the use of an acoustic plenum chamber constructed of a minimum 2 in. thick, dual-wall plenum panel, lined with fiberglass and with a perforated inner liner, at the discharge section of the fan. Either round or rectangular ducts can be taken off the plenum as necessary for the rest of the supply air distribution system. [Table 2](#) illustrates 12 possible rooftop discharge duct configurations with their associated low-frequency noise reduction potential (Beatty 1987; Harold 1986, 1991).

Ductborne transmission of sound through the return air duct of a rooftop unit is often a problem because there is generally only one short return air duct section between the plenum space above a ceiling and the return air section of the air handler. This does not allow for adequate sound attenuation between the fan inlet and the spaces below the air handler. Sound attenuation through the return air duct system can be improved by adding at least one (more if possible) branch division where the return air duct is split into two sections that extend several duct diameters before they terminate into the plenum space above the ceiling. The inside surfaces of all return air ducts should be lined with a minimum of 1 in. thick duct liner. If conditions permit, duct silencers in the duct branches or an acoustic plenum chamber at the air-handler inlet section will give better sound conditions.

Aerodynamically Generated Sound in Ducts

Aerodynamic sound is generated when airflow turbulence occurs at duct elements such as duct fittings, dampers, air modulation units, sound attenuators, and room air devices. For details on air modulation units and sound attenuators, see the sections on Variable Air Volume Systems and Duct Silencers.

Although fans are a major source of the sound in HVAC systems, aerodynamically generated sound can often exceed fan sound because of close proximity to the receiver. When making octave-band fan sound calculations using a source-path-receiver

analysis, the aerodynamically generated sound must be added in the path sound calculations at the location of the element.

Duct Velocities. The extent of aerodynamic sound is related to the airflow turbulence and velocity through the duct element. The sound amplitude of aerodynamically generated sound in ducts is proportional to the fifth, sixth, and seventh power of the duct airflow velocity in the vicinity of a duct element (Bullock 1970; Ingard 1968). Therefore, reducing duct airflow velocity significantly reduces flow-generated noise. [Table 3](#) (Schaffer 1991) and [Table 4](#) (Egan 1988) give guidelines for recommended airflow velocities in duct sections and duct outlets to avoid problems associated with aerodynamically generated sound in ducts.

Fixed Duct Fittings. Fixed duct fittings include elbows, tees, transitions, fixed dampers, and branch take-offs. In all cases, less generated air turbulence and lower airflow velocities results in less aerodynamic sound. [Figures 8](#) and [9](#) show typical frequency spectra for specific sizes of elbows and transitions. The data shown in these figures are based on empirical data obtained from ASHRAE RP-37 (Ingard et al. 1968). Normalized data from ASHRAE RP-37 and others, which can apply to all types of duct fittings and dampers, have been published (Bullock 1970) and presented in ASHRAE RP-265 (Ver 1983a). When multiple duct fittings are installed adjacent to each other, aerodynamic sound can increase significantly because of the added air turbulence and increased velocity pressures. It must be noted that the magnitude of the field-measured static pressure drop across fixed duct fittings does not relate to the aerodynamic generated sound. However, the total pressure drop across a duct fitting, which includes the velocity pressure change resulting from air turbulence, does affect the aerodynamically generated sound.











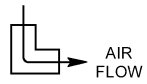







Operable Volume Dampers. Operable damper aerodynamic sound is created because the damper is an obstacle in the airstream, and air turbulence increases as the damper closes. Because total pressure drop across the damper also increases with closure, the aerodynamic sound is related to the total pressure drop. Both single-blade and multiblade dampers, used to balance and control the airflow in a duct system and at room air devices, have similar frequency spectra. [Figure 10](#) shows the frequency spectrum for a 45° damper in a 24 by 24 in. duct (Ingard et al. 1968).

Depending on its location relative to a room air device, a damper can generate sound that is transmitted down the duct to the room air device, or radiate sound through the ceiling space into the occupied space below. When an operable control damper is installed close to an air device to achieve system balance, the acoustic performance of the air outlet must be based not only on the air volume handled, but also on the magnitude of the air turbulence generated at the damper. The sound level produced by closing the damper is accounted for by adding a correction to the air device sound rating. As the damper is modulated for air balance, this quantity is proportional to the pressure ratio (PR), that is, the throttled total pressure drop across the damper divided by the minimum total pressure drop across the damper. [Table 5](#) provides decibel corrections to determine the effect of damper location on linear diffuser sound ratings.

Volume dampers in sound-critical spaces should always be located a minimum of 5 to 10 duct diameters from air device, with an acoustically lined duct between the damper and air device. Acoustically lined plenums may also be used between the damper and room air device to reduce damper sound. Linear air devices with a round duct connected to an insulated plenum have been successfully used for damper sound control. However, acoustical lining in this type of plenum does not minimize the sound generated by air flowing through a short section of the linear air device. If a number of multiple inlets/outlets are used to spread airflow uniformly over the lined plenum and the air device, then the linear slot generates less sound.

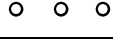
Proper air balancing of a fan/duct system directly affects aerodynamically generated sound even when a duct system has been

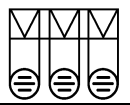
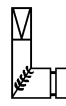
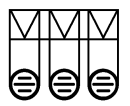
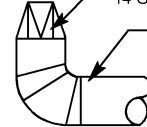
Table 2 Duct Breakout Insertion Loss—Potential Low-Frequency Improvement over Bare Duct and Elbow

Discharge Duct Configuration, 12 ft of Horizontal Supply Duct	Duct Breakout Insertion Loss at Low Frequencies, dB			Side View	End View
	63 Hz	125 Hz	250 Hz		
Rectangular duct: no turning vanes (reference)	0	0	0		22 GAGE 
Rectangular duct: one-dimensional turning vanes	0	1	1		TURNING VANES 
Rectangular duct: two-dimensional turning vanes	0	1	1		TURNING VANES 
Rectangular duct: wrapped with foam insulation and two layers of lead	4	3	5	SEE END VIEW	FOAM INSULATION WITH 2 LAYERS LEAD 
Rectangular duct: wrapped with glass fiber and one layer 5/8 in. gypsum board	4	7	6	SEE END VIEW	GLASS FIBER PRESSED FLAT AGAINST DUCT 
Rectangular duct: wrapped with glass fiber and two layers 5/8 in. gypsum board	7	9	9	SEE END VIEW	GYPSUM BOARD SCREWED TIGHT 
Rectangular plenum drop (12 ga.): three parallel rectangular supply ducts (22 ga.)	1	2	4	12 GAGE 	22 GAGE 
Rectangular plenum drop (12 ga.): one round supply duct (18 ga.)	8	10	6	12 GAGE 	18 GAGE 
Rectangular plenum drop (12 ga.): three parallel round supply ducts (24 ga.)	11	14	8	12 GAGE 	24 GAGE 
Rectangular (14 ga.) to multiple drop: round mitered elbows with turning vanes, three parallel round supply ducts (24 ga.)	18	12	13	24 GAGE 	14 GAGE 
Rectangular (14 ga.) to multiple drop: round mitered elbows with turning vanes, three parallel round lined double-wall, 22 in. OD supply ducts (24 ga.)	18	13	16	24 GAGE 	14 GAGE 
Round drop: radius elbow (14 ga.), single 37 in. diameter supply duct	15	17	10	14 GAGE 18 GAGE 	

correctly designed and installed. Primary volume dampers in the longest duct from a fan should always be nearly wide-open. If the primary damper in the longest duct run is more than 20% closed, the duct system has not been properly air balanced, and the fan may be operating at a higher speed than required for the duct system. The result is an increase in air velocities and turbulence throughout the entire duct system, with excessive aerodynamic sound generated at all duct elements.

Room Air Devices. Manufacturers' test data should be obtained in accordance with ASHRAE *Standard 70* or ARI *Standard 890* for room air devices such as grilles, registers, diffusers, air-handling light fixtures, and air-handling suspension bars. Devices should be selected to meet the noise criterion required or specified for the room. However, the manufacturer's sound power rating is obtained with a uniform velocity distribution throughout the air device neck or grille collar; this is often not met in practice when a duct turn,

sharp transition, or a balancing damper immediately precedes the entrance to the diffuser. In these cases the airflow is turbulent and the noise generated by the device can be substantially higher than the manufacturer's published data by as much as 12 dB. In some cases, placing an equalizer grid in the neck of the air device can substantially reduce this turbulence. The equalizer grid can help provide a uniform velocity gradient within the neck of the device, so the sound power generated in the field will be closer to that listed in the manufacturer's catalog.

At present, air devices are rated by manufacturers in terms of noise criterion (NC) levels, which usually includes a receiver room effect sound correction of 10 dB. The NC ratings may be useful for comparison between different air devices, but are not helpful for source-path-receiver calculations in terms of octave bands. For a complete analysis, the designer should request the component sound

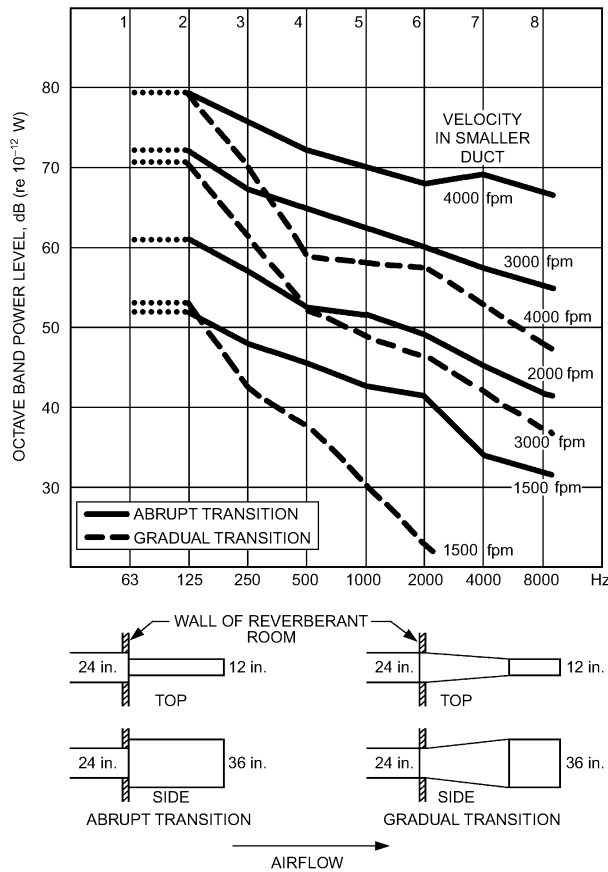
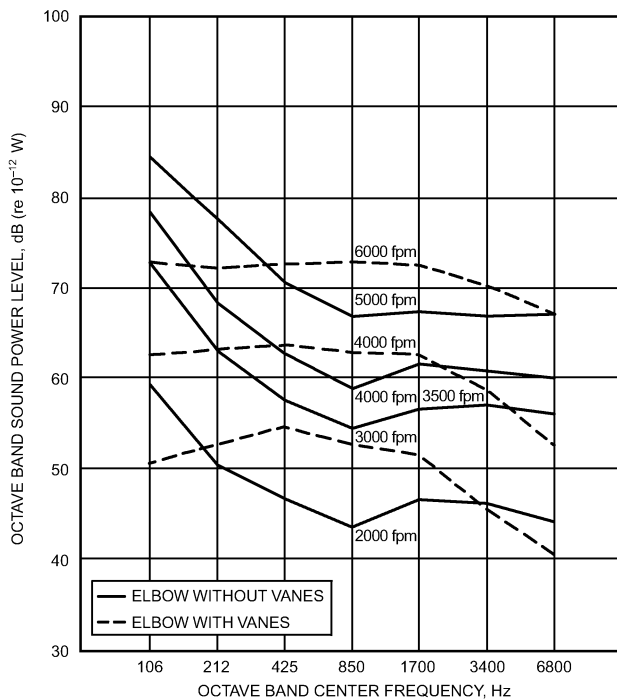

Fig. 8 Velocity-Generated Sound of Duct Transitions



Note: Comparison of octave band sound power levels produced by airflow through 8 x 8 in. rectangular elbow with and without 7 circular arc turning vanes.

Fig. 9 Velocity-Generated Sound of Elbows

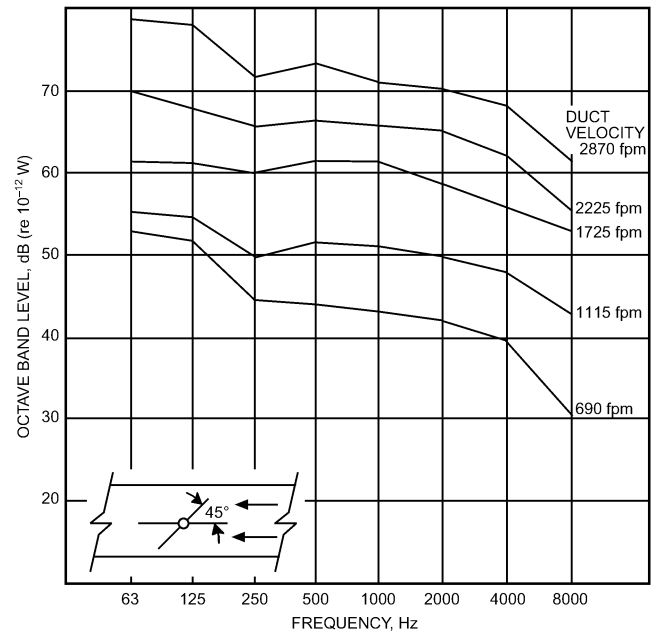

Fig. 10 Velocity-Generated Sound of 24 by 24 in. Volume Damper

Table 3 Maximum Recommended Duct Airflow Velocities Needed to Achieve Specified Acoustic Design Criteria

Main Duct Location	Design RC(N)	Maximum Airflow Velocity, fpm	
		Rectangular Duct	Circular Duct
In shaft or above drywall ceiling	45	3500	5000
	35	2500	3500
	25	1700	2500
Above suspended acoustic ceiling	45	2500	4500
	35	1750	3000
	25	1200	2000
Duct located within occupied space	45	2000	3900
	35	1450	2600
	25	950	1700

Notes:

1. Branch ducts should have airflow velocities of about 80% of the values listed.
2. Velocities in final runouts to outlets should be 50% of the values or less.
3. Elbows and other fittings can increase airflow noise substantially, depending on the type. Thus, duct airflow velocities should be reduced accordingly.

power level data in octave bands from the manufacturer. Whether using NC levels or sound power levels, the designer should also make corrections to manufacturer's data for actual room effect, the location of air devices, and the number of air devices used in a specific design. The acoustical room effect is the reduction in sound level caused by distance from the sound source (e.g., air outlet); the room volume and amount of acoustical absorption present also affect the value. For more information, see the section on Receiver Room Sound Correction. For example, in a small room with an actual calculated room effect of 6 dB, and given a manufacturer's room effect correction of 10 dB, the discrepancy (in this case, 4 dB) must be added to the manufacturer's data. When an air device is located at the intersection of the ceiling and vertical wall, 6 dB should be added, and in the corner of a room, 9 dB should be added to manufacturer's data. When multiple room air devices are located in a small room or grouped together in a large room, the sound of the air devices are additive by up to 10 [log (number of air devices)].

Table 4 Maximum Recommended “Free” Supply Outlet and Return Air Opening Velocities Needed to Achieve Specified Acoustic Design Criteria

Type of Opening	Design RC(N)	“Free” Opening Airflow Velocity, fpm
Supply air outlet	45	625
	40	560
	35	500
	30	425
	25	350
Return air opening	45	750
	40	675
	35	600
	30	500
	25	425

Note: The presence of diffusers or grilles can increase sound levels by varying amounts, depending on how many diffusers or grilles are installed and on their design, construction, and installation. Thus, allowable outlet or opening airflow velocities should be reduced accordingly.

Table 5 Decibels to Be Added to Diffuser Sound Rating to Allow for Throttling of Volume Damper

Location of Volume Damper	Damper Pressure Ratio					
	1.5	2	2.5	3	4	6
	dB to Be Added to Diffuser Sound Rating					
In neck of linear diffuser	5	9	12	15	18	24
In inlet of plenum of linear diffuser	2	3	4	5	6	9
In supply duct at least 5 ft from inlet plenum of linear diffuser	0	0	0	2	3	5

A flexible duct connection between a branch air duct and an air device provides a convenient means to align the air device with the ceiling grid. A misalignment in this connection as shown in [Figure 11](#) can cause as much as 12 to 15 dB higher sound levels in the air device aerodynamic generated sound.

Avoiding Aerodynamically Generated Noise. Aerodynamic noise in duct systems can be avoided by

- Sizing ductwork and duct elements for low air velocities
- Avoiding abrupt changes in duct cross-sectional area or direction
- Providing smooth airflow at all duct elements, including branches, elbows, tees, transitions, and room air devices
- Providing straight ductwork (preferably 5 to 10 duct diameters) between duct elements
- Air-balancing the duct system for the lowest reasonable fan speed with dampers generally open
- Locating volume control dampers a minimum of 5 to 10 duct diameters away from room air devices

Chillers and Air-Cooled Condensers

All chillers and their associated systems produce significant amounts of both broadband and tonal noise. The broadband noise is caused by flows of both refrigerant and water, whereas the tonal noise is caused by the rotation of compressors, motors, and fans (in fan-cooled equipment). Chiller noise is usually significant in the octave bands from 250 through 1000 Hz.

Compressor Types. All compressors, except absorption, produce tonal noise. The acoustical differences among compressors generally relate to their tonal content:

- **Centrifugal compressor** tonal noise comes from the rotation of the impeller and the gears in geared machines. Their tonal content is typically not very strong. However, centrifugal compressor sound pressure level (L_p) values typically increase at reduced chiller capacity because of the extra turbulence induced in the

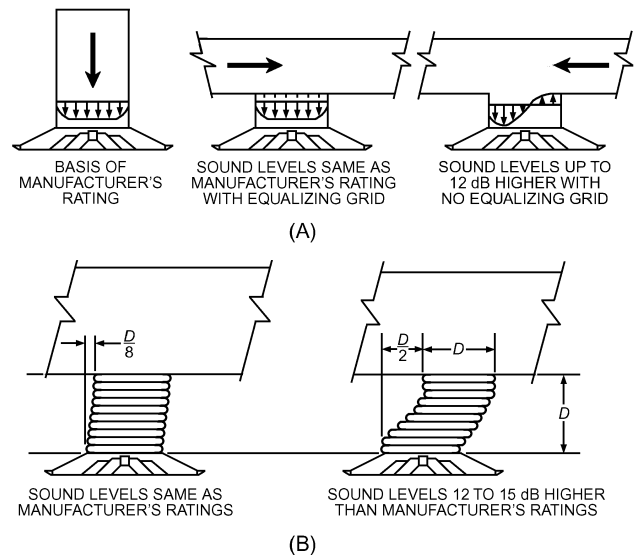

Fig. 11 (A) Proper and Improper Airflow Condition to an Outlet; (B) Effect of Proper and Improper Alignment of Flexible Duct Connector

refrigerant circuit by the inlet vanes. If capacity reduction is achieved via motor speed control, the resulting compressor L_p values decrease with decreasing capacity.

- **Reciprocating compressor** noise has a drumming quality, caused by the oscillating motion of the pistons. The tonal content is high and the sound level decreases very little with decreasing capacity.
- **Absorption chillers** produce relatively little noise themselves, but the flow of steam in associated pumps and valves causes significant high-frequency noise. Noise levels increase with decreasing capacity as valves close. Also, combustion air blowers on direct gas-fired units can be noisy.
- **Scroll compressors** have relatively weak tones; in capacities less than 75 tons, they may not cause noise-related complaints.
- **Screw compressors** (sometimes called helical rotor or rotary compressors) have very strong tones in the 250 through 2000 Hz octave bands. The rotor-induced tones are amplified by resonances in the oil separation circuit and by efficient sound radiation by the condenser and evaporator shells that are rigidly connected to the compressor by high-pressure piping. Screw compressors have been the sources of chiller noise complaints; therefore, this type of compressor requires the most attention during noise and vibration control design.

Indoor Water-Cooled Chillers. The dominant noise source in most water-cooled chillers is the compressor. Water-cooled chillers can use any compressor type, but most use either centrifugal or screw compressors.

Factory sound data for indoor chillers are obtained via ARI *Standard 575*. The standard requires measuring the A-weighted octave band sound pressure level (L_p) values at several locations 3.28 ft from the chiller and 4.92 ft above the floor. ARI 575 ratings are generally available at operating points of 25, 50, and 100% of a chiller's nominal full capacity. The ranges of ARI 575 values for typical centrifugal and screw chillers are shown in [Figures 12](#) and [13](#), respectively.

ARI 575 measurements are usually made in very large rooms with large amounts of sound absorption. Measured levels must be adjusted for each chiller installation to account for the size and surface treatment conditions of the mechanical room. For a given chiller at a given operating point, a small equipment room, or one

with mostly hard surface finishes, will have higher L_p values than a room that is large or has sound-absorbing treatments on its ceiling and walls. Figure 14 shows maximum typical adjustment factors that should be added to factory-provided ARI 575 values to estimate reverberant L_p values in specific installations. The adjustment for each octave band requires knowing the size of an

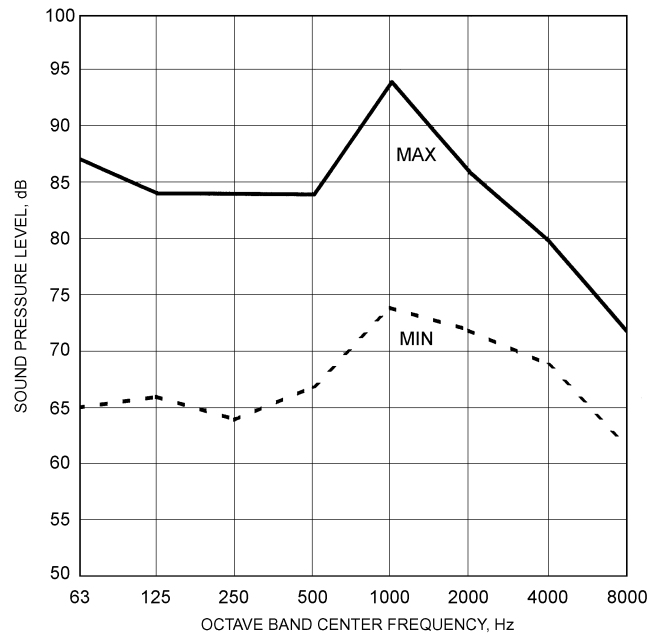

Fig. 12 Typical Minimum and Maximum ARI 575 L_p Values for Centrifugal Chillers (130 to 1300 Tons)

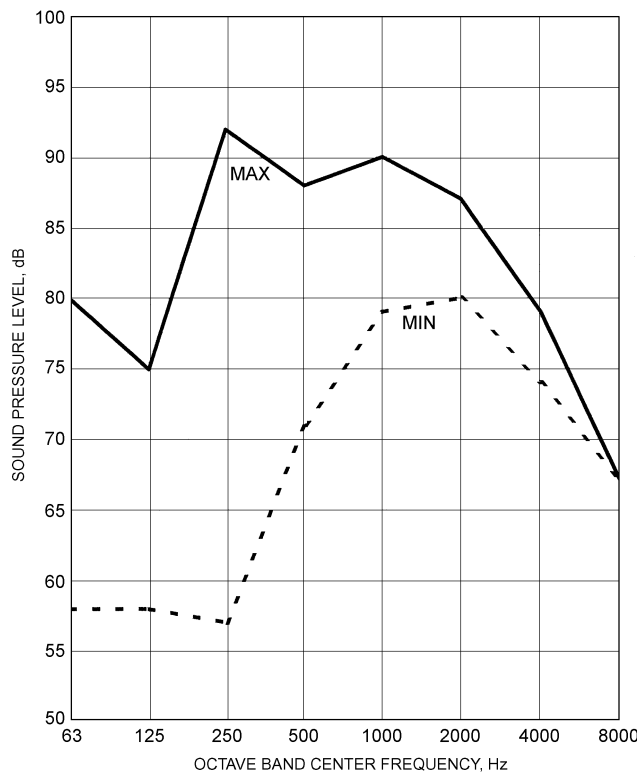

Fig. 13 Typical Minimum and Maximum ARI 575 L_p Values for Screw Chillers (130 to 400 Tons)

imaginary box that is circumscribed one meter away from the top and sides of the chiller (the ARI 575 Measurement Surface), the dimensions of the equipment room, and the average sound absorption coefficient of the room surfaces. The adjustment in each octave band depends on the ratio of the areas of the equipment room and the imaginary box as well as the average sound absorption of the room finishes. Each curve in Figure 14 is for a different value of the average sound absorption, with the higher curves being for lower values.

Example 1. Estimate the reverberant L_p values in a 45 by 40 by 20 ft tall mechanical equipment room (MER) that houses a 360 ton centrifugal chiller. The room has a concrete floor and gypsum board walls and ceiling; all surfaces have an average absorption coefficient of 0.1. The chiller dimensions are 60 in. wide, 80 in. tall, and 120 in. long.

Solution:

The ARI 575 measurement surface area S_M is determined by adding 3.28 ft to the chiller height and 6.56 ft to both its length and width. The floor area is not included in this calculation. The result is a box that has dimensions of 140 in. wide, 200 in. long and 120 in. tall. The surface area of this box is approximately 751 ft². The surface area of the equipment room (floor included) S_R is 7000 ft². Therefore, the ratio of the areas S_R/S_M is 7000/751 = 9.3. Because the average absorption coefficient value for room is 0.1 for all octave bands, refer to Figure 14 for the adjustment factor.

	Octave Midband Frequency, Hz							
	63	125	250	500	1000	2000	4000	8000
ARI 575 L_p values	73	74	73	72	74	72	69	63
Adjustment from Figure 14	7	7	7	7	7	7	7	7
Approximate rev L_p in MER	80	81	80	79	81	79	76	70

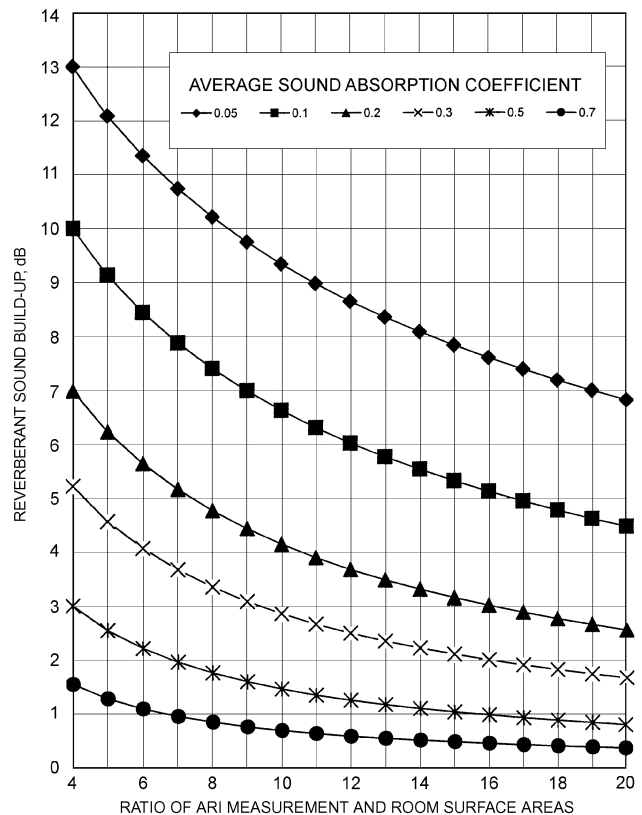

Fig. 14 Estimated dB Buildup in Mechanical Room for ARI 575 Chiller Sound Levels

The approximate reverberant L_p values in the last line of Example 1 can be used along with the sound transmission loss data of the construction to estimate the transmitted L_p values in rooms adjacent to a chiller room.

Indoor chillers are offered with various types of factory noise reduction options for the compressor ranging from compressor blankets (A-weighted noise reduction of 2 to 6) to steel panel enclosures with sound-absorbing inner surfaces (A-weighted noise reduction up to 18). The amount of compressor noise reduction is limited because of structure-borne transmission of compressor vibration into the equipment frame and heat exchanger shells, which act as sounding boards. Most of these options for noise control only reduce tonal characteristics of compressor noise and may not reduce the overall sound power level.

Field noise control options include full-sized sheet metal housing with specially treated openings for piping, electrical conduit, and ventilation. Sometimes upgraded building construction is necessary. For more information refer to the section on Mechanical Equipment Room Sound Isolation.

Outside Air-Cooled Chillers and Air-Cooled Condensers. Most air-cooled chillers use either reciprocating, scroll, or screw compressors. These chillers are also used as the chiller portion of rooftop packaged units. The dominant noise sources in outdoor air-cooled chillers are the compressors and the condenser fans, which are typically low-cost, high-speed propeller fans. Air-cooled condensing units have the propeller fans as their only significant noise source.

Factory sound data for outdoor equipment are obtained in accordance with ARI *Standard 370*, which requires the determination of the equipment's octave band sound power levels (L_w), A-weighted sound power level (L_{wa}), and tone-adjusted A-weighted sound power level (L_{wat}). The range of ARI 370 L_w values for outdoor chillers in the 20 to 380 ton range is given in [Figure 15](#).

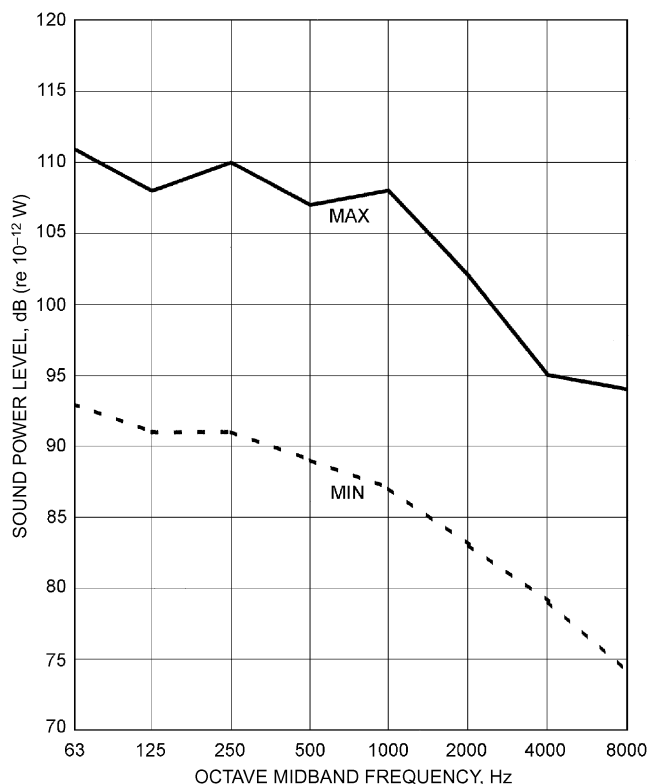

Fig. 15 Typical ARI 370 L_w Values for Outdoor Chillers (20 to 380 Tons)

Factory-supplied noise reduction options for outdoor equipment include compressor enclosures, oversized condenser fans, and variable-speed condenser fans. Because air-cooled equipment needs a free flow of cooling air, full enclosures are not feasible; however, strategically placed barriers can help reduce noise propagation on a selective basis. For more information, see the section on Sound Control for Outdoor Equipment.

Vibration Control. Typical chilled-water systems include not only compressors and fans but also water pumps. The associated piping and conduit vibration generated by compressors and pumps can be transmitted to a building structure through equipment mounts or the attachments of piping/conduit. Therefore, vibration isolation of chiller systems requires essentially floating the entire chiller water system on resilient floor mounts and hangers. Refer to the section on Vibration Isolation and Control for more information on chiller system vibration control.

If a chiller is to be mounted on an on-grade slab, vibration isolators might not be required unless there are nearby noise-sensitive spaces. In noise-sensitive applications (e.g., rooftop chillers over occupied spaces), high-deflection springs or air mounts will likely be required. Potential problems common to all steel spring and rubber pad vibration isolators are wave resonances, phenomena that occur at the natural frequencies of the isolators alone. These are particularly of concern in screw chiller applications because compressor tones typically occur in the same frequency region as the isolator's wave resonances. If one of the compressor tones happens to coincide with one of the isolator resonances, the compressor tone can be readily transmitted into the building structure, causing excessive structure-borne noise in the occupied space near the unit. It is essentially impossible to predict this occurrence in advance; if it does happen, use either another isolator design (with different natural frequencies) or air mounts, which do not exhibit the natural frequency phenomenon.

Emergency Generators

Emergency or standby generators create very high sound levels and require special consideration, especially if used inside an occupied building. The primary noise sources include the engine casing, radiator, and engine exhaust. Each of these sources must be considered separately if the generator is installed inside a building. Sound power levels for these units depend on the power rating, fuel type, engine speed, muffler design, and radiator system. Overall sound power levels can be as high as 130 dBA (re 10^{-12} W) for larger (1.5 to 2.0 MW) diesel-powered units with standard mufflers. Noise levels inside generator rooms almost always exceed 100 dBA if the power rating of the unit is greater than 50 kW.

Noise from the generator casing is broadband with a relatively uniform spectrum. Octave band noise data is usually available from the generator manufacturer. Casing noise does not vary much with load. Conversely, exhaust noise typically contains strong tones at the running frequency of the engine shaft and at the engine firing rate. Standard engine exhaust mufflers reduce exhaust noise by 20 to 25 dBA (compared to unsilenced exhaust), but even with this noise reduction, strong tones still radiate from the exhaust outlet in most cases. High-performance (critical and supercritical grade) mufflers are available but are larger and more expensive than the standard units. Exhaust pipes should be routed away from noise-sensitive areas, and the exhaust outlet should be located and oriented to ensure that community noise levels are not excessive. In occupied buildings, the entire exhaust pipe should be suspended from the structure above with spring hangers.

Engine casing noise is best controlled by enclosing the generator in a concrete enclosure. The biggest problem with generator room design is finding adequate space for ventilation air. Generators require a substantial volume of air for engine cooling, and controlling engine noise transmission via air intake and exhaust paths can be difficult. In most cases, air intake and exhaust openings require

sound attenuators. Because engine radiators usually use propeller fans to move air across the radiator core, the ventilation system cannot always handle the added pressure drop created by sound attenuators. In some cases, auxiliary fans are needed to draw fresh air into the generator room through the intake silencers. Sound attenuators at the discharge opening should be located between the radiator and the exhaust louver. A smooth, slowly expanding transition duct is required between the radiator and the discharge louver. Nonsymmetrical transitions and transitions with expansion angles greater than 15° usually result in nonuniform airflow through the sound attenuators, causing a higher-than-expected pressure drop and reduced airflow. Unless careful space planning is done early in the design phase, there is often not enough space in the generator room to fit the sound attenuators with a proper transition fitting.

Emergency generator radiator fans usually make as much or more noise than the engine casing; in noise-sensitive installations, a remote radiator should be considered. Most manufacturers offer remote radiators as an option, available in a wide variety of designs and noise levels. Lower sound levels with remote radiators are usually achieved by using larger fans running at lower speeds. Using a remote radiator can often provide substantial cost savings in noise-sensitive applications because airflow requirements in the generator room are dramatically reduced.

DUCT ELEMENT SOUND ATTENUATION

Duct elements covered in this section include sound plenums, unlined rectangular ducts, acoustically lined rectangular ducts, unlined round ducts, acoustically lined round ducts, elbows, acoustically lined round radiused elbows, duct silencers, duct branch power division, duct end reflection loss, and terminal volume regulation units. Simplified tabular procedures for obtaining the sound attenuation associated with these elements are presented in this section.

Plenums

Plenum chambers are often used to smooth turbulent airflow as it leaves the outlet section of a fan and before it enters air distribution ducts. Usually placed between the discharge section of a fan and the main air distribution duct, these chambers are typically lined with acoustically absorbent material to reduce fan and other noise. Plenum chambers are usually large rectangular enclosures with an inlet and one or more outlets. Transmission loss associated with a plenum chamber can be expressed as (Wells 1958)

$$TL = -10 \log_{10} \left[S_{out} \left(\frac{Q \cos \theta}{4\pi r^2} + \frac{1 - \alpha_A}{S \alpha_A} \right) \right] \quad (1)$$

where (refer to [Figure 16](#))

- S_{out} = area of plenum outlet, ft²
- S = total inside surface area of plenum minus inlet and outlet areas, ft²
- r = distance between the centers of inlet and outlet of plenum, ft
- Q = directivity factor, which may be taken as 4
- α_A = average absorption coefficient of plenum lining [see Equation (2)]
- θ = angle of vector representing r to long axis l of duct [see Equation (3)]

The average absorption coefficient α_A of plenum lining is given by

$$\alpha_A = \frac{S_1 \alpha_1 + S_2 \alpha_2}{S_1 + S_2} \quad (2)$$

where

- α_1 = sound absorption coefficient of any bare or unlined inside surfaces of plenum
- S_1 = surface area of any bare or unlined inside surfaces of plenum, ft²

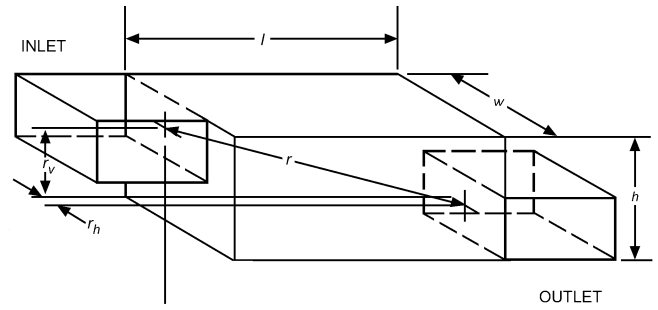

Fig. 16 Schematic of Plenum Chamber

α_2 = sound absorption coefficient of acoustically lined inside surfaces of plenum

S_2 = surface area of acoustically lined inside surfaces of plenum, ft²

In many situations, inside surfaces of a plenum chamber are lined with a sound absorbing material. For these situations, $\alpha_A = \alpha_2$. [Table 6](#) gives sound absorption coefficients for selected common plenum materials.

The value of $\cos \theta$ is obtained from

$$\cos \theta = \frac{l}{r} = \frac{l}{\sqrt{l^2 + r_v^2 + r_h^2}} \quad (3)$$

where (refer to [Figure 16](#))

l = length of plenum, ft

r_v = vertical offset between axes of plenum inlet and outlet, ft

r_h = horizontal offset between axes of plenum inlet and outlet, ft

Equation (1) treats a plenum as a large enclosure. Thus, Equation (1) is only valid where the wavelength of sound is small compared to the characteristic dimensions of the plenum. For frequencies that correspond to plane wave propagation in the duct, the results predicted by Equation (1) are usually not valid. Plane wave propagation in a duct exists at frequencies below

$$f_{co} = \frac{c}{2a} \quad (4)$$

or

$$f_{co} = 0.586 \frac{c}{d} \quad (5)$$

where

f_{co} = cutoff frequency, Hz

c = speed of sound in air, ft/s

a = larger cross-section dimension of rectangular duct, ft

d = diameter of round duct, ft

The cutoff frequency f_{co} is the frequency above which plane waves no longer propagate in a duct. At these higher frequencies, waves that propagate in the duct are called cross or spinning modes. At frequencies below f_{co} , Equation (1) yields conservative results. The actual attenuation usually exceeds values given by Equation (1) by 5 to 10 dB. Equation (1) applies at frequencies of 250 Hz and higher, with an unknown level of accuracy.

Example 2. A plenum chamber is 6 ft high, 4 ft wide, and 6 ft long. The configuration of the plenum is similar to that shown in [Figure 16](#). The inlet and outlet are each 36 in. wide by 24 in. high. The horizontal distance between centers of the plenum inlet and outlet is 1 ft. The vertical distance is 4 ft. The plenum is lined with 1 in. thick 3.0 lb/ft³ density fiberglass insulation board. 100% of the inside surfaces of the plenum is lined with the fiberglass insulation. Determine the transmission loss associated with this plenum. (See [Table 6](#) for the values of the absorption coefficients.)

Table 6 Sound Absorption Coefficients of Selected Plenum Materials

	Octave Midband Frequency, Hz						
	63	125	250	500	1000	2000	4000
Non-Sound-Absorbing Material							
Concrete	0.01	0.01	0.01	0.02	0.02	0.02	0.03
Bare sheet metal	0.04	0.04	0.04	0.05	0.05	0.05	0.07
Sound-Absorbing Material (Fiberglass Insulation Board)							
1 in., 3.0 lb/ft ³	0.05	0.11	0.28	0.68	0.90	0.93	0.96
2 in., 3.0 lb/ft ³	0.10	0.17	0.86	1.00	1.00	1.00	1.00
3 in., 3.0 lb/ft ³	0.30	0.53	1.00	1.00	1.00	1.00	1.00
4 in., 3.0 lb/ft ³	0.50	0.84	1.00	1.00	1.00	1.00	0.97

Note: The 63 Hz values are estimated from higher frequency values.

Solution:

The areas of the inlet section, outlet section, and plenum cross section are

$$S_{in} = \frac{24 \times 36}{144} = 6 \text{ ft}^2$$

$$S_{out} = \frac{24 \times 36}{144} = 6 \text{ ft}^2$$

$$S_{pl} = 4 \times 6 = 24 \text{ ft}^2$$

$l = 6 \text{ ft}$; $r_v = 4 \text{ ft}$; and $r_h = 1 \text{ ft}$. The values of r and $\cos \theta$ are

$$r = \sqrt{6^2 + 4^2 + 1^2} = 7.28 \text{ ft}$$

$$\cos \theta = \frac{6}{7.28} = 0.824$$

The total inside surface area of the plenum is

$$S = 2(4 \times 6) + 2(4 \times 6) + 2(6 \times 6) - (6 + 6) = 156 \text{ ft}^2$$

The value of f_{co} is

$$f_{co} = \frac{1125}{2 \times 3} = 187.5 \text{ Hz}$$

The results are tabulated as follows:

	Octave Midband Frequency, Hz						
	63	125	250	500	1000	2000	4000
$Q \cos \theta / 4\pi r^2$	—	—	0.0050	0.0050	0.0050	0.0050	0.0050
$(1 - \alpha_A) / S \alpha_A$	—	—	0.0165	0.0030	0.0007	0.0005	0.0003
$TL, \text{ dB}$	—	—	9	13	15	15	15

Unlined Rectangular Sheet Metal Ducts

Straight, unlined rectangular sheet metal ducts provide a fairly significant amount of low-frequency sound attenuation. [Table 7](#) shows the results of selected unlined rectangular sheet metal ducts (Cummings 1983; Reynolds and Bledsoe 1989a; Ver 1978; Woods Fan Division 1973). The attenuation values in [Table 7](#) apply only to rectangular sheet metal ducts with the lightest gages allowed by Sheet Metal and Air Conditioning Contractors' National Association, Inc. (SMACNA) HVAC duct construction standards.

Sound energy attenuated at low frequencies in rectangular ducts may manifest itself as breakout noise along the duct. Low-frequency breakout noise should therefore be checked. For additional information on breakout noise, see the section on Sound Radiation Through Duct Walls.

Table 7 Sound Attenuation in Unlined Rectangular Sheet Metal Ducts

Duct Size, in. × in.	P/A 1/ft	Attenuation, dB/ft Octave Midband Frequency, Hz			
		63	125	250	>250
6 × 6	8.0	0.30	0.20	0.10	0.10
12 × 12	4.0	0.35	0.20	0.10	0.06
12 × 24	3.0	0.40	0.20	0.10	0.05
24 × 24	2.0	0.25	0.20	0.10	0.03
48 × 48	1.0	0.15	0.10	0.07	0.02
72 × 72	0.7	0.10	0.10	0.05	0.02

Acoustically Lined Rectangular Sheet Metal Ducts

Internal duct lining for rectangular sheet metal ducts can be used to attenuate sound in ducts and to thermally insulate ducts. The thickness of duct linings for thermal insulation usually varies from 0.5 to 2 in. The density of the fiberglass lining usually varies between 1.5 and 3.0 lb/ft³, but may be as low as 0.75 lb/ft³. For fiberglass duct lining to attenuate fan sound effectively, it should have a minimum thickness of 1 in. [Tables 8](#) and [9](#) give attenuation values of selected rectangular sheet metal ducts for 1 and 2 in. duct lining, respectively (Kuntz 1986; Kuntz and Hoover 1987; Machen and Haines 1983; Reynolds and Bledsoe 1989a). Note that the attenuation values shown in these tables are based on laboratory tests using 10 ft lengths of duct; for designs incorporating other distances, actual dB/ft will be different. The total attenuated noise will never be below the generated noise level in the duct.

The **insertion loss** values in [Tables 8](#) and [9](#) are the difference in the sound pressure level measured in a reverberation room with sound propagating through an unlined section of rectangular duct minus the corresponding sound pressure level measured when the unlined section of rectangular duct is replaced with a similar section of acoustically lined rectangular duct. The net result is the attenuation resulting from the addition of duct liner to a sheet metal duct.

Insertion loss and attenuation values discussed in this section apply only to rectangular sheet metal ducts made with the lightest gages allowed by SMACNA HVAC duct construction standards.

Unlined Round Sheet Metal Ducts

As with unlined rectangular ducts, unlined round ducts provide some natural sound attenuation that should be taken into account when designing a duct system. Compared to rectangular ducts, round ducts are much more rigid and thus do not absorb as much sound energy. Because of this, round ducts only provide about one-tenth the sound attenuation at low frequencies as rectangular ducts. However, breakout from round ducts is significantly less than that from other shapes. [Table 10](#) lists sound attenuation values for unlined round ducts (Kunz and Hoover 1987; Woods Fan Division 1973).

Acoustically Lined Round Sheet Metal Ducts

The literature provides very little data on insertion loss for acoustically lined round ducts; usually only manufacturer's product data are available. [Tables 11](#) and [12](#) give insertion loss values for dual-wall round sheet metal ducts with 1 and 2 in. acoustical lining, respectively (Reynolds and Bledsoe 1989b). The acoustical lining is a 0.75 lb/ft³ density fiberglass blanket, and the fiberglass is covered by an internal liner of perforated galvanized sheet metal with an open area of 25%. The data in [Tables 11](#) and [12](#) were collected from 20 ft duct sections.

Rectangular Sheet Metal Duct Elbows

[Table 13](#) displays insertion loss values for unlined and lined square elbows without turning vanes (Beranek 1960). For lined

Table 8 Insertion Loss for Rectangular Sheet Metal Ducts with 1 in. Fiberglass Lining

Dimensions, in. × in.	Insertion Loss, dB/ft Octave Midband Frequency, Hz					
	125	250	500	1000	2000	4000
6 × 6	0.6	1.5	2.7	5.8	7.4	4.3
6 × 10	0.5	1.2	2.4	5.1	6.1	3.7
6 × 12	0.5	1.2	2.3	5.0	5.8	3.6
6 × 18	0.5	1.0	2.2	4.7	5.2	3.3
8 × 8	0.5	1.2	2.3	5.0	5.8	3.6
8 × 12	0.4	1.0	2.1	4.5	4.9	3.2
8 × 16	0.4	0.9	2.0	4.3	4.5	3.0
8 × 24	0.4	0.8	1.9	4.0	4.1	2.8
10 × 10	0.4	1.0	2.1	4.4	4.7	3.1
10 × 16	0.4	0.8	1.9	4.0	4.0	2.7
10 × 20	0.3	0.8	1.8	3.8	3.7	2.6
10 × 30	0.3	0.7	1.7	3.6	3.3	2.4
12 × 12	0.4	0.8	1.9	4.0	4.1	2.8
12 × 18	0.3	0.7	1.7	3.7	3.5	2.5
12 × 24	0.3	0.6	1.7	3.5	3.2	2.3
12 × 36	0.3	0.6	1.6	3.3	2.9	2.2
15 × 15	0.3	0.7	1.7	3.6	3.3	2.4
15 × 22	0.3	0.6	1.6	3.3	2.9	2.2
15 × 30	0.3	0.5	1.5	3.1	2.6	2.0
15 × 45	0.2	0.5	1.4	2.9	2.4	1.9
18 × 18	0.3	0.6	1.6	3.3	2.9	2.2
18 × 28	0.2	0.5	1.4	3.0	2.4	1.9
18 × 36	0.2	0.5	1.4	2.8	2.2	1.8
18 × 54	0.2	0.4	1.3	2.7	2.0	1.7
24 × 24	0.2	0.5	1.4	2.8	2.2	1.8
24 × 36	0.2	0.4	1.2	2.6	1.9	1.6
24 × 48	0.2	0.4	1.2	2.4	1.7	1.5
24 × 72	0.2	0.3	1.1	2.3	1.6	1.4
30 × 30	0.2	0.4	1.2	2.5	1.8	1.6
30 × 45	0.2	0.3	1.1	2.3	1.6	1.4
30 × 60	0.2	0.3	1.1	2.2	1.4	1.3
30 × 90	0.1	0.3	1.0	2.1	1.3	1.2
36 × 36	0.2	0.3	1.1	2.3	1.6	1.4
36 × 54	0.1	0.3	1.0	2.1	1.3	1.2
36 × 72	0.1	0.3	1.0	2.0	1.2	1.2
36 × 108	0.1	0.2	0.9	1.9	1.1	1.1
42 × 42	0.2	0.3	1.0	2.1	1.4	1.3
42 × 64	0.1	0.3	0.9	1.9	1.2	1.1
42 × 84	0.1	0.2	0.9	1.8	1.1	1.1
42 × 126	0.1	0.2	0.9	1.7	1.0	1.0
48 × 48	0.1	0.3	1.0	2.0	1.2	1.2
48 × 72	0.1	0.2	0.9	1.8	1.0	1.0
48 × 96	0.1	0.2	0.8	1.7	1.0	1.0
48 × 144	0.1	0.2	0.8	1.6	0.9	0.9

Table 9 Insertion Loss for Rectangular Sheet Metal Ducts with 2 in. Fiberglass Lining

Dimensions, in. × in.	Insertion Loss, dB/ft Octave Midband Frequency, Hz					
	125	250	500	1000	2000	4000
6 × 6	0.8	2.9	4.9	7.2	7.4	4.3
6 × 10	0.7	2.4	4.4	6.4	6.1	3.7
6 × 12	0.6	2.3	4.2	6.2	5.8	3.6
6 × 18	0.6	2.1	4.0	5.8	5.2	3.3
8 × 8	0.6	2.3	4.2	6.2	5.8	3.6
8 × 12	0.6	1.9	3.9	5.6	4.9	3.2
8 × 16	0.5	1.8	3.7	5.4	4.5	3.0
8 × 24	0.5	1.6	3.5	5.0	4.1	2.8
10 × 10	0.6	1.9	3.8	5.5	4.7	3.1
10 × 16	0.5	1.6	3.4	5.0	4.0	2.7
10 × 20	0.4	1.5	3.3	4.8	3.7	2.6
10 × 30	0.4	1.3	3.1	4.5	3.3	2.4
12 × 12	0.5	1.6	3.5	5.0	4.1	2.8
12 × 18	0.4	1.4	3.2	4.6	3.5	2.5
12 × 24	0.4	1.3	3.0	4.3	3.2	2.3
12 × 36	0.4	1.2	2.9	4.1	2.9	2.2
15 × 15	0.4	1.3	3.1	4.5	3.3	2.4
15 × 22	0.4	1.2	2.9	4.1	2.9	2.2
15 × 30	0.3	1.1	2.7	3.9	2.6	2.0
15 × 45	0.3	1.0	2.6	3.6	2.4	1.9
18 × 18	0.4	1.2	2.9	4.1	2.9	2.2
18 × 28	0.3	1.0	2.6	3.7	2.4	1.9
18 × 36	0.3	0.9	2.5	3.5	2.2	1.8
18 × 54	0.3	0.8	2.3	3.3	2.0	1.7
24 × 24	0.3	0.9	2.5	3.5	2.2	1.8
24 × 36	0.3	0.8	2.3	3.2	1.9	1.6
24 × 48	0.2	0.7	2.2	3.0	1.7	1.5
24 × 72	0.2	0.7	2.0	2.9	1.6	1.4
30 × 30	0.2	0.8	2.2	3.1	1.8	1.6
30 × 45	0.2	0.7	2.0	2.9	1.6	1.4
30 × 60	0.2	0.6	1.9	2.7	1.4	1.3
30 × 90	0.2	0.5	1.8	2.6	1.3	1.2
36 × 36	0.2	0.7	2.0	2.9	1.6	1.4
36 × 54	0.2	0.6	1.9	2.6	1.3	1.2
36 × 72	0.2	0.5	1.8	2.5	1.2	1.2
36 × 108	0.2	0.5	1.7	2.3	1.1	1.1
42 × 42	0.2	0.6	1.9	2.6	1.4	1.3
42 × 64	0.2	0.5	1.7	2.4	1.2	1.1
42 × 84	0.2	0.5	1.6	2.3	1.1	1.1
42 × 126	0.1	0.4	1.6	2.2	1.0	1.0
48 × 48	0.2	0.5	1.8	2.5	1.2	1.2
48 × 72	0.2	0.4	1.6	2.3	1.0	1.0
48 × 96	0.1	0.4	1.5	2.1	1.0	1.0
48 × 144	0.1	0.4	1.5	2.0	0.9	0.9

square elbows, duct lining must extend at least two duct widths w beyond the elbow. [Table 13](#) applies only where the duct is lined before and after the elbow. [Table 14](#) gives insertion loss values for unlined radiused elbows. [Table 15](#) gives insertion loss values for unlined and lined square elbows with turning vanes. The quantity f/w in [Tables 13, 14, and 15](#) is the midfrequency of the octave band times the width of the elbow ([Figure 17](#)) (Beranek 1960; Ver 1983b).

Nonmetallic Insulated Flexible Ducts

Nonmetallic insulated flexible ducts can significantly reduce airborne noise. Insertion loss values for specified duct diameters and lengths are given in [Table 16](#) (ARI *Standard* 885). Recommended duct lengths are normally from 3 to 6 ft. Care should be taken to keep flexible ducts straight; bends should have as long a radius as possible. Although an abrupt bend may provide some

Table 10 Sound Attenuation in Straight Round Ducts

Diameter, in.	Attenuation, dB/ft Octave Midband Frequency, Hz						
	63	125	250	500	1000	2000	4000
$D \leq 7$	0.03	0.03	0.05	0.05	0.10	0.10	0.10
$7 < D \leq 15$	0.03	0.03	0.03	0.05	0.07	0.07	0.07
$15 < D \leq 30$	0.02	0.02	0.02	0.03	0.05	0.05	0.05
$30 < D \leq 60$	0.01	0.01	0.01	0.02	0.02	0.02	0.02

additional insertion loss, the airflow-generated noise associated with the airflow in the bend may be unacceptably high. Because of potentially high breakout sound levels associated with flexible ducts, care should be exercised when using flexible ducts above sound-sensitive spaces.

Table 11 Insertion Loss for Acoustically Lined Round Ducts with 1 in. Lining

Diameter, in.	Insertion Loss, dB/ft Octave Midband Frequency, Hz							
	63	125	250	500	1000	2000	4000	8000
6	0.38	0.59	0.93	1.53	2.17	2.31	2.04	1.26
8	0.32	0.54	0.89	1.50	2.19	2.17	1.83	1.18
10	0.27	0.50	0.85	1.48	2.20	2.04	1.64	1.12
12	0.23	0.46	0.81	1.45	2.18	1.91	1.48	1.05
14	0.19	0.42	0.77	1.43	2.14	1.79	1.34	1.00
16	0.16	0.38	0.73	1.40	2.08	1.67	1.21	0.95
18	0.13	0.35	0.69	1.37	2.01	1.56	1.10	0.90
20	0.11	0.31	0.65	1.34	1.92	1.45	1.00	0.87
22	0.08	0.28	0.61	1.31	1.82	1.34	0.92	0.83
24	0.07	0.25	0.57	1.28	1.71	1.24	0.85	0.80
26	0.05	0.22	0.53	1.24	1.59	1.14	0.79	0.77
28	0.03	0.19	0.49	1.20	1.46	1.04	0.74	0.74
30	0.02	0.16	0.45	1.16	1.33	0.95	0.69	0.71
32	0.01	0.14	0.42	1.12	1.20	0.87	0.66	0.69
34	0	0.11	0.38	1.07	1.07	0.79	0.63	0.66
36	0	0.08	0.35	1.02	0.93	0.71	0.60	0.64
38	0	0.06	0.31	0.96	0.80	0.64	0.58	0.61
40	0	0.03	0.28	0.91	0.68	0.57	0.55	0.58
42	0	0.01	0.25	0.84	0.56	0.50	0.53	0.55
44	0	0	0.23	0.78	0.45	0.44	0.51	0.52
46	0	0	0.20	0.71	0.35	0.39	0.48	0.48
48	0	0	0.18	0.63	0.26	0.34	0.45	0.44
50	0	0	0.15	0.55	0.19	0.29	0.41	0.40
52	0	0	0.14	0.46	0.13	0.25	0.37	0.34
54	0	0	0.12	0.37	0.09	0.22	0.31	0.29
56	0	0	0.10	0.28	0.08	0.18	0.25	0.22
58	0	0	0.09	0.17	0.08	0.16	0.18	0.15
60	0	0	0.08	0.06	0.10	0.14	0.09	0.07

Table 12 Insertion Loss for Acoustically Lined Round Ducts with 2 in. Lining

Diameter, in.	Insertion Loss, dB/ft Octave Midband Frequency, Hz							
	63	125	250	500	1000	2000	4000	8000
6	0.56	0.80	1.37	2.25	2.17	2.31	2.04	1.26
8	0.51	0.75	1.33	2.23	2.19	2.17	1.83	1.18
10	0.46	0.71	1.29	2.20	2.20	2.04	1.64	1.12
12	0.42	0.67	1.25	2.18	2.18	1.91	1.48	1.05
14	0.38	0.63	1.21	2.15	2.14	1.79	1.34	1.00
16	0.35	0.59	1.17	2.12	2.08	1.67	1.21	0.95
18	0.32	0.56	1.13	2.10	2.01	1.56	1.10	0.90
20	0.29	0.52	1.09	2.07	1.92	1.45	1.00	0.87
22	0.27	0.49	1.05	2.03	1.82	1.34	0.92	0.83
24	0.25	0.46	1.01	2.00	1.71	1.24	0.85	0.80
26	0.24	0.43	0.97	1.96	1.59	1.14	0.79	0.77
28	0.22	0.40	0.93	1.93	1.46	1.04	0.74	0.74
30	0.21	0.37	0.90	1.88	1.33	0.95	0.69	0.71
32	0.20	0.34	0.86	1.84	1.20	0.87	0.66	0.69
34	0.19	0.32	0.82	1.79	1.07	0.79	0.63	0.66
36	0.18	0.29	0.79	1.74	0.93	0.71	0.60	0.64
38	0.17	0.27	0.76	1.69	0.80	0.64	0.58	0.61
40	0.16	0.24	0.73	1.63	0.68	0.57	0.55	0.58
42	0.15	0.22	0.70	1.57	0.56	0.50	0.53	0.55
44	0.13	0.20	0.67	1.50	0.45	0.44	0.51	0.52
46	0.12	0.17	0.64	1.43	0.35	0.39	0.48	0.48
48	0.11	0.15	0.62	1.36	0.26	0.34	0.45	0.44
50	0.09	0.12	0.60	1.28	0.19	0.29	0.41	0.40
52	0.07	0.10	0.58	1.19	0.13	0.25	0.37	0.34
54	0.05	0.08	0.56	1.10	0.09	0.22	0.31	0.29
56	0.02	0.05	0.55	1.00	0.08	0.18	0.25	0.22
58	0	0.03	0.53	0.90	0.08	0.16	0.18	0.15
60	0	0	0.53	0.79	0.10	0.14	0.09	0.07

Table 13 Insertion Loss of Unlined and Lined Square Elbows Without Turning Vanes

	Insertion Loss, dB	
	Unlined Elbows	Lined Elbows
$fw < 1.9$	0	0
$1.9 \leq fw < 3.8$	1	1
$3.8 \leq fw < 7.5$	5	6
$7.5 \leq fw < 15$	8	11
$15 \leq fw < 30$	4	10
$fw > 30$	3	10

Note: f = center frequency, kHz, and w = width, in.

Table 14 Insertion Loss of Round Elbows

	Insertion Loss, dB
$fw < 1.9$	0
$1.9 \leq fw < 3.8$	1
$3.8 \leq fw < 7.5$	2
$fw > 7.5$	3

Note: f = center frequency, kHz, and w = width, in.

Table 15 Insertion Loss of Unlined and Lined Square Elbows with Turning Vanes

	Insertion Loss, dB	
	Unlined Elbows	Lined Elbows
$fw < 1.9$	0	0
$1.9 \leq fw < 3.8$	1	1
$3.8 \leq fw < 7.5$	4	4
$7.5 \leq fw < 15$	6	7
$fw > 15$	4	7

Note: f = center frequency, kHz, and w = width, in.

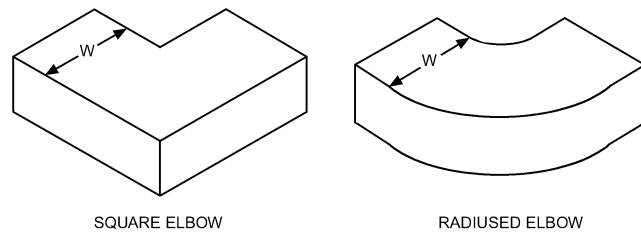

Fig. 17 Rectangular Duct Elbows

Duct Silencers

Silencers, sometimes called sound attenuators, sound traps, or mufflers, are elements designed to reduce the noise transmitted from a noise source to a receiver. For HVAC applications, the most common silencers are duct silencers, installed on the intake and/or discharge side of a fan or air handler. Also, they may be used on the receiver side of other noise generators like terminal boxes, valves, dampers, etc.

Duct silencers are available in varying shapes and sizes to fit project ductwork. Generally, a duct silencer's outer appearance is similar to a piece of ductwork. It consists of a sheet metal casing with length commonly ranging from 3 to 10 ft. Common shapes include rectangular, round, elbow, tee, and transitional. [Figure 18](#) shows some duct silencer configurations.

All silencers can be rated for (1) insertion loss, (2) dynamic insertion loss, (3) pressure drop, and (4) generated noise.

Insertion loss is the reduction in the sound power level at the receiver after the silencer is installed ("inserted") in the system. Insertion loss is measured as a function of frequency and commonly published in full octave bands ranging from 63 to 8000 Hz.

Table 16 Lined Flexible Duct Insertion Loss

Diameter, in.	Length, ft	Insertion Loss, dB						
		Octave Midband Frequency, Hz						
		63	125	250	500	1000	2000	4000
4	12	6	11	12	31	37	42	27
	9	5	8	9	23	28	32	20
	6	3	6	6	16	19	21	14
	3	2	3	3	8	9	11	7
5	12	7	12	14	32	38	41	26
	9	5	9	11	24	29	31	20
	6	4	6	7	16	19	21	13
	3	2	3	4	8	10	10	7
6	12	8	12	17	33	38	40	26
	9	6	9	13	25	29	30	20
	6	4	6	9	17	19	20	13
	3	2	3	4	8	10	10	7
7	12	9	12	19	33	37	38	25
	9	6	9	14	25	28	29	19
	6	4	6	10	17	19	19	13
	3	2	3	5	8	9	10	6
8	12	8	11	21	33	37	37	24
	9	6	8	16	25	28	28	18
	6	4	6	11	17	19	19	12
	3	2	3	5	8	9	9	6
9	12	8	11	22	33	37	36	22
	9	6	8	17	25	28	27	17
	6	4	6	11	17	19	18	11
	3	2	3	6	8	9	9	6
10	12	8	10	22	32	36	34	21
	9	6	8	17	24	27	26	16
	6	4	5	11	16	18	17	11
	3	2	3	6	8	9	9	5
12	12	7	9	20	30	34	31	18
	9	5	7	15	23	26	23	14
	6	3	5	10	15	17	16	9
	3	2	2	5	8	9	8	5
14	12	5	7	16	27	31	27	14
	9	4	5	12	20	23	20	11
	6	3	4	8	14	16	14	7
	3	1	2	4	7	8	7	4
16	12	2	4	9	23	28	23	9
	9	2	3	7	17	21	17	7
	6	1	2	5	12	14	12	5
	3	1	1	2	6	7	6	2

Note: The 63 Hz insertion loss values are estimated from higher-frequency insertion loss values.

Dynamic insertion loss is insertion loss at a given airflow direction and velocity. The insertion loss of a silencer varies depending on whether the sound is traveling in the same or opposite direction as the airflow. Silencer performance changes with absolute duct velocity. However, airflow velocity generally does not significantly affect silencers operating at a pressure drop of 0.35 in. of water or less, including system effects.

Pressure drop is measured across the silencer at a given velocity. Good flow conditions are required at both the inlet and discharge of the silencer. The measuring points are usually 2.5 to 5 duct diameters upstream and downstream of the silencer to avoid turbulent flow areas near the silencer and to allow for any static pressure regain.

Airflow-generated noise is the sound power generated by the silencer when quiet air flows through it. A silencer's generated noise is a function of frequency and is referenced to specific velocities and airflow direction (forward or reverse). The airflow-generated sound power of the silencer is logarithmically proportional to silencer

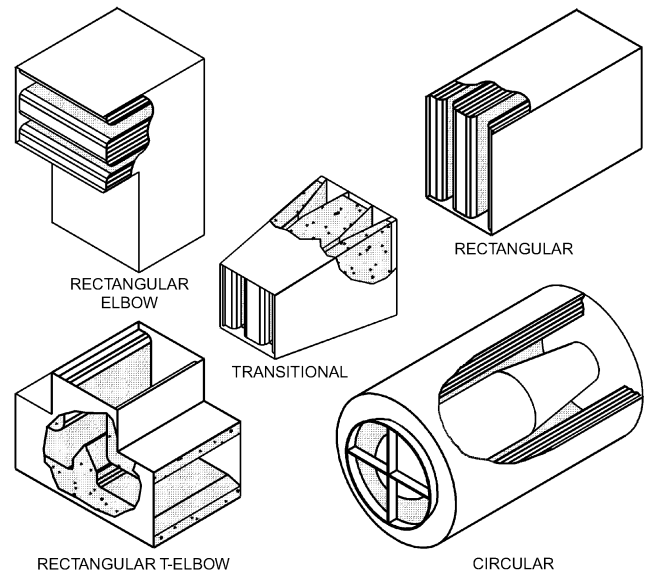

Fig. 18 Duct Silencer Configurations

cross-sectional area. A silencer of twice the cross-sectional area generally has double the sound power (3 dB more generated noise).

There are three types of HVAC duct silencers: dissipative (with acoustic media), reactive (no media), and active silencers.

Dissipative Silencers. Dissipative silencers use sound-absorptive media such as fiberglass as the primary means of attenuating sound; mineral wool can be used in high-temperature applications but may contain too much contamination ("shot") for commercial HVAC applications. Usually the absorptive media is covered by perforated metal to protect it from erosion by airflow. If internal silencer velocities are high (faster than 4500 fpm), media erosion may be further reduced by a layer of material such as fiberglass cloth or film liner placed between the absorptive media and the perforated metal (note that film liner has not been rated according to NFPA [National Fire Protection Association] standards). The thicker and more rigid the protective material, the more it will degrade the insertion loss performance of the silencer. Special methods of applying the material may be used to reduce, but not eliminate, the degradation.

Dissipative silencer performance is primarily a function of silencer length; airflow constriction; number, thickness, and shape of splitters or centerbodies; and type and density of absorptive media. The absorptive media allows dissipative silencers to provide significant insertion loss performance over a wide frequency range.

Insertion loss performance does not necessarily increase linearly with silencer length; for a given length, silencer designs can produce varying insertion loss and pressure drop data. Even at the same pressure drop and length, silencers can be configured to provide varying insertion loss performance across the frequency spectrum.

Reactive Silencers. Reactive silencers are constructed only of metal, both solid and perforated, with chambers of specially designed shapes and sizes behind the perforated metal that are tuned as resonators to react with and reduce sound power at certain frequencies. The outward appearance of reactive silencers is similar to that of their dissipative counterparts. However, because of tuning, insertion loss over a wide frequency range is more difficult to achieve. Longer lengths may be required to achieve similar insertion loss performance as dissipative silencers. Airflow generally increases the insertion loss of reactive silencers.

Figure 19 compares the insertion loss of dissipative silencers, with and without protective materials, against that of a reactive silencer for the same pressure drop.

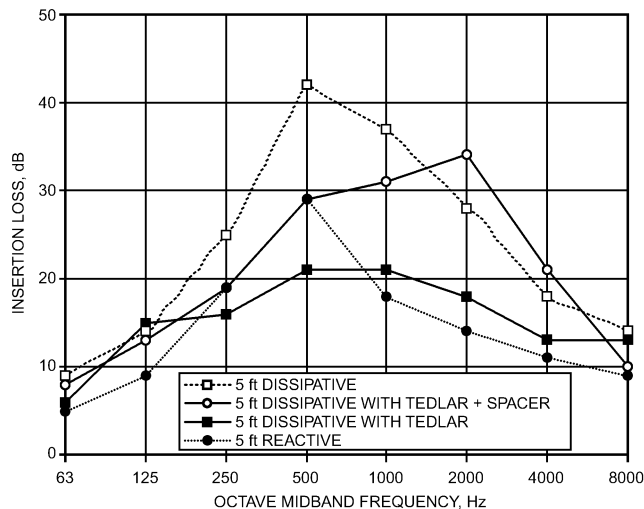

Fig. 19 Comparison of 5 ft Long Dissipative and Reactive Silencer Performance

Active Silencers. Active duct silencers, sometimes called noise canceling systems, produce inverse sound waves that cancel noise primarily at low frequencies. An input microphone measures noise in the duct and converts it to electrical signals, which are processed by a digital computer to generate opposite, “mirror-image” sound signals of equal amplitude. A secondary noise source destructively interferes with the primary noise and cancels a significant portion of it. An error microphone measures residual sound beyond the silencer and provides feedback to adjust the computer model for improved performance.

Because components are mounted outside the airflow, there is no pressure loss or airflow-generated noise. Performance is limited, however, if excessive turbulence is detected by the microphones. Manufacturers recommend using active silencers where duct velocities are less than 1500 fpm and where duct configurations are conducive to smooth, evenly distributed airflow. If noise levels increase, an active silencer then increases the insertion loss to compensate for the increased source noise.

Active silencers have significant low-frequency insertion loss but little mid- and high-frequency insertion loss. If required, combinations of active (for the low-frequency components) and passive (for the mid- and high-frequency components) can be used to achieve insertion loss over a wide frequency range.

Test Standard. Data for dissipative and reactive silencers should be obtained from tests consistent with the procedures outlined in the most current version of ASTM *Standard E477*. (This standard has not been verified for determining performance of active silencers.) Because insertion loss measurements use a substitution technique, reasonable (± 3 dB) insertion loss values can be achieved down to 63 Hz. Airflow-generated noise, however, cannot be measured accurately below 100 Hz because of the lack of a standardized means of qualifying the reverberant rooms for sound power measurements at lower frequencies (a function of room size). Round robin tests performed at several manufacturers’ and independent testing laboratories showed that airflow-generated sound power data has an expected standard deviation of ± 3 to 6 dB over the octave band frequency range of 125 to 8000 Hz.

Silencer Selection Issues. When selecting a duct silencer, consider the following:

- Insertion loss required to achieve required room sound criteria
- Allowable pressure drop (if no specific requirement, then keep under 0.35 in. of water, including system effects; when system

Table 17 Approximate Silencer System Effect Factors

Silencer Condition	Pressure Drop Factor*
Inlet (within 3 to 4 duct diameters)	
Straight unobstructed duct	1.0
Free air/plenum with smooth inlet	1.05
Radius elbow (with turning vanes)	1.05
Radius elbow (no turning vanes)	1.1
Miter elbow	1.3
Free air/plenum with sharp inlet	1.1 to 1.30
Fan	1.1 to 1.3
Outlet (within 3 to 4 duct diameters)	
Straight unobstructed duct	1.0
Duct doubles area abruptly	1.4
Radius elbow (with turning vanes)	1.5
Radius elbow (no turning vanes)	1.9
Miter elbow	2.0
Abrupt expansion/plenum	2.0
Fan	1.2 to 1.4

*Silencer pressure drop (including system effects) = silencer pressure drop per test code \times pressure drop factor (inlet) \times pressure drop factor (outlet).

effects are unknown, keep under 0.20 in. of water, excluding system effects) at system duct velocity

- Available space
- Amount of airflow-generated noise that can be tolerated

Insertion Loss Issues. To determine the insertion loss required, analyze the duct system, summing noise-generating mechanisms and subtracting attenuation elements (not including the silencer). The silencer’s required insertion loss is the amount by which the estimated resultant sound pressure level in the space exceeds the room criteria for the space. The user should consider both the sound path through the ductwork and outlets as well as potential locations where sound may break out of the ductwork.

Pressure Drop Issues. Care should be taken in applying test data to actual project installations. Adverse aerodynamic system effects can significantly impact silencer performance. That is, if the silencer is located where less-than-ideal conditions exist in the inlet and/or the discharge of the silencer (3 to 5 duct diameters of straight duct), then the silencer’s effective pressure drop (PD) is increased (total silencer PD = silencer PD per ASTM E477 + system effect losses). In some situations, the added system effect losses can be greater than the silencer’s pressure drop. Some manufacturers give guidelines for estimated pressure loss increases due to varying silencer inlet and discharge configurations (Table 17); these should be considered as general guidelines. Substantial variations can occur depending on the type of silencer, its internal geometry, size of silencer, size of duct, airflow turbulence, etc. For example, an elbow fitting located immediately following a silencer prevents regain of the silencer’s leaving velocity pressure. In addition, local velocities in the elbow fitting are greater than the average duct velocity that produces higher overall static pressure losses.

Silencer Location. Silencers should generally be located as close to the noise source as possible but far enough away to allow a uniform flow profile to develop. This helps contain noise at the source and limits potential points where unsilenced noise may break out. However, because turbulent airflow usually exists close to noise sources such as fans, valves, dampers, etc., the user should carefully evaluate aerodynamic system effects.

A straight silencer has a lower first cost than a transitional or elbow silencer. If space limitations prohibit the effective use of a straight silencer, or if the pressure drop (including system effects) is greater than the loss allowed, the use of elbow or transitional silencers should be evaluated. Special fan inlet and discharge silencers, including cone silencers and inlet box silencers, minimize aerodynamic system effects, and contain noise at the source.

Table 18 Duct Branch Sound Power Division

$S_{Bi}/\sum S_{Bi}$	ΔL_{Bi}	$S_{Bi}/\sum S_{Bi}$	ΔL_{Bi}
1.00	0	0.10	10
0.80	1	0.08	11
0.63	2	0.063	12
0.50	3	0.050	13
0.40	4	0.040	14
0.32	5	0.032	15
0.25	6	0.025	16
0.20	7	0.020	17
0.16	8	0.016	18
0.12	9	0.012	19

Airflow-Generated Noise Issues. In most installations, airflow-generated noise is much less than, and does not contribute to, the reduced noise level on the quiet side of the silencer. This is especially true if the silencer is properly located close to the source. In general, airflow-generated noise should be evaluated if pressure drops exceed 0.35 in. of water (including system effects), the noise criterion is below RC 35, or if the silencer is located very close to or in the occupied space.

To evaluate airflow-generated noise, sum the noise-generating mechanisms (from the noise source to the silencer) and subtract the attenuation elements (including the silencer) in the order they occur to determine the resultant sound power level on the quiet side of the silencer. This resultant level must be summed logarithmically with the silencer’s generated noise (referenced to actual duct velocities, inlet and discharge configurations, and cross-sectional area). If the generated noise is more than 10 dB below the residual sound, then the silencer’s generated noise will have no impact on system noise levels.

Duct Branch Sound Power Division

When sound traveling in a duct encounters a junction, the sound power contained in the incident sound waves in the main feeder duct is distributed between the branches associated with the junction (Ver 1982, 1984a). This division of sound power is called branch sound power division. The corresponding attenuation of sound power transmitted down each branch of the junction is comprised of two components. The first is associated with reflection of the incident sound wave if the sum of the cross-sectional areas of individual branches $\sum S_{Bi}$ differs from the cross-sectional area of the main feeder duct. The second and more dominant component is associated with energy division according to the ratio of the cross-sectional area of an individual branch S_{Bi} divided by $\sum S_{Bi}$. Values for the attenuation of sound power ΔL_{Bi} are given in [Table 18](#).

Duct End Reflection Loss

When low-frequency plane sound waves interact with an opening that discharges into a large room, a significant amount of the sound energy incident on this interface is reflected back into the duct. The sound attenuation values ΔL associated with duct end reflection losses for a duct that terminates in free space are given in [Table 19](#).

[Table 20](#) lists values for ducts that terminate flush with a wall (AMCA *Standard* 300; Sandbakken et al. 1981). Diffusers that terminate in a suspended lay-in acoustic ceiling can be treated as terminating in free space. To use [Table 19](#), if the duct terminating into a diffuser is rectangular, the duct diameter D is given by

$$D = \sqrt{4A/\pi} \tag{6}$$

where A = area (in²) of the rectangular duct.

Table 19 Duct End Reflection Loss—Duct Terminated in Free Space

Duct Diameter, in.	End Reflection Loss, dB					
	Octave Midband Frequency, Hz					
	63	125	250	500	1000	2000
6	20	14	9	5	2	1
8	18	12	7	3	1	0
10	16	11	6	2	1	0
12	14	9	5	2	1	0
16	12	7	3	1	0	0
20	10	6	2	1	0	0
24	9	5	2	1	0	0
28	8	4	1	0	0	0
32	7	3	1	0	0	0
36	6	3	1	0	0	0
48	5	2	1	0	0	0
72	3	1	0	0	0	0

Table 20 Duct End Reflection Loss—Duct Terminated Flush with Wall

Duct Diameter, in.	End Reflection Loss, dB				
	Octave Midband Frequency, Hz				
	63	125	250	500	1000
6	18	13	8	4	1
8	16	11	6	2	1
10	14	9	5	2	1
12	13	8	4	1	0
16	10	6	2	1	0
20	9	5	2	1	0
24	8	4	1	0	0
28	7	3	1	0	0
32	6	2	1	0	0
36	5	2	1	0	0
48	4	1	0	0	0
72	2	1	0	0	0

There are some limitations associated with [Tables 19](#) and [20](#). The tests on which these tables are based were conducted with straight sections of round ducts. These ducts directly terminated into a reverberation chamber with no restriction on the end of the duct or with a round orifice placed over the end of the duct. Diffusers, round or rectangular, usually have a restriction associated with them, either a damper, airflow guide vanes, a perforated metal facing, or a combination of these elements. Currently, there are no data on the effects of these elements. It is not known whether these elements react similarly to the orifices used in tests. As a result, the effects of an orifice placed over the end of a duct are not included in [Tables 19](#) and [20](#). Using Equation (6) to calculate D should yield reasonable results for diffusers with low aspect ratios (length/width). However, many types of diffusers (particularly slot diffusers) have high aspect ratios. It is not known whether [Tables 19](#) and [20](#) can be accurately used with these diffusers. Finally, many diffusers do not have long straight sections (greater than three duct diameters) before they terminate into a room. Many duct sections between a main feed branch and a diffuser may be curved or short. The effects of these configurations on duct end reflection loss are not known. [Tables 19](#) and [20](#) can be used with reasonable accuracy for many diffuser configurations. However, caution should be exercised when a diffuser configuration differs from the test conditions used to derive these tables.

Health Effects of Fiberglass Products in HVAC Systems

Fiberglass duct liner continues to be a cost-effective solution to noise control in most HVAC duct systems. However, fiberglass has been banned from or severely limited for use in some institutional, educational, and medical projects. The decisions are based on concerns that the fibers may be carcinogenic and these products may promote microbial growth.

However, a review published in ASHRAE (1993) found no clear evidence that any form of manufactured mineral fibers is carcinogenic. The International Agency for Research on Cancer (IARC) has performed research in regard to the carcinogenicity of fiberglass materials and found inadequate evidence to link inhalation of fiberglass wool with cancer in humans (WHO 1986). IARC did indicate there is a possible linkage to cancer from glass wool based on heavy-dosage direct injection into animals. As a result of this, the U.S. Department of Health & Human Services (USDHHS) added glass wool to its list of substances “reasonably anticipated” to be a carcinogen. Environment Canada (1994) stated that studies have failed to show any evidence that fiberglass is carcinogenic and classified the material as “unlikely to be carcinogenic to humans.” In addition, the report indicated fiberglass is not entering the environment in quantities or conditions that may constitute a danger to human life or health.

Morey and Williams (1991) found that both moisture and dirt are required for microbial growth and that microbial growth can occur on any surface including sheet metal, sound traps, filters, and turning vanes, in addition to duct lining. Microbial growth is not related to only one component. Thus, removal of fiberglass duct lining by itself does not eliminate microbial growth. Control of moisture and dirt in duct systems is the best method of reducing potential microbial growth. Duct design for access, proper filtration, humidification, and condensate systems; methods to prevent moisture and dirt accumulation during installation and commissioning; and regular maintenance procedures can reduce the occurrence of microbial growth (ASHRAE *Standard* 62-1999). More information on health aspects and the proper use of fiberglass in HVAC systems is available from the North American Insulation Manufacturers Association (NAIMA).

Owners and designers should understand the acoustical impact of removing or disallowing fiberglass duct lining from any building. Compensating for removal of fiberglass duct liner may require larger and longer duct runs, larger fans and fan plenums, and the use of alternative noise control devices such as removable lined duct sections, foil-coated liner, no-fill sound traps, and active noise control, which may be less effective and more expensive.

Certain spaces in health care facilities such as operating rooms and critical care spaces should follow duct liner guidelines issued by the American Institute of Architects Committee on Architecture (AIA 2001). The complete removal of fiberglass duct liner from duct systems in spaces such as theaters, concert halls, recording and TV studios, and educational facilities could result in poor acoustical qualities and may render the spaces unusable.

SOUND RADIATION THROUGH DUCT WALLS

Airflow-Generated Duct Rumble

“Duct rumble” is low-frequency sound generated by vibration of a flat duct surface. The vibration is caused when a HVAC fan and its connected ductwork act as a semiclosed, compressible-fluid pumping system; both acoustic and aerodynamic air pressure fluctuations at the fan are transmitted to other locations in the duct system. Duct rumble occurs at the resonance frequencies of the duct (Ebbing et al. 1978), and duct rumble levels of 65 to 95 dB in the 16 to 100 Hz frequency range have been measured in occupied spaces. With belt-

driven fans, the rumble sound level fluctuates above and below the mean dB level by 5 to 25 dB at a rate of 2 to 10 “beats” per second (Blazier 1993). The most common beat frequency occurs at the difference between the fan rpm and twice the belt frequency (belt rpm = fan sheave diameter × sheave rpm × π /belt length). As shown in [Figure 20](#), duct rumble is dependent on the level of duct vibration. The very low resonant frequencies at which duct rumble occurs means that the sound wavelengths are very long (10 to 70 ft), and the rumble can exert the sound energy over long distances. Lightweight architectural structures such as metal frame and drywall systems near a source of duct rumble can easily vibrate and “rattle” in sympathy to the rumble sound.

Case histories of duct rumble indicate that duct vibration is much more prevalent when there is a dramatic change in airflow direction near the fan, and at large, flat, unreinforced duct surfaces (usually greater than 48 in. in any dimension) near the fan. Problems can occur with dimensions as small as 18 in. if high noise levels are present. [Figure 21](#) shows duct configurations near a centrifugal fan. Good to optimum designs of fan discharge transitions minimize potential for duct rumble; however, this may not completely eliminate the potential for duct rumble, which also depends heavily on flow turbulence at the fan wheel, duct stiffness, and duct resonant characteristics.

Ductliner, sound attenuators, and duct lagging with mass-loaded vinyl over fiberglass do not reduce duct rumble. However, several of the following methods have been used to eliminate or reduce duct rumble. One method is to alter the fan or motor speed, which changes the frequency of air pressure fluctuations so that they differ from duct wall resonance frequencies. Another method is to apply rigid materials, such as duct reinforcements and drywall, directly to the duct wall to change the wall resonance frequencies ([Figure 22](#)). Noise reductions of 5 to 11 dB in the 31.5 and 63 Hz octave frequency bands are possible using this treatment.

Mass-loaded materials applied in combination with absorptive materials do not alleviate duct rumble noise unless both materials are completely decoupled from the duct by a large air separation (preferably greater than 6 in.). The mass-loaded material should have a surface density greater than 4 lb/ft². An example of this type of construction, using two layers of drywall, is shown in [Figure 23](#). Because the treatment is decoupled from the duct wall, it provides the greatest noise reduction. Mass-loaded/absorptive material directly attached to a round duct can be an effective noise control treatment for high-frequency noise above the duct rumble frequency range of 16 to 100 Hz. In addition, the stiffness of round ductwork prevents flexure of the duct wall. Where space allows, round ductwork is an effective method to prevent duct rumble (Harold 1986). However, unless round ducts are used throughout the primary duct system, duct rumble can be still generated at a remote point where round duct is converted to rectangular or flat oval.

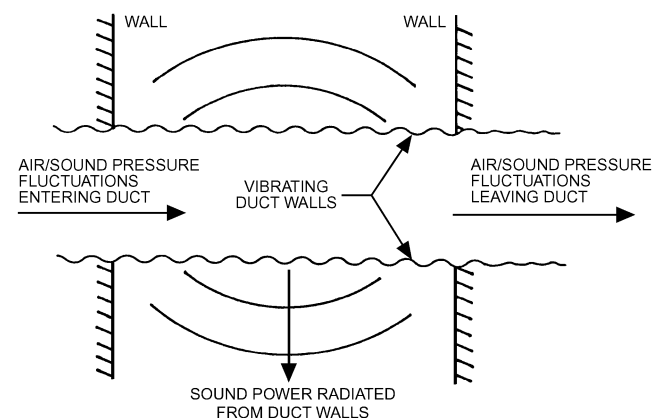

Fig. 20 Airflow-Generated Duct Rumble

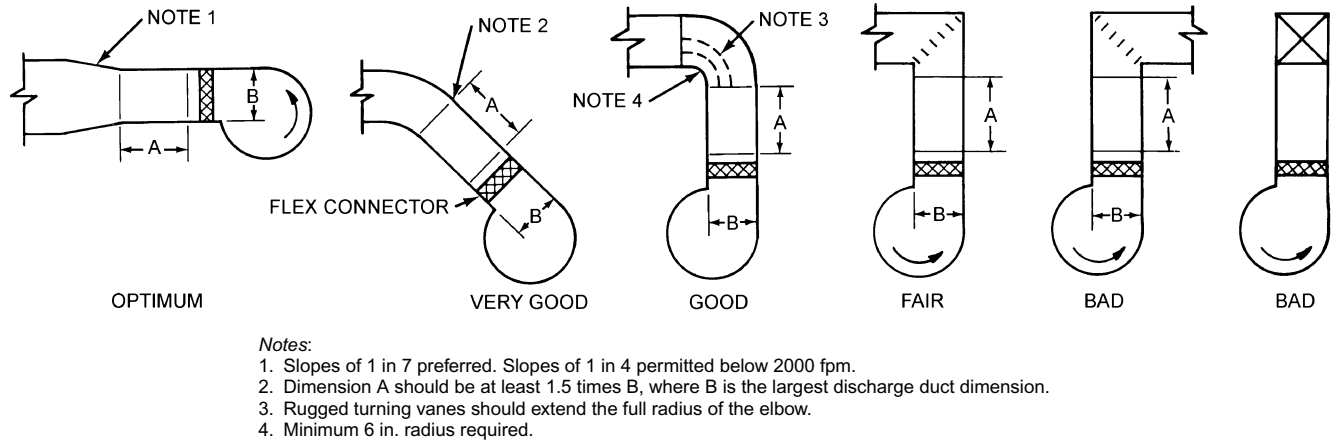

Fig. 21 Various Outlet Configurations for Centrifugal Fans and Their Possible Rumble Conditions

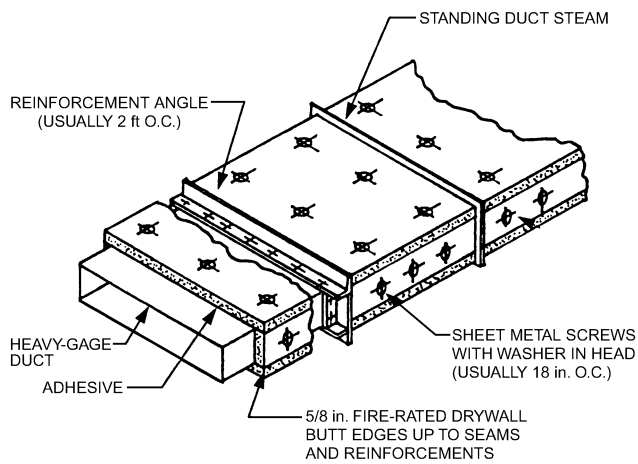

Fig. 22 Drywall Lagging for Duct Rumble

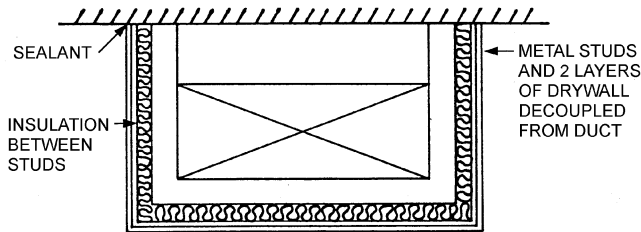

Fig. 23 Decoupled Drywall Enclosure for Duct Rumble

Round ducts can have a resonant “ring frequency,” which is dependent on duct material and diameter. On rare occasions, loud in-duct noise, such as blade-pass frequency noise from a centrifugal or axial fan, can excite this resonance. In these instances, a sound attenuator should be located as close to the fan as possible.

Sound Breakout and Break-In from Ducts

Breakout is sound associated with fan or airflow noise inside a duct that radiates through duct walls into the surrounding area (Figure 24). Breakout can be a problem if it is not adequately attenuated before the duct runs over an occupied space (Cummings 1983; Lilly 1987). Sound that is transmitted into a duct from the surrounding area is called **break-in** (Figure 25). The main factors affecting

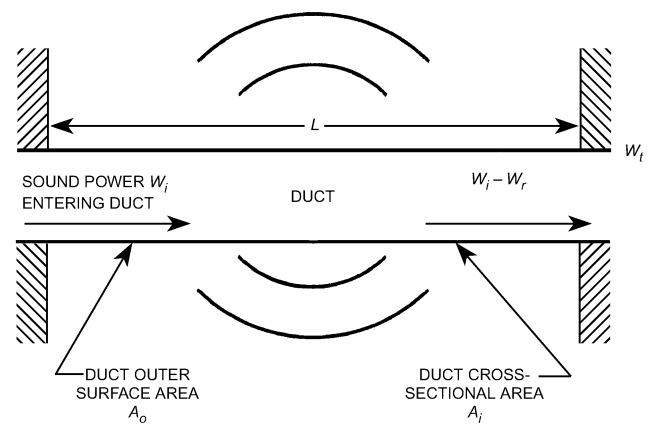

Fig. 24 Breakout Noise

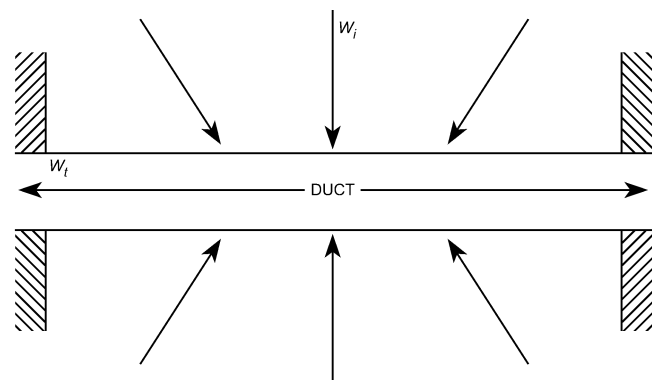

Fig. 25 Break-In Noise

breakout and break-in sound transmission are the transmission loss of the duct, the total exposed surface area of the duct, and the presence of any acoustical duct liner.

Transmission loss (TL) is the ratio of sound power incident on a partition to the sound power transmitted through a partition. This ratio varies with acoustic frequency as well as duct shape, size, and wall thickness. Higher values of transmission loss result in less noise passing through the duct wall.

Breakout Sound Transmission from Ducts. The sound power level of sound that is transmitted through a duct wall and then radiated from the exterior surface of the duct wall is given by

$$L_{w(out)} = L_{w(in)} + 10 \log\left(\frac{S}{A}\right) - TL_{out} \quad (7)$$

where

- $L_{w(out)}$ = sound power level of sound radiated from outside surface of duct walls, dB
- $L_{w(in)}$ = sound power level of sound inside duct, dB
- S = surface area of outside sound-radiating surface of duct, in²

Table 21 TL_{out} Versus Frequency for Rectangular Ducts

Duct Size, in. × in.	Gage	TL_{out} , dB							
		Octave Midband Frequency, Hz							
		63	125	250	500	1000	2000	4000	8000
12 × 12	24	21	24	27	30	33	36	41	45
12 × 24	24	19	22	25	28	31	35	41	45
12 × 48	22	19	22	25	28	31	37	43	45
24 × 24	22	20	23	26	29	32	37	43	45
24 × 48	20	20	23	26	29	31	39	45	45
48 × 48	18	21	24	27	30	35	41	45	45
48 × 96	18	19	22	25	29	35	41	45	45

Note: Data are for duct lengths of 20 ft, but values may be used for cross section shown regardless of length.

Table 22 Experimentally Measured TL_{out} Versus Frequency for Round Ducts

Diameter, in.	Length, ft	Gage	TL_{out} , dB						
			Octave Midband Frequency, Hz						
			63	125	250	500	1000	2000	4000
Long Seam Ducts									
8	15	26	>45	(53)	55	52	44	35	34
14	15	24	>50	60	54	36	34	31	25
22	15	22	>47	53	37	33	33	27	25
32	15	22	(51)	46	26	26	24	22	38
Spiral Wound Ducts									
8	10	26	>48	>64	>75	72	56	56	46
12	12	26*	52	51	53	51	50	46	36
14	10	26	>43	>53	55	33	34	35	25
24	24	24	51	53	51	44	36	26	29
	24	24*	51	51	54	44	39	33	47
26	10	24	>45	50	26	26	25	22	36
	10	16	>48	53	36	32	32	28	41
32	10	22	>43	42	28	25	26	24	40
36	24	20	51	51	52	46	36	32	55

*Ducts internally lined with 1 in. thick 1.5 pcf fiberglass with 24 ga perforated sheet metal inner liner.

Note: In cases where background sound swamped the sound radiated from duct walls, a lower limit on TL is indicated by >. Parentheses indicate measurements in which background sound has produced greater uncertainty than usual in data.

Table 23 TL_{out} Versus Frequency for Flat Oval Ducts

Duct Size, in. × in.	Gage	TL_{out} , dB						
		Octave Midband Frequency, Hz						
		63	125	250	500	1000	2000	4000
12 × 6	24	31	34	37	40	43	—	—
24 × 6	24	24	27	30	33	36	—	—
24 × 12	24	28	31	34	37	—	—	—
48 × 12	22	23	26	29	32	—	—	—
48 × 24	22	27	30	33	—	—	—	—
96 × 24	20	22	25	28	—	—	—	—
96 × 48	18	28	31	—	—	—	—	—

Note: Data are for duct lengths of 20 ft, but values may be used for cross section shown regardless of length.

- A = cross-section area of inside of duct, in²
- TL_{out} = normalized duct breakout transmission loss (independent of S and A), dB

Values of TL_{out} for rectangular ducts are given in Table 21, for round ducts are given in Table 22, and for flat oval ducts are given in Table 23 (Cummings 1983, 1985; Lilly 1987).

The equations for S and A for rectangular ducts are

$$S = 2 \times 12L(a + b) \quad (8)$$

$$A = ab \quad (9)$$

where

- a = larger duct cross-section dimension, in.
- b = smaller duct cross-section dimension, in.
- L = length of duct sound-radiating surface, ft

The equations for S and A for round ducts are

$$S = 12L\pi d \quad (10)$$

$$A = \pi \frac{d^2}{4} \quad (11)$$

where

- d = duct diameter, in.
- L = length of duct sound-radiating surface, ft

The equations for S and A for flat oval ducts are

$$S = 12L[2(a - b) + \pi b] \quad (12)$$

$$A = b(a - b) + \frac{\pi b^2}{4} \quad (13)$$

where

- a = length of major axis, in.
- b = length of minor axis, in.
- L = length of duct sound-radiating surface, ft

Equation (7) assumes that there is no decrease in the internal sound power level with distance along the length of the duct. Thus, it is valid only for relatively short lengths of unlined duct. For long ducts or ducts that have internal acoustic lining, one approach is to divide the duct into sections, each of which is short enough to be modeled as a section of duct with constant internal sound power level over the length of each section. The recommended maximum length of each section is the length that would result in a 1 dB reduction in the internal sound power level at the frequency of interest. Alternatively, the total sound power radiated from any duct of any length (including an internally lined duct) can be calculated in a single step with a modified version of Equation (7) (Lilly 1987):

$$L_{w(out)} = L_{w(in)} + 10 \log\left(\frac{S^*}{A}\right) - TL_{out} \quad (14)$$

where S^* is the effective surface area of the duct. $S^* = PL^*$, where P = duct perimeter, and L^* = effective length. The effective length L^* is calculated as

$$L^* = \frac{\gamma^L - 1}{\ln \gamma} \quad (15)$$

where

$$\gamma = 10^{\left(\frac{-\alpha}{10}\right)} \quad (16)$$

where α = duct attenuation rate, dB/ft.

In most rooms where the listener is close to the duct, an estimate of the breakout sound pressure level can be obtained from

$$L_p = L_{w(out)} - 10 \log[\pi r L] + 10 \tag{17}$$

where

- L_p = sound pressure level at a specified point in the space, dB
- $L_{w(out)}$ = sound power level of sound radiated from outside surface of duct walls, given by Equation (7), dB
- R = distance between duct and position for which L_p is calculated, ft
- L = length of the duct sound-radiating surface, ft

Example 3. A 24 in. by 24 in. by 25 ft long rectangular supply duct is constructed of 22 ga sheet metal. Given the following sound power levels in the duct, what are the breakout sound pressure levels 5 ft from the surface of the duct?

Solution:

Using Equations (7) and (17) yields

	Octave Midband Frequency, Hz						
	63	125	250	500	1000	2000	4000
$L_{w(in)}$	90	85	80	75	70	65	60
$-TL_{out}$ (Table 20)	-19	-22	-25	-28	-31	-37	-43
$10 \log(S/A)$	17	17	17	17	17	17	17
$L_{w(out)}$	88	80	72	64	56	45	34
$-10 \log(\pi r L) + 10$	-16	-16	-16	-16	-16	-16	-16
L_p , dB	72	64	56	48	40	29	18

Using Equations (14) and (17) yields

	Octave Midband Frequency, Hz						
	63	125	250	500	1000	2000	4000
$L_{w(in)}$	90	85	80	75	70	65	60
$-TL_{out}$ (Table 20)	-19	-22	-25	-28	-31	-37	-43
α , dB/ft	0.4	0.2	0.1	0.05	0.05	0.05	0.05
γ	0.91	0.95	0.98	0.99	0.99	0.99	0.99
L^* , ft	10	15	19	22	22	22	22
$10 \log(S^*/A)$	13	15	16	16	16	16	16
$L_{w(out)}$	84	78	71	63	55	44	33
$-10 \log(\pi r L) + 10$	-16	-16	-16	-16	-16	-16	-16
L_p , dB	68	62	55	47	39	28	17

Example 4. Repeat Example 3, but with 2 in. thick internal duct liner.

Solution:

Using Equations (7) and (17),

	Octave Midband Frequency, Hz						
	63	125	250	500	1000	2000	4000
$L_{w(in)}$	90	85	80	75	70	65	60
$-TL_{out}$ (Table 20)	-19	-22	-25	-28	-31	-37	-43
$10 \log(S/A)$	17	17	17	17	17	17	17
$L_{w(out)}$	88	80	72	64	56	45	34
$-10 \log(\pi r L) + 10$	-16	-16	-16	-16	-16	-16	-16
L_p , dB	72	64	56	48	40	29	18

Solution:

Using Equations (14) and (17),

	Octave Midband Frequency, Hz						
	63	125	250	500	1000	2000	4000
$L_{w(in)}$	90	85	80	75	70	65	60
$-TL_{out}$ (Table 20)	-19	-22	-25	-28	-31	-37	-43
α , dB/ft	0.15	0.3	0.9	2.5	3.5	2.2	1.8
γ	0.97	0.93	0.81	0.56	0.45	0.60	0.66
L^* , ft	172	12	5	2	1	2	2
$10 \log(S^*/A)$	15	14	10	5	4	6	7
$L_{w(out)}$	86	77	65	52	43	34	24
$-10 \log(\pi r L) + 10$	-16	-16	-16	-16	-16	-16	-16
L_p , dB	70	61	49	36	27	18	8

Example 5. Repeat Example 4 using 24 in. diameter spiral round duct, 22 ga, 25 ft long with 1 in. thick acoustical duct lining.

Solution:

Using Equations (7) and (17),

	Octave Midband Frequency, Hz						
	63	125	250	500	1000	2000	4000
$L_{w(in)}$	90	85	80	75	70	65	60
$-TL_{out}$ (Table 21)	-51	-51	-54	-44	-39	-33	-47
$10 \log(S/A)$	17	17	17	17	17	17	17
$L_{w(out)}$	56	51	43	48	48	49	30
$-10 \log(\pi r L) + 10$	-16	-16	-16	-16	-16	-16	-16
L_p , dB	40	35	27	32	32	33	14

Using Equations (14) and (17),

	Octave Midband Frequency, Hz						
	63	125	250	500	1000	2000	4000
$L_{w(in)}$	90	85	80	75	70	65	60
$-TL_{out}$ (Table 21)	-51	-51	-54	-44	-39	-33	-47
α , dB/ft	0.25	0.46	1.01	2.0	1.71	1.24	0.85
γ	0.94	0.90	0.79	0.63	0.67	0.75	0.82
L^* , ft	13	9	4	2	3	3	5
$10 \log(S^*/A)$	14	12	9	6	7	8	10
$L_{w(out)}$	53	46	35	37	38	40	23
$-10 \log(\pi r L) + 10$	-16	-16	-16	-16	-16	-16	-16
L_p , dB	37	31	19	21	22	25	7

Using round duct eliminates the low-frequency rumble present with rectangular ducts but introduces some mid-frequency and high-frequency noise that can be reduced by adding duct liner as shown. The spectra associated with these examples are shown in Figures 26 and 27.

When sound is not transmitted through the wall of a round duct, it is transmitted down the duct and may become a problem at another point in the duct system. Flexible and rigid fiberglass ducts often come in round configurations. These types of round ducts do not have high transmission loss properties because they lack the mass or stiffness associated with round sheet metal ducts. Whenever duct sound breakout is a concern, fiberglass or flexible round duct should not be used.

Because Equation (7) does not take into consideration the reduction of sound power over the length of the duct, it will always overestimate the true breakout noise. The overestimation is insignificant for short sections of unlined ductwork, but can become very significant when the duct is long and has a high rate of attenuation. If the duct is long enough, Equation (7) can yield radiated sound power levels that are higher than the input sound power levels. This is clearly a false result, but it can be avoided by using Equation (14), which provides accurate results for any duct size and length.

Table 24 gives estimates of attenuation of different ceiling construction by octave band. The data can be used to estimate the noise reduction due to ceilings between ductwork and the receiver.

Break-In Sound Transmission into Ducts. The sound power level associated with sound transmitted into a duct through the duct walls from the space outside the duct is given by

$$L_{w(in)} = L_{w(out)} - TL_{in} - 3 \tag{18}$$

where

- $L_{w(in)}$ = sound power level of sound transmitted into duct and then transmitted upstream or downstream of point of entry, dB
- $L_{w(out)}$ = sound power level of sound incident on outside of duct walls, dB
- TL_{in} = duct break-in transmission loss, dB

Table 24 Ceiling/Plenum/Room Attenuations in dB for Generic Ceiling in T-Bar Suspension Systems

Tile Type	Approximate Density, lb/ft ²	Tile Thickness, in.	Octave Midband Frequency, Hz						
			63	125	250	500	1000	2000	4000
Mineral fiber	1.0	5/8	13	16	18	20	26	31	36
	0.5	5/8	13	15	17	19	25	30	33
Glass fiber	0.1	5/8	13	16	15	17	17	18	19
	0.6	2	14	17	18	21	25	29	35
Glass fiber with TL backing	0.6	2	14	17	18	22	27	32	39
Gypsum board tiles	1.8	1/2	14	16	18	18	21	22	22
Solid gypsum board ceiling	1.8	1/2	18	21	25	25	27	27	28
	2.3	5/8	20	23	27	27	29	29	30
Double layer of gypsum board	3.7	1	24	27	31	31	33	33	34
	4.5	1 1/4	26	29	33	33	35	35	36
Mineral fiber tiles, concealed spline mount.	0.5 to 1	5/8	20	23	21	24	29	33	34

Source: Warnock (1998)

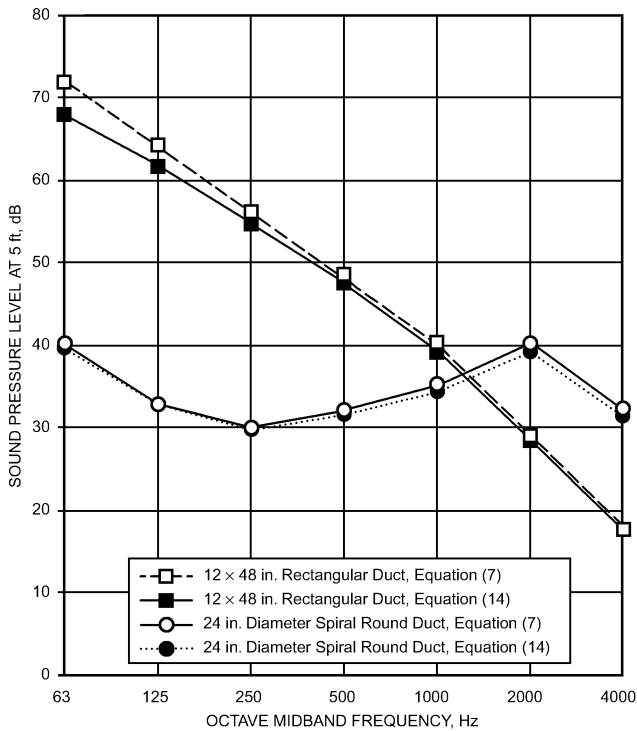

Fig. 26 Plotted Examples of Breakout Noise from Unlined Duct

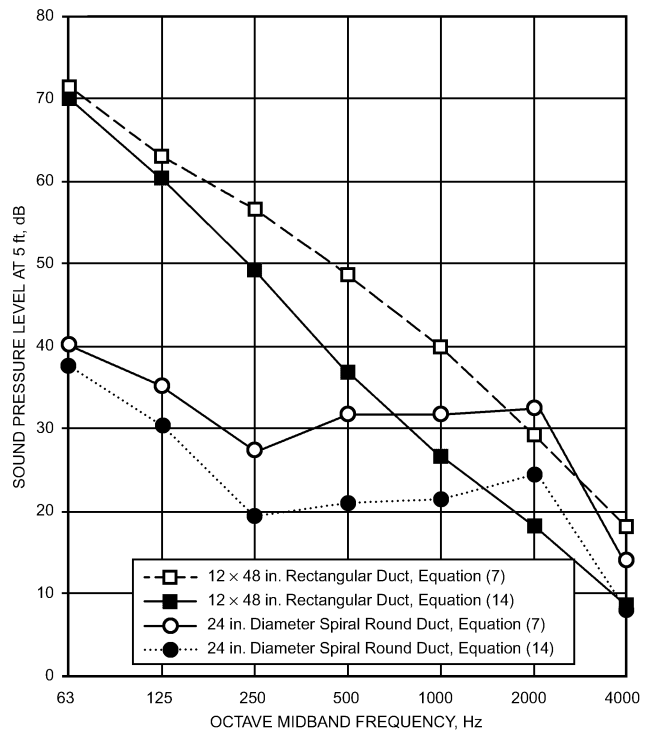

Fig. 27 Plotted Examples of Breakout Noise from Lined Duct

Values for TL_{in} for rectangular ducts are given in Table 25, for round ducts in Table 26, and for flat oval ducts in Table 27 (Cummins 1983, 1985).

RECEIVER ROOM SOUND CORRECTION

The sound pressure level at a given location in a room due to a particular sound source is a function of the sound power level and sound radiation characteristics of the sound source, the acoustic properties of the room (surface treatments, furnishings, etc.), the room volume, and the distance between the sound source and the point of observation. Two types of sound sources are typically encountered in HVAC system applications: **point source** and **line source**. Typical point sources are grilles, registers and diffusers; air-valve and fan-powered air terminal units and fan-coil units located in ceiling plenums; and return air openings. Line sources

are usually associated with sound breakout from air ducts and long slot diffusers.

For a point source in an enclosed space, classical diffuse-field theory predicts that as the distance between the source and point of observation is increased, the sound pressure level initially decreases at the rate of 6 dB per doubling of distance. At some point, the reverberant sound field begins to dominate and the sound pressure level remains at a constant level.

Investigators have found that diffuse-field theory does not apply in real-world rooms with furniture or other sound-scattering objects (Schultz 1985; Thompson 1981). Instead, the sound pressure levels decrease at the rate of around 3 dB per every doubling of distance between the sound source and the point of observation. Generally, a true reverberant sound field does not exist in small rooms (room volumes less than 15,000 ft³). In large rooms (room volumes greater than 15,000 ft³), reverberant fields usually exist, but typically at distances from the sound sources that are significantly greater than those predicted by diffuse-field theory.

Point Sound Sources

Most normally furnished rooms of regular proportions have acoustic characteristics that range from *average* to *medium dead*. These usually include carpeted rooms with sound-absorptive ceilings. If such a room has a volume less than 15,000 ft³ and the sound source is a single point source, sound pressure levels associated with the sound source can be obtained from

$$L_p = L_w + A - B \tag{19}$$

where

L_p = sound pressure level at specified distance from sound source, dB
 L_w = sound power level of sound source, dB

Table 25 TL_{in} Versus Frequency for Rectangular Ducts

Duct Size, in. × in.	Gage	TL_{out} , dB							
		Octave Midband Frequency, Hz							
		63	125	250	500	1000	2000	4000	8000
12 × 12	24	16	16	16	25	30	33	38	42
12 × 24	24	15	15	17	25	28	32	38	42
12 × 48	22	14	14	22	25	28	34	40	42
24 × 24	22	13	13	21	26	29	34	40	42
24 × 48	20	12	15	23	26	28	36	42	42
48 × 48	18	10	19	24	27	32	38	42	42
48 × 96	18	11	19	22	26	32	38	42	42

Note: Data are for duct lengths of 20 ft, but values may be used for cross-section shown regardless of length.

Table 26 Experimentally Measured TL_{in} Versus Frequency for Circular Ducts

Diameter, Length, in. ft	Gage	TL_{in} , dB							
		Octave Midband Frequency, Hz							
		63	125	250	500	1000	2000	4000	
Long Seam Ducts									
8 15	26	>17	(31)	39	42	41	32	31	
14 15	24	>27	43	43	31	31	28	22	
22 15	22	>28	40	30	30	30	24	22	
32 15	22	(35)	36	23	23	21	19	35	
Spiral Wound Ducts									
8 10	26	>20	>42	>59	>62	53	43	26	
14 10	26	>20	>36	44	28	31	32	22	
26 10	24	>27	38	20	23	22	19	33	
26 10	16	>30	>41	30	29	29	25	38	
32 10	22	>27	32	25	22	23	21	37	

Note: In cases where background sound swamped the sound radiated from duct walls, a lower limit on TL_{in} is indicated by >. Parentheses indicate measurements in which background sound produced greater uncertainty than usual.

Table 27 TL_{in} Versus Frequency for Flat Oval Ducts

Duct Size, in. × in.	Gage	TL_{in} , dB							
		Octave Midband Frequency, Hz							
		63	125	250	500	1000	2000	4000	
12 × 6	24	18	18	22	31	40	—	—	
24 × 6	24	17	17	18	30	33	—	—	
24 × 12	24	15	16	25	34	—	—	—	
48 × 12	22	14	14	26	29	—	—	—	
48 × 24	22	12	21	30	—	—	—	—	
96 × 24	20	11	22	25	—	—	—	—	
96 × 48	18	19	28	—	—	—	—	—	

Note: Data are for duct lengths of 20 ft, but values may be used for cross-section shown regardless of length.

Values for A and B are given in Tables 28 and 29. If a normally furnished room has a volume greater than 15,000 ft³ and the sound source is a single point source, sound pressure levels associated with the sound source can be obtained from

$$L_p = L_w - C - 5 \tag{20}$$

Values for C are given in Table 30. Equation (20) can be used for room volumes of up to 150,000 ft³, with accuracy typically within 2 to 5 dB.

Distributed Array of Ceiling Sound Sources

In many office buildings, air supply outlets are located flush with the ceiling of the conditioned space and constitute an array of distributed ceiling sound sources. The geometric pattern depends on the floor area served by each outlet, the ceiling height, and the thermal load distribution. In the interior zones of a building where thermal load requirements are essentially uniform, air delivery per outlet is usually the same throughout the space; thus, these outlets emit nominally equal sound power levels. One way to calculate sound pressure levels in a room with a distributed array is to use Equation (19) or (20) to calculate the sound pressure levels for each individual air outlet at specified locations in the room and then log-

Table 28 Values for A in Equation (19)

Room Volume, ft ³	Value for A , dB						
	Octave Midband Frequency, Hz						
	63	125	250	500	1000	2000	4000
1,500	4	3	2	1	0	-1	-2
2,500	3	2	1	0	-1	-2	-3
4,000	2	1	0	-1	-2	-3	-4
6,000	1	0	-1	-2	-3	-4	-5
10,000	0	-1	-2	-3	-4	-5	-6
15,000	-1	-2	-3	-4	-5	-6	-7

Table 29 Values for B in Equation (19)

Distance from Sound Source, ft	Value for B , dB
3	5
4	6
5	7
6	8
8	9
10	10
13	11
16	12
20	13

Table 30 Values for C in Equation (20)

Distance from Sound Source, ft	Value for C , dB						
	Octave Midband Frequency, Hz						
	63	125	250	500	1000	2000	4000
3	5	5	6	6	6	7	10
4	6	7	7	7	8	9	12
5	7	8	8	8	9	11	14
6	8	9	9	9	10	12	16
8	9	10	10	11	12	14	18
10	10	11	12	12	13	16	20
13	11	12	13	13	15	18	22
16	12	13	14	15	16	19	24
20	13	15	15	16	17	20	26
25	14	16	16	17	19	22	28
32	15	17	17	18	20	23	30

Table 31 Values for D in Equation (21)

Floor Area per Diffuser, ft ²	Value for D , dB						
	Octave Midband Frequency, Hz						
	63	125	250	500	1000	2000	4000
Ceiling height 8 to 9 ft							
100 to 150	2	3	4	5	6	7	8
200 to 250	3	4	5	6	7	8	9
Ceiling height 10 to 12 ft							
150 to 200	4	5	6	7	8	9	10
250 to 300	5	6	7	8	9	10	11
Ceiling height 14 to 16 ft							
250 to 300	7	8	9	10	11	12	13
350 to 400	8	9	10	11	12	13	14

arithmically add the sound pressure levels for each diffuser at each observation point. This calculation procedure can be very tedious for a room with a large number of ceiling air outlets.

For a distributed array of ceiling sound sources (air outlets) of nominally equal sound power, the room sound pressure levels tend to be uniform in a plane parallel to the ceiling. Although sound pressure levels decrease with distance from the ceiling along a vertical axis, the sound pressure levels along any selected horizontal plane are nominally constant. Equation (21) simplifies calculation for a distributed ceiling array. For this case, use a reference plane 5 ft above the floor.

Thus, $L_{p(5)}$ is obtained from

$$L_{p(5)} = L_{W(s)} - D \quad (21)$$

where

$L_{p(5)}$ = sound pressure level at distance of 5 ft above floor, dB

$L_{W(s)}$ = sound power level of single diffuser in array

Values of D for other ceiling heights are given in [Table 31](#).

Nonstandard Rooms

The previous equations assume the acoustical characteristics of most rooms. However, some rooms may be acoustically *medium live to live* (they have little sound absorption). These rooms may be sports or athletic areas, concert halls, or other rooms designed to be live, or they may be rooms that are improperly designed from an acoustic standpoint. The previous equations should not be used for acoustically live rooms because they can overestimate the decrease in sound pressure levels associated with the room sound correction by as much as 10 to 15 dB. When these or other types of nonstandard rooms are encountered, the classic diffuse equation for converting sound power to pressure should be used:

$$L_p = L_W + 10 \log \left(\frac{Q}{4\pi r^2} + \frac{4}{R} \right) + 10.5 \quad (22)$$

where

L_p = sound pressure level, dB (re 20 μ Pa)

L_W = sound power level, dB (re 10⁻¹² W)

Q = directivity of sound source, dimensionless—see [Figure 31](#)

r = distance from source, ft

R = sum of all surface areas and their corresponding absorption coefficients [$S\alpha/(1 - \alpha)$], ft²

A further discussion of assumptions used in converting power to pressure is available in [Chapter 7 of the ASHRAE Handbook—Fundamentals](#).

INDOOR SOUND CRITERIA

HVAC-related sound is often the major source of background noise in indoor spaces. Whether an occupant considers the background noise acceptable or not generally depends on two factors.

First is the **perceived loudness** of the noise relative to that of normal activities; if it is clearly noticeable, it is likely to be distracting and cause complaint. Second is the **quality** of the background noise; if the noise is perceived as a rumble, roar, hiss, or tone, this may result in complaints of annoyance and stress. The frequency spectrum is then said to be unbalanced.

The acoustical design must ensure that HVAC noise is of sufficiently low level and unobtrusive quality so as not to interfere with occupancy use requirements. If the background noise reduces speech intelligibility, for example, complaints of lost productivity can result. Accordingly, methods of rating HVAC-related noise should assess both perceived loudness and quality.

In the initial design and final commissioning phases of an HVAC system, sound criteria are needed to determine the degree of noise impact and the amount of noise and vibration reduction required for acceptable background sound and vibration levels based on occupancy usage. This section is intended primarily to assist with the design phase and provide limited assistance with diagnosis of problems. Detailed diagnosis of problems may require the assistance of an acoustical consultant or an engineer experienced in HVAC system noise and vibration analysis. The section on Testing for Sound and Vibration in [Chapter 36](#) of this volume should be consulted for the commissioning phase.

Sound Rating Methods

This section presents information to help the design engineer select the most appropriate background noise rating method for a specific project. Current methods include the traditional A-weighted sound pressure level (dBA) and tangent noise criteria (NC), the more recent room criterion (RC) and balanced noise criterion (NCB), and the newer RC Mark II. Each method was developed based on data for specific applications; hence, not all are equally suitable for the rating of HVAC-related noise in the variety of applications encountered. The preferred sound rating methods generally comprise two distinct parts: a family of criterion curves (specifying sound levels by octave bands), and a companion procedure for rating the calculated or measured sound data relative to the criterion curves.

Ideally, HVAC-related background noise should have the following characteristics:

- Balanced contributions from all parts of the sound spectrum with no predominant bands of noise
- No audible tones such as a hum or whine
- No fluctuations in level such as a throbbing or pulsing

Unfortunately, at this time there is no acceptable process to easily characterize the effects of audible tones and level fluctuations, so none of these rating methods address these issues. [Table 32](#) summarizes the essential differences, advantages, and disadvantages of rating methods that might be used to characterize HVAC-related background noise.

NC: Noise Criteria Method. The NC method for rating noise, described in [Chapter 7 of the ASHRAE Handbook—Fundamentals](#), has been used in North America and abroad for more than 30 years. It is a single-number rating that is somewhat sensitive to the relative loudness and speech interference properties of a given noise spectrum. The method consists of a family of criterion curves extending from 63 to 8000 Hz, and a **tangency rating procedure**. The criterion curves define the limits of octave band spectra that must not be exceeded to meet occupant acceptance in certain spaces. The rating is expressed as NC followed by a number (e.g., NC 40). The octave midband frequency of the point at which the spectrum is tangent to the NC curve should be reported.

Widely used and understood, the NC method is sensitive to level and has the disadvantage that the tangency method used to determine the rating does not require that the noise spectrum approximate the shape of the NC curves. Thus, different-sounding noises can have

Table 32 Comparison of Sound Rating Methods*

Method	Overview	Considers Speech Interference Effects	Evaluates Sound Quality	Components Presently Rated by Each Method
NC	Can rate components No quality assessment Does not evaluate low-frequency rumble	Yes	No	Air terminals Diffusers
RC	Used to evaluate systems Should not be used to evaluate components Can be used to evaluate sound quality Provides some diagnostic capability	Yes	Yes	
dBA	No quality assessment Frequently used for outdoor noise ordinances	Yes	No	Cooling towers Water chillers Condensing units
NCB	Can rate components Some quality assessment	Yes	Yes	
RC Mark II	Evaluates sound quality Provides improved diagnostics capability	Yes	Yes	

*None of the described methods effectively address the potential effect of sound level fluctuations and the presence of discrete tones.

the same numeric rating, but rank differently on the basis of sound quality. With the advent of VAV systems, excessive low-frequency noise below the 63 Hz octave band has become a serious problem, and the NC rating method does not address this (Ebbing and Blazier 1992). If the NC method is chosen, sound levels at frequencies below 63 Hz must be evaluated by other means. Specifications and design criteria can further restrict allowable sound levels.

In many HVAC systems that do not produce excessive low-frequency noise and strong discernable pure tones, the NC rating correlates relatively well with occupant satisfaction if sound quality is not a significant concern. NC rating is often used because of its simplicity.

RC: Room Criteria Method. ASHRAE previously recommended the room criterion (RC) curves (ANSI S12.2; ASHRAE 1995; Blazier 1981a, 1981b) as the preferred method for rating HVAC system related noise. The RC curves were intended to establish HVAC system design goals. *The revised RC Mark II method is now preferred.*

The RC method is a family of criterion curves and a rating procedure. The shape of these curves (similar to those for RC Mark II in Figure 29) represents a well-balanced, bland-sounding spectrum, including two additional octave bands (16 and 31.5 Hz) added to deal with excessive low-frequency noise. This rating procedure assesses background noise in spaces, both on the basis of its effect on speech, and on subjective sound quality. The rating value is expressed as RC followed by a number to show the level of the noise and a letter to indicate the quality [e.g., RC 35(N), where N denotes a desired neutral]. The RC method includes evaluation of the potential for noise-induced vibration from excessive airborne sound levels at and below 63 Hz.

dBA: A-Weighted Sound Level. The A-weighted sound level (described in Chapter 7 of the *ASHRAE Handbook—Fundamentals*) has been used for more than 40 years as a single-number measure of the relative loudness of noise, especially for outdoor environmental noise standards. The rating is expressed as a number followed by dBA (e.g., 40 dBA).

A-weighted sound levels can be measured with simple sound level meters. The ratings correlate well with human judgments of relative loudness but take no account of spectral balance or sound quality. Thus, many different-sounding spectra can result in the same numeric value, but have quite different subjective qualities.

The C-weighted sound level, denoted as dBC, is more sensitive to low-frequency sound contributions to the overall sound level than is dBA. A significant difference in the quantity (dBC – dBA) indicates that significant low-frequency sound is present.

NCB: Balanced Noise Criteria Method. The NCB method (ANSI S12.2; Beranek 1989) is used to specify or evaluate room

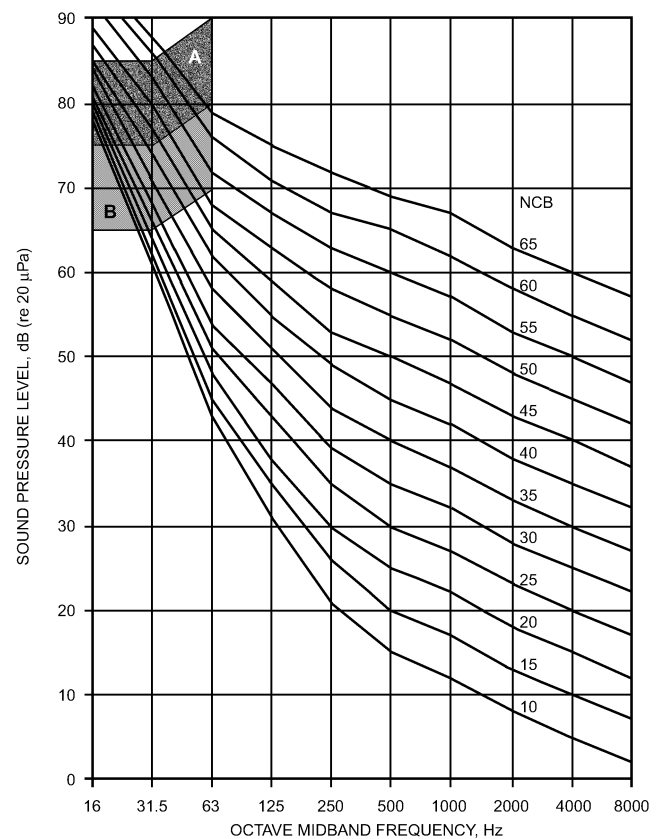

Fig. 28 NCB Noise Criterion Curves

noise, including that from occupant activities. The NCB criterion curves (Figure 28) are intended as an improvement over the NC curves by including the two low-frequency octave bands (16 and 31.5 Hz), and by lowering permissible noise levels at high frequencies (4000 and 8000 Hz). The NCB rating procedure is based on the speech interference level (SIL = the average of the four sound pressure levels at octave midband frequencies of 500, 1000, 2000, and 4000 Hz) with additional tests for rumble and hiss compliance. The rating is expressed as NCB followed by a number (e.g., NCB 40).

The NCB method is better than the NC method in determining whether a noise spectrum has an unbalanced shape sufficient to demand corrective action, and it addresses the issue of low-frequency

noise. The rating procedure is, however, more complicated than the familiar NC tangency method. The NCB method can still be used as a tangency method; if so used, the point of tangency, which sets the rating, must be denoted.

The NCB method evaluates low-frequency (16 and 31.5 Hz) sound levels with respect to the potential for noise-induced vibration. The NCB curves indicate that very high-amplitude sound levels maybe acceptable based on the limits of the criteria curves. The threshold of human hearing is high at low frequencies, and high-amplitude, low-frequency sound energy may be “felt” rather than heard. Building architectural and mechanical systems can be excited into vibration that produces unacceptable shaking, rattling, and re-radiation of noise. Anytime low-frequency sound levels exceed those indicated by the lower limit of zone A shown in [Figure 28](#), great care should be exercised in interpreting the acceptability of the results.

RC Mark II: Room Criteria Method. Based on experience and the findings from ASHRAE-sponsored research (Broner 1994), the RC method was revised to the RC Mark II method (Blazier 1997). Like its predecessor, the RC Mark II method is intended for rating the sound performance of an HVAC system as a whole. The method is most useful as a diagnostic tool for analyzing noise problems in the field. The RC Mark II method is more complicated to use than the RC method, but computerized spreadsheets and HVAC system analysis programs are available to perform the calculations and graphical analysis.

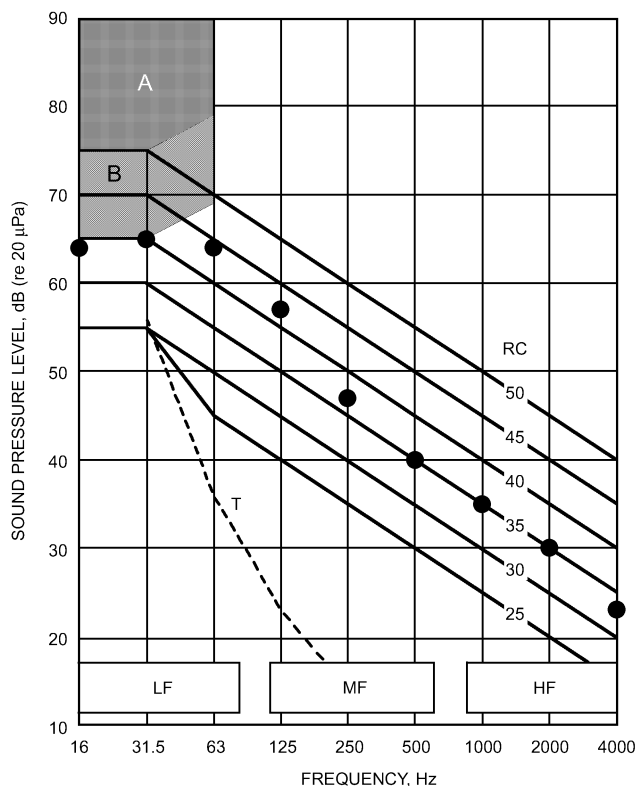

- Note:
- Noise levels for lightweight wall and ceiling constructions:
 - In shaded region B are likely to generate vibration that may be perceptible. There is a slight possibility of rattles in light fixtures, doors, windows, etc.
 - In shaded region A have a high probability of generating easily perceptible noise-induced vibration. Audible rattling in light fixtures, doors, windows, etc. may be anticipated.
 - Regions LF, MF, and HF are explained in the text.
 - Solid dots are sound pressure levels for the example discussed in the text.

Fig. 29 Room Criterion Curves, Mark II

The RC Mark II method has three parts: (1) a family of criterion curves ([Figure 29](#)), (2) a procedure for determining the RC numerical rating and the noise spectral balance (quality), and (3) a procedure for estimating occupant satisfaction when the spectrum does not have the shape of an RC curve (Quality Assessment Index) (Blazier 1995). The rating is expressed as RC followed by a number and a letter [e.g., RC 35(N)]. The number is the arithmetic average rounded to the nearest integer of the sound pressure levels in the 500, 1000, and 2000 Hz octave bands (the principal speech frequency region) and is known as the preferred speech interference level (PSIL). The letter is a qualitative descriptor that identifies the perceived character of the sound: (N) for neutral, (LF) for low-frequency rumble, (MF) for midfrequency roar, and (HF) for high-frequency hiss. There are also two subcategories of the low-frequency descriptor: (LF_B), denoting a moderate but perceptible degree of sound-induced ceiling/wall vibration, and (LF_A), denoting a noticeable degree of sound-induced vibration.

Each reference curve in [Figure 29](#) identifies the shape of a neutral, bland-sounding spectrum, indexed to a curve number corresponding to the sound level in the 1000 Hz octave band. The shape of these curves is based on Blazier (1981a, 1981b), modified at 16 Hz following recommendations of the research in Broner (1994). Regions A and B denote levels at which sound can induce vibration in light wall and ceiling construction, which can potentially cause rattles in light fixtures, furniture, etc. Curve T is the octave band threshold of hearing as defined by ANSI Standard 12.2.

Procedure for Determining the RC Mark II Rating for a System

Step 1. Obtain the arithmetic average of the sound levels in the principal speech frequency range represented by the levels in the 500, 1000, and 2000 Hz octave bands [Preferred Speech Interference Level (PSIL)]. [This is not to be confused with the ANSI-defined “speech-interference level” (SIL), a four-band average obtained by including the 4000 Hz octave band as used with the NCB method.] The RC reference curve is chosen to be that which has the same value at 1000 Hz as the calculated average value.

Step 2. Calculate the quality assessment index (QAI) (Blazier 1995), which measures the deviation of the spectrum under evaluation from the shape of the RC reference curve. Calculate the *energy-averaged* spectral deviations from the RC reference curve in each of three frequency groups: low frequency (LF; 16 to 63 Hz), medium frequency (MF; 125 to 500 Hz), and high frequency (HF; 1000 to 4000 Hz). (A simple arithmetic average of these deviations is often adequate for most engineering purposes.) Equation (23) gives the procedure for the LF region; repeat for the MF and HF regions by substituting the corresponding values at each frequency.

$$LF = 10 \log \left[\left(10^{0.1\Delta L_{16}} + 10^{0.1\Delta L_{31.5}} + 10^{0.1\Delta L_{63}} \right) / 3 \right] \quad (23)$$

In Equation (23), the ΔL terms are the differences between the spectrum being evaluated and the RC reference curve in each frequency band. In this way, three specific spectral deviation factors, expressed in dB with either positive or negative values, are associated with the spectrum being rated. QAI is the *range* in dB between the highest and lowest values of the spectral deviation factors.

If QAI ≤ 5 dB, the spectrum is assigned a *neutral* (N) rating. If QAI *exceeds* 5 dB, the sound quality descriptor of the RC rating is the letter designation of the frequency region of the deviation factor having the highest *positive* value.

Example 5. The spectrum plotted in [Figure 29](#) indicated by large dots is processed in [Table 33](#).

Table 33 Example 5 Calculation of RC Mark II Rating

	Frequency, Hz								
	16	31	63	125	250	500	1000	2000	4000
Spectrum levels	64	65	64	57	47	40	35	30	23
Average of 500 to 2000 Hz levels	35								
RC contour	60	60	55	50	45	40	35	30	25
Levels—RC contour	4	5	9	7	2	0	0	0	-2
		LF			MF			HF	
Spectral deviations	6.6		4.0			-0.6			
QAI	7.2								
RC Mark II rating	RC 35(LF)								

The arithmetic average of the sound levels in the 500, 1000, and 2000 Hz octave bands is 35 dB, so the RC 35 curve is selected as the reference for spectrum quality evaluation.

The spectral deviation factors in the LF, MF, and HF regions are 6.6, 4.0, and -0.6 respectively, giving a QAI of 7.2. The maximum positive deviation factor occurs in the LF region and QAI exceeds 5, therefore, the rating of the spectrum is RC 35(LF). An average room occupant should perceive this spectrum as rumbly in character.

Estimating Occupant Satisfaction using QAI. The QAI estimates the probable reaction of an occupant when the system design does not produce optimum sound quality. The basis for estimating occupant satisfaction is that changes in sound level of less than 5 dB do not cause subjects to change their ranking of sounds of similar spectral content. However, level changes greater than 5 dB do significantly affect subjective judgments. A QAI of 5 dB or less corresponds to a generally acceptable condition, provided that the perceived level of the sound is in a range consistent with the given type of space-occupancy as recommended in Table 34. (An exception to this rule occurs when the sound pressure levels in the 16 Hz or 31 Hz octave bands exceed 65 dB. In such cases, there is potential for acoustically induced vibration in typical lightweight office construction. If the levels in these bands exceed 75 dB, a significant problem with induced vibration is indicated.)

A QAI that exceeds 5 dB but is less than or equal to 10 dB represents a marginal situation, in which acceptance by an occupant is questionable. However, a QAI greater than 10 dB will likely be objectionable to the average occupant. Table 35 lists sound quality descriptors and QAI values and relates them to probable occupant reaction to the noise.

The numerical part of the RC rating may sometimes be less than the specified maximum for the space use, but with a sound quality descriptor other than the desirable (N). For example, a maximum of RC 40(N) is specified, but the actual noise environment turns out to be RC 35(MF). There is insufficient knowledge in this area to decide which spectrum is preferable.

Even at moderate levels, if the dominant portion of the background noise occurs in the very low-frequency region, some people can experience a sense of oppressiveness or depression in the environment (Perrson-Waye et al. 1997). Such a complaint may result after exposure to that environment for several hours, and thus may not be noticeable during a short exposure period.

Guideline Criteria for HVAC-Related Background Sound in Rooms

Table 34 lists design guidelines for HVAC-related background sound appropriate to various types of space-occupancies. Perceived loudness and task interference are factored into the numerical part of the RC rating. The sound-quality design target is assumed to be a neutral-sounding (N) spectrum, although some spectrum imbalance is probably tolerable within limits.

Table 34 Design Guidelines for HVAC-Related Background Sound in Rooms

Room Types	RC(N) (QAI ≤ 5 dB ^{a,b})
Residences, Apartments, Condominiums	25 to 35
Hotels/Motels	
Individual rooms or suites	25 to 35
Meeting/banquet rooms	25 to 35
Corridors, lobbies	35 to 45
Service/support areas	35 to 45
Office Buildings	
Executive and private offices	25 to 35
Conference rooms	25 to 35
Teleconference rooms	25 (max)
Open-plan offices	30 to 40
Corridors and lobbies	40 to 45
Hospitals and Clinics	
Private rooms	25 to 35
Wards	30 to 40
Operating rooms	25 to 35
Corridors and public areas	30 to 40
Performing Arts Spaces	
Drama theaters	25
Concert and recital halls ^c	
Music teaching studios	25
Music practice rooms	30 to 35
Laboratories (with fume hoods)	
Testing/research, minimal	
Speech communication	45 to 55
Research, extensive telephone use, speech communication	40 to 50
Group teaching	35 to 45
Church, Mosque, Synagogue	
General assembly with critical music programs ^c	25 to 35
Schools^d	
Classrooms	25 to 30
Large lecture rooms (without speech amplification)	25
Libraries	30 to 40
Courtrooms	
Unamplified speech	25 to 35
Amplified speech	30 to 40
Indoor Stadiums, Gymnasiums	
Gymnasiums and natatoriums ^e	40 to 50
Large seating-capacity spaces with speech amplification ^e	45 to 55

^aValues and ranges are based on judgment and experience, not on quantitative evaluations of human reactions. They represent general limits of acceptability for typical building occupancies. Higher or lower values may be appropriate and should be based on a careful analysis of economics, space usage, and user needs.

^bWhen quality of sound in the space is important, specify criteria in terms of RC(N). If quality of sound in the space is of secondary concern, the criteria may be specified in terms of NC or NCB levels of similar magnitude.

^cAn experienced acoustical consultant should be retained for guidance on acoustically critical spaces (below RC 30) and for all performing arts spaces.

^dSome educators and others believe that HVAC-related sound criteria for schools, as listed in previous editions of this table, are too high and impede learning for affected groups of all ages. See ANSI Standard S12.60-2002 for classroom acoustics and a justification for lower sound criteria in schools. The HVAC component of total noise meets the background noise requirement of that standard if HVAC-related background sound ≤ RC 25(N).

^eRC or NC criteria for these spaces need only be selected for the desired speech and hearing conditions.

Table 35 Definition of Sound-Quality Descriptor and Quality-Assessment Index (QAI), to Aid in Interpreting RC Mark II Ratings of HVAC-Related Sound

Sound-Quality Descriptor	Description of Subjective Perception	Magnitude of QAI	Probable Occupant Evaluation, Assuming Level of Specified Criterion is Not Exceeded
(N) Neutral (Bland)	Balanced sound spectrum, no single frequency range dominant	$QAI \leq 5$ dB, $L_{16}, L_{31} \leq 65$	Acceptable
		$QAI \leq 5$ dB, $L_{16}, L_{31} > 65$	Marginal
(LF) Rumble	Low-frequency range dominant (16 to 63 Hz)	5 dB $< QAI \leq 10$ dB	Marginal
		$QAI > 10$ dB	Objectionable
(LFV _B) Rumble, with moderately perceptible room surface vibration	Low-frequency range dominant (16 to 63 Hz)	$QAI \leq 5$ dB, $65 < L_{16}, L_{31} < 75$	Marginal
		5 dB $< QAI \leq 10$ dB	Marginal
		$QAI > 10$ dB	Objectionable
(LFV _A) Rumble, with clearly perceptible room surface vibration	Low-frequency range dominant (16 to 63 Hz)	$QAI \leq 5$ dB, $L_{16}, L_{31} > 75$	Marginal
		5 dB $< QAI \leq 10$ dB	Marginal
		$QAI > 10$ dB	Objectionable
(MF) Roar	Mid-frequency range dominant (125 to 500 Hz)	5 dB $< QAI \leq 10$ dB	Marginal
		$QAI > 10$ dB	Objectionable
(HF) Hiss	High-frequency range dominant (1000 to 4000 Hz)	5 dB $< QAI \leq 10$ dB	Marginal
		$QAI > 10$ dB	Objectionable

When these levels are used as a basis for compliance verification, the following additional information must be provided:

- What sound levels are to be measured (specify L_{eq} or L_{max} levels, etc., in each octave frequency band)
- Where and how the sound levels are to be measured (specify the space average over a defined area or specific points for a specified minimum time duration, etc.)
- What type(s) of instruments are to be used to make the sound measurements (specify ANSI or IEC Type 1 or Type 2 sound level meters with octave band filters, etc.)
- How the instruments used for the sound measurements are to be calibrated or checked (specify that instruments are to be checked with an acoustical calibrator both before and after taking sound level measurements, etc.)
- How sound level measurements are to be adjusted for the presence of other sound sources (specify that background sound level measurements be performed without the other sound sources under consideration operating; if background sound levels are within 10 dB of operational sound levels, then corrections shall be performed; etc.)
- How the results of the sound measurements are to be interpreted (specify whether octave band sound levels, NC, RC, dBA, or other values are to be reported)

Unless these six points are clearly stipulated, the specified sound criteria may be unenforceable.

When applying the levels specified in [Table 34](#) as a basis for design, sound from non-HVAC sources, such as traffic and office equipment, may establish the lower limit for sound levels in a space.

NOISE FROM PLUMBING SYSTEMS

Acceptable noise levels from plumbing fixtures and piping have not been previously identified in the literature. Continuous noise from plumbing fixtures and piping systems with circulating fluids should meet the same noise criteria as HVAC systems. However, many sounds from plumbing fixtures and piping are of short duration or are transient, and typically have a somewhat higher threshold of acceptance. Examples of these sources include water flow noise associated with typical restroom fixtures; noise from waste lines connected to restroom, kitchen, and/or laundry drains; and noise from jetted bathtubs. The following table presents suggested maximum A-weighted sound pressure levels for various transient plumbing noise sources in buildings with multiple occupancies. These criteria are minimum standards and are intended to apply to plumbing systems serving adjacent and nearby units in multifamily

housing projects (apartments and condominiums), hospitals, educational facilities, and office buildings. Plumbing noise levels in high-end luxury condominiums should be 5 to 10 dB lower than the levels listed below.

Receiving (listening) room	L_{max} (slow response)
Residential bedroom/living room/dining room	35
Hospital patient room/classroom	40
Private office/conference room	40
Residential bathroom/kitchen	45
Open office/lobby/corridor	50

Achieving the recommended plumbing noise criteria in the finished space will usually require special attention to pipe installation details, selection of suitable piping materials, and selection of appropriate fixtures.

OUTDOOR SOUND CRITERIA

Acceptable outdoor sound levels are generally specified by local noise ordinances. Local noise ordinances almost always use the A-weighted noise level (dBA) as their metric. The usual metric is either L_{max} (maximum noise level over a period), L_{eq} (average noise level over a period), or L_p (no indication of the measure). The time constant used for L_{max} or L_p depends on the community code. Some communities have no ordinance and depend on state regulations. These often use the day-night noise level descriptor L_{DN} , a combination of the daytime (7:00 A.M. to 10:00 P.M.) and nighttime (10:00 P.M. to 7:00 A.M.) average noise levels (L_{eq}) with a 10 dB penalty for nighttime (Cowan 1994; Schultz 1972).

Measurement or estimation of community noise is based on a location, often at the receiver's property line, from a height of approximately 4 ft to any height, but can be anywhere within the property line, and often at the building of the closest dwelling unit. Alternatively, the measurement may be made at the property line of the noise source.

In the absence of a local noise ordinance, county or state laws or codes, or those of a similar community should be used. Even if activity noise levels do not exceed those specified by an ordinance, community acceptance is not ensured. Very low ambient levels or a noise source with an often-repeated time-varying characteristic may increase the likelihood of complaints.

Although most ordinances are given as A-weighted pressure level, attenuation by distance, barriers, buildings, and atmosphere are all frequency dependent. Thus, A-weighted levels do not give an accurate estimation of noise levels at distances from the source. If the A-weighted sound levels of sources must be determined by

means other than measurement, then octave band or one-third octave band measurements of the source sound pressure level at a distance, or (preferably) sound power level, must be obtained before calculating the attenuation.

**MECHANICAL EQUIPMENT ROOM
SOUND ISOLATION**

Locating HVAC equipment in a common room allows the designer to control noise affecting nearby spaces. Often, these spaces have background noise level criteria that dictate the type of construction and treatment necessary to achieve sufficient reduction in equipment noise transmitted to other spaces.

The most effective noise control measure for indoor mechanical equipment rooms is to locate them as far away as possible from noise-sensitive areas. In some cases, this will require a separate structure, such as a central chiller plant, to house the equipment. Subterranean basement locations are typically the best for noisy equipment because the basement usually affects the fewest adjacent locations. Penthouse equipment rooms are common but can create significant challenges for noise and vibration isolation. Rooms containing air-handling units should provide sufficient room for the equipment and associated ductwork to allow smooth transitions and full-radius curved elbows. A building corner location can work well by reducing the number of adjacent interior spaces and the amount of associated outside-air ductwork. Using adjacent spaces such as corridors, closets, and storage rooms as buffer zones can provide effective noise control. A common mistake in locating mechanical equipment rooms is to position the room in the core of the building between a stair, an elevator shaft, and a telecommunications closet, leaving only one wall where supply and return air ductwork can enter and leave the room. This leads to high-velocity air in the ductwork and high static pressures for fans to overcome, leading to higher noise levels.

Once the mechanical equipment room location has been established, the amount of noise created in the room should be assessed and appropriate constructions selected for walls, ceilings, and floors. Concrete masonry units of various available thickness and densities are often used for their durability and effectiveness in reducing low-frequency noise levels. Typically, heavier and thicker materials will contain more sound within the space. Special masonry units that provide a limited amount of acoustical absorption using slotted openings and resonator cavities can also be used.

Significant improvement in the sound isolation of a masonry wall can be achieved using furred-out gypsum wallboard and insulation in the cavities. Chillers and other equipment with very high noise levels are best situated in rooms with concrete masonry unit walls.

Often, because of structural issues and weight limitations, mechanical equipment room walls are built from gypsum wallboard on metal or wood studs. To adequately attenuate low-frequency noise, sufficient mass and thickness must be provided in the wall partition construction. This typically entails using multiple levels of gypsum wallboard on both sides of the wall with batt insulation in the cavities. Where greater levels of noise reduction are required, walls are built on double, staggered stud construction using two separate rows of studs on separate tracks with multiple layers of gypsum wallboard and batt insulation in the cavities.

For all types of walls, service penetrations should be fully caulked and sealed. Pipes, ducts, and conduits that penetrate the walls, ceilings or floors of mechanical rooms should be acoustically treated. Typically, a 0.5 in. gap around the penetrating element is filled with an appropriate material such as mineral fiber insulation. The penetration is then sealed airtight with resilient caulk (Figure 30).

Doors into mechanical equipment rooms are frequently the weak link in the enclosure. Where noise control is important, the doors should be as heavy as possible, gasketed around the perimeter, have no grilles or other openings, and be self-closing. If such doors lead to sensitive spaces, two doors separated by a 3 to 10 ft corridor may be necessary.

Penetration of Walls by Ducts

Ducts passing through the mechanical equipment room enclosure pose an additional problem. Sound can be transmitted to either side of the wall via the duct walls. Airborne sound in the mechanical room can be transmitted into the duct (break-in) and enter an adjacent space by re-radiating (breakout) from the duct walls, even if the duct contains no grilles, registers, diffusers, or other openings.

Sound levels in ducts close to fans are usually high. Sound can come not only from the fan but also from pulsating duct walls, excessive air turbulence, and air buffeting caused by tight or restricted fan airflow entrance or exit configurations. Duct layout for good aerodynamics and airflow conditions should minimize low-frequency sound generation, which, once generated, is difficult

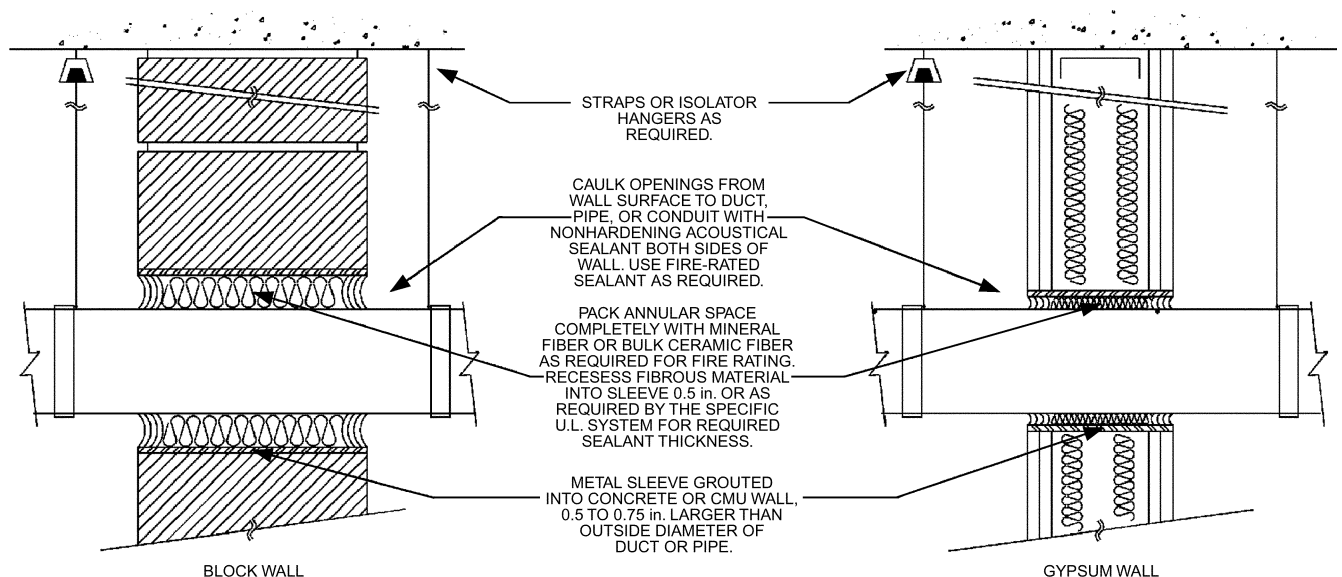

Fig. 30 Duct, Conduit, and Pipe Penetration Details

Table 36 Sound Transmission Class (STC) and Transmission Loss Values of Typical Mechanical Equipment Room Wall, Floor, and Ceiling Types, dB

Room Construction Type	STC	Octave Midband Frequency, Hz						
		63	125	250	500	1000	2000	4000
8 in. concrete masonry unit (CMU)	50	35	35	41	44	50	57	64
8 in. CMU with 5/8 in. gypsum wallboard (GWB) on furring strips	53	33	32	44	50	56	59	65
5/8 in. GWB on both sides of 3 5/8 in. metal studs	38	18	16	33	47	55	43	47
5/8 in. GWB on both sides of 3 5/8 in. metal studs with fiberglass insulation in cavity	49	16	23	44	58	64	52	53
2 layers of 5/8 in. GWB on both sides of 3 5/8 in. metal studs with fiberglass insulation in cavity	56	19	32	50	62	67	58	63
Double row of 3 5/8 in. metal studs, 1 in. apart, each with 2 layers of 5/8 in. GWB and fiberglass insulation in cavity	64	23	40	54	62	71	69	74
6 in. solid concrete floor/ceiling	53	40	40	40	49	58	67	76
6 in. solid concrete floor with 4 in. isolated concrete slab and fiberglass insulation in cavity	72	44	52	58	73	87	97	100
6 in. solid concrete floor with two layers of 5/8 in. GWB hung on spring isolators with fiberglass insulation in cavity	84	53	63	70	84	93	104	105

Note: Actual material composition (e.g., density, porosity, stiffness) affects transmission loss and STC values.

or impossible to remove, especially near noise-sensitive areas. Avoid elements conducive to increased breakout noise transmission and/or with a tendency to vibrate at low frequencies because of non-laminar airflow. Round ductwork is most resistant to these problems, followed by square ducts and rectangular ducts with aspect ratios less than 2:1. Heavier-than-normal gage metal ductwork, such as 16 ga within the mechanical room and over noise-sensitive spaces, can also be used.

Mechanical Chases

Mechanical chases and shafts should be acoustically treated the same way as mechanical equipment rooms, especially if they contain noise-producing ductwork, pipes, and equipment such as fans and pumps. The shaft should be closed at the mechanical equipment room, and shaft wall construction must provide sufficient reduction of mechanical noise from the shaft to noise-sensitive areas to obtain acceptable noise levels. Chases should not be allowed to become “speaking tubes” between spaces requiring different acoustical environments. Crosstalk through the shaft must be prevented. Pipes, ducts, conduits, or equipment should be vibration-isolated so that mechanical vibration and structure-borne noise is not transmitted to the shaft walls and into the building structure.

When mechanical equipment rooms are used as supply or return plenums, all openings into the equipment room plenum space may require noise control treatment, especially if any sound critical space is immediately adjacent. This is particularly true if the space above an acoustical tile ceiling just outside the equipment room is used as a return air plenum. Most acoustical tile ceilings are almost acoustically transparent at low frequencies.

Often supply ducts are run inside a chase also used for return air. It is best to attenuate the supply and return paths at the fan rather than let duct breakout noise require additional noise control at the chase return air inlets. Care should be used to prevent turbulent noise generation in the supply duct through proper supply duct design.

Special Construction Types

Sound transmission loss values for some typical constructions are given in Table 36. These data are compiled from controlled laboratory tests and represent a condition typically superior to that found in field installations. The acoustical performance of any wall, floor or ceiling is adversely affected by flanking paths, holes, penetrations, and other anomalies. Flanking paths include intersections of the wall, floor, or ceiling surface with another wall, floor, or ceiling that is structurally connected. Higher levels of sound isolation

can be achieved by decoupling the surfaces and using double-walled, floating floor, or barrier-ceiling constructions.

Floating Floors and Barrier Ceilings

Correctly installed floating floors and barrier ceilings can provide very high levels of sound isolation, allowing mechanical equipment rooms to be placed adjacent to noise-sensitive spaces. Like double-walled construction, these configurations decouple two surfaces by providing separate supporting structures. However, these types of construction can add significant cost and coordination complexity and should be carefully evaluated.

In a floating floor, the upper floor slab is typically a 4 in. concrete slab resting on vibration isolators supported by the subfloor—typically another concrete slab of appropriate thickness. An air gap is maintained between the two slabs and resilient materials are used around the perimeter of the upper slab to decouple it from surrounding walls. Any heavy equipment should be supported from the subfloor slab, not the floating floor.

Similarly, barrier ceilings are typically composed of multiple layers of gypsum wallboard attached to a frame suspended from the structure above with vibration-isolating hangers. Ductwork, piping, and other equipment is not supported from the floating ceiling but from the structure above it. This requires careful coordination of hangers and supports before installing the acoustical barrier ceiling.

The design and selection of the floating floor or ceiling should be carefully considered to properly support the dead and live loads it must carry. The floating system (floor or ceiling) *is not meant as a means of equipment vibration isolation and serves primarily to control airborne sound transmission.* The acoustical performance of the floating system depends greatly on the quality of construction, which requires careful coordination between all trades. All penetrations and intersections with other surfaces must allow the floor or ceiling to float without any rigid connections. This typically entails maintaining clearances of at least 0.25 in. and filling all gaps with resilient materials such as nonhardening caulk.

SOUND TRANSMISSION IN RETURN AIR SYSTEMS

The fan return air system provides a sound path (through ducts or through a ceiling plenum) between a fan and occupied rooms. Where there is a direct opening to the mechanical equipment room from the ceiling plenum, high sound levels in adjacent spaces can occur. The high sound levels originate from the fan and other sources in the mechanical equipment room. Low system attenuation between the mechanical equipment room and adjacent spaces exacerbates the problem.

Fan intake sound power levels control the sound in ducted return air systems; sound power levels of the fan intake and casing-radiated noise components affect plenum return air systems. In certain installations, sound from other equipment located in the mechanical equipment room may also radiate through the wall opening and into adjacent spaces. Good design yields room return air system sound levels that are approximately 5 dB below the corresponding room supply air system sound levels.

When sound levels in spaces adjacent to mechanical equipment rooms are too high, noise control measures must be provided. The controlling sound paths between the mechanical equipment room and adjacent spaces must be identified. Ducted return air systems can be modified using methods applicable to ducted supply systems. Ceiling plenum return systems should only be used for spaces that are remote from mechanical equipment rooms.

Ceiling plenum systems may require additional modifications. Prefabricated silencers can be effective when installed at the mechanical equipment room wall opening or at the suction side of the fan. Improvements in ceiling transmission loss are often limited by typical ceiling penetrations and lighting fixtures. Modifications to the mechanical equipment room wall can be effective for some constructions. Adding acoustical absorption in the mechanical equipment room reduces the buildup of reverberant sound energy in this space; however, this typically reduces high-frequency noise by a maximum of 4 dB and low-frequency noise only slightly in areas near the return opening.

SOUND TRANSMISSION THROUGH CEILINGS

When terminal units, fan-coil units, air-handling units, ducts, or return air openings to mechanical equipment rooms are located in a ceiling plenum above a room, sound transmission through the ceiling system can be high enough to cause excessive noise levels in that room. There is no standard test procedure for measuring direct transmission of sound through ceilings from sources close to the ceiling. As a result, ceiling product manufacturers rarely publish data that can be used in calculations. The problem is complicated by the presence of light fixtures, diffusers, grilles, and speakers that reduce the transmission loss of the ceiling. Experiments have shown that for ceiling panels supported in a T-bar grid system, the leakage between the panels and the grid is the major transmission path; differences among panel types are small, and light fixtures, diffusers, etc., have only a localized effect.

Table 37 Environmental Correction to Be Subtracted from Device Sound Power

Octave Band Frequency, Hz						
63	125	250	500	1000	2000	4000
4	2	1	0	0	0	0

Table 38 Compensation Factors for Source Area Effect

Area range, ft ²			
63 Hz	125 Hz	250 Hz	Adjustment, dB
less than 2.6	less than 2.2		-3
2.8 to 4.9	2.4 to 4.6	less than 2.3	-2
5.1 to 7.2	4.9 to 7.1	2.7 to 6.3	-1
7.4 to 9.4	7.3 to 9.5	6.7 to 10.3	0
9.7 to 11.7	9.8 to 12.0	10.7 to 14.3	1
11.9 to 14.0	12.2 to 14.4	14.7 to 18.3	2
14.2 to 16.3	14.6 to 16.8	18.7 to 22.3	3
16.5 to 18.5	17.1 to 19.3		4
18.8 to 20.8	19.5 to 21.7		5
21.0 to 23.1			6

Note: Find correct area in each frequency column and read adjustment from last column on right.

To estimate room sound pressure levels associated with sound transmission through the ceiling, the sound power levels in the ceiling plenum must be adjusted to account for the transmission loss of the ceiling system and plenum. An adjustment to measured data must also be made to account for sound absorption in the room. The procedures given here are based on ASHRAE research (Warnock 1997):

1. Obtain the octave band radiated sound power levels of the device.
2. Subtract the environmental correction from [Table 37](#).
3. Calculate the surface area of the bottom panel of the source closest to the ceiling tiles (ft²).
4. From [Table 38](#) find the adjustment to be subtracted from the sound power values at the three frequencies given there.
5. Select the Ceiling/Plenum attenuation from [Table 24](#) according to the ceiling type in use.
6. Subtract the three sets of values, taking account of sign where necessary, from the sound power values. The result is the average sound pressure level in the room.
7. The sound field in the room may be assumed as uniform up to distances of 16 ft from the source.

Example 7. A terminal unit with an area of 14 ft² and a known sound power level is to be used above a standard 5/8 in. thick mineral fiber ceiling system in a T-bar grid. What room sound pressure levels can be expected?

Solution:

Step	Octave Band Frequency, Hz						
	63	125	250	500	1000	2000	4000
1 Sound power	71	71	65	55	54	53	45
2 Environmental (Table 37)	-4	-2	-1	0	0	0	0
4 Area adjustment (Table 38)	-2	-2	-1	0	0	0	0
5 Ceiling/plenum (Table 24)	-13	-15	-17	-19	-25	-30	-33
6 Room sound pressure levels, dB	52	52	46	36	29	23	12

FUME HOOD DUCT DESIGN

Fume hood exhaust systems are often the major sound source in a laboratory. The exhaust system may consist of individual exhaust fans ducted to separate fume hoods, or a central exhaust fan connected through a collection duct system to a large number of hoods. In either case, sound pressure levels produced in the laboratory space should be estimated using procedures described in this section and manufacturer-supplied noise emission data. Recommended noise level design criteria for laboratory spaces using fume hoods are given in [Table 34](#).

To minimize static pressure loss and blower power consumption within a duct system, fume hood ducts should be of sufficient size to permit rated airflow at no greater than 2000 fpm or at a velocity consistent with regulatory requirements. Duct velocities in excess of 2000 fpm should be avoided for acoustical reasons and to conserve energy.

Noise control measures for fume hood systems include the following:

- Where conditions permit, use backward-inclined or forward-curved fans instead of radial-blade fans.
- Select the fan to operate at a low tip speed and maximum efficiency.
- Use prefabricated duct silencers or sections of lined ducts where conditions permit.

All potential noise control measures should be carefully evaluated for compliance with applicable codes, safety requirements, and corrosion resistance requirements of the specific fume hood system. In addition, vibration isolation for fume hood exhaust fans is generally required. However, for some laboratory facilities, particularly

those with highly vibration-sensitive instruments such as electron microscopes, vibration control can be critical, and a vibration specialist should be consulted.

SOUND CONTROL FOR OUTDOOR EQUIPMENT

Outdoor mechanical equipment should be carefully selected, installed, and maintained to prevent sound radiated by the equipment from annoying people outdoors or in nearby buildings and from violating local noise codes. The difference between sound levels at the listening location with the equipment operating and the ambient conditions with the equipment not operating determines whether the noise from the equipment is annoying. Equipment with strong tonal components is more likely to provoke complaints than equipment with a broadband noise spectrum.

Sound Propagation Outdoors

If the equipment sound power level spectrum and ambient sound pressure level spectrum are known, the contribution of the equipment to the sound level at any location can be estimated by analyzing the sound transmission paths involved. When there are no intervening barriers and no attenuation because of berms, ground absorption, or atmospheric effects, the principal factor in sound pressure level reduction is distance. The following equation may be used to estimate the sound pressure level of equipment at a distance from it and at any frequency when the sound power level is known:

$$L_p = L_w + 10 \log Q - 20 \log d \tag{24}$$

where

- d = distance from acoustic center of source to distant point, ft
- L_p = sound pressure level at distance d from sound source, dB
- L_w = sound power level of sound source, dB
- Q = directivity factor associated with way sound radiates from sound source (see Figure 31)

Equation (24) does not apply where d is less than twice the maximum dimension of the sound source. L_p may be low by up to 5 dB where d is between two and five times the maximum sound source dimension. Also, if the distance is greater than about 500 ft, wind,

thermal gradients, and atmospheric sound absorption need to be considered.

For complex cases, refer to texts in acoustics (e.g., Beranek 1971) and international standards such as ISO Standard 9613-2 (see the Standards section of this chapter).

Sound Barriers

A sound barrier is a solid structure that intercepts the direct sound path from a sound source to a receiver. It reduces the sound pressure level within its shadow zone. Figure 32 illustrates the geometrical aspects of an outdoor barrier where no extraneous surfaces reflect sound into the protected area. Here the barrier is treated as an intentionally constructed noise control structure. If a sound barrier is placed between a sound source and receiver location, the sound pressure level L_p in Equation (24) is reduced by the insertion loss (IL) associated with the barrier.

Table 39 gives the insertion loss of an outdoor ideal solid barrier when

- No surfaces reflect sound into the shadow zone, and
- The sound transmission loss of the barrier wall or structure is at least 10 dB greater at all frequencies than the insertion loss expected of the barrier.

The path-length difference referred to in Table 39 is given by

$$\text{Path-length difference} = A + B - D \tag{25}$$

where A , B , and D are as specified in Figure 32.

The limiting value of about 24 dB is caused by scattering and refraction of sound into the shadow zone formed by the barrier. Practical constructions such as size and space restrictions often limit sound barrier performance to 10 to 15 dBA. For large distances outdoors, this scattering and bending of sound waves into the shadow zone reduces barrier effectiveness. At large distances, atmospheric conditions can significantly affect sound path losses by amounts even greater than those provided by the barrier, with typical differences of 10 dBA. For a conservative estimate, the height of the sound source location should be taken as the topmost part of the sound source, and the height of the receiver should be taken as the topmost location of a sound receiver, such as the top of the second-floor windows in a two-floor house or at a height of 5 ft for a standing person.

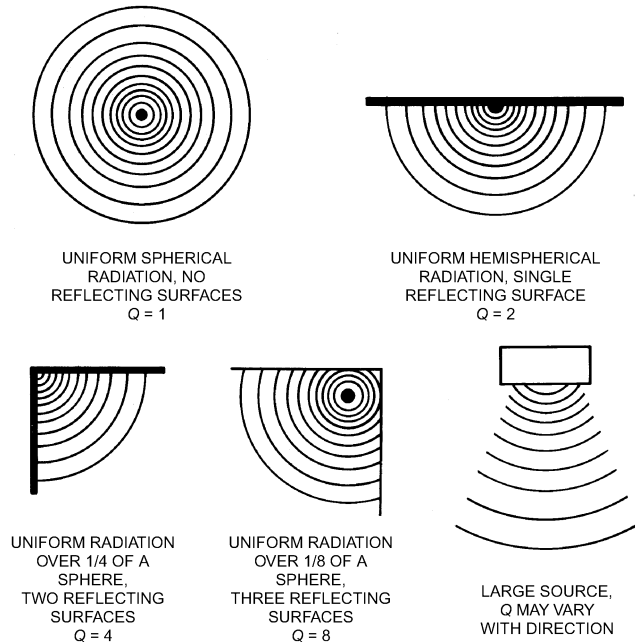

Fig. 31 Directivity Factors for Various Radiation Patterns

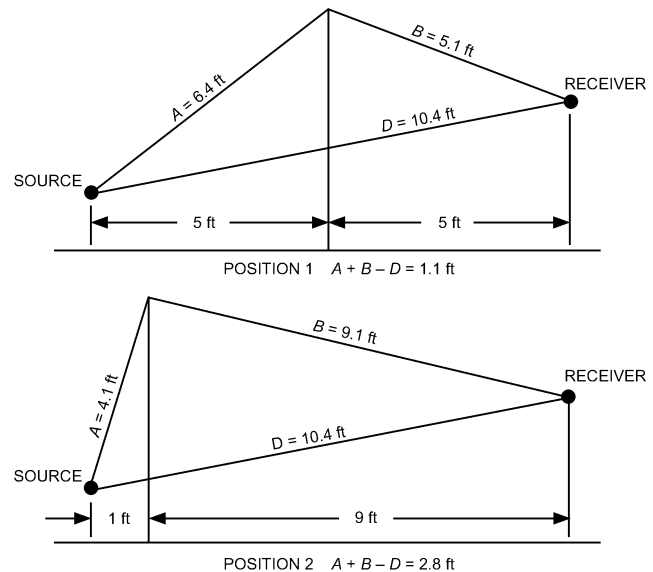

Fig. 32 Noise Barrier

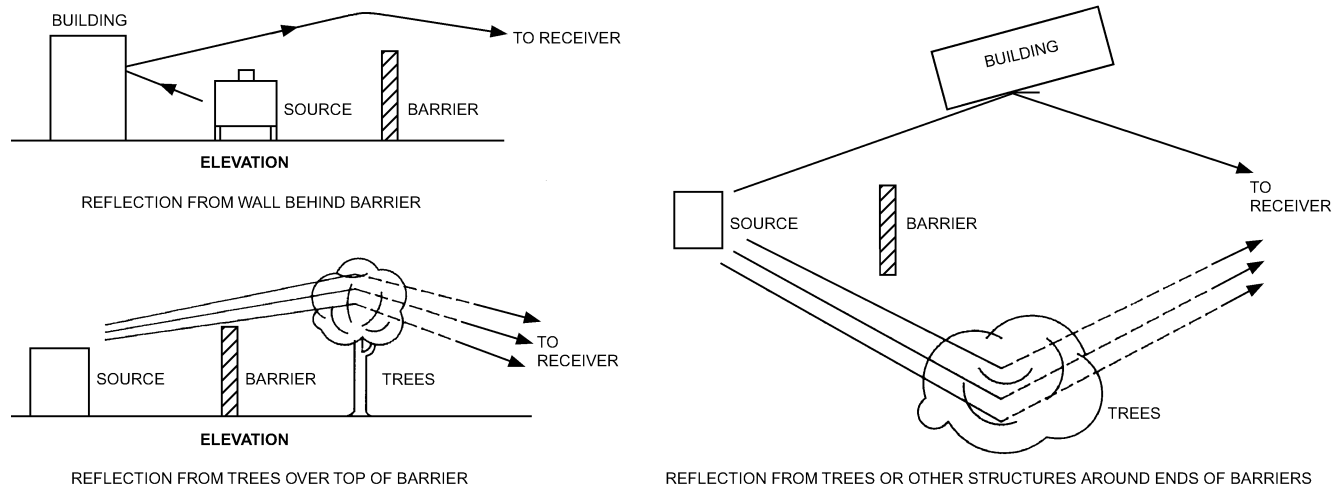

Fig. 33 Reflecting Surfaces That Can Diminish Barrier Effectiveness

Table 39 Insertion Loss Values of Ideal Solid Barrier

Path-Length Difference, ft	Insertion Loss, dB							
	Octave Midband Frequency, Hz							
	31	63	125	250	500	1000	2000	4000
0.01	5	5	5	5	5	6	7	8
0.02	5	5	5	5	5	6	8	9
0.05	5	5	5	5	6	7	9	10
0.1	5	5	5	6	7	9	11	13
0.2	5	5	6	8	9	11	13	16
0.5	6	7	9	10	12	15	18	20
1	7	8	10	12	14	17	20	22
2	8	10	12	14	17	20	22	23
5	10	12	14	17	20	22	23	24
10	12	15	17	20	22	23	24	24
20	15	18	20	22	23	24	24	24
50	18	20	23	24	24	24	24	24

Reflecting Surfaces. No other surfaces should be located where they can reflect sound around the ends or over the top of the barrier into the barrier shadow zone. Figure 33 shows examples of reflecting surfaces that can reduce the effectiveness of a barrier wall.

Width of Barrier. Each end of the barrier should extend horizontally beyond the line of sight from the outer edge of the source to the outer edge of the receiver position by a distance of at least three times the path-length difference. Near the ends of the barrier, the effectiveness of the noise isolation is reduced because some sound is diffracted over the top and around the ends. Also, some sound is reflected or scattered from various nonflat surfaces along the ground near the ends of the barrier. In critical situations, the barrier should completely enclose the sound source to eliminate or reduce the effects of reflecting surfaces.

Reflection from a Barrier. A large, flat reflecting surface, such as a barrier wall, may reflect more sound toward the source than there would have been with no wall present. If the wall produces no special focusing effect, reflections from the wall will produce levels on the side of the barrier facing the source that are 2 to 3 dB higher. Using acoustical absorption on the barrier surface (source side) mitigates this increase.

HVAC NOISE REDUCTION DESIGN PROCEDURES

These HVAC system design procedures address the 63 to 4000 Hz octave band frequency range. Although it is desirable to extend this

frequency range down into the 31.5 Hz octave band, acoustical calculations below the 125 Hz octave band are not reliable. With few exceptions, if acoustical design criteria are met at 4000 Hz, then the 8000 Hz requirements should also be met. The guidelines in this chapter and other guides maximize the probability of meeting acoustical design criteria in the 31.5 to 8000 Hz octave bands. Thus, there is a reasonable probability that the acoustical design criteria will be met when the following requirements are met:

- Systems are designed in accordance with the equipment selection, placement, and integration guidelines in this chapter, other ASHRAE guides, and manufacturers’ application notes and bulletins.
- Acoustical calculations based on the information included in this chapter and the information provided by the equipment manufacturer indicate that the system will not exceed the selected acoustical design criteria values in the 63 to 4000 Hz octave band frequency range.

The following design procedure is suggested. It uses the RC criterion; however, other criteria, such as NC and NCB, could be used.

1. Determine the design goal for HVAC system noise for each critical area according to its use and construction. Choose the desirable RC criterion from Table 3.3. A balanced sound spectrum is often as important as the overall sound level.
2. Select equipment and fittings, such as air inlet and outlet grilles, registers, diffusers, and air terminal and fan-coil units that radiate sound directly into a room, that will be quiet enough to meet design goals.
3. Complete an initial design and layout of the HVAC system, using acoustical treatment such as lined ductwork and duct silencers where appropriate. Consider supply, return, and exhaust air paths.
4. Add the sound attenuation and sound power levels associated with the central fan(s), fan-powered terminal units (if used), and duct elements between the central fan(s) and the room of interest, and convert to the corresponding sound-pressure levels in the room. For a more complete estimate of resultant sound levels, start at the AHU or fan, and consider regenerated and self noise from duct silencers and air inlets and outlets caused by the airflow itself. Investigate both the supply and return air paths in similar ways. Investigate and control possible duct sound breakout when fans are adjacent to the room of interest or roof-mounted fans are above the room of interest. Combine the sound contribution from all paths into the occupied space of concern. See Example 8 for a sample of

calculation procedures for supply and return air paths, including duct breakout noise contributions.

5. If the mechanical equipment room is adjacent to the room of interest, determine the sound-pressure levels in the room of interest that are associated with sound transmitted through the mechanical equipment room wall. Air-handling units, ventilation and exhaust fans, chillers, pumps, electrical transformers, and instrument air compressors are typical equipment to consider. Also consider the vibration isolation requirements for equipment, piping, and ductwork.
6. Combine on an energy basis (see Example 8 for sample calculation procedures) the sound-pressure levels in the room of interest that are associated with all sound paths between the mechanical equipment room or roof-mounted unit and the room of interest.
7. Determine the corresponding RC level associated with the calculated total sound-pressure levels in the room of interest. Take special note of the sound quality indicators for possible rumble, roar, hiss, tones, and perceivable vibration.
8. If the RC level exceeds the design goal, determine the octave frequency bands in which the corresponding sound pressure levels are exceeded and the sound paths associated with these octave frequency bands. If resultant noise levels are high enough to cause perceivable vibration, consider both airborne and structure-borne noise.
9. Redesign the system, adding additional sound attenuation to paths that contribute to excessive sound-pressure levels in the room of interest. If resultant noise levels are high enough to cause perceivable vibration, then major redesign and possibly use of supplemental vibration isolation for equipment and building systems are often required.
10. Repeat Steps 4 through 9 until the desired design goal is achieved. Involve the complete design team where major

problems are found. Often, simple design changes to building architectural and equipment systems can eliminate potential problems once the problems are identified.

11. Repeat Steps 3 through 10 for every room that is to be analyzed.
12. Make sure that noise radiated by outdoor equipment such as air-cooled chillers and cooling towers will not disturb adjacent properties or interfere with criteria established in Step 1 or any applicable building or zoning ordinances.

Example 8: Previous examples demonstrate how to calculate equipment- and airflow-generated sound-power levels and sound-attenuation values associated with the elements of HVAC air distribution systems. This example shows how the information can be combined to determine sound-pressure levels associated with a specific HVAC system. Only a summary of tabulated results is listed rather than showing complete calculations for each element.

Air is supplied to the HVAC system by the rooftop unit shown in Figure 34. The receiver room is directly below the unit. The room has the following dimensions: length = 20 ft, width = 20 ft; and height = 9 ft. This example assumes that the roof penetrations for the supply and return air ducts are well sealed and there are no other roof penetrations. The supply side of the rooftop unit is ducted to a VAV terminal control unit serving the room in question. A return air grille conducts air to a common ceiling return air plenum. The return air is then directed to the rooftop unit through a short rectangular return air duct.

The following three sound paths are to be examined:

- Path 1.** Fan airborne supply air sound that enters the room from the supply air system through the ceiling diffuser
- Path 2.** Fan airborne supply air sound that breaks out through the wall of the main supply air duct into the plenum space above the room
- Path 3.** Fan airborne return air sound that enters the room from the inlet of the return air duct

The sound power levels associated with the supply air and return air sides of the fan in the rooftop unit are specified by the manufacturer as follows:

Path 1 in Example 8

No. Description	Octave Band Center Frequency, Hz						
	63	125	250	500	1000	2000	4000
1 Fan—Supply air, 7000 cfm, 2.5 in. s.p.	92	86	80	78	78	74	71
3 22 in. wide (dia.) unlined radius elbow	0	-1	-2	-3	-3	-3	-3
Sum with noise reduction values	92	85	78	75	75	71	68
4 90° bend without turning vanes, 12 in. radius	56	54	51	47	42	37	29
Sum sound power levels	92	85	78	75	75	71	68
5 22 in. dia. by 44 in. high pressure silencer	-4	-7	-19	-31	-38	-38	-27
Sum with noise reduction values	88	78	59	44	37	33	41
6 Regenerated noise from above silencer	68	79	69	60	59	59	55
Sum sound power levels	88	82	69	60	59	59	55
7 22 in. dia. by 8 ft unlined circular duct	0	0	0	0	0	0	0
10 Branch pwr. div., M-22 in. dia., B-10 in. dia.	-8	-8	-8	-8	-8	-8	-8
Sum with noise reduction values	80	74	61	52	51	51	47
11 Duct 90° branch takeoff, 2 in. radius	56	53	50	47	43	37	31
Sum sound power levels	80	74	61	53	52	51	47
12 10 in. dia. by 6 ft unlined circular duct	0	0	0	0	0	0	0
13 Terminal volume register unit (gen. attn.)	0	-5	-10	-15	-15	-15	-15
14 10 in. dia. by 2 ft unlined circular duct	0	0	0	0	0	0	0
15 10 in. wide (dia.) unlined radius elbow	0	0	-1	-2	-3	-3	-3
Sum with noise reduction values	80	69	50	36	34	33	29
16 90° bend without turning vanes, 2 in. radius	49	45	41	37	31	24	16
Sum sound power levels	80	69	51	40	36	34	29
17 10 in. dia. diffuser end ref. loss	-16	-10	-6	-2	-1	0	0
Sum with noise reduction values	64	59	45	38	35	34	29
18 15 by 15 in. rectangular diffuser	31	36	39	40	39	36	30
Sum sound power levels	64	59	46	42	40	38	33
19 ASHRAE room correction, 1 ind. sound source	-5	-6	-7	-8	-9	-10	-11
Sound pressure levels—receiver room	59	53	39	34	31	28	22
Sound pressure levels—receiver room (without regenerated noise considered)	59	49	27	9	1	-3	4

Path 2 in Example 8

No. Description	63	125	250	500	1000	2000	4000
1 Fan—Supply air, 7000 cfm, 2.5 in. s.p.	92	86	80	78	78	74	71
3 22 in. wide (dia.) unlined radius elbow	0	-1	-2	-3	-3	-3	-3
Sum with noise reduction values	92	85	78	75	75	71	68
4 90° bend without turning vanes, 12 in. radius	56	54	51	47	42	37	29
Sum sound power levels	92	85	78	75	75	71	68
5 22 in. dia. by 44 in. high pressure silencer	-4	-7	-19	-31	-38	-38	-27
Sum with noise reduction values	88	78	59	44	37	33	41
6 Regenerated noise from above silencer	68	79	69	60	59	59	55
Sum sound power levels	88	82	69	60	59	59	55
7 22 in. dia. by 8 ft unlined circular duct	0	0	0	0	0	0	0
8 Branch pwr. div., M-22 in. dia., B-22 in. dia.	-1	-1	-1	-1	-1	-1	-1
Sum with noise reduction values	87	81	68	59	58	58	54
9 Duct 90° branch takeoff, 2 in. radius	63	60	57	54	50	44	34
Sum sound power levels	87	81	68	60	59	58	54
20 22 in. dia. by 20 ft, 26 ga. duct breakout	-29	-29	-21	-11	-9	-7	-5
21 2 ft by 4 ft by 5/8 in. lay-in ceiling	-10	-13	-11	-14	-19	-23	-24
22 Line source—Medium-dead room	-6	-5	-4	-6	-7	-8	-9
Sound pressure levels—receiver room	42	34	32	29	24	20	16
Sound pressure levels—receiver room (without regenerated noise considered)	42	30	22	12	1	-6	2

Path 3 in Example 8

No. Description	63	125	250	500	1000	2000	4000
2 Fan—Return air, 7000 cfm, 2.5 in. s.p.	82	79	80	78	78	74	71
23 32 in. wide lined square elbow w/o turning vanes	-1	-6	-11	-10	-10	-10	-10
Sum with noise reduction values	81	73	69	68	68	64	61
24 90° bend w/o turning vanes; 0.5 in radius	77	73	68	62	55	48	38
Sum sound power levels	82	76	72	69	68	64	61
25 32 in. by 68 in. by 8 ft lined duct	-2	-2	-5	-15	-22	-11	-10
26 32 in. by 68 in. diffuser end ref. loss	-5	-2	-1	0	0	0	0
21 2 ft by 4 ft by 5/8 in. lay in ceiling	-10	-13	-11	-19	-19	-23	-24
27 ASHRAE room correction, 1 ind. sound source	-8	-9	-10	-11	-12	-13	-14
Sound pressure levels—receiver room	57	50	45	29	15	17	13
Sound pressure levels—receiver room (without regenerated noise considered)	56	47	42	28	15	17	13

Total Sound Pressure Levels from All Paths in Example 8

Description	63	125	250	500	1000	2000	4000
Sound pressure levels Path 1	59	53	39	34	31	28	22
Sound pressure levels Path 2	42	34	32	29	24	20	16
Sound pressure levels Path 3	57	50	45	29	15	17	13
Total sound pressure levels—All paths	61	55	46	36	32	29	23
Sound pressure levels—receiver room (without regenerated noise considered)	61	51	42	28	15	17	14

	Octave Midband Frequency, Hz						
	63	125	250	500	1000	2000	4000
Rooftop supply air, 7000 cfm at 2.5 in. of water	92	86	80	78	78	74	71
Rooftop return air, 7000 cfm at 2.5 in. of water	82	79	73	69	69	67	59

Solution:

Paths 1 and 2 are associated with the supply air side of the system. Figure 35 shows the part of the supply air system associated with the receiver room. The main duct is a 22 in. diameter, 26 ga, unlined, round sheet metal duct. The flow volume in the main duct is 7000 cfm. The silencer after the radiused elbow is a 22 in. diameter by 44 in. long, high-pressure, circular silencer.

The branch junction 8 ft from the silencer is a 45° wye. The branch duct between the main duct and the VAV control unit is a 10 in. diameter, unlined, round sheet metal duct. The flow volume in the branch duct is 800 cfm.

The straight duct section between the VAV control unit and the diffuser is a 10 in. diameter, unlined, round sheet metal duct. The diffuser

is 15 by 15 in. Assume a typical distance between the diffuser and a listener in the room is 5 ft.

The duct breakout sound is associated with the main duct, which has a length of 20 ft running over the room. The ceiling is comprised of 2 ft by 4 ft by 5/8 in. lay-in ceiling tiles with a surface weight of 0.6 to 0.7 lb/ft². The ceiling has integrated lighting and diffusers.

Path 3 is associated with the return air side of the system. Figure 36 shows the part of the return air system associated with the receiver room. The rectangular return air duct is lined with 2 in. thick, 3 lb/ft³ density fiberglass duct liner. For the return air path, assume the typical distance between the inlet of the return air duct and a listener is 10 ft.

A computer program performed the many calculations associated with this example. The analysis for each path begins at the rooftop unit (fan) and proceeds through the different system elements to the receiver room. The element numbers in the tables correspond to the element numbers contained in brackets in Figures 35 and 36.

The first table is associated with Path 1. The first entry in the table is the manufacturer's values for supply air fan sound power levels (1). The second entry is the sound attenuation associated with the 22 in. diameter unlined radius elbow (3). Because the next entry is

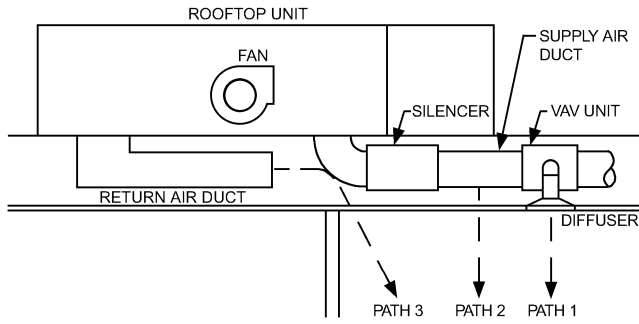

Fig. 34 Sound Paths Layout for Example 8

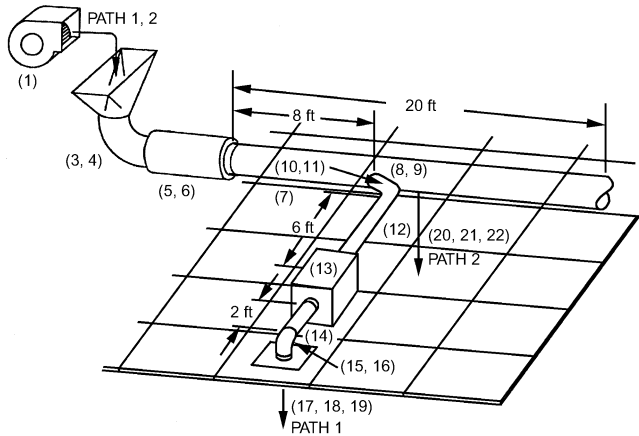

Fig. 35 Supply Air Portion Layout for Example 8

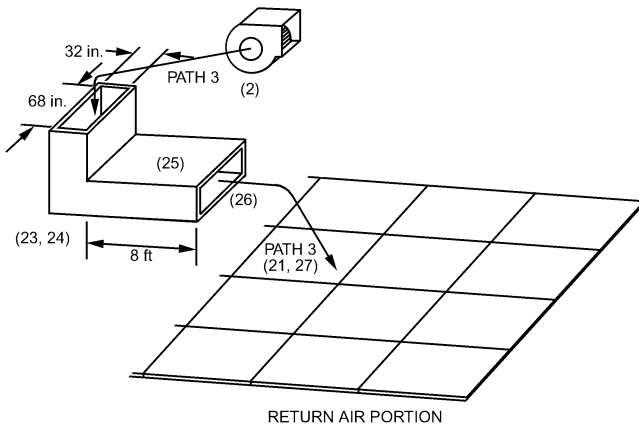

Fig. 36 Return Air Portion Layout for Example 8

associated with the regenerated sound power levels associated with the elbow (4), the results associated with the elbow attenuation must be tabulated to determine the sound power levels at the exit of the elbow.

These sound power levels and the elbow-regenerated sound power levels are then added logarithmically, which is denoted by (Log Sum) in the tables where the value in decibels equals $10 \log_{10} (10^{A/10} + 10^{B/10})$ with A and B being the values in decibels. Similarly, the dynamic insertion loss values of the duct silencer (5) and the silencer-regenerated sound power levels (6) are included in the table and tabulated.

Next, the attenuation associated with the 8 ft section of 22 in. diameter duct (7) and the branch power division (10) associated with sound

propagation in the 10 in. diameter branch duct are included in the table. After element 10, the sound power levels that exist in the branch duct after the branch takeoff are calculated so that the regenerated sound power levels (11) in the branch duct associated with the branch takeoff can be logarithmically added to the results.

Next, the sound attenuation values associated with the 6 ft section of 10 in. diameter unlined duct (12), the terminal volume regulation unit (13), the 2 ft section of 10 in. diameter unlined duct (14), and 10 in. diameter radius elbow (15) are included in the table. The sound power levels at the exit of the elbow are then calculated so that the regenerated sound power levels (16) associated with the elbow can be logarithmically added to the results. The diffuser end reflection loss (17) and the diffuser-regenerated sound power levels (18) are included in the table. The sound power levels tabulated after element 18 are the sound power levels at the diffuser in the receiver room. Note that the end reflection from a duct in free space and flush with a suspended acoustical ceiling are assumed to be the same.

The final entry in the table is the “room correction,” which converts the sound power levels at the diffuser to their corresponding sound pressure levels at the point of interest in the receiver room.

Elements 1 through 7 in Path 2 are the same as Path 1. Elements 8 and 9 are associated with the branch power division (8) and the corresponding regenerated sound power levels (9) associated with sound that propagates down the main duct beyond the duct branch. The next three entries in the table are the sound transmission loss associated with the duct breakout sound (20); the sound transmission loss associated with the ceiling (21), which considers the integrated lighting and diffuser system, including the return air openings; and the “room correction” (22), converting the sound power levels at the ceiling to corresponding sound pressure levels in the room. Although not specifically considered in this example, noise radiated by a VAV terminal unit can be a significant source. Consult the manufacturer for both radiated and discharge sound data.

The first element in Path 3 is the manufacturer’s values for return air fan sound power levels (2). The next two elements are the sound attenuation associated with a 32 in. wide lined square elbow without turning vanes (23) and the regenerated sound power levels associated with the square elbow (24). The final four elements are the insertion loss associated with a 32 in. by 68 in. by 8 ft rectangular sheet metal duct with 2 in. thick, 3 lb/ft³ fiberglass duct lining (26); the diffuser end reflection loss (27), the transmission loss through the ceiling (21), which considers the integrated lighting and diffuser system, including the return air openings; and the room correction (27), converting the sound power levels at the ceiling to corresponding sound pressure levels in the room.

The total sound pressure levels in the receiver room from the three paths are obtained by logarithmically adding the individual sound pressure levels associated with each path. From the total sound pressure levels for all three paths, the NC value in the room is NC 42, and the RC value is RC 34(R-H), which is a combination of lower-frequency rumble and higher-frequency hiss.

If the regenerated noise from airflow through the ductwork, silencer, and diffuser is not taken into consideration, the NC value in the room is NC 42, and the RC value is RC 26(R-H). Although the calculation procedure is simplified, the typically higher-frequency regenerated noise is not accounted for in the overall ratings, especially in the RC value; its numeric magnitude is often set by the higher-frequency noise contribution. At a minimum, the self-noise or regenerated noise of the silencers and outlet or inlet devices such as grilles, registers, and diffusers should be considered along with the attenuation provided by the duct elements and dynamic insertion loss of the silencers.

VIBRATION ISOLATION AND CONTROL

Mechanical vibration and vibration-induced noise are often major sources of occupant complaints in modern buildings. Lightweight construction in new buildings increases susceptibility to vibration and vibration-related problems. Increased interest in energy conservation has resulted in many new buildings being designed with variable air volume systems. This often results in mechanical equipment being located in penthouses on the roof, in the use of roof-mounted HVAC units, and in locating mechanical

equipment rooms on intermediate-level floors, with more mechanical equipment located in a building and/or adjacent to or above occupied areas.

Occupant complaints associated with building vibration typically take one or more of three forms:

- The level of vibration perceived by building occupants is of sufficient magnitude to cause concern or alarm;
- Vibration energy from mechanical equipment, which is transmitted to the building structure, is transmitted to various parts of the building and then is radiated as structure-borne noise; and
- The vibration present in a building may interfere with proper operation of sensitive equipment or instrumentation.

The following sections present basic information to properly select and specify vibration isolators and to analyze and correct field vibration problems.

EQUIPMENT VIBRATION

Any vibrating, reciprocating, or rotating equipment should be mounted such that it does not transmit significant levels of vibration into the surrounding or supporting structure. Vibrations transmitted via machine mounts or attached piping, ductwork, or electrical connections can result in vibrating walls, floors, and/or ceilings, which in turn radiate sound and/or vibration. Hence, it is important to provide vibration isolation for all attachments to a vibrating machine, including structural mounts, cooling or drainage pipe connections, exhaust air ductwork, and electrical connections, among others.

Vibration can be isolated or reduced to a fraction of the original force with resilient mounts between the equipment and the supporting structure, provided that the supporting structure has sufficient stiffness and mass. **Isolation efficiency** is the percentage of vibratory force transmitted to the support structure. **Figure 37** shows that 90% efficiency results in 10% of the vibration force being transmitted. In this case, the magnitude of transmission to the building is a function of the magnitude of the vibration force. **Figure 38** shows the effect of different efficiency levels.

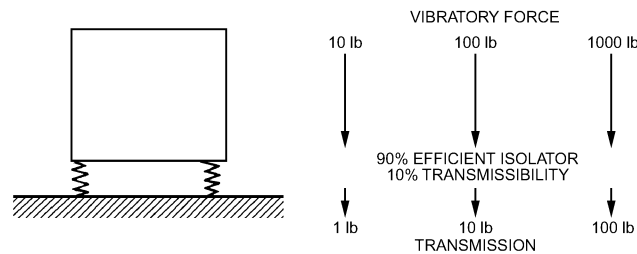

Fig. 37 Transmission to Structure Varies as Function of Magnitude of Vibration Force

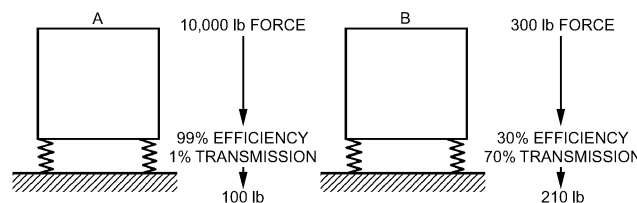

Fig. 38 Interrelationship of Equipment Vibration, Isolation Efficiency, and Transmission

VIBRATION CRITERIA

Vibration criteria can be specified relative to three areas: (1) human response to vibration, (2) vibration levels associated with potential damage to sensitive equipment in a building, and (3) vibration severity of a vibrating machine. **Figure 39** and **Table 40** present recommended acceptable vibration criteria for vibration in a building structure (Ungar et al. 1990). The vibration values in **Figure 39** are measured by vibration transducers (usually accelerometers) placed on the building structure near vibrating equipment or in areas containing occupants or sensitive equipment. The occupant vibration criteria are based on guidelines specified by ANSI *Standard* S3.29, and ISO *Standard* 2631-2. For sensitive equipment, acceptable vibration values specified by equipment manufacturers should be used.

If acceptable vibration values are not available from equipment manufacturers, the values specified in **Figure 40** can be used. This figure gives recommended equipment vibration severity ratings based on measured RMS velocity values (IRD 1988). The vibration values in **Figure 40** are measured by vibration transducers (usually accelerometers) mounted directly on equipment, equipment structures, or bearing caps. Vibration levels measured on equipment and equipment components can be affected by equipment unbalance, misalignment of equipment components, and resonance interaction between a vibrating piece of equipment and the floor on which it is placed. If a piece of equipment is balanced within acceptable tolerances and excessive vibration levels still exist, the equipment and installation should be checked for possible resonant conditions. **Table 41** gives maximum allowable RMS velocity levels for selected pieces of equipment.

Vibration levels measured on equipment structures should be in the “Good” region or below in **Figure 40**. Machine vibration levels

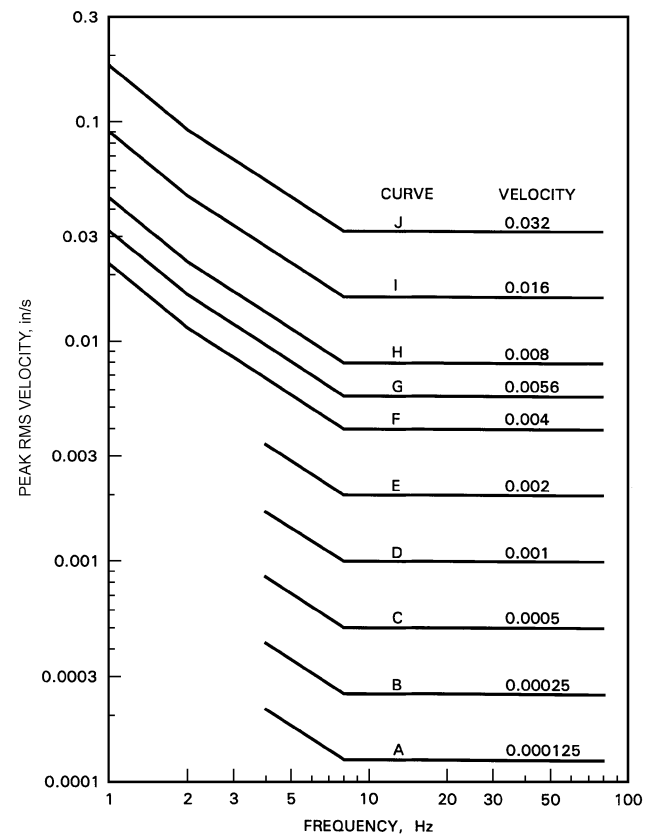

Fig. 39 Building Vibration Criteria for Vibration Measured on Building Structure

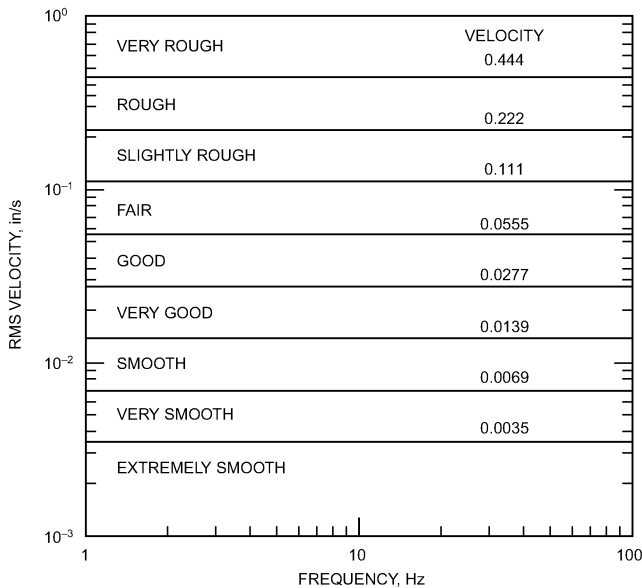

Fig. 40 Equipment Vibration Severity Rating for Vibration Measured on Equipment Structure or Bearing Caps

Table 40 Equipment Vibration Criteria

Human Comfort	Time of Day	Curve ^a
Workshops	All	J
Office areas	All ^b	I
Residential (good environmental standards)	0700-2200 ^b	H
	2200-0700 ^b	G
Hospital operating rooms and critical work areas	All	F
Equipment Requirements		Curve ^a
Computer areas		H
Bench microscopes up to 100× magnification; laboratory robots		F
Bench microscopes up to 400× magnification; optical and other precision balances; coordinate measuring machines; metrology laboratories; optical comparators; microelectronics manufacturing equipment—Class A ^c		E
Microsurgery, eye surgery, neurosurgery; bench microscopes at magnification greater than 400 ×; optical equipment on isolation tables; microelectronic manufacturing equipment—Class B ^c		D
Electron microscopes up to 30,000 × magnification; microtomes; magnetic resonance imagers; microelectronics manufacturing equipment—Class C ^c		C
Electron microscopes at magnification greater than 30,000 ×; mass spectrometers; cell implant equipment; microelectronics manufacturing equipment—Class D ^c		B
Unisolated laser and optical research systems; microelectronics manufacturing equipment—Class E ^c		A

^aSee Figure 39 for corresponding curves.

^bIn areas where individuals are sensitive to vibration, use curve H.

^cClasses of microelectronics manufacturing equipment:

- Class A: Inspection, probe test, and other manufacturing support equipment.
- Class B: Aligners, steppers, and other critical equipment for photolithography with line widths of 3 mm or more.
- Class C: Aligners, steppers, and other critical equipment for photolithography with line widths of 1 mm.
- Class D: Aligners, steppers, and other critical equipment for photolithography with line widths of 0.5 mm; includes electron-beam systems.
- Class E: Aligners, steppers, and other critical equipment for photolithography with line widths of 0.25 mm; includes electron-beam systems.

Table 41 Maximum Allowable RMS Velocity Levels

Equipment	Allowable rms Velocity, in/s
Pumps	0.13
Centrifugal compressors	0.13
Fans (vent sets, centrifugal, axial)	0.09

in the “Fair” or “Slightly Rough” regions may indicate potential problems requiring maintenance attention. Machines with vibration levels in these regions should be monitored to ensure problems do not arise. Machine vibration levels in the “Rough” and “Very Rough” regions indicate a potentially serious problem; immediate action should be taken to identify and correct the problem.

SPECIFICATION OF VIBRATION ISOLATORS

Vibration isolators must be selected not only to provide required isolation efficiency but also to compensate for floor stiffness. Longer floor spans are more flexible and thus more easily set into vibration. Floor spans, equipment operating speeds, equipment power, damping, and other factors are considered in [Table 42](#), Selection Guide for Vibration Isolation.

In specifying isolator deflection rather than isolation efficiency or transmissibility, a designer can compensate for floor stiffness and building resonances by selecting isolators that have more deflection than the supporting floor. To apply the information from [Table 42](#), base type, isolator type, and minimum deflection columns are added to the equipment schedule. These isolator specifications are then incorporated into mechanical specifications for the project.

The minimum deflections listed in [Table 42](#) are based on the experience of acoustical and mechanical consultants and vibration control manufacturers. Recommended isolator type, base type, and minimum static deflection are reasonable and safe recommendations for 70 to 80% of HVAC equipment installations. The selections are based on concrete equipment room floors 4 to 12 in. thick with typical floor stiffness. The type of equipment, proximity to noise-sensitive areas, and the type of building construction may alter these choices.

The following method develops isolator selection for specific applications:

1. Use [Table 42](#) for floors specifically designed to accommodate mechanical equipment.
2. Use recommendations from the 20 ft span column for equipment on ground-supported slabs adjacent to noise-sensitive areas.
3. For roofs and floors constructed with open web joists; thin, long span slabs; wooden construction; and any unusual light construction, evaluate all equipment weighing more than 300 lb to determine the additional deflection of the structure caused by the equipment. Isolator deflection should be 15 times the additional deflection or the deflection shown in [Table 42](#), whichever is greater. If the required spring isolator deflection exceeds commercially available products, consider air springs, stiffen the supporting structure, or change the equipment location.
4. When mechanical equipment is adjacent to noise-sensitive areas, isolate mechanical equipment room noise.

INTERNAL VERSUS EXTERNAL ISOLATION

Vibration isolators are most effective if the isolator base is attached directly to the building structure at a support point possessing high stiffness compared to the stiffness of the isolator. In many cases, the vibrating equipment (e.g., air-handling units) can be effectively isolated with internal vibration isolators, where only the moving parts (e.g., fan/motor assembly) are supported by the isolators. This approach can reduce the load supported by the isolators

and thus can reduce the cost of isolation. The primary advantage of internal isolation other than reduced cost is the reduction of vibration and structure-borne noise into the air-handling unit housing. Disadvantages of internal isolation can include the following:

- The isolator is often not easily visible in the field to verify that it is functioning properly.
- The isolator support point may be near the middle of a beam, which often provides inadequate stiffness for optimum performance of the isolator.
- Isolator short-circuiting (caused by the horizontal thrust of the fan during normal operation) can significantly degrade the internal vibration isolation of internal seismic spring mountings.

It is possible to use both internal and external vibration isolation in the same air-handling unit, but isolator stiffness selection must avoid resonances at or near normal fan rotational speeds. When both internal and external vibration isolation are used in the same unit, there are multiple resonance frequencies to consider. If the fan operates at or near one of these frequencies, vibration levels could become excessive. The probability of such an interaction increases significantly if the fan is driven by a variable-frequency drive. Implementing both internal and external vibration isolation on the same unit should only be attempted with the guidance of an experienced vibration consultant.

ISOLATION OF VIBRATION AND NOISE IN PIPING SYSTEMS

All piping systems have mechanical vibration generated by the equipment and impeller-generated and flow-induced vibration and noise, which is transmitted by the pipe wall and the water column. In addition, equipment supported by vibration isolators exhibits some motion from pressure thrusts during operation. Vibration isolators have even greater movement during start-up and shutdown as equipment vibration passes through the isolators' resonance frequency. The piping system must be flexible enough to (1) reduce vibration transmission along the connected piping, (2) permit equipment movement without reducing the performance of vibration isolators, and (3) accommodate equipment movement or thermal movement of the piping at connections without imposing undue strain on the connections and equipment.

Flow noise and vibration in piping can be reintroduced by turbulence, sharp pressure drops, and entrained air; however, this can be minimized by sizing pipe so that velocities are 4 fps maximum for pipe 2 in. and smaller and using a pressure drop limitation of 4 ft of water per 100 ft of pipe length with a maximum velocity of 10 fps for larger pipe sizes. Care should be taken not to exceed these limits.

Resilient Pipe Hangers and Supports

Resilient pipe hangers and supports may be used to prevent vibration and noise transmission from the piping system to the building structure and to provide flexibility in the piping.

Suspended Piping. Isolation hangers described in Note 25 of [Table 42](#) should be used for all piping in equipment rooms and up to 50 ft from vibrating equipment. To avoid reducing the effectiveness of equipment isolators, at least the first three hangers from the equipment should provide the same deflection as the equipment isolators, with a maximum limitation of 2 in. deflection; the remaining hangers should be spring or combination spring and rubber with 0.75 in. deflection.

The first two hangers adjacent to the equipment should be the positioning or precompressed type, to prevent load transfer to the equipment flanges when the piping system is filled. The positioning hanger aids in installing large pipe, and many engineers specify this type for all isolated pipe hangers for piping 8 in. and larger.

Piping over 2 in. in diameter and piping suspended below or near noise-sensitive areas should be hung with isolation hangers. Hangers adjacent to noise-sensitive areas should be the spring and rubber combination Type 3.

Floor-Supported Piping. Floor supports for piping in equipment rooms and adjacent to isolated equipment should use vibration isolators as described in [Table 42](#). They should be selected according to the guidelines for hangers. The first two adjacent floor supports should be the restrained spring type, with a blocking feature that prevents load transfer to equipment flanges as the piping is filled or drained. Where pipe is subjected to large thermal movement, a slide plate (PTFE, graphite, or steel) should be installed on top of the isolator, and a thermal barrier should be used when rubber products are installed directly beneath steam or hot water lines.

Riser Supports, Anchors, and Guides. Many piping systems have anchors and guides, especially in the risers, to permit expansion joints, bends, or pipe loops to function properly. Anchors and guides are designed to eliminate or limit (guide) pipe movement and must be rigidly attached to the structure; this is inconsistent with the resiliency required for effective isolation. The engineer should try to locate the pipe shafts, anchors, and guides in noncritical areas, such as next to elevator shafts, stairwells, and toilets, rather than adjoining noise-sensitive areas. Where concern about vibration transmission exists, some type of vibration isolation support or acoustical support is required for the pipe support, anchors, and guides.

Because anchors or guides must be rigidly attached to the structure, the isolator cannot deflect in the sense previously discussed, and the primary interest is that of an acoustical barrier. Heavy-duty rubber pads that can accommodate large loads with minimal deflection can provide such an acoustical barrier. [Figure 41](#) shows some arrangements for resilient anchors and guides. Similar resilient supports can be used for the pipe.

Resilient supports for pipe, anchors, and guides can attenuate noise transmission, but they do not provide the resiliency required to isolate vibration. Vibration must be controlled in an anchor guide system by designing flexible pipe connectors and resilient isolation hangers or supports.

Completely spring-isolated riser systems that eliminate the anchors and guides have been used successfully in many instances and give effective vibration and acoustical isolation. In this type of isolation system, the springs are sized to accommodate thermal growth as well as to guide and support the pipe. These systems provide predictable load transfer because of thermal expansion and contraction, but require careful engineering to accommodate movements encountered not only in the riser but also in the branch takeoff to avoid overstressing the piping.

Piping Penetrations. HVAC systems typically have piping that must penetrate floors, walls, and ceilings. If such penetrations are not properly treated, they provide a path for airborne noise, which can destroy the acoustical integrity of the occupied space. Seal the openings in pipe sleeves between noisy areas, such as equipment rooms, and occupied spaces with an acoustical barrier such as fibrous material and resilient acoustical caulking, or with engineered pipe penetration seals as shown in [Figure 42](#).

Flexible Pipe Connectors

Flexible pipe connectors (1) provide piping flexibility to permit isolators to function properly, (2) protect equipment from strain due to misalignment and expansion or contraction of piping, and (3) attenuate noise and vibration transmission along the piping ([Figure 43](#)). Connectors are available in two configurations: (1) hose type, a straight or slightly corrugated wall construction of either rubber or metal; and (2) the arched or expansion joint type, a short-length connector with one or more large radius arches, of rubber, PTFE, or metal. Metal expansion joints are acoustically ineffective and are seldom successfully used for vibration and sound isolation in HVAC

Table 42 Selection Guide for Vibration Isolation

Equipment Type		Horsepower and Other		RPM		Equipment Location (Note 1)										Reference Notes		
						Slab on Grade						Floor Span						
						Base Type	Isola-tor Type	Min. Defl., in.	Base Type	Isola-tor Type	Min. Defl., in.	Up to 20 ft		20 to 30 ft			30 to 40 ft	
												Base Type	Isola-tor Type	Min. Defl., in.	Base Type		Isola-tor Type	Min. Defl., in.
Refrigeration Machines and Chillers																		
Reciprocating	All	All	A	2	0.25	A	4	0.75	A	4	1.50	A	4	2.50	2,3,12			
Centrifugal, screw	All	All	A	1	0.25	A	4	0.75	A	4	1.50	A	4	1.50	2,3,4,12			
Open centrifugal	All	All	C	1	0.25	C	4	0.75	C	4	1.50	C	4	1.50	2,3,12			
Absorption	All	All	A	1	0.25	A	4	0.75	A	4	1.50	A	4	1.50				
Air Compressors and Vacuum Pumps																		
Tank-mounted horiz.	Up to 10	All	A	3	0.75	A	3	0.75	A	3	1.50	A	3	1.50	3,15			
	15 and up	All	C	3	0.75	C	3	0.75	C	3	1.50	C	3	1.50	3,15			
Tank-mounted vert.	All	All	C	3	0.75	C	3	0.75	C	3	1.50	C	3	1.50	3,15			
Base-mounted	All	All	C	3	0.75	C	3	0.75	C	3	1.50	C	3	1.50	3,14,15			
Large reciprocating	All	All	C	3	0.75	C	3	0.75	C	3	1.50	C	3	1.50	3,14,15			
Pumps																		
Close-coupled	Up to 7.5	All	B	2	0.25	C	3	0.75	C	3	0.75	C	3	0.75	16			
	10 and up	All	C	3	0.75	C	3	0.75	C	3	1.50	C	3	1.50	16			
Large inline	5 to 25	All	A	3	0.75	A	3	1.50	A	3	1.50	A	3	1.50				
	30 and up	All	A	3	1.50	A	3	1.50	A	3	1.50	A	3	2.50				
End suction and split case	Up to 40	All	C	3	0.75	C	3	0.75	C	3	1.50	C	3	1.50	16			
	50 to 125	All	C	3	0.75	C	3	0.75	C	3	1.50	C	3	2.50	10,16			
	150 and up	All	C	3	0.75	C	3	1.50	C	3	2.50	C	3	3.50	10,16			
Cooling Towers																		
All	Up to 300	A	1	0.25	A	4	3.50	A	4	3.50	A	4	3.50	5,8,18				
	301 to 500	A	1	0.25	A	4	2.50	A	4	2.50	A	4	2.50	5,18				
	500 and up	A	1	0.25	A	4	0.75	A	4	0.75	A	4	1.50	5,18				
Boilers (Fire-tube)																		
All	All	A	1	0.25	B	4	0.75	B	4	1.50	B	4	2.50	4				
Axial Fans, Fan Heads, Cabinet Fans, Fan Sections																		
Up to 22 in. diameter	All	All	A	2	0.25	A	3	0.75	A	3	0.75	C	3	0.75	4,9			
24 in. diameter and up	Up to 2 in. s.p.	Up to 300	B	3	2.50	C	3	3.50	C	3	3.50	C	3	3.50	9			
		300 to 500	B	3	0.75	B	3	1.50	C	3	2.50	C	3	2.50	9			
		501 and up	B	3	0.75	B	3	1.50	B	3	1.50	B	3	1.50	9			
	2.1 in. s.p. and up	Up to 300	C	3	2.50	C	3	3.50	C	3	3.50	C	3	3.50	3,9			
		300 to 500	C	3	1.50	C	3	1.50	C	3	2.50	C	3	2.50	3,8,9			
		501 and up	C	3	0.75	C	3	1.50	C	3	1.50	C	3	2.50	3,8,9			
Centrifugal Fans																		
Up to 22 in. diameter	All	All	B	2	0.25	B	3	0.75	B	3	0.75	C	3	1.50	9,19			
24 in. diameter and up	Up to 40	Up to 300	B	3	2.50	B	3	3.50	B	3	3.50	B	3	3.50	8,19			
		300 to 500	B	3	1.50	B	3	1.50	B	3	2.50	B	3	2.50	8,19			
		501 and up	B	3	0.75	B	3	0.75	B	3	0.75	B	3	1.50	8,19			
	50 and up	Up to 300	C	3	2.50	C	3	3.50	C	3	3.50	C	3	3.50	2,3,8,9,19			
		300 to 500	C	3	1.50	C	3	1.50	C	3	2.50	C	3	2.50	2,3,8,9,19			
		501 and up	C	3	1.00	C	3	1.50	C	3	1.50	C	3	2.50	2,3,8,9,19			
Propeller Fans																		
Wall-mounted	All	All	A	1	0.25	A	1	0.25	A	1	0.25	A	1	0.25				
Roof-mounted	All	All	A	1	0.25	A	1	0.25	B	4	1.50	D	4	1.50				
Heat Pumps																		
All	All	All	A	3	0.75	A	3	0.75	A	3	0.75	A/D	3	1.50				
Condensing Units																		
All	All	All	A	1	0.25	A	4	0.75	A	4	1.50	A/D	4	1.50				
Packaged AH, AC, H and V Units																		
All	Up to 10	All	A	3	0.75	A	3	0.75	A	3	0.75	A	3	0.75	19			
	15 and up to 4 in. s.p.	Up to 300	A	3	0.75	A	3	3.50	A	3	3.50	C	3	3.50	2,4,8,19			
		301 to 500	A	3	0.75	A	3	2.50	A	3	2.50	A	3	2.50	4,19			
		501 and up	A	3	0.75	A	3	1.50	A	3	1.50	A	3	1.50	4,19			
	15 and up, 4 in. s.p. and up	Up to 300	B	3	0.75	C	3	3.50	C	3	3.50	C	3	3.50	2,3,4,8,9			
		301 to 500	B	3	0.75	C	3	1.50	C	3	2.50	C	3	2.50	2,3,4,9			
		501 and up	B	3	0.75	C	3	1.50	C	3	1.50	C	3	2.50	2,3,4,9			
Packaged Rooftop Eqmt.																		
All	All	All	A/D	1	0.25	D	3	0.75	See Reference Note No: 17				5,6,8,17					
Ducted Rotating Equipment																		
Small fans, fan-powered boxes	Up to 600 cfm	All	A	3	0.50	A	3	0.50	A	3	0.50	A	3	0.50	7			
	601 cfm and up	All	A	3	0.75	A	3	0.75	A	3	0.75	A	3	0.75	7			
Engine-Driven Generators																		
All	All	All	A	3	0.75	C	3	1.50	C	3	2.50	C	3	3.50	2,3,4			

Base Types:

- A. No base, isolators attached directly to equipment (Note 27)
- B. Structural steel rails or base (Notes 28 and 29)
- C. Concrete inertia base (Note 30)
- D. Curb-mounted base (Note 31)

Isolator Types:

1. Pad, rubber, or glass fiber (Notes 20 and 21)
2. Rubber floor isolator or hanger (Notes 20 and 25)
3. Spring floor isolator or hanger (Notes 22, 23, and 25)
4. Restrained spring isolator (Notes 22 and 24)
5. Thrust restraint (Note 26)

Notes for Table 42: Selection Guide for Vibration Isolation

These notes are keyed to the column titled *Reference Notes* in Table 42 and to other reference numbers throughout the table. Although the guide is conservative, cases may arise where vibration transmission to the building is still excessive. If the problem persists after all short circuits have been eliminated, it can almost always be corrected by increasing isolator deflection, using low-frequency air springs, changing operating speed, improving rotating component balancing, or, as a last resort, changing floor frequency by stiffening or adding more mass. The assistance of a qualified vibration consultant can be very useful in resolving these problems.

Note 1. Isolator deflections shown are based on a reasonably expected floor stiffness according to floor span and class of equipment. Certain spaces may dictate higher levels of isolation. For example, bar joist roofs may require a static deflection of 1.5 in. over factories, but 2.5 in. over commercial office buildings.

Note 2. For large equipment capable of generating substantial vibratory forces and structure-borne noise, increase isolator deflection, if necessary, so isolator stiffness is less than one-tenth the stiffness of the supporting structure.

Note 3. For noisy equipment adjoining or near noise-sensitive areas, see the section on Mechanical Equipment Room Sound Isolation.

Note 4. Certain designs cannot be installed directly on individual isolators (Type A), and the equipment manufacturer or a vibration specialist should be consulted on the need for supplemental support (Base Type).

Note 5. Wind load conditions must be considered. Restraint can be achieved with restrained spring isolators (Type 4), supplemental bracing, snubbers, or limit stops. Also see [Chapter 54, Seismic and Wind Resistant Design](#).

Note 6. Certain types of equipment require a curb-mounted base (Type D). Airborne noise must be considered.

Note 7. See section on Resilient Pipe Hangers and Supports for hanger locations adjoining equipment and in equipment rooms.

Note 8. To avoid isolator resonance problems, select isolator deflection so that resonance frequency is 40% or less of the lowest normal operating speed of equipment (see [Chapter 7 in the ASHRAE Handbook—Fundamentals](#)).

Note 9. To limit undesirable movement, thrust restraints (Type 5) are required for all ceiling-suspended and floor-mounted units operating at 2 in. of water or more total static pressure.

Note 10. Pumps over 75 hp may need extra mass and restraints.

Note 11. See text for full discussion.

Isolation for Specific Equipment

Note 12. Refrigeration Machines: Large centrifugal, hermetic, and reciprocating refrigeration machines may generate very high noise levels; special attention is required when such equipment is installed in upper-story locations or near noise-sensitive areas. If equipment is located near extremely noise-sensitive areas, follow the recommendations of an acoustical consultant.

Note 13. Compressors: The two basic reciprocating compressors are (1) single- and double-cylinder vertical, horizontal or L-head, which are usually air compressors; and (2) Y, W, and multihead or multicylinder air and refrigeration compressors. Single- and double-cylinder compressors generate high vibratory forces requiring large inertia bases (Type C) and are generally not suitable for upper-story locations. If such equipment must be installed in an upper-story location or at-grade location near noise-sensitive areas, the expected maximum unbalanced force data must be obtained from the equipment manufacturer and a vibration specialist consulted for design of the isolation system.

Note 14. Compressors: When using Y, W, and multihead and multicylinder compressors, obtain the magnitude of unbalanced forces from the equipment manufacturer so the need for an inertia base can be evaluated.

Note 15. Compressors: Base-mounted compressors through 5 hp and horizontal tank-type air compressors through 10 hp can be installed directly on spring isolators (Type 3) with structural bases (Type B) if required, and compressors 15 to 100 hp on spring isolators (Type 3) with inertia bases (Type C) weighing 1 to 2 times the compressor weight.

Note 16. Pumps: Concrete inertia bases (Type C) are preferred for all flexible-coupled pumps and are desirable for most close-coupled pumps, although steel bases (Type B) can be used. Close-coupled pumps should not be installed directly on individual isolators (Type A) because the impeller usually overhangs the motor support base, causing the rear mounting to be in tension. The primary requirements for Type C bases are strength and shape to accommodate base elbow supports. Mass is not usually a factor, except for pumps over 75 hp, where extra mass helps limit excess movement due to starting torque and forces. Concrete bases (Type C) should be designed for a thickness of one-tenth the longest dimension with minimum thickness as follows: (1) for up to 30 hp, 6 in.; (2) for 40 to 75 hp, 8 in.; and (3) for 100 hp and up, 12 in.

Pumps over 75 hp and multistage pumps may exhibit excessive motion at start-up (“heaving”); supplemental restraining devices can be installed if necessary. Pumps over 125 hp may generate high starting forces; a vibration specialist should be consulted.

Note 17. Packaged Rooftop Air-Conditioning Equipment: This equipment is usually on lightweight structures that are susceptible to sound and vibration transmission. The noise problem is further compounded by curb-mounted equipment, which requires large roof openings for supply and return air.

The table shows Type D vibration isolator selections for all spans up to 20 ft, but extreme care must be taken for equipment located on spans of over 20 ft, especially if construction is open web joists or thin, lightweight slabs. The recommended procedure is to determine the additional deflection caused by equipment in the roof. If additional roof deflection is 0.25 in. or less, the isolator should be selected for 10 times the additional roof deflection. If additional roof deflection is over 0.25 in., supplemental roof stiffening should be installed to bring the roof deflection down below 0.25 in., or the unit should be relocated to a stiffer roof position.

For mechanical units capable of generating high noise levels, mount the unit on a platform above the roof deck to provide an air gap (buffer zone) and locate the unit away from the associated roof penetration to permit acoustical treatment of ducts before they enter the building.

Some rooftop equipment has compressors, fans, and other equipment isolated internally. This isolation is not always reliable because of internal short-circuiting, inadequate static deflection, or panel resonances. It is recommended that rooftop equipment be isolated externally, as if internal isolation was not used.

Note 18. Cooling Towers: These are normally isolated with restrained spring isolators (Type 4) directly under the tower or tower dunnage. High-deflection isolators proposed for use directly under the motor-fan assembly must be used with extreme caution to ensure stability and safety under all weather conditions. See Note 5.

Note 19. Fans and Air-Handling Equipment: The following should be considered in selecting isolation systems for fans and air-handling equipment:

1. Fans with wheel diameters of 22 in. and less and all fans operating at speeds to 300 rpm do not generate large vibratory forces. For fans operating under 300 rpm, select isolator deflection so the isolator natural frequency is 40% or less than the fan speed. For example, for a fan operating at 275 rpm, $0.4 \times 275 = 110$ rpm. Therefore, an isolator natural frequency of 110 rpm or lower is required. This can be accomplished with a 3 in. deflection isolator (Type 3).
2. Flexible duct connectors should be installed at the intake and discharge of all fans and air-handling equipment to reduce vibration transmission to air duct structures.
3. Inertia bases (Type C) are recommended for all Class 2 and 3 fans and air-handling equipment because extra mass permits the use of stiffer springs, which limit heaving movements.
4. Thrust restraints (Type 5) that incorporate the same deflection as isolators should be used for all fan heads, all suspended fans, and all base-mounted and suspended air-handling equipment operating at 2 in. or more total static pressure. Restraint movement adjustment must be made under normal operational static pressures.

Vibration Isolators: Materials, Types, and Configurations

Notes 20 through 31 include figures to assist in evaluating commercially available isolators for HVAC equipment. The isolator selected for a particular application depends on the required deflection, life, cost, and compatibility with the associated structures.

RUBBER PADS (Type 1)

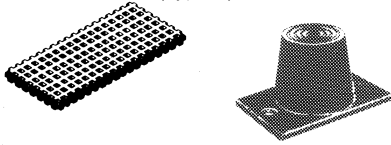

RUBBER MOUNTS (Type 2)

Note 20. Rubber isolators are available in pad (Type 1) and molded (Type 2) configurations. Pads are used in single or multiple layers. Molded isolators come in a range of 30 to 70 durometer (a measure of stiffness). Material in excess of 70 durometer is usually ineffective as an isolator. Isolators are designed for up to 0.5 in. deflection, but are used where 0.3 in. or less deflection is required. Solid rubber and composite fabric and rubber pads are also available. They provide high load capacities with small deflection and are used as noise barriers under columns and for pipe supports. These pad types work well only when they are properly loaded and the weight load is evenly distributed over the entire pad surface. Metal loading plates can be used for this purpose.

GLASS FIBER PADS (Type 1)

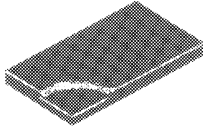

Note 21. Precompressed glass fiber isolation pads (Type 1) constitute inorganic inert material and are available in various sizes, thicknesses of 1 to 4 in., and capacities of up to 500 psi. Their manufacturing process ensures long life and a constant natural frequency of 7 to 15 Hz over the entire recommended load range. Pads are covered with an elastomeric coating to increase damping and to protect the glass fiber. Glass fiber pads are most often used for isolation of concrete foundations and floating floor construction.

SPRING ISOLATOR (Type 3)



Note 22. Steel springs are the most popular and versatile isolators for HVAC applications because they are available for almost any deflection and have a virtually unlimited life. All spring isolators should have a rubber acoustical barrier to reduce transmission of high-frequency vibration and noise that can migrate down the steel spring coil. They should be corrosion-protected if installed outdoors or in a corrosive environment. The basic types include

1. **Note 23.** *Open spring isolators* (Type 3) consist of a top and bottom load plate with an adjustment bolt for leveling. Springs should be designed with a horizontal stiffness of at least 100% of the vertical stiffness to ensure stability verified by a minimum ratio of 0.8 for the diameter divided by the deflected spring height.

RESTRAINED SPRING ISOLATOR (Type 4)

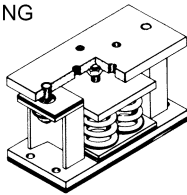

2. **Note 24.** *Restrained spring isolators* (Type 4) have hold-down bolts to limit vertical movement. They are used with (a) equipment with large variations in mass (boilers, refrigeration machines) to restrict movement and prevent strain on piping when water is removed, and (b) outdoor equipment, such as cooling towers, to prevent excessive movement because of wind load. Spring criteria should be the same as open spring isolators, and restraints should have adequate clearance so that they are activated only when a temporary restraint is needed.

3. *Housed spring isolators* consist of two telescoping housings separated by a resilient material. Although not preferred, if this type is used, care should be taken in design and installation to prevent binding and short-circuiting.

AIR SPRINGS



ROLLING LOBE



BELLOWS

Air springs can be designed for any frequency, but are economical only in applications with natural frequencies of 1.33 Hz or less (6 in. or greater deflection). They do not transmit high-frequency noise and are often used to replace high-deflection springs on problem jobs. A constant air supply (with an air dryer) is required.

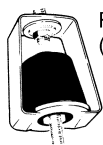

RUBBER HANGER (Type 2)

SPRING HANGER (Type 3)

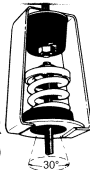

Note 25. Isolation hangers (Types 2 and 3) are used for suspended pipe and equipment and have rubber, springs, or a combination of spring and rubber elements. Criteria should be the same as for open spring isolators. To avoid short-circuiting, hangers should be designed for 20° to 35° angular hanger rod misalignment. Swivel or traveler arrangements may be necessary for connections to piping systems subject to large thermal movements.

THRUST RESTRAINT (Type 5)

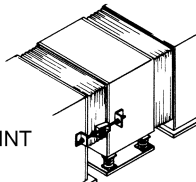

Note 26. Thrust restraints (Type 5) are similar to spring hangers or isolators and are installed in pairs to resist the thrust caused by air pressure.

DIRECT ISOLATION (Type A)

Note 27. Direct isolation (Type A) is used when equipment is unitary and rigid and does not require additional support. Direct isolation can be used with large chillers, packaged air-handling units, and air-cooled condensers. If there is any doubt that the equipment can be supported directly on isolators, use structural bases (Type B) or inertia bases (Type C), or consult the equipment manufacturer.

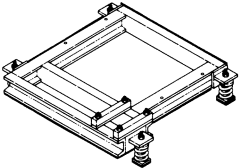
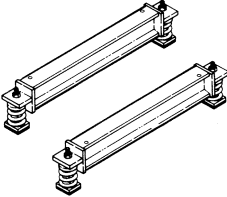
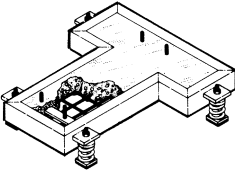
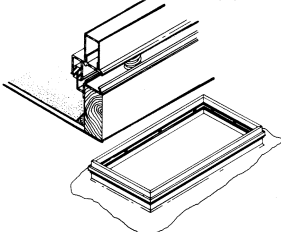
<p>STRUCTURAL BASES (Type B)</p> 	<p>Note 28. Structural bases (Type B) are used where equipment cannot be supported at individual locations and/or where some means is necessary to maintain alignment of component parts in equipment. These bases can be used with spring or rubber isolators (Types 2 and 3) and should have enough rigidity to resist all starting and operating forces without supplemental hold-down devices. Bases are made in rectangular configurations using structural members with a depth equal to one-tenth the longest span between isolators, with a minimum depth of 4 in. Maximum depth is limited to 12 in., except where structural or alignment considerations dictate otherwise.</p>
<p>STRUCTURAL RAILS (Type B)</p> 	<p>Note 29. Structural rails (Type B) are used to support equipment that does not require a unitary base or where the isolators are outside the equipment and the rails act as a cradle. Structural rails can be used with spring or rubber isolators and should be rigid enough to support the equipment without flexing. Usual practice is to use structural members with a depth one-tenth of the longest span between isolators with a minimum depth of 4 in. Maximum depth is limited to 12 in. except where structural considerations dictate otherwise.</p>
<p>CONCRETE BASES (Type C)</p> 	<p>Note 30. Concrete bases (Type C) are used where excess heaving motion may otherwise occur with spring isolators. They consist of a steel pouring form usually with welded-in reinforcing bars, provision for equipment hold-down, and isolator brackets. Like structural bases, concrete bases should be rectangular or T-shaped and, for rigidity, have a depth equal to one-tenth the longest span between isolators with a minimum of 6 in. Base depth need not exceed 12 in. unless specifically required for mass, rigidity, or component alignment.</p>
<p>CURB ISOLATION (Type D)</p> 	<p>Note 31. Curb isolation systems (Type D) are specifically designed for curb-supported rooftop equipment and have spring isolation with a watertight and airtight curb assembly. The roof curbs are narrow to accommodate the small diameter of the springs within the rails, with static deflection in the 1 to 3 in. range to meet the design criteria described in Type 3. Flap-type rubber or metal seals are preferable to a continuous sponge at the perimeter to minimize binding and short-circuiting.</p>

systems; they should not be expected to substitute for conventional pipe vibration isolators.

To accommodate pressure thrust, flexible connectors require an end restraint, which is either (1) added to the connector, (2) incorporated by its design, (3) added to the piping system (anchoring), or (4) built in by the stiffness of the system. Connector extension caused by pressure thrust on isolated equipment should also be considered when flexible connectors are used. Overextension will cause failure. Manufacturers' recommendations on restraint, pressure, and temperature limitations must be strictly observed.

Hose Connectors

Hose connectors accommodate lateral movement perpendicular to length and have very limited or no axial movement capability. Rubber hose connectors can be of molded or hand wrapped construction with wire reinforcing and are available with metal-threaded end fittings or integral rubber flanges. Application of threaded fittings should be limited to 3 in. and smaller pipe diameter. The fittings should be the mechanically expanded type to minimize the possibility of pressure thrust blowout. Flanged types are available in larger pipe sizes. [Table 43](#) lists recommended lengths.

Metal hose is constructed with a corrugated inner core and a braided cover, which helps attain a pressure rating and provides end restraints that eliminate the need for supplemental control assemblies. Short lengths of metal hose or corrugated metal bellows, or pump connectors, are available without braid and have built-in control assemblies. Metal hose is used to control misalignment and vibration rather than noise and is used primarily where temperature

or the pressure of flow media precludes the use of other material. [Table 43](#) provides recommended lengths.

Expansion Joint or Arched Connectors

Expansion joint or arched connectors have one or more convolutions or arches and can accommodate all modes of axial, lateral, and angular movement and misalignment. When made of rubber, they are commonly called expansion joints, spool joints, or spherical connectors; in PTFE, they are known as couplings or expansion joints.

Rubber expansion joints or spool joints are available in two basic types: (1) hand-wrapped with wire and fabric reinforcing, and (2) molded with fabric and wire or with high-strength fabric only

Table 43 Recommended Live Length^a of Flexible Rubber and Metal Hose

Nominal Diameter, in.	Length, ^b in.	Nominal Diameter, in.	Length, ^b in.
0.75	12	4	18
1	12	5	24
1.5	12	6	24
2	12	8	24
2.5	12	10	24
3	18	12	36

^aLive length is end-to-end length for integral flanged rubber hose and is end-to-end less total fitting length for all other types.

^bPer recommendations of Rubber Expansion Division, Fluid Sealing Association.

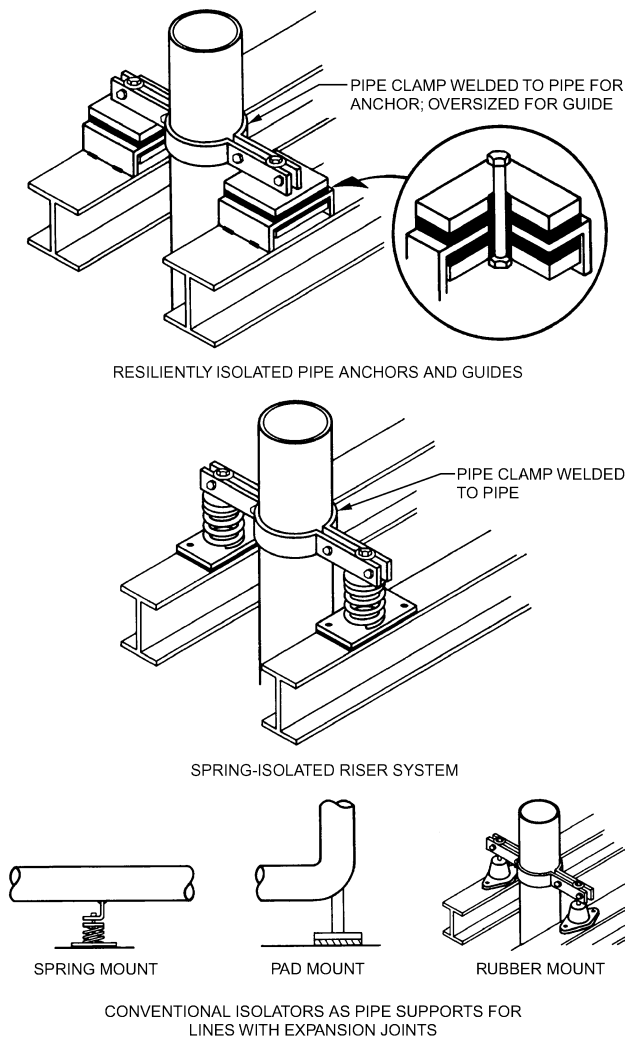

Fig. 41 Resilient Anchors and Guides for Pipes

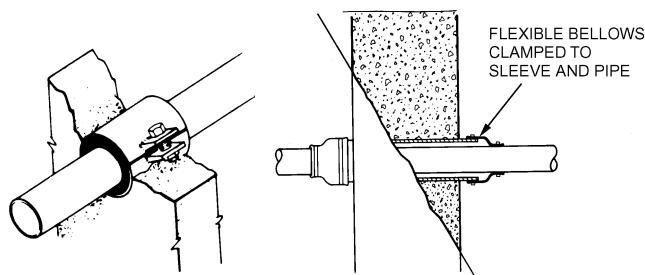

Fig. 42 Acoustical Pipe Penetration Seals

(instead of metal) for reinforcing. The handmade type is available in a variety of materials and lengths for special applications. Rubber spherical connectors are molded with high-strength fabric or tire cord reinforcing instead of metal. Their distinguishing characteristic is a large-radius arch. The shape and construction of some designs permit use without control assemblies in systems operating to 150 psi, and are the most effective for minimizing transmission of vibration. Where thrust restraints are not built in, they must be used as described for rubber hose joints.

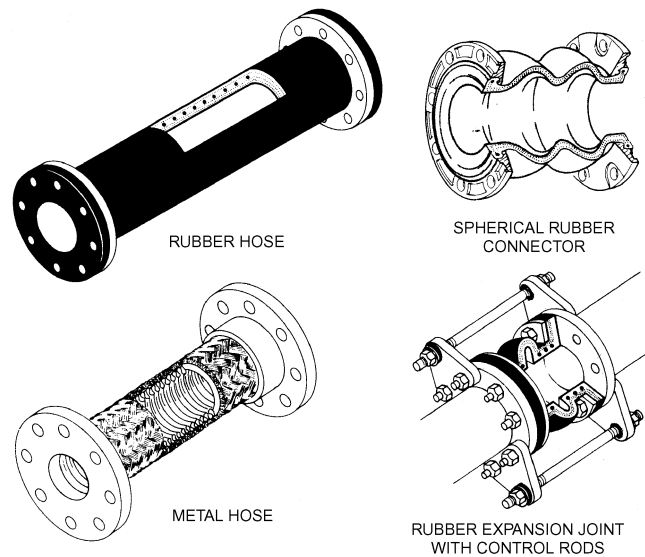

Fig. 43 Flexible Pipe Connectors

PTFE expansion joints and couplings are similar in construction to rubber expansion joints with reinforcing metal rings.

In evaluating these devices, consider temperature, pressure, and service conditions as well as the ability of each device to attenuate vibration and noise. Metal hose connections can accommodate misalignment and attenuate mechanical vibration transmitted through the pipe wall, but do little to attenuate noise. This type of connector has superior resistance to long-term temperature effects. Rubber hose, expansion joints, and spherical connectors attenuate vibration and impeller-generated noise transmitted through the pipe wall. Because rubber expansion joint and spherical connector walls are flexible, they have the ability to grow volumetrically and attenuate noise and vibration at blade-pass frequencies. This is a particularly desirable feature in uninsulated piping systems, such as for condenser water and domestic water, which may run adjacent to noise-sensitive areas. However, high pressure has a detrimental effect on the ability of the connector to attenuate vibration and noise.

Because none of the flexible pipe connectors control flow or velocity noise or completely isolate vibration and noise transmission to the piping system, resilient pipe hangers and supports should be used; these are shown in Note 25 for [Table 42](#) and are described in the Resilient Pipe Hangers and Supports section.

ISOLATING DUCT VIBRATION

Flexible canvas and rubber duct connections should be used at fan intake and discharge. However, they are not completely effective because they become rigid under pressure, allowing the vibrating fan to pull on the duct wall. To maintain a slack position of the flexible duct connections, thrust restraints (see Note 26, [Table 42](#)) should be used on all equipment as indicated in [Table 42](#).

Although vibration transmission from ducts isolated by flexible connectors is not common, flow pulsations within the duct can cause mechanical vibration in the duct walls, which can be transmitted through rigid hangers. Spring or combination spring and rubber hangers are recommended wherever ducts are suspended below or near a noise-sensitive area.

SEISMIC PROTECTION

Seismic restraint requirements are specified by applicable building codes that define design forces to be resisted by the mechanical system, depending on the building location and occupancy, location of

the system within the building, and whether it is used for life safety. Where required, seismic protection of resiliently mounted equipment poses a unique problem, because resiliently mounted systems are much more susceptible to earthquake damage from overturning forces, the impact limits of bare restraints, and resonances inherent in vibration isolators.

A deficiency in seismic restraint design or anchorage may not become apparent until an earthquake occurs, with possible catastrophic consequences. The adequacy of the restraint system and anchorage to resist code design forces must be verified before the event. This verification should be either by equipment tests, calculations, or dynamic analysis, depending on the item, with calculations or dynamic analysis performed under the direction of a professional engineer. These analysis items may be supplied as a package by the vibration isolation vendor.

Restraints for floor-mounted equipment should be designed with adequate clearances so that they are not engaged during normal operation of the equipment. Contact surfaces (snubbers) should be protected with resilient pad material to limit shock during an earthquake and the restraints should be strong enough to resist the forces in any direction. The integrity of these devices can be verified by a comprehensive analysis, but is more frequently verified by laboratory tests.

Calculations or dynamic analyses should have an engineer's seal to verify that input forces are obtained in accordance with code or specification requirements. Additionally, a professional engineer should make the anchorage calculations in accordance with accepted standards. For more information, refer to [Chapter 54, Seismic and Wind Restraint Design](#).

VIBRATION INVESTIGATIONS

Theoretically, a vibration isolation system can be selected to isolate vibration forces of extreme magnitude. However, isolators should not be used to mask a condition that should be corrected before it damages the equipment and its operation. High vibration levels can indicate a faulty equipment operating condition in need of correction, or they can be a symptom of a resonance interaction between a vibrating piece of equipment and the structure on which it is supported.

Vibration investigations should include

- Measurement of the unbalance of reciprocating or rotating equipment components.
- Measurement of vibration levels on vibrating equipment. Refer to [Figure 40](#) for recommended vibration criteria for equipment.
- Measurement of vibration levels in building structures on which vibrating equipment is placed. Refer to [Figure 37](#) and [Table 40](#) for recommended building vibration criteria.
- Examination of equipment vibration generated by system components, such as bearings, drives, etc.
- Measurement of the natural frequency of the supporting structure.
- Examination of equipment installation factors, such as equipment alignment, vibration isolator placement, etc. Refer to [Table 42](#).

TROUBLESHOOTING

Despite all precautions, situations may arise where there is disturbing noise and vibration. Such problems can be identified and corrected by

- Determining which equipment or system is the source of the problem
- Determining whether the problem is one of airborne sound, vibration and structure-borne noise, or a combination of both
- Applying appropriate solutions

Such troubleshooting is time consuming, expensive, and difficult. Once a noise or vibration transmission problem exists, the occupants become more sensitive and require greater reduction of

the sound and vibration levels than would initially have been satisfactory. The need for troubleshooting should be avoided by carefully designing, installing, and testing the system as soon as it is operational and before the building is occupied.

DETERMINING PROBLEM SOURCE

The system or equipment that is the source of the problem can often be determined without instrumentation. Vibration and noise levels are usually well above the sensory level of perception and are readily felt or heard. A simple, accurate method of determining the problem source is to turn individual pieces of equipment on and off until the vibration or noise is eliminated. Because the source of the problem is often more than one piece of equipment or the interaction of two or more systems, it is always good practice to double check by shutting off the system and operating the equipment individually. Reynolds and Bevirt (1994) provides information on the measurement and assessment of sound and vibration in buildings.

DETERMINING PROBLEM TYPE

The next step is to determine if the problem is one of noise or vibration. If vibration is perceptible, vibration transmission is usually the major cause of the problem. The possibility that lightweight wall or ceiling panels are excited by airborne noise should be considered. If vibration is not perceptible, the problem may still be one of vibration transmission causing structure-borne noise, which can be checked via the following procedure:

1. If a sound level meter is available, check C-weighted and overall (unweighted or linear) readings. If the difference is greater than 6 dB, or if the slope of the acoustic spectrum is steeper than 6 dB per octave at low frequencies, vibration is likely a contributing factor.
2. If excessive noise is found close to the equipment and/or main ductwork, airborne noise is probably the main contributor.
3. If the affected area is remote from source equipment, there is no problem in intermediary spaces, and noise does not appear to be coming from the duct system or diffusers, structure-borne noise is probably the cause.

Noise Problems

Noise problems are more complex than vibration problems and usually require the services of an acoustical engineer or consultant.

If the affected area adjoins the room where the source equipment is located, structure-borne noise must be considered as part of the problem, and the vibration isolation systems should be checked. A simple but reasonably effective test is to have one person listen in the affected area while another shouts loudly in the equipment room. If the voice cannot be heard, the problem is likely one of structure-borne noise. If the voice can be heard, check for openings in the wall or floor separating the areas. If no such openings exist, the structure separating the areas does not provide adequate transmission loss. In such situations, refer to the section on Mechanical Equipment Room Sound Isolation for possible solutions.

If ductborne sound (i.e., noise from grilles or diffusers or duct breakout noise) is the problem, measure the sound-pressure levels and compare them with the design RC curves. It is often helpful to remove the terminal device to measure noise levels without the device in place and determine its contribution to the overall noise level. Where the measured curve differs from the design RC curve, the potential noise source(s) can be identified. Once noise sources have been identified, the engineer can analyze each sound source using the procedures presented in this chapter to determine whether sufficient attenuation has been provided.

If the sound source is a fan, pump, or similar rotating equipment, determine whether it is operating at the most efficient part of its operating curve, the point at which most equipment operates best.

Excessive vibration and noise can occur if a fan or pump is trying to move too little or too much air or water; check that vanes, dampers, and valves are in the correct operating position and that the system has been properly balanced.

Vibration Problems

Vibration and structure-borne noise problems can occur from

- Equipment operating with excessive levels of vibration, usually caused by unbalance and/or misalignment
- Inadequate vibration isolators
- Improperly selected or installed vibration isolators that do not provide the required isolator deflection
- Flanking transmission paths such as rigid pipe connections or obstructions under the base of vibration-isolated equipment
- Excessive floor flexibility
- Resonances in equipment, the vibration isolation system, or the building structure

Most field-encountered problems are the result of improperly selected or installed isolators and flanking paths of transmission, which can be simply evaluated and corrected. If the equipment lacks vibration isolators, isolators recommended in [Table 42](#) can be added by using structural brackets without altering connected ducts or piping. Floor flexibility and resonance problems are sometimes encountered and usually require analysis by experts; however, the procedures in the following sections can identify such problems.

Testing Vibration Isolation Systems. Improperly functioning vibration isolation systems are the cause of most field-encountered problems and can be evaluated and corrected by the following procedures:

1. Ensure that the system is free-floating by bouncing the base, which should cause the equipment to move up and down freely and easily. On floor-mounted equipment, check that there are no obstructions between the base and the floor that would short-circuit the isolation system. This is best accomplished by passing a rod under the equipment. A small obstruction might permit the base to rock, giving the impression that it is free-floating when it is not. On suspended equipment, make sure that rods are not touching the hanger box. Rigid connections such as pipes and ducts can prevent equipment from floating freely, prohibit isolators from functioning properly, and provide flanking paths for the transmission of vibration.
2. Determine whether the isolator static deflection is as specified or required, changing it if necessary, as recommended in [Table 42](#). A common problem is inadequate deflection caused by underloaded isolators. Overloaded isolators are not generally a problem as long as the system is free-floating and there is space between the spring coils.

With the most commonly used spring isolators, static deflection can be determined by measuring the operating height and comparing it to the free-height information available from the manufacturer. Once the actual isolator deflection is known, determine its adequacy by comparing it with the recommended deflection in [Table 42](#).

The efficiency of a vibration isolator depends on the ratio of the forcing frequency to the natural frequency of the isolator. If the natural frequency of the isolator is less than 25% of the forcing frequency (usually considered the operating speed of the equipment), the isolator will operate at an efficiency of 95% or greater, and will generally provide sufficient vibration isolation except in solutions where heavy equipment is installed on extremely long-span floors or very flexible floors or roofs. If a transmission problem exists, it may be caused by (1) excessively rough equipment operation, (2) the system not being free-floating or flanking path transmission, or (3) a resonance or floor stiffness problem.

It is easy to determine the natural frequency of spring isolators from the static deflection determined by spring height measurements,

but such measurements are difficult with pad and rubber isolators and are not accurate in determining their natural frequencies. Although such isolators can theoretically provide natural frequencies as low as 4 Hz, they actually provide higher natural frequencies and generally do not provide the desired isolation efficiencies for upper floor equipment locations.

It generally is not possible to determine if design vibration isolation efficiencies have been achieved in field installations by field vibration measurements. However, vibration measurements can be made on vibrating equipment, on equipment supports, on floors supporting vibration-isolated equipment, and on floors in adjacent areas to determine if vibration criteria specified in [Table 40](#) or in [Figures 39](#) and [40](#) have been achieved.

Floor Flexibility Problems. Floor flexibility is not a problem with most equipment and structures; however, such problems can occur with heavy equipment installed on long-span floors or thin slabs and with rooftop equipment installed on light structures of open web joist construction. If floor flexibility is suspected, the isolators should be one-tenth or less as stiff as the floor to eliminate the problem. Floor stiffness can be determined by calculating the additional floor deflection caused by a specific piece of equipment.

For example, if a 10,000 lb piece of equipment causes floor deflection of an additional 0.1 in., floor stiffness is 100,000 lb/in., and an isolator combined stiffness of 10,000 lb/in. or less must be used. Note that the floor stiffness or spring rate, not the total floor deflection, is determined. In this example, the total floor deflection might be 1 in., but if the problem equipment causes 0.1 in. of that deflection, 0.1 in. is the factor that identifies a floor stiffness of 100,000 lb/in.

Resonance Problems. These problems occur when the operating speed of the equipment is the same as or close to the resonance frequency of (1) an equipment component such as a fan shaft or bearing support pedestal, (2) the vibration isolation system, or (3) the resonance frequency of the floor or other building component, such as a wall. Vibration resonances can cause excessive equipment vibration levels, as well as objectionable and possibly destructive vibration transmission in a building. These conditions must always be identified and corrected.

When vibrating mechanical equipment is mounted on vibration isolators on a flexible floor, there are two resonance frequencies that must be considered: that of the floor and that of the isolated equipment. The lower frequency should be controlled by the stiffness (and consequently the static deflection) of the vibration isolators. This frequency should be significantly less than the normal operating speed (or frequency) of the mechanical equipment and is generally not a problem. The higher resonance frequency is associated with and primarily controlled by the stiffness of the supporting structure. This resonance frequency is usually not affected by increasing or decreasing the static deflection of the mechanical equipment vibration isolators. Sometimes, when the floor under mechanical equipment is flexible (as occurs with some long-span floor systems and with roof systems supporting rooftop packaged units), the operating speed of the mechanical equipment can coincide with the floor resonance frequency. When this occurs, changing the static deflection of the vibration isolators may not solve the problem. Alternatives include changing the rotating speed of the equipment, stiffening the structure, or adjusting a variable-frequency drive to avoid the resonant frequency.

Vibration Isolation System Resonance. Always characterized by excessive equipment vibration, vibration isolation system resonance usually results in objectionable transmission to the building structure. However, transmission might not occur if the equipment is on grade or on a stiff floor. Vibration isolation system resonance can be measured with instrumentation or, more simply, by determining the isolator natural frequency as described in the section on Testing Vibration Isolation Systems and comparing this figure to the operating speed of the equipment.

When vibration isolation system resonance exists, the isolator natural frequency must be changed using the following guidelines:

- If the equipment is installed on pad or rubber isolators, isolators with the deflection recommended in [Table 42](#) should be installed.
- If the equipment is installed on spring isolators and there is objectionable vibration or noise transmission to the structure, determine if the isolator is providing the designed deflection. For example, an improperly selected or installed nominal 2 in. deflection isolator could be experiencing only 1/8 in. deflection under its static load, which would be in resonance with equipment operating at 500 rpm. If this is the case, the isolators should be replaced with ones having enough capacity to provide the requisite 2 in. deflection. However, if there is no transmission problem with the isolators, it is not necessary to use greater-deflection isolators than can be conveniently installed.
- If the equipment is installed on spring isolators and there is objectionable noise or vibration transmission, replace the isolators with spring isolators with the deflection recommended in [Table 42](#).

Building Resonances. These problems occur when some part of the structure has a resonance frequency the same as the disturbing frequency or the operating speed of some of the equipment. These problems can exist even if the isolator deflections recommended in [Table 42](#) are used. The resulting objectionable noise or vibration should be evaluated and corrected. Often, the resonance problem stems from the floor on which the equipment is installed, but it can also occur in a remotely located floor, wall, or other building component. If a noise or vibration problem has a remote source that cannot be associated with piping or ducts, building resonance must be suspected.

Building resonance problems can be resolved by the following:

- Reduce the vibration force by balancing the equipment. This is not a practical solution for a true resonance problem; however, it is effective when the disturbing frequency equals the floor's natural frequency, as evidenced by the equal displacement of the floor and the equipment, especially when the equipment is operating with excessive vibration.
- Change the disturbing frequency by changing the equipment operating speed. This is practical only for belt-driven equipment, or equipment driven by variable-frequency drives.

STANDARDS

- AMCA 300. Reverberant Room Method for Sound Testing of Fans.
- ANSI S3.18-1979. Guide for the Evaluation of Human Exposure to Whole Body Vibration.
- ANSI S3.29-1983. Guide to Evaluation of Human Exposure to Vibration in Buildings.
- ANSI S12.2-1995. American National Standard Criteria for Evaluating Room Noise.
- ANSI S12.31-1990. Precision Methods for the Determination of Sound Power Levels of Broad-Band Noise Sources in Reverberation Rooms.
- ANSI S12.32-1990. Precision Methods for the Determination of Sound Power Levels of Discrete-Frequency and Narrow-Band Noise Sources in Reverberation Rooms.
- ANSI S12.34-1988. Engineering Methods for the Determination of Sound Power Levels of Noise Sources for Essentially Free-Field Conditions over a Reflecting Plane.
- ARI 250-1999. Performance and Calibration of Reference Sound Sources.
- ARI 260-2001. Sound Rating of Ducted Air Moving and Conditioning Equipment.
- ARI 270-1995. Sound Rating of Outdoor Unitary Equipment.
- ARI 275-1997. Application of Sound Rating Levels of Outdoor Unitary Equipment.
- ARI 280-1995. Requirements for the Qualification of Reverberant Rooms in the 63 Hz Octave Band.
- ARI 300-2000. Sound Rating and Sound Transmission Loss of Packaged Terminal Equipment.
- ARI 350-2000. Sound Rating of Non-Ducted Indoor Air-Conditioning Equipment.
- ARI 370-1986. Sound Rating of Large Outdoor Refrigerating and Air-Conditioning Equipment.
- ARI 530-1995. Method of Rating Sound and Vibration of Refrigerant Compressors.
- ARI 575-1994. Method of Measuring Machinery Sound Within An Equipment Space.
- ARI 880-1998. Air Terminals.
- ARI 885-1998. Procedure for Estimating Occupied Space Sound Levels in the Application of Air Terminals and Air Outlets.
- ARI 890-2001. Rating of Air Diffusers and Air Diffuser Assemblies.
- ARI *Guideline L-1997*. Assessing the Impact of Air-Conditioning Outdoor Sound Levels in the Residential Community.
- ASHRAE *Standard* 62-1999. Ventilation for Acceptable Indoor Air Quality.
- ASHRAE *Standard* 68-1986R. Laboratory Method of Testing to Determine the Sound Power in a Duct.
- ISO 2631-2-1995. Mechanical Vibration and Shock—Evaluation of Human Exposure to Whole Body Vibration, Part 1: General Requirements.
- ISO 9613-2-1966. Acoustics—Attenuation of Sound During Propagation Outdoors—Part 2: General Method of Calculation.

REFERENCES

- AIA. 2001. *Guideline for design and construction of hospital and health care facilities*. The American Institute of Architects, Washington, D.C.
- ASHRAE. 1991. 1991 *ASHRAE Handbook—HVAC Applications*, Chapter 42.
- ASHRAE. 1995. 1995 *ASHRAE Handbook—HVAC Systems and Applications*, Chapter 43.
- ASHRAE. 2001. *ASHRAE Handbook—Fundamentals*, Chapter 7.
- ASTM. E477. Test method for measuring acoustical and airflow performance of duct liner materials and prefabricated silencers. American Society for Testing and Materials, West Conshohocken, PA.
- Beatty, J. 1987. Discharge duct configurations to control rooftop sound. *Heating/Piping/Air Conditioning* (July).
- Beranek, L.L. 1960. *Noise reduction*. McGraw-Hill, New York.
- Beranek, L.L. 1971. *Noise and vibration control*. McGraw-Hill, New York.
- Beranek, L.L. 1989. Balanced noise criterion (NCB) curves. *Journal of the Acoustic Society of America* (86):650-654.
- Blazier, W.E., Jr. 1981a. Revised noise criteria for design and rating of HVAC systems. *ASHRAE Transactions* 87(1).
- Blazier, W.E., Jr. 1981b. Revised noise criteria for application in the acoustical design and rating of HVAC systems. *Noise Control Engineering Journal* 16(2):64-73.
- Blazier, W.E., Jr. 1993. Control of low frequency noise in HVAC air-handling systems. *ASHRAE Transactions* 99(2).
- Blazier, W.E., Jr. 1995. Sound quality considerations in rating noise from heating, ventilating and air-conditioning (HVAC) systems in buildings. *Noise Control Engineering Journal* 43(3).
- Blazier, W.E., Jr. 1997. RC Mark II; a refined procedure for rating the noise of heating, ventilating and air-conditioning (HVAC) systems in buildings. *Noise Control Engineering Journal* 45(6).
- Broner, N. 1994. Determination of the relationship between low-frequency HVAC noise and comfort in occupied spaces (RP-714). *ASHRAE Transactions* 100(2).
- Bullock, C.E. 1970. Aerodynamic sound generation by duct elements. *ASHRAE Transactions* 76(2):97.
- Cowan, J.P. 1994. *Handbook of environmental acoustics*. Van Nostrand Reinhold, New York.
- Cummings, A. 1983. Acoustic noise transmission through the walls of air-conditioning ducts. *Final Report*. Department of Mechanical and Aerospace Engineering, University of Missouri-Rolla.
- Cummings, A. 1985. Acoustic noise transmission through duct walls. *ASHRAE Transactions* 91(2A).
- Ebbing, C.E., D. Fragnito, and S. Inglis. 1978. Control of low frequency duct-generated noise in building air distribution systems. *ASHRAE Transactions* 84(2).
- Ebbing, C.E. and W.E. Blazier, Jr. 1992. HVAC low frequency noise in buildings. *Proceedings INTER-NOISE* 92(2):767-770.
- Ebbing, C.E. and W.E. Blazier, Jr. 1998. *Application of manufacturer's sound data*. ASHRAE, Atlanta.
- Egan, M.D. 1988. *Architectural acoustics*. McGraw-Hill, New York.
- Environment Canada. 1994. Mineral fibres: Priority substances list assessment report. *Canadian Environmental Protection Act*, Ottawa.
- Harold, R.G. 1986. Round duct can stop rumble noise in air-handling installations. *ASHRAE Transactions* 92(2).

- Harold, R.G. 1991. Rooftop installation sound and vibration considerations. *ASHRAE Transactions* 97(1).
- Ingard, U., A. Oppenheim, and M. Hirschorn. 1968. Noise generation in ducts: ASHRAE RP-37. *ASHRAE Transactions* 74(1).
- IRD. 1988. Vibration technology, Vol. 1. IRD Mechanalysis, Columbus, OH.
- Kuntz, H.L. 1986. The determination of the interrelationship between the physical and acoustical properties of fibrous duct liner materials and lined duct sound attenuation. *Report No. 1068*. Hoover Keith and Bruce, Houston, TX.
- Kuntz, H.L. and R.M. Hoover. 1987. The interrelationships between the physical properties of fibrous duct lining materials and lined duct sound attenuation. *ASHRAE Transactions* 93(2).
- Lilly, J. 1987. Break-out in HVAC duct systems. *Sound & Vibration* (October).
- Machen, J. and J.C. Haines. 1983. Sound insertion loss properties of lina-coustic and competitive duct liners. *Report No. 436-T-1778*. Johns-Manville Research and Development Center, Denver, CO.
- Morey, P.R. and C.M. Williams. 1991. Is porous insulation inside an HVAC system compatible with healthy building? *ASHRAE IAQ Symposium*.
- Persson-Wayne, K., S. Benton, H.G. Leventhall, and R. Rylander. 1997. Effects on performance and work quality due to low frequency ventilation noise. *Journal of Sound and Vibration* 205(4):467-474.
- Reynolds, D.D. and J.M. Bledsoe. 1989a. Sound attenuation of unlined and acoustically lined rectangular ducts. *ASHRAE Transactions* 95(1).
- Reynolds, D.D. and J.M. Bledsoe. 1989b. Sound attenuation of acoustically lined circular ducts and radiused elbows. *ASHRAE Transactions* 95(1).
- Reynolds, D.D. and J.M. Bledsoe. 1991. *Algorithms for HVAC acoustics*. ASHRAE, Atlanta.
- Reynolds, D.D. and W.D. Bevirt. 1989. *Sound and vibration design and analysis*. National Environmental Balancing Bureau, Rockville, MD.
- Reynolds, D.D. and W.D. Bevirt. 1994. *Procedural standards for the measurement and assessment of sound and vibration*. National Environmental Balancing Bureau, Rockville, MD.
- Sandbakken, M., L. Pande, and M.J. Crocker. 1981. Investigation of end reflection of coefficient accuracy problems with AMCA Standard 300-67. *HL 81-16*. Ray W. Herrick Laboratories, Purdue University, West Lafayette, IN.
- Schaffer, M.E. 1991. *A practical guide to noise and vibration control for HVAC systems*. ASHRAE, Atlanta.
- Schultz, T.J. 1985. Relationship between sound power level and sound pressure level in dwellings and offices. *ASHRAE Transactions* 91(1).
- Schultz, T.J. 1972. *Community noise ratings*. Applied Science Publishers, London.
- SMACNA. 1990. *HVAC systems duct design*, 3rd ed. Sheet Metal and Air Conditioning Contractors' National Association, Vienna, VA.
- Thompson, J.K. 1981. The room acoustics equation: Its limitation and potential. *ASHRAE Transactions* 87(2).
- Ungar, E.E., D.H. Sturz, and C.H. Amick. 1990. Vibration control design of high technology facilities. *Sound and Vibration* (July).
- USDHHS. 1994. *Seventh annual report on carcinogens*. U.S. Department of Health and Human Resources, National Technical Information Service, Springfield, VA.
- Ver, I.L. 1978. A review of the attenuation of sound in straight lined and unlined ductwork of rectangular cross section. *ASHRAE Transactions* 84(1).
- Ver, I.L. 1982. A study to determine the noise generation and noise attenuation of lined and unlined duct fittings. *Report No. 5092*. Bolt, Beranek and Newman, Boston.
- Ver, I.L. 1983a. Noise generation and noise attenuation of duct fittings—A review: Part I. *ASHRAE Transactions* 90(2A).
- Ver, I.L. 1983b. A study to determine the noise generation and noise attenuation of lined and unlined duct fittings (RP-265). *ASHRAE Transactions* 90(2A).
- Ver, I.L. 1984a. Noise generation and noise attenuation of duct fittings—A review: Part II. *ASHRAE Transactions* 90(2A).
- Ver, I.L. 1984b. Prediction of sound transmission through duct walls: Break-out and pickup. *ASHRAE Transactions* 90(2A).
- Warnock, A.C.C. 1998. Transmission of sound from air terminal devices through ceiling systems. *ASHRAE Transactions* 104(1A):650-657.
- Wells, R.J. 1958. Acoustical plenum chambers. *Noise Control* (July).
- Woods Fan Division. 1973. *Design for sound*. The English Electric Company.
- WHO. 1986. *International symposium on man-made mineral fibers in the working environment*. World Health Organization, International Agency for Research on Cancer, Copenhagen.

RESOURCES

- Institute of Noise Control Engineers
(INCE) <http://www.inceusa.com>
- National Council of Acoustical
Consultants (NCAC) <http://www.ncac.com>
- Acoustical Society of America (ASA) <http://asa.aip.org>
- Vibration Institute <http://www.vibinst.org>