

CHAPTER 1

LIQUID OVERFEED SYSTEMS

Overfeed System Operation	1.1	Controls	1.5
Refrigerant Distribution	1.2	Evaporator Design	1.5
Oil in System	1.3	Refrigerant Charge	1.6
Circulating Rate	1.4	Start-Up and Operation	1.6
Pump Selection and Installation	1.5	Line Sizing	1.7
		Low-Pressure Receiver Sizing	1.7

OVERFEED systems are those in which excess liquid is forced, either mechanically or by gas pressure, through organized-flow evaporators, separated from the vapor, and returned to the evaporators.

Terminology

Low-pressure receiver. Sometimes referred to as an **accumulator**, this vessel acts as the separator for the mixture of vapor and liquid returning from the evaporators. A constant refrigerant level is usually maintained by conventional control devices.

Pumping unit. One or more mechanical pumps or gas-operated liquid circulators arranged to pump the overfeed liquid to the evaporators. The pumping unit is located below the low-pressure receiver.

Wet returns. Connections between the evaporator outlets and the low-pressure receiver through which the mixture of vapor and overfeed liquid is drawn.

Liquid feeds. Connections between the pumping unit outlet and the evaporator inlets.

Flow control regulators. Devices used to regulate the overfeed flow into the evaporators. They may be needle valves, fixed orifices, calibrated manual regulating valves, or automatic valves designed to provide a fixed liquid rate.

Advantages and Disadvantages

The main advantages of liquid overfeed systems are high system efficiency and reduced operating expenses. These systems have lower energy cost and fewer operating hours because

- The evaporator surface is used efficiently through good refrigerant distribution and completely wetted internal tube surfaces.
- The compressors are protected. Liquid slugs resulting from fluctuating loads or malfunctioning controls are separated from suction gas in the low-pressure receiver.
- Low-suction superheats are achieved where the suction lines between the low-pressure receiver and the compressors are short. This causes a minimum discharge temperature, preventing lubrication breakdown and minimizing condenser fouling.
- With simple controls, evaporators can be hot-gas defrosted with little disturbance to the system.
- Refrigerant feed to evaporators is unaffected by fluctuating ambient and condensing conditions. The flow control regulators do not need to be adjusted after the initial setting because the overfeed rates are not generally critical.
- Flash gas resulting from refrigerant throttling losses is removed at the low-pressure receiver before entering the evaporators. This gas is drawn directly to the compressors and eliminated as a factor in the design of the system low side. It does not contribute to increased pressure drops in the evaporators or overfeed lines.

- Refrigerant level controls, level indicators, refrigerant pumps, and oil drains are generally located in the equipment rooms, which are under operator surveillance or computer monitoring.
- Because of ideal entering suction gas conditions, compressors last longer. There is less maintenance and fewer breakdowns. The oil circulation rate to the evaporators is reduced as a result of the low compressor discharge superheat and separation at the low-pressure receiver (Scotland 1963).
- Overfeed systems have convenient automatic operation.

The following are possible disadvantages:

- In some cases, refrigerant charges are greater than those used in other systems.
- Higher refrigerant flow rates to and from evaporators cause the liquid feed and wet return lines to be larger in diameter than the high-pressure liquid and suction lines for other systems.
- Piping insulation, which is costly, is generally required on all feed and return lines to prevent condensation, frost formation, or heat gain.
- The installed cost may be greater, particularly for small systems or those having fewer than three evaporators.
- The operation of the pumping unit requires added expenses that are offset by the increased efficiency of the overall system.
- The pumping units may require maintenance.
- Pumps sometimes have cavitation problems due to low available net positive suction head.

Generally, the more evaporators used, the more favorable are the initial costs for liquid overfeed compared to a gravity recirculated or flooded system (Scotland 1970). Liquid overfeed systems compare favorably with thermostatic valve feed systems for the same reason. For small systems, the initial cost for liquid overfeed may be higher than for direct expansion.

Ammonia Systems. Easy operation and lower maintenance are attractive features for even small ammonia systems. However, for ammonia systems operating below 0°F evaporating temperature, some manufacturers do not supply direct-expansion evaporators due to unsatisfactory refrigerant distribution and control problems.

OVERFEED SYSTEM OPERATION

Mechanical Pump

[Figure 1](#) shows a simplified pumped overfeed system in which a constant liquid level is maintained in a low-pressure receiver. A mechanical pump circulates liquid through the evaporator(s). The two-phase return mixture is separated in the low-pressure receiver. The vapor is directed to the compressor(s). The makeup refrigerant enters the low-pressure receiver by means of a refrigerant metering device.

[Figure 2](#) shows a horizontal low-pressure receiver with a minimum pump pressure, two service valves in place, and a strainer on the suction side of the pump. Valves from the low-pressure receiver

The preparation of this chapter is assigned to TC 10.1, Custom Engineered Refrigeration Systems.

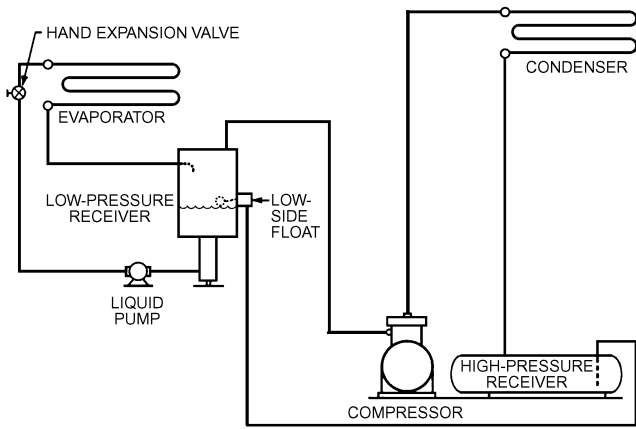

Fig. 1 Liquid Overfeed with Mechanical Pump

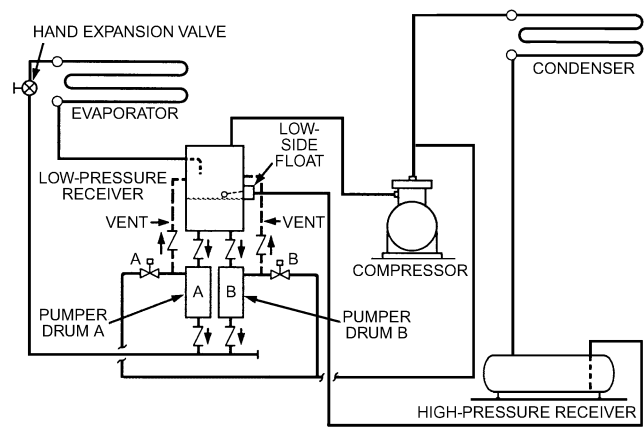

Fig. 3 Double Pumper Drum System

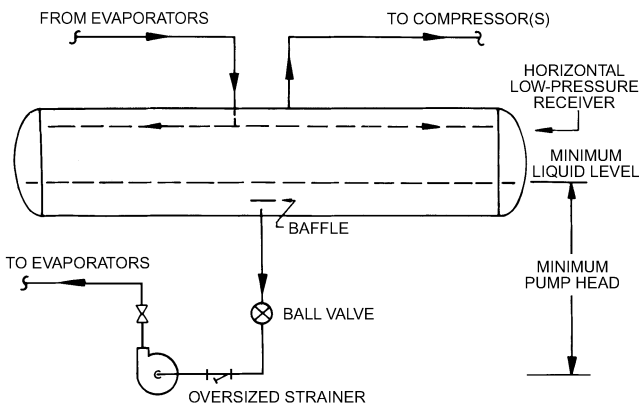

Fig. 2 Pump Circulation, Horizontal Separator

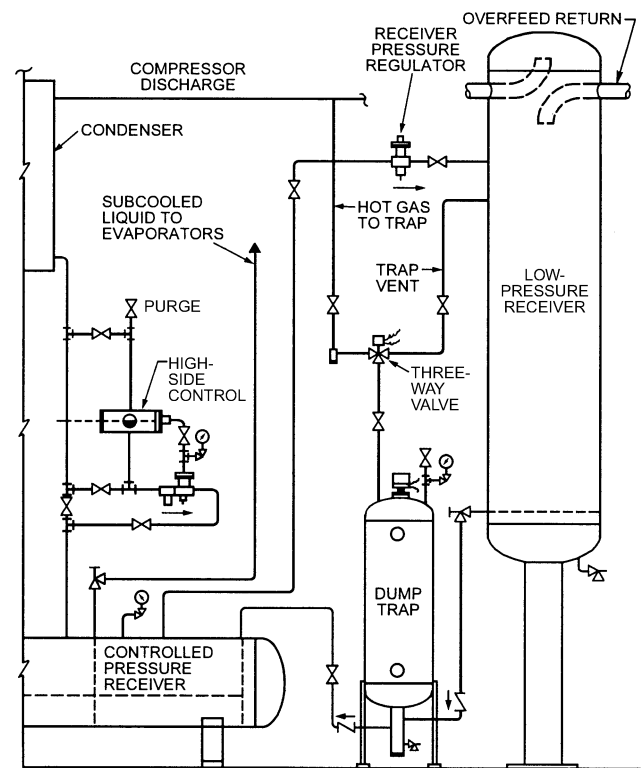

Fig. 4 Constant-Pressure Liquid Overfeed System

to the pump should be selected to have a minimal pressure drop. The strainer protects hermetic pumps when oil is miscible with the refrigerant. It should have a free area twice the transverse cross-sectional area of the line in which it is installed. With ammonia, use of a suction strainer should be evaluated. Open drive pumps do not require strainers. If no strainer is used, a dirt leg should be used to reduce the risk of solids getting into the pump.

Generally, the minimum pump pressure should be at least double the net positive suction pressure to avoid cavitation. The liquid velocity to the pump should not exceed 3 fps. Net positive suction head and flow requirements vary with pump type and design. The pump manufacturer should be consulted for specific requirements. The pump should be evaluated over the full range of operation at low and high flow conditions. Centrifugal pumps have a “flat curve” and have difficulty with systems in which discharge pressure fluctuates.

Gas Pump

Figure 3 shows a basic gas-pumped liquid overfeed system, in which the pumping power is supplied by gas at condenser pressure. In this system, a level control maintains the liquid level in the low-pressure receiver. There are two pumper drums; one is filled by the low-pressure receiver, while the other is drained as hot gas pushes liquid from the pumper drum to the evaporator. Pumper drum B drains when hot gas enters the drum through valve B. To function properly, the pumper drums must be correctly vented so they can fill during the fill cycle.

Another common arrangement is shown in Figure 4. In this system, the high-pressure liquid is flashed into a controlled-pressure receiver that maintains constant liquid pressure at the evaporator

inlets, resulting in continuous liquid feed at constant pressure. The flash gas is drawn into the low-pressure receiver through a receiver pressure regulator. Excess liquid drains into a liquid dump trap from the low-pressure receiver. Check valves and a three-way equalizing valve transfer the liquid into the controlled-pressure receiver during the dump cycle. Refinements of this system are used for multistage systems.

REFRIGERANT DISTRIBUTION

To prevent underfeeding and excessive overfeeding of refrigerants, metering devices regulate the liquid feed to each evaporator and/or evaporator circuit. An automatic regulating device continuously controls refrigerant feed to the design value. Other devices commonly used are hand expansion valves, calibrated regulating valves, orifices, and distributors.

It is time-consuming to adjust hand expansion valves to achieve ideal flow conditions. However, they have been used with some success in many installations prior to the availability of more sophisticated controls. One factor to consider is that standard hand expansion valves are designed to regulate flows caused by the relatively high pressure differences between condensing and evaporating pressure. In overfeed systems, large differences do not exist, so valves with larger orifices may be needed to cope with the combination of the increased quantity of refrigerant and the relatively small pressure differences. Caution must be exercised when using larger orifices because controllability decreases as orifice size increases.

Calibrated, manually operated regulating valves reduce some of the uncertainties involved in using conventional hand expansion valves. To be effective, the valves should be adjusted to the manufacturer's recommendations. Because the refrigerant in the liquid feed lines is above saturation pressure, the lines should not contain flash gas. However, liquid flashing can occur if excessive heat gains by the refrigerant and/or high pressure drops build up in the feed lines.

Orifices should be carefully designed and selected; once installed they cannot be adjusted. They are generally used only for top- and horizontal-feed multicircuit evaporators. Foreign matter and congealed oil globules can cause flow restriction; a minimum orifice of 0.1 in. is recommended. With ammonia, the rate of circulation may have to be increased beyond that needed for the minimum orifice size because of the small liquid volume normally circulated. Pumps and feed and return lines larger than minimum may be needed. This does not apply to halocarbons because of the greater liquid volume circulated as a result of fluid characteristics.

Conventional multiple-outlet distributors with capillary tubes of the type usually paired with thermostatic expansion valves have been used successfully in liquid overfeed systems. Capillary tubes may be installed downstream of a distributor with oversized orifices to achieve the required pressure reduction and efficient distribution.

Existing gravity-flooded evaporators with accumulators can be connected to liquid overfeed systems. Changes may be needed only for the feed to the accumulator, with suction lines from the accumulator connected to the system wet return lines. An acceptable arrangement is shown in Figure 5. Generally, gravity-flooded evaporators have different circulating arrangements from overfeed evaporators. In many cases, the circulating rates developed by thermosiphon action are greater than the circulating rates used in conventional overfeed systems.

Example 1. Find the orifice diameter of an ammonia overfeed system with a refrigeration load per circuit of 1.27 tons and a circulating rate of 7. The evaporating temperature is -30°F , the pressure drop across the

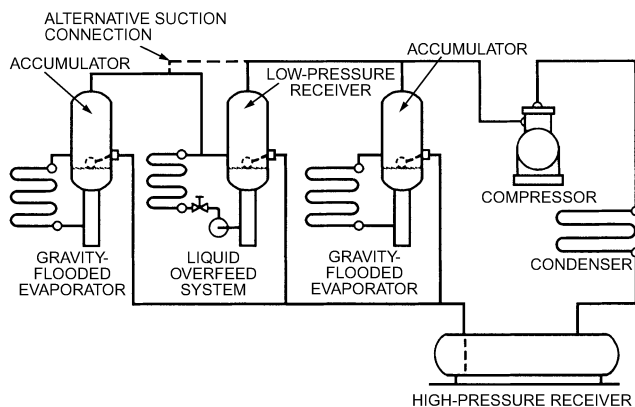

Fig. 5 Liquid Overfeed System Connected on Common System with Gravity-Flooded Evaporators

orifice is 8 psi, and the coefficient of discharge for the orifice is 0.61. The circulation per circuit is 0.528 gpm.

Solution: Orifice diameter may be calculated as follows:

$$d = \left[\frac{Q}{aC_d \sqrt{p/S}} \right]^{0.5} \tag{1}$$

where

- d = orifice diameter, in.
- a = units conversion, 29.81
- Q = discharge through orifice, gpm
- p = pressure drop through orifice, psi
- S = specific gravity of fluid relative to water at -30°F
 $= 5.701/8.336 = 0.6839$
- C_d = coefficient of discharge for orifice

$$d = \left[\frac{0.528}{29.81 \times 0.61 \sqrt{8/0.6839}} \right]^{0.5} = 0.092 \text{ in.}$$

Note: As noted in the text, use a 0.1 in. diameter orifice to avoid clogging.

OIL IN SYSTEM

In spite of reasonably efficient compressor discharge oil separators, oil finds its way into the system low-pressure sides. In ammonia overfeed systems, the bulk of this oil can be drained from the low-pressure receivers with suitable oil drainage facilities. In low-temperature systems, a separate valved and pressure-protected, non-insulated oil drain pot can be placed in a warm space at the accumulator. The oil/ammonia mixture flows into the pot, and the refrigerant evaporates. This arrangement is shown in Figure 6. At pressures lower than atmospheric, high-pressure vapor must be piped into the oil pot to force oil out. Because of the low solubility of oil in liquid ammonia, thick oil globules circulate with the liquid and can restrict flow through strainers, orifices, and regulators. To maintain high efficiency, oil should be removed from the system by regular draining.

Except at low temperatures, halocarbons are miscible with oil. Therefore, positive oil return to the compressor must be ensured. There are many methods, including oil stills using both electric heat and heat exchange from high-pressure liquid or vapor. Some arrangements are discussed in Chapter 2. At low temperatures, oil skimmers must be used because oil migrates to the top of the low-pressure receiver.

Buildup of excessive oil in evaporators must not be allowed because it causes efficiency to decrease rapidly. This is particularly critical in evaporators with high heat transfer rates associated with low volumes, such as flake ice makers, ice cream freezers, and scraped-surface heat exchangers. Because the refrigerant flow rate

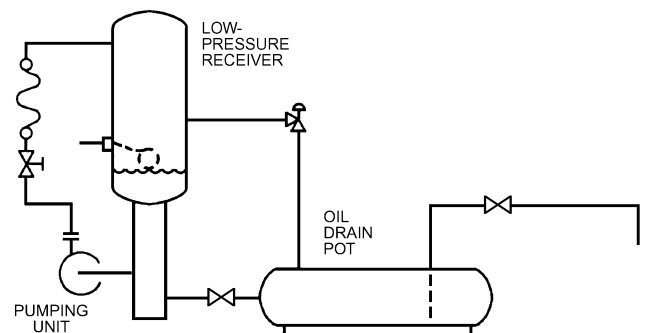

Fig. 6 Oil Drain Pot Connected to Low-Pressure Receiver

through such evaporators is high, excessive oil can accumulate and rapidly reduce efficiency.

CIRCULATING RATE

In a liquid overfeed system, the **circulating number** or **rate** is the mass ratio of liquid pumped to amount of vaporized liquid. The amount of liquid vaporized is based on the latent heat for the refrigerant at the evaporator temperature. The **overfeed rate** is the ratio of liquid to vapor returning to the low-pressure receiver. When vapor leaves an evaporator at saturated vapor conditions with no excess liquid, the circulating rate is 1 and the overfeed rate is 0. With a circulating rate of 4, the overfeed rate at full load is 3; at no load, it is 4. Most systems are designed for steady flow conditions. With few exceptions, the load conditions may vary, causing fluctuating temperatures outside and within the evaporator. Evaporator capacities vary considerably; with constant refrigerant flow to the evaporator, the overfeed rate fluctuates.

For each evaporator, there is an ideal circulating rate for every loading condition that will result in the minimum temperature difference and the best evaporator efficiency (Lorentzen 1968; Lorentzen and Gronnerud 1967). With few exceptions, it is impossible to predict ideal circulating rates or to design a plant for automatic adjustment of the rates to suit fluctuating loads. The optimum rate can vary with heat load, pipe diameter, circuit length, and number of parallel circuits to achieve the best performance. High circulating rates can cause excessively high pressure drops through evaporators and wet return lines. The sizing of these return lines, discussed in the section on Line Sizing, can have a bearing on the ideal rates. Many evaporator manufacturers specify recommended circulating rates for their equipment. The rates shown in [Table 1](#) agree with these recommendations.

Because of distribution considerations, higher circulating rates are common with top feed evaporators. In multicircuit systems, the refrigerant distribution must be adjusted to provide the best possible results. Incorrect distribution can cause excessive overfeed in some circuits, while others may be starved. Manual or automatic regulating valves can be used to control flow for the optimum or design value.

Halocarbon densities are about twice that of ammonia. If halocarbons R-22, R-134a, and R-502 are circulated at the same rate as ammonia, the halocarbons require 6 to 8.3 times more energy for pumping to the same height than the less dense ammonia. Because this pumping energy must be added to the system load, halocarbon circulating rates are usually lower than those for ammonia. Ammonia has a relatively high latent heat of vaporization, so for equal heat removal, much less ammonia mass must be circulated compared to halocarbons.

Although halocarbons circulate at lower rates than ammonia, the wetting process in the evaporators is still efficient because of the liquid and vapor volume ratios. For example, at -40°F evaporating temperature, with constant flow conditions in the wet return connections, similar ratios of liquid and vapor are experienced with a circulating rate of 4 for ammonia and 2.5 for R-22, R-502, and R-134a. With halocarbons, some additional wetting is also experienced because of the solubility of the oil in these refrigerants.

When bottom feed is used for multicircuit coils, a minimum feed rate per circuit is not necessary because orifices or other distribution devices are not required. The circulating rate for top feed

and horizontal feed coils may be determined by the minimum rates from the orifices or other distributors in use.

[Figure 7](#) provides a method for determining the liquid refrigerant flow (Niederer 1964). The charts indicate the amount of refrigerant vaporized in a 1 ton system with circulated operation having no flash gas in the liquid feed line. The value obtained from the chart may be multiplied by the desired circulating rate and by the total refrigeration to determine total flow.

The pressure drop through the flow control regulators is usually 10 to 50% of the available feed pressure. The pressure at the outlet of the flow regulators must be higher than the vapor pressure at the low-pressure receiver by an amount equal to the total pressure drop of the two-phase mixture through the evaporator, any evaporator pressure regulator, and wet return lines. This pressure loss could be 5 psi in a typical system. When using recommended liquid feed sizing practices, assuming a single-story building, the frictional pressure drop from the pump discharge to the evaporators is about 10 psi. Therefore, a pump for 20 to 25 psi should be satisfactory in this case, depending on the lengths and sizes of feed lines, the quantity and types of fittings, and the vertical lift involved.

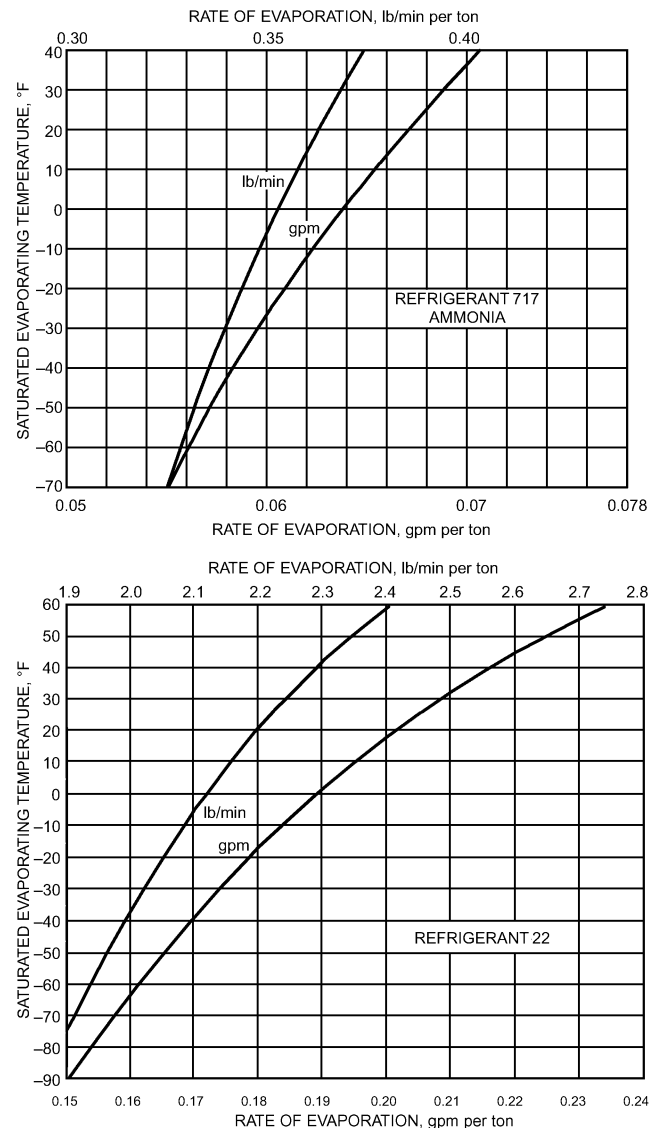

Fig. 7 Charts for Determining Rate of Refrigerant Feed (No Flash Gas)

Table 1 Recommended Minimum Circulating Rate

Refrigerant	Circulating Rate*
Ammonia (R-717)	
Downfeed (large-diameter tubes)	6 to 7
Upfeed (small-diameter tubes)	2 to 4
R-22—upfeed	3
R-134a	2

*Circulating rate of 1 equals evaporating rate.

PUMP SELECTION AND INSTALLATION

Types of Pumps

Mechanical pumps, gas pressure pumping systems, and injector systems are available for liquid overfeed systems.

Types of mechanical pump drives include open, semihermetic, magnetic clutch, and hermetic. Rotor arrangements include positive rotary, centrifugal, and turbine vane. Positive rotary and gear pumps are generally operated at slow speeds up to 900 rpm. Whatever type of pump is used, care should be taken to prevent flashing at the pump suction and/or within the pump itself.

Centrifugal pumps are typically used for larger volumes, while semihermetic pumps are best suited for halocarbons at or below atmospheric refrigerant saturated pressure. Regenerative turbines are used with relatively high pressure and large swings in discharge pressure.

Open pumps are fitted with a wide variety of packing or seals. For continuous duty, a mechanical seal with an oil reservoir or a liquid refrigerant supply to cool, wash, and lubricate the seals is commonly used. Experience with the particular application or the recommendations of an experienced pump supplier are the best guide for selecting the packing or seal. A magnetic coupling between the motor and the pump can be used instead of shaft coupling to eliminate shaft seals. A small immersion electric heater within the oil reservoir can be used with low-temperature systems to ensure that the oil remains fluid. Motors should have a service factor that compensates for drag on the pump if the oil is cold or stiff.

Considerations should include ambient temperatures, heat leakage, fluctuating system pressures from compressor cycling, internal bypass of liquid to pump suction, friction heat, motor heat conduction, dynamic conditions, cycling of automatic evaporator liquid and suction stop valves, action of regulators, gas entrance with liquid, and loss of subcooling by pressure drop. Another factor to consider is the time lag caused by the heat capacity of pump suction, cavitation, and net positive suction head factors (Lorentzen 1963).

The motor and stator of hermetic pumps are separated from the refrigerant by a thin nonmagnetic membrane. The metal membrane should be strong enough to withstand system design pressures. Normally, the motors are cooled and the bearings lubricated by liquid refrigerant bypassed from the pump discharge. It is good practice to use two pumps, one operating and one standby.

Installing and Connecting Mechanical Pumps

Because of the sensitive suction conditions of mechanical pumps operating on overfeed systems, the manufacturer's application and installation specifications must be followed closely. Suction connections should be as short as possible, without restrictions, valves, or elbows. Angle or full-flow ball valves should be used. Using valves with horizontal valve spindles eliminates possible traps. Gas binding is more likely with high evaporating pressures.

Installing discharge check valves prevents backflow. Relief valves should be used, particularly for positive displacement pumps. Strainers are not usually installed in ammonia pump suction lines because they plug with oil. Strainers, although a poor substitute for a clean installation, protect halocarbon pumps from damage by dirt or pipe scale.

Pump suction connections to liquid legs (vertical drop legs from low-pressure receivers) should be made above the bottom of the legs to allow collection space for solids and sludge. Vortex eliminators should be considered, particularly when submersion of the suction inlet is insufficient to prevent the intake of gas bubbles. Lorentzen (1963, 1965) gives more complete information.

Sizing the pump suction line is important. The general velocity should be about 3 fps. Small lines cause restrictions; oversized lines can cause bubble formation during evaporator temperature decrease because of the heat capacity of the liquid and piping. Oversized lines also impose increased heat gain from the ambient spaces. Oil

heaters for the seal lubrication system keep the oil fluid, particularly during subzero operation. Thermally insulating all cold surfaces of pumps, lines, and receivers increases efficiency.

CONTROLS

The liquid level in the low-pressure receiver can be controlled by conventional devices such as low-pressure float valves, combinations of float switch and solenoid valve with manual regulator, thermostatic level controls, electronic level sensors, or other proven automatic devices. High-level float switches are useful in stopping compressors and/or operating alarms; they are mandatory in some areas. Solenoid valves should be installed on liquid lines (minimum sized) feeding low-pressure receivers so that positive shutoff is automatically achieved with system shutdown. This prevents excessive refrigerant from collecting in low-pressure receivers, which can cause carryover at start-up.

To prevent pumps from operating without liquid, low-level float switches can be fitted on liquid legs. An alternative device, a differential pressure switch connected across pump discharge and suction connections, causes the pump to stop without interrupting liquid flow. Cavitation can also cause this control to operate. When hand expansion valves are used to control the circulation rate to evaporators, the orifice should be sized for operation between system high and low pressures. Occasionally, with reduced inlet pressure conditions, these valves can starve the circuit. Calibrated, manually adjusted regulators are available to meter the flow according to the design conditions. An automatic flow-regulating valve specifically for overfeed systems is available.

Liquid and suction solenoid valves must be selected for refrigerant flow rates by mass or volume, not by refrigeration ratings from capacity tables. Evaporator pressure regulators should be sized according to the manufacturer's ratings for overfeed systems. The manufacturer should be notified that valves being ordered are for overfeed application because slight modifications may be required. When evaporator pressure regulators are used on overfeed systems for controlling air defrosting of cooling units (particularly when fed with very low temperature liquid), the refrigerant heat gain may be achieved by sensible effect, not by latent effect. In such cases, other defrosting methods should be investigated. The possibility of connecting the units directly to high-pressure liquid should be considered, especially if the loads are minor.

When a check valve and a solenoid valve are paired on an overfeed system liquid line, the check valve should be downstream from the solenoid valve. When the solenoid valve is closed, dangerous hydraulic pressure can build up from the expansion of the trapped liquid as it is heated. When evaporator pressure regulators are used, the pressure of the entering liquid should be high enough to cause flow into the evaporator.

Multicircuit systems must have a bypass relief valve in the pump discharge. The relief valve's pressure should be set considering the back pressure on the valve from the low-pressure receiver. For example, if the low-pressure receiver is set at 50 psi and the maximum discharge pressure from the pump is 150 psi, the relief valve should be set at 100 psi. When some of the circuits are closed, the excess liquid is bypassed into the low-pressure receiver rather than forced through the evaporators still in operation. This prevents higher evaporating temperatures from pressurizing evaporators and reducing capacities of operating units. Where low-temperature liquid feeds can be isolated manually or automatically, relief valves can be installed to prevent damage from excessive hydraulic pressure.

EVAPORATOR DESIGN

Considerations

There is an ideal refrigerant feed and flow system for each evaporator design and arrangement. An evaporator designed for

gravity-flooded operation cannot always be converted to an overfeed arrangement, and vice versa, nor can systems always be designed to circulate the optimum flow rate. When top feed is used to ensure good distribution, a minimum quantity per circuit must be circulated, generally about 0.5 gpm. Distribution in bottom-feed evaporators is less critical than in top or horizontal feed because each circuit fills with liquid to equal the pressure loss in other parallel circuits.

Circuit length in evaporators is determined by allowable pressure drop, load per circuit, tubing diameter, overfeed rate, type of refrigerant, and heat transfer coefficients. The most efficient circuiting is determined in most cases through laboratory tests conducted by the evaporator manufacturers. Their recommendations should be followed when designing systems.

Top Feed Versus Bottom Feed

System design must determine whether evaporators are to be top fed or bottom fed, although both feed types can be installed in a single system. Each feed type has advantages; no best arrangement is common to all systems.

Advantages of **top feed** include

- Smaller refrigerant charge
- Possibly smaller low-pressure receiver
- Possible absence of static pressure penalty
- Better oil return
- Quicker, simpler defrost arrangements

For halocarbon systems with greater fluid densities, the refrigerant charge, oil return, and static pressure are very important.

Bottom feed is advantageous in that

- Distribution considerations are less critical
- Relative locations of evaporators and low-pressure receivers are less important
- System design and layout are simpler

The top-feed system is limited by the relative location of components. Because this system sometimes requires more refrigerant circulation than bottom-feed systems, it has greater pumping load, possibly larger feed and return lines, and increased line pressure drop penalties. In bottom-feed evaporators, multiple headers with individual inlets and outlets can be installed to reduce static pressure penalties. For high lift of return overfeed lines from the evaporators, dual suction risers eliminate static pressure penalties (Miller 1974, 1979).

Distribution must be considered when a vertical refrigerant feed is used because of the static pressure variations in the feed and return header circuits. For example, for equal circuit loadings in a horizontal-airflow unit cooler, use of gradually smaller orifices for the bottom-feed circuits than for the upper circuits can compensate for pressure differences.

When the top-feed free-draining arrangement is used for air-cooling units, liquid solenoid control valves can be used during the defrost cycle. This applies in particular to air, water, or electric defrost units. Any liquid remaining in the coils rapidly evaporates or drains to the low-pressure receiver. Defrost is faster than in bottom-feed evaporators.

REFRIGERANT CHARGE

Overfeed systems need more refrigerant than dry expansion systems. Top-feed arrangements have smaller charges than bottom-feed systems. The amount of charge depends on the evaporator volume, the circulating rate, the sizes of flow and return lines, the operating temperature differences, and the heat transfer coefficients. Generally, top-feed evaporators operate with the refrigerant charge occupying about 25 to 40% of the evaporator volume. The refrigerant charge for the bottom-feed arrangement occupies about

60 to 75% of the evaporator volume with corresponding variations in the wet returns. Under certain no-load conditions in up-feed evaporators, the charge may occupy 100% of the evaporator volume. In this case, the liquid surge volume from full-load to no-load condition must be considered in sizing the low-pressure receiver (Miller 1971, 1974).

Evaporators with high heat transfer rates, such as flake ice makers and scraped-surface heat exchangers, have small charges because of small evaporator volumes. The amount of refrigerant in the low side has a major effect on the size of the low-pressure receiver, especially in horizontal vessels. The cross-sectional area for vapor flow in horizontal vessels is reduced with increasing liquid level. It is important to ascertain the evaporator refrigerant charge with fluctuating loads for correct vessel design, particularly for a low-pressure receiver that does not have a constant level control but is fed through a high-pressure control.

START-UP AND OPERATION

All control devices should be checked before start-up. If mechanical pumps are used, the direction of operation must be correct. System evacuation and charging procedures are similar to those for other systems. The system must be operating under normal conditions to determine the total required refrigerant charge. Liquid height is established by liquid level indicators in the low-pressure receivers.

Calibrated, manually operated regulators should be set for the design conditions and adjusted for better performance when necessary. When hand expansion valves are used, the system should be started by opening the valves about one-quarter to one-half turn. When balancing is necessary, the regulators should be cut back on those circuits not starved of liquid to force the liquid through the underfed circuits. The outlet temperature of the return line from each evaporator should be the same as the saturation temperature of the main return line, allowing for pressure drops. Starved circuits are indicated by temperatures higher than those for adequately fed circuits. Excessive feed to a circuit increases the evaporator temperature because of excessive pressure drop.

The relief bypass from the liquid line to the low-pressure receiver should be adjusted and checked to ensure that it is functioning. During operation, the pump manufacturer's recommendations regarding lubrication and maintenance should be followed. Regular oil draining procedures should be established for ammonia systems; a comparison should be made between the quantities of oil added to and drained from each system. This comparison determines whether oil is accumulating in systems. Oil should not be drained in halocarbon systems. Due to the miscibility of oil with halocarbons at high temperatures, it may be necessary to add oil to the system until an operating balance is achieved (Stoecker 1960; Soling 1971).

Operating Costs and Efficiency

Operating costs for overfeed systems are generally lower than for other systems. Operating costs may not be lower in all cases due to the variety of inefficiencies that exist from system to system and from plant to plant. However, in cases where existing dry expansion plants were converted to liquid overfeed, the operating hours, power, and maintenance costs were reduced. The efficiency of the early gas pump systems has been improved by using high-side pressure to circulate the overfeed liquid. This type of system is indicated in the controlled pressure system shown in [Figure 4](#). Refinements of the double pumper drum arrangement (shown in [Figure 3](#)) have also been developed.

Gas-pumped systems, which use refrigerant gas to pump liquid to the evaporators or to the controlled-pressure receiver, require additional compressor volume, from which no useful refrigeration is obtained. These systems consume 4 to 10% or more of the compressor power to maintain the refrigerant flow.

If the condensing pressure is reduced as much as 10 psi, the compressor power per unit of refrigeration drops by about 7%. Where outdoor dry- and wet-bulb conditions allow, a mechanical pump can be used to pump the gas with no effect on evaporator performance. Gas-operated systems must, however, maintain the condensing pressure within a much smaller range to pump the liquid and maintain the required overfeed rate.

LINE SIZING

The liquid feed line to the evaporator and the wet return line to the low-pressure receiver cannot be sized by the method described in Chapter 35 of the *ASHRAE Handbook—Fundamentals*. Figure 7 can be used to size liquid feed lines. The circulating rate from Table 1 is multiplied by the evaporating rate. For example, an evaporator with a circulating rate of 4 that forms vapor at a rate of 5 lb/min needs a feed line sized for $4 \times 5 = 20$ lb/min.

Alternative methods that may be used to design wet returns include the following:

- Use one pipe size larger than calculated for vapor flow alone.
- Use a velocity selected for dry expansion reduced by the factor $\sqrt{1/\text{Circulating Rate}}$. This method suggests that the wet-return velocity for a circulating rate of 4 is $\sqrt{1/4} = 0.5$, or half that of the acceptable dry-vapor velocity.
- Use the design method described by Chaddock et al. (1972). The report includes tables of flow capacities at 2°F drop per 100 ft of horizontal lines for R-717 (ammonia), R-12, R-22, and R-502.

When sizing refrigerant lines, the following design precautions should be taken:

- Carefully size overfeed return lines with vertical risers because more liquid is held in risers than in horizontal pipe. This holdup increases with reduced vapor flow and increases pressure loss because of gravity and two-phase pressure drop.
- Use double risers with halocarbons to maintain velocity at partial loads and to reduce liquid static pressure loss (Miller 1979).
- Add the equivalent of a 100% liquid static height penalty to the pressure drop allowance to compensate for liquid holdup in ammonia systems that have unavoidable vertical risers.
- As alternatives in severe cases, provide traps and a means of pumping liquids, or use dual-pipe risers.
- Install low pressure drop valves so the stems are horizontal or nearly so (Chisolm 1971).

LOW-PRESSURE RECEIVER SIZING

Low-pressure receivers are also called liquid separators, suction traps, accumulators, liquid-vapor separators, flash coolers, gas and liquid coolers, surge drums, knock-out drums, slop tanks, or low-side pressure vessels, depending on their function and the preference of the user.

The sizing of low-pressure receivers is determined by the required liquid holdup volume and the allowable gas velocity. The volume must accommodate the fluctuations of liquid in the evaporators and overfeed return lines as a result of load changes and defrost periods. It must also handle the swelling and foaming of the liquid charge in the receiver, which is caused by boiling during temperature increase or pressure reduction. At the same time, a liquid seal must be maintained on the supply line for continuous circulation devices. A separating space must be provided for gas velocity low enough to cause a minimum entrainment of liquid drops into the suction outlet. Space limitations and design requirements result in a wide variety of configurations (Miller 1971; Stoecker 1960; Lorentzen 1966; Niemeyer 1961; Scheiman 1963, 1964; Sonders and Brown 1934; Younger 1955).

In selecting a gas-and-liquid separator, adequate volume for the liquid supply and a vapor space above the minimum liquid height

for liquid surge must be provided. This requires an analysis of operating load variations. This, in turn, determines the **maximum operating liquid level**. Figures 8 and 9 identify these levels and the important parameters of vertical and horizontal gravity separators.

Vertical separators maintain the same separating area with level variations, while separating areas in horizontal separators change with level variations. **Horizontal separators** should have inlets and outlets separated horizontally by at least the vertical separating distance. A useful arrangement in horizontal separators distributes the inlet flow into two or more connections to reduce turbulence and horizontal velocity without reducing the residence time of the gas flow within the shell (Miller 1971).

In horizontal separators, as the horizontal separating distance is increased beyond the vertical separating distance, the residence time of the vapor passing through is increased so that higher velocities than allowed in vertical separators can be tolerated. As the separating distance is reduced, the amount of liquid entrainment from gravity separators increases. Table 2 shows the gravity separation velocities. For surging loads or pulsating flow associated with large step changes in capacity, the maximum steady-flow velocity should be reduced to a value achieved by a suitable multiplier such as 0.75.

The gas-and-liquid separator may be designed with baffles or eliminators to separate liquid from the suction gas returning from the top of the shell to the compressor. More often, sufficient separation space is allowed above the liquid level for this purpose. Such a design is usually of the vertical type, with a separation height above

Table 2 Maximum Effective Separation Velocities for R-717, R-22, R-12, and R-502, with Steady Flow Conditions

Temp., °F	Vertical Separation Distance, in.	Maximum Steady Flow Velocity, fpm			
		R-717	R-22	R-12	R-502
+50	10	29	13	16	11
	24	125	62	70	50
	36	139	77	85	62
+20	10	42	19	22	15
	24	172	86	96	69
	36	195	102	115	83
-10	10	61	27	32	22
	24	253	120	135	97
	36	281	141	159	116
-40	10	95	41	47	33
	24	392	173	198	140
	36	428	205	230	165
-70	10	158	65	72	50
	24	649	267	303	212
	36	697	310	351	247

Source: Adapted from Miller (1971).

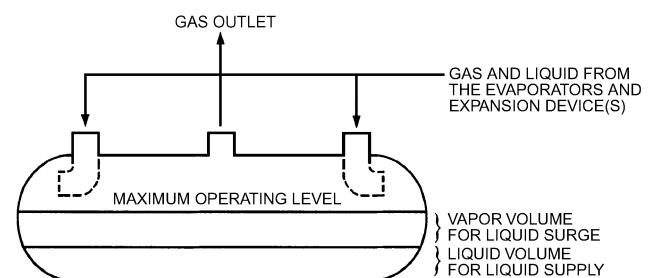
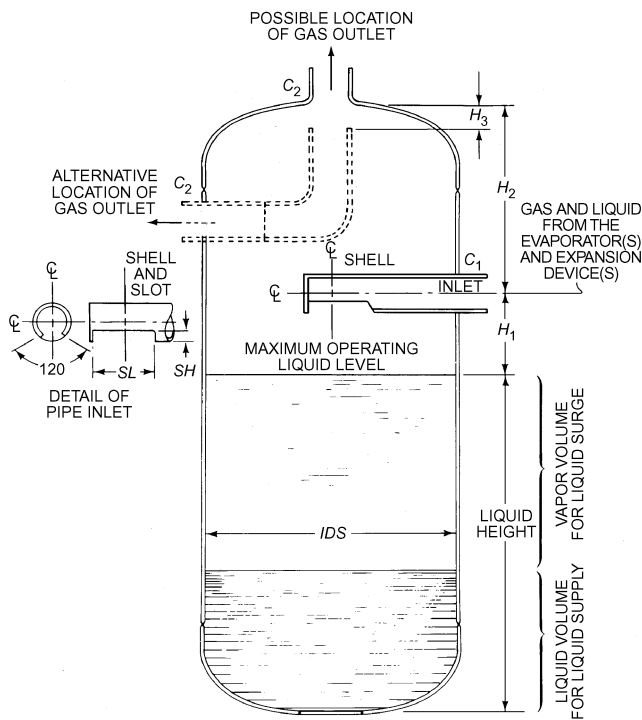

Fig. 8 Basic Horizontal Gas-and-Liquid Separator



- C_1 = inlet pipe diameter, OD, in.
- C_2 = outlet pipe diameter, OD, in.
- SH = slot height = $C_1/4$, in.
- SL = slot length = $3C_1$, in.
- H_1 = height of C_1 above maximum liquid level, in.; for pseudo $D = 24$ in.
- $H_1 = \sqrt{7.33Q/V}$, in. (at $D = 24$ in.)
- Q = maximum gas flow in the shell at maximum sustained operating conditions, cfm
- V = separation velocity, fpm
- H_2 = location of C_1 from inside top of shell, in.
- $H_2 = D + 0.5 \times \text{depth of curved portion of head or } 2$ in.
- D = vertical separation distance, in. actual
- H_3 = location of gas exit point for alternate location of C_2 measured from inside top of shell, in.
- $H_3 = 0.5 \times \text{depth of curved portion of shell or } 2$ in., whichever is greater
- IDS = internal diameter of shell = $\sqrt{183Q/V}$, in.

Fig. 9 Basic Vertical Gravity Gas and Liquid Separator

the liquid level of from 24 to 36 in. The shell diameter is sized to keep the suction gas velocity at a value low enough to allow the liquid droplets to separate and not be entrained with the returning suction gas off the top of the shell.

Although separators are made with length-to-diameter (L/D) ratios of 1/1 increasing to 10/1, the least expensive separators usually have L/D ratios between 3/1 and 5/1. Vertical separators are normally used for systems with reciprocating compressors. Horizontal separators may be preferable where vertical height is critical and/or where large volume space for liquid is required. The procedures for designing vertical and horizontal separators are different.

A vertical gas-and-liquid separator is shown in Figure 9. The end of the inlet pipe C_1 is capped so that flow dispersion is directed downward toward the liquid level. The suggested opening is four times the transverse internal area of the pipe. The height H_1 with a 120° dispersion of the flow reaches to approximately 70% of the internal diameter of the shell.

An alternative inlet pipe with a downturned elbow or mitered bend can be used. However, the jet effect of entering fluid must be considered to avoid undue splashing. The outlet of the pipe must be a minimum distance of $IDS/5$ above the maximum liquid level in the shell. H_2 is measured from the outlet to the inside top of the shell. It equals $D + 0.5$ times the depth of the curved portion of the head.

For the alternative location of C_2 , determine IDS from the following equation:

$$IDS = \sqrt{\frac{183Q}{V} + C_2^2} \tag{2}$$

The maximum liquid height in the separator is a function of the type of system in which the separator is being used. In some systems this can be estimated, but in others, previous experience is the only guide for selecting the proper liquid height. The accumulated liquid must be returned to the system by a suitable means at a rate comparable to the rate at which it is being collected.

With a horizontal separator, the vertical separation distance used is an average value. The top part of the horizontal shell restricts the gas flow so that the maximum vertical separation distance cannot be used. If H_t represents the maximum vertical distance from the liquid level to the inside top of the shell, the average separation distance as a fraction of IDS is as follows:

H_t/IDS	D/IDS	H_t/IDS	D/IDS
0.1	0.068	0.6	0.492
0.2	0.140	0.7	0.592
0.3	0.215	0.8	0.693
0.4	0.298	0.9	0.793
0.5	0.392	1.0	0.893

The suction connection(s) for refrigerant gas leaving the horizontal shell must be located at or above the location established by the average distance for separation. The maximum cross-flow velocity of gas establishes the residence time for the gas and any entrained liquid droplets in the shell. The most effective removal of entrainment occurs when the residence time is at a maximum practical value. Regardless of the number of gas outlet connections for uniform distribution of gas flow, the cross-sectional area of the gas space is

$$A_x = \frac{288DQ}{VL} \tag{3}$$

where

- A_x = minimum transverse net cross-sectional area or gas space, in²
- D = average vertical separation distance, in.
- Q = total quantity of gas leaving vessel, cfm
- L = inside length of shell, in.
- V = separation velocity for separation distance used, fpm

For nonuniform distribution of gas flow in the horizontal shell, determine the minimum horizontal distance for gas flow from point of entry to point of exit as follows:

$$RTL = \frac{144QD}{VA_x} \tag{4}$$

where

- RTL = residence time length, in.
- Q = maximum flow for that portion of the shell, cfm

All connections must be sized for the flow rates and pressure drops permissible and must be positioned to minimize liquid splashing. Internal baffles or mist eliminators can reduce the diameter of vessels; however, test correlations are necessary for a given configuration and placement of these devices.

An alternative formula for determining separation velocities that can be applied to separators is

$$v = k \sqrt{\frac{\rho_l - \rho_v}{\rho_v}} \quad (5)$$

where

- v = velocity of vapor, fps
- ρ_l = density of liquid, lb/ft³
- ρ_v = density of vapor, lb/ft³
- k = factor based on experience without regard to vertical separation distance and surface tension for gravity separators

In gravity liquid/vapor separators that must separate heavy entrainment from vapors, use a k of 0.1. This gives velocities equivalent to those used for 12 to 14 in. vertical separation distance for R-717 and 14 to 16 in. vertical separation distance for halocarbons. In knockout drums that separate light entrainment, use a k of 0.2. This gives velocities equivalent to those used for 36 in. vertical separation distance for R-717 and for halocarbons.

REFERENCES

- Chaddock, J.B., D.P. Werner, and C.G. Papachristou. 1972. Pressure drop in the suction lines of refrigerant circulation systems. *ASHRAE Transactions* 78(2):114-123.
- Chisholm, D. 1971. Prediction of pressure drop at pipe fittings during two-phase flow. *Proceedings I.I.R.*, Washington, D.C.
- Lorentzen, G. 1963. Conditions of cavitation in liquid pumps for refrigerant circulation. *Progress Refrigeration Science Technology* 1:497.
- Lorentzen, G. 1965. How to design piping for liquid recirculation. *Heating, Piping & Air Conditioning* (June):139.
- Lorentzen, G. 1966. On the dimensioning of liquid separators for refrigeration systems. *Kältetechnik* 18:89.
- Lorentzen, G. 1968. Evaporator design and liquid feed regulation. *Journal of Refrigeration* (November-December):160.
- Lorentzen, G. and R. Gronnerud. 1967. On the design of recirculation type evaporators. *Kulde* 21(4):55.
- Miller, D.K. 1971. Recent methods for sizing liquid overfeed piping and suction accumulator-receivers. *Proceedings I.I.R.*, Washington, D.C.
- Miller D.K. 1974. Refrigeration problems of a VCM carrying tanker. *ASHRAE Journal* 11.
- Miller, D.K. 1979. Sizing dual suction risers in liquid overfeed refrigeration systems. *Chemical Engineering* 9.

- Niederer, D.H. 1964. Liquid recirculation systems—What rate of feed is recommended. *The Air Conditioning & Refrigeration Business* (December).
- Niemeyer, E.R. 1961. Check these points when designing knockout drums. *Hydrocarbon Processing and Petroleum Refiner* (June).
- Scheiman, A.D. 1963. Size vapor-liquid separators quicker by nomograph. *Hydrocarbon Processing and Petroleum Refiner* (October).
- Scheiman, A.D. 1964. Horizontal vapor-liquid separators. *Hydrocarbon Processing and Petroleum Refiner* (May).
- Scotland, W.B. 1963. Discharge temperature considerations with multicylinder ammonia compressors. *Modern Refrigeration* (February).
- Scotland, W.B. 1970. Advantages, disadvantages and economics of liquid overfeed systems. *ASHRAE Symposium Bulletin* KC-70-3, Liquid overfeed systems.
- Soling, S.P. 1971. Oil recovery from low temperature pump recirculating hydrocarbon systems. *ASHRAE Symposium Bulletin* PH-71-2, Effect of oil on the refrigeration system.
- Sonders, M. and G.G. Brown. 1934. Design of fractionating columns, entrainment and capacity. *Industrial & Engineering Chemistry* (January).
- Stoecker, W.F. 1960. How to design and operate flooded evaporators for cooling air and liquids. *Heating, Piping & Air Conditioning* (December).
- Younger, A.H. 1955. How to size future process vessels. *Chemical Engineering* (May).

BIBLIOGRAPHY

- Chaddock, J.B. 1976. Two-phase pressure drop in refrigerant liquid overfeed systems—Design tables. *ASHRAE Transactions* 82(2):107-133.
- Chaddock, J.B., H. Lau, and E. Skuchas. 1976. Two-phase pressure drop in refrigerant liquid overfeed systems—Experimental measurements. *ASHRAE Transactions* 82(2):134-150.
- Geltz, R.W. 1967. Pump overfeed evaporator refrigeration systems. *Air Conditioning, Heating & Refrigeration News* (January 30, February 6, March 6, March 13, March 20, March 27).
- Lorentzen, G. and A.O. Baglo. 1969. An investigation of a gas pump recirculation system. *Proceedings of the Xth International Congress of Refrigeration*, p. 215. International Institute of Refrigeration, Paris.
- Richards, W.V. 1959. Liquid ammonia recirculation systems. *Industrial Refrigeration* (June):139.
- Richards, W.V. 1970. Pumps and piping in liquid overfeed systems. *ASHRAE Symposium Bulletin* KC-70-3, Liquid overfeed systems.
- Slipcevic, B. 1964. The calculation of the refrigerant charge in refrigerating systems with circulation pumps. *Kältetechnik* 4:111.
- Thompson, R.B. 1970. Control of evaporators in liquid overfeed systems. *ASHRAE Symposium Bulletin* KC-70-3, Liquid overfeed systems.
- Watkins, J.E. 1956. Improving refrigeration systems by applying established principles. *Industrial Refrigeration* (June).