

# CARGO CONTAINERS, RAIL CARS, TRAILERS, AND TRUCKS

<a href="#">Vehicles</a> .....	29.1
<a href="#">Vehicle Design Considerations</a> .....	29.1
<a href="#">Equipment</a> .....	29.3
<a href="#">Equipment Design and Selection Factors</a> .....	29.5
<a href="#">Qualification Testing</a> .....	29.7
<a href="#">System Application Factors</a> .....	29.8
<a href="#">Operations</a> .....	29.9

**T**RANSPORT of commodities may be as simple as direct delivery of fresh vegetables from garden to market in a wagon. However, travel time, ambient temperature, and risk of spoilage often make temperature-controlled transport necessary. Because some commodities are sensitive to the relative humidity and chemical composition of their surrounding atmosphere, these conditions may also need to be controlled. Today many commodities travel to distant markets intermodally, that is, by some combination of highway, ocean, and railroad. This chapter discusses the vehicles, equipment, and related factors that combine to preserve temperature-sensitive commodities as they travel.

Users are urged to regard the vehicle and its equipment as a system, particularly when making insulation and equipment sizing decisions.

## VEHICLES

Vehicles used for temperature-controlled transport are similar in construction and outward appearance to those in general freight service, but possess three fundamental differences: they have (1) insulation that is usually foamed in place, (2) provisions for conditioned air circulation through and around the cargo, and (3) machinery for cooling and/or heating. A brief description of the four main vehicle types follows.

Cargo containers range in size from 8 ft wide, 8 to 9.5 ft high, and are usually 20 or 40 ft long (Figure 1). They have hinged doors in one end for cargo loading and other access to the interior. The machinery comprises the opposite end, so it must also provide structural rigidity and insulation. As shown in Figure 1, containers have standardized corner fittings to secure them to vessels, railway cars, and highway vehicles; standards also govern their exterior dimensions. (Refer to ANSI Standard MH5.1.1.5 and ISO Standard 668.)

Railway refrigerator cars are insulated boxcars, usually 50 to 70 ft long (see Figure 2). As illustrated, they may have a machinery compartment at one end.

Trailers range in size from 8 to 8.5 ft wide, 12 to 13.5 ft high, and 24 to 55 ft long. Their doors are usually hinged, but they may have insulated roll-up doors if used for multistop delivery service. Some include a curbside door in addition to rear doors. Several interior compartments for different temperatures may be provided. For hanging uncut meat, overhead rails are used. Specially designed trailers riding on railway flat cars are quite common. Another, bimodal design can be mounted directly on specially configured railway bogies and pulled by a locomotive in a train of similar trailers.

Like ordinary trucks, those built for temperature-controlled duty come in a wide variety of designs and sizes. Their bodies may have

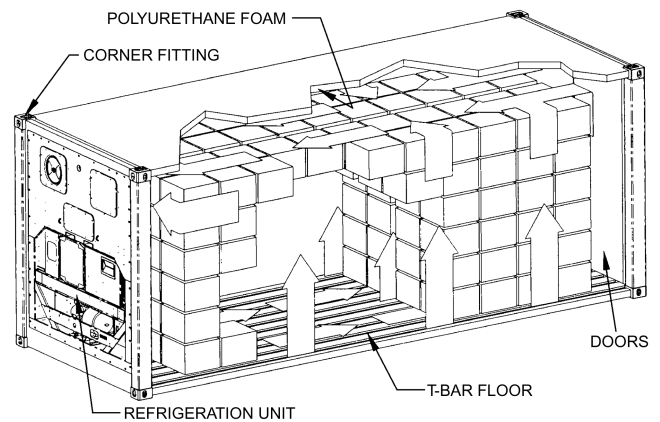

**Fig. 1 Refrigerated Cargo Container**

insulated hinged or roll-up doors; these may be on the sides and rear. Smaller vehicles may include a refrigeration compressor as an engine-driven accessory; see Mechanical Cooling and Heating in the section on Equipment.

## VEHICLE DESIGN CONSIDERATIONS

### Insulation and Vapor Barrier

Envelope design factors to be considered are similar to those for stationary refrigerated facilities, which include the following:

- Extremes of exterior conditions—temperature, relative humidity, wind, and solar effect
- Desired interior conditions—temperature and relative humidity
- Insulation properties—thermal conductivity, moisture permeability and retention, chemical and physical stability, adhesion, uniformity of application, fire resistance, cost of material and application, and presence of structural members
- Infiltration of air and moisture
- Tradeoffs between construction cost and operating expense

When applied to refrigerated vehicles, these five factors are complicated by others unique to transportation. Exterior dimension constraints are imposed by domestic or international standards and regulations, and shippers want maximum cargo space (which limits insulation thickness) and minimum tare weight. The frequency and duration of door openings may be considerable. Trips of long duration at highway or railway cruising speeds affect infiltration. Physical deterioration due to the shock and vibration of travel and cargo shifting is likely. Also, there is potential for damage to insulation and vapor barriers from vehicle accidents and cargo handling mishaps.

The preparation of this chapter is assigned to TC 10.6, Transport Refrigeration.



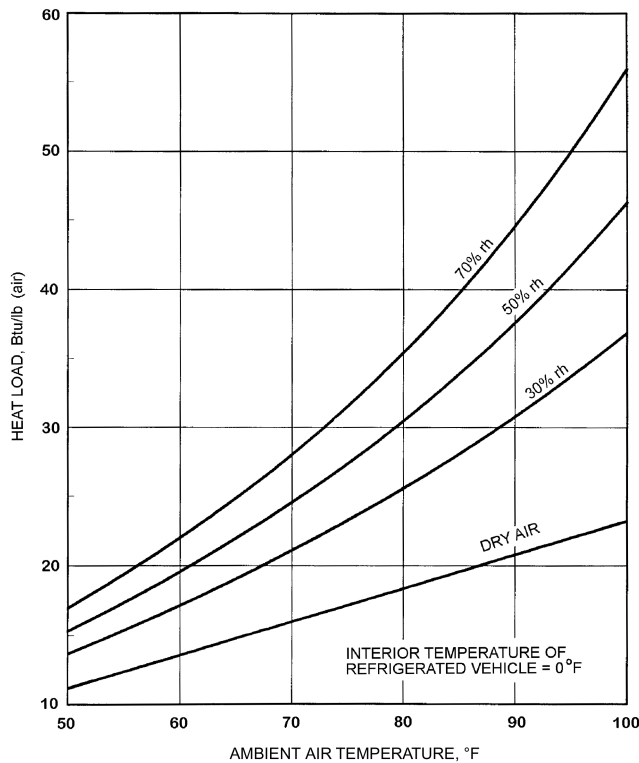

Fig. 3 Heat Load from Air Leakage

a vehicle 8 ft high with a 100°F difference is about 0.03 in. H<sub>2</sub>O (Phillips et al. 1960). Openings with an aggregate area of 1 in<sup>2</sup> each at the top and bottom would permit infiltration of about 120 ft<sup>3</sup>/h if assumed to be thin-plate orifices.

Eby and Collister (1955) discuss the infiltration load from air entering through cracks in the front of a moving vehicle. The ram air pressure is 1.21 in. H<sub>2</sub>O at 50 mph, and an exposed 1 in<sup>2</sup> opening can allow 1150 ft<sup>3</sup>/h of air to enter. At ambient conditions of 100°F and 50% rh and a vehicle temperature of 0°F, the extra infil-

tration load would be about 3800 Btu/h. Figure 3 provides heat gain into a 0°F vehicle resulting from infiltration of ambient air at various conditions.

**Air Circulation**

To avoid spoilage during transport,

- Surround the cargo with a flow of conditioned air sufficient to remove heat that enters the vehicle by conduction and infiltration. To do this, interior surfaces must have channels for flow of conditioned air. There may be space between the top of cargo and the ceiling, or flexible duct(s) in that space, or a fixed duct (false ceiling). Walls may have batten strips, or channels formed into the wall surfaces, or fixed ducts (false walls). The floor may have fixed longitudinal T-bars or “hat” sections, or movable racks.
- For commodities that respire or require in-transit cooling (e.g., fresh fruits, vegetables, and flowers), provide an adequate flow of conditioned air between and through packages. This process relies on the air circulation ability of the equipment (see Equipment Selection in the section on System Application Factors), and commodity loading practices (see Vehicle Usage Practices in the section on Operations).

Conditioned air may enter the cargo space over the top of cargo (normally used in rail cars, trailers, and trucks), or under the cargo (normally used in cargo containers). Figure 4 shows both methods using a trailer as an example.

**Equipment Attachment Provisions**

All components must be securely fastened to the vehicle to resist shock, vibration, and vandalism. Vehicle-to-equipment interfaces must have structure capable of secure support under all conditions of dynamic loading due to vehicle travel and equipment operation (e.g., engine and compressor vibration). Suitable fastening provisions (mounting holes, studs, or captive nuts) are needed. Wall openings for equipment, which may be large (e.g., the entire front wall of cargo containers), must have provisions to limit infiltration via gaskets, and sealing or caulking.

**Sanitation**

Vehicle internal cleanliness is enhanced by eliminating interior nooks and crannies where growth of fungi and bacteria can occur, and by using surfaces that tolerate cleaning materials such as hot

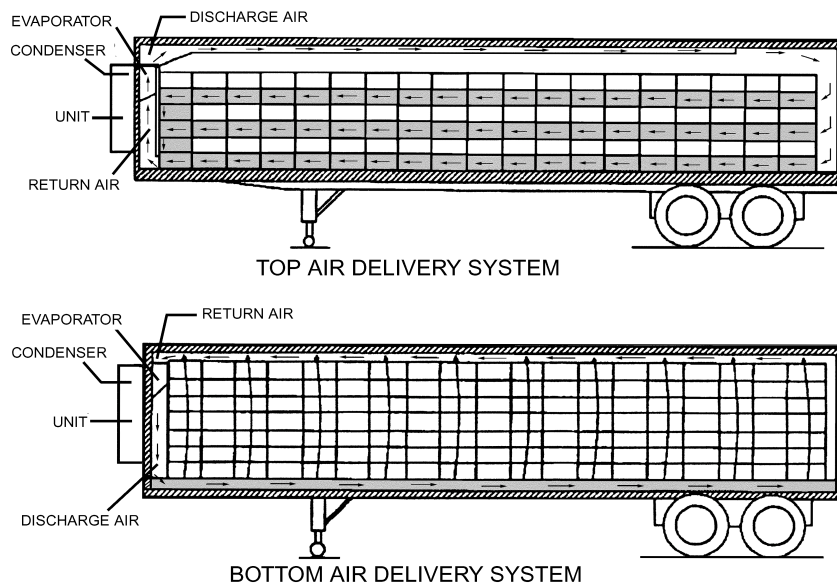

Fig. 4 Sections of Vehicle Showing Air Circulation

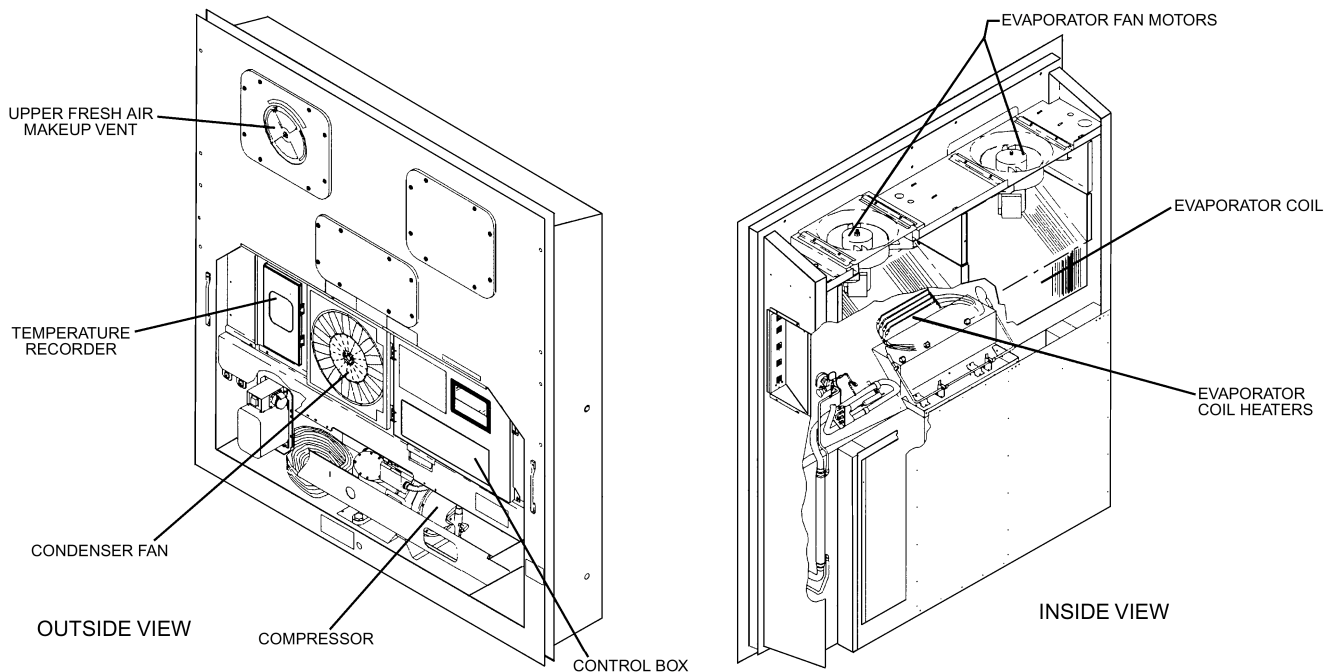

Fig. 5 Container Refrigeration Unit

water, disinfectants, detergents (including harsh cleaning solutions), and metal brighteners. Vehicle interiors should enable access to equipment components exposed to conditioned air (e.g., fans, cooling coils, and condensate pans) for periodic cleaning.

## EQUIPMENT

### Mechanical Cooling and Heating

Cargo containers typically have unitary equipment that comprises their entire front wall, provides structure and insulation, and is only about 16 in. thick. Figure 5 illustrates a typical unit. The equipment has a vapor compression refrigeration system and uses an external source of electricity for its compressor and fan motors, resistance heaters, and operating controls. It usually uses bottom air delivery as shown in Figure 4. The unit may have a detachable diesel engine-generator set (with integral fuel tank) accompany it while traveling by land.

Rail cars may have field-installed components. A three-phase ac diesel engine-generator set, condensing unit, and refrigerant and electrical operating controls are usually located in a machinery compartment at one end of the car. An evaporator fan-coil package, or separately mounted evaporator and fan, is typically adjacent to the machinery compartment but inside the insulated space. Electric heaters located in or under the evaporator are used for heating and defrost. This equipment usually uses top air delivery as shown in Figure 4. Fuel tanks are generally located under the car. Newer rail cars may use end-mounted unitary equipment similar to trailers.

Trailers typically have unitary equipment that consists of a diesel engine with battery charging alternator, compressor, condenser and engine radiator with fan, evaporator with fan, and refrigerant and electrical controls. It is installed on the front of the vehicle near the top over an opening that accommodates the evaporator and fan as shown in Figure 6. Top air delivery is usually used as shown here and in Figure 4. The fuel tank is placed under the trailer.

Large trucks typically have unitary equipment that is similar to trailer equipment, but more compact. Small trucks may have unitary equipment similar to that for large trucks, or field-installed

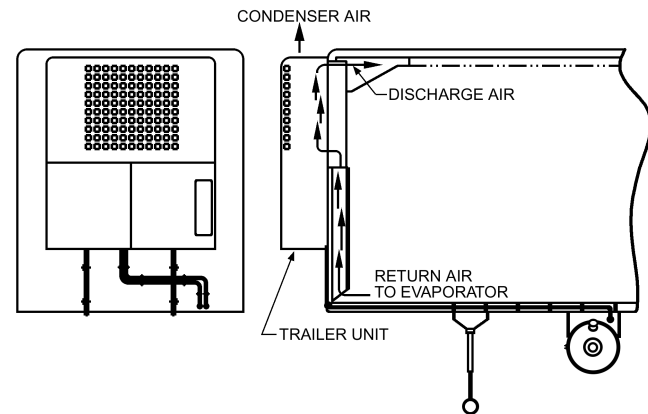

Fig. 6 Trailer Unit Installation

components. The latter, as shown in Figure 7, have a truck-engine-driven compressor. Also included is a condenser and evaporator fan-coil package; it is installed at the front top over an opening that accommodates the evaporator and its fan(s). (So it can be seen in this figure, the evaporator is shown shifted rearward.) Most of the refrigerant and electrical controls are usually also in this package. The controls and fan motors receive power from the truck's electrical system. Top air delivery is generally used as shown in Figure 4.

### Storage Effect Cooling

Although mechanical cooling now dominates, stored thermal energy is still occasionally used for transport of commodities.

Ice was the primary cooling means in rail cars for 100 years, but was phased out in most developed nations during the latter half of the twentieth century. When used, it is put in bunkers at each end of the car, and cargo cooling occurs by natural convection, or by forced convection using battery-powered fans that may be charged by axle-driven generators. Ice is still sometimes

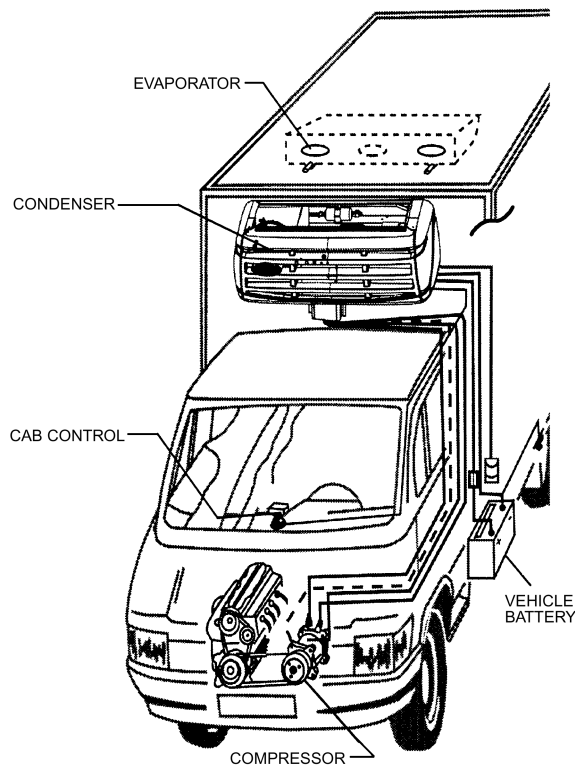

Fig. 7 Small Truck Refrigeration System

spread on top of rail car and trailer loads to supplement mechanical refrigeration in removal of field heat, or as an enhancement to mechanical refrigeration.

Solid carbon dioxide (dry ice) is sometimes used in small insulated boxes of very cold commodity. Liquid CO<sub>2</sub> or nitrogen, when used in vehicles, may be expanded directly into the cargo space. Sometimes CO<sub>2</sub> is evaporated in a heat exchanger that cools cargo compartment air, and the gas is exhausted outside. The fluids are carried in storage vessels located in or outside the refrigerated space. *Note:* All appropriate worker safety precautions must be observed to avoid asphyxiation hazards in the use of these coolants.

Eutectic plates are sometimes used in local delivery vehicles and are mounted on walls, ceilings, or both, or may be used as shelves or compartment dividers. Most have internal heat exchangers to enable recooling from a stationary or vehicle-mounted refrigeration system while the vehicle is not in motion.

The thermal storage effect of precooled milk or fruit juice, and some hot liquids, can hold the commodity within satisfactory temperature limits if carried in sufficiently insulated tanks.

### Heating Only

Commodities sensitive to low temperature are sometimes hauled in insulated vehicles with heating capability only. Direct-combustion heaters may be fueled by alcohol, butane, charcoal, kerosene, or propane. These are hazardous and must be appropriately designed and carefully used.

Engine-driven units, consisting of a diesel engine with battery charging alternator, engine-coolant heat exchanger, engine-driven fan, and operating controls, are available. They are installed on the front of the vehicle near the top, over an opening that accommodates the heat exchanger and fan. Top air delivery is typically used as shown in [Figure 4](#). The fuel tank is placed under the vehicle.

### Ventilation

Ventilation as a means of temperature control is usually accomplished by adjusting the opening of small doors at the front and rear to establish a flow of outside air through the vehicle. It is strictly limited by outdoor conditions. Ventilation is sometimes used with mechanical refrigeration to reduce the concentration of ripening gases in fresh commodities (see the section on Operations).

### Controlled and Modified Atmosphere

The benefits of controlled atmosphere (CA) and modified atmosphere (MA) are proportional to the duration of commodity exposure, so these supplements to mechanical refrigeration tend to be used when shipboard travel is involved. For further information, see Control of Atmospheric Chemistry in the Operations section.

Seagoing cargo container equipment sometimes has CA capability incorporated. Typical systems sense CO<sub>2</sub> and O<sub>2</sub> and are able to boost N<sub>2</sub> and/or CO<sub>2</sub> concentration in the cargo space, depending on commodity needs. Nitrogen levels are usually raised by passing a small flow of outside air through a N<sub>2</sub> separator, and venting O<sub>2</sub> and trace gases outside the vehicle. A supplemental supply of CO<sub>2</sub> is required to increase its concentration.

For short trips, or when replenishment is practical, MA may be used. It involves injecting an appropriate gas into the vehicle or into special commodity packaging, so it does not affect equipment design.

### Control Systems

Equipment control system functions normally include temperature control, defrost, and safety provisions. Cargo space return or supply (and sometimes both) air temperatures are monitored and thermostatically controlled. In addition to off/on operation of cooling and heating, more sophisticated systems include gradual capacity modulation to achieve a commodity temperature closer to the set point. Evaporator coil defrost may be initiated by sensing system performance parameters (e.g., evaporator airway pressure differential) or at timed intervals, and is usually terminated by sensing temperature on some part of the evaporator. Safety provisions essential to avoiding equipment damage and hazards to people are also incorporated.

Equipment control system functions may also include the following:

- Monitoring and displaying important operating parameters such as return air temperature
- Obtaining a detailed record of equipment performance during trips
- Providing alarms if unacceptable conditions occur
- Monitoring probes in the cargo space (e.g., for commodity pulp temperature)
- Stopping and starting engine-driven equipment, depending on the need for cooling or heating, to improve fuel economy
- Adjusting system capacity to match engine power capability during cargo space temperature pulldown and at different ambient temperatures
- Monitoring and controlling of cargo space atmospheric chemistry and relative humidity

Many of these control system functions are made practical by microprocessors. They enhance equipment response to varying operating conditions, such as ambient temperature. Their memory capability facilitates pretrip equipment operational checks, and enables tracking of equipment performance and analysis of possible malfunctions. Also, microprocessors can be used with radio telemetry to enable a central location to monitor thermostat setpoint, return and supply air temperature, operating mode, and alarm status.

Table 1 Typical Peak Shock Levels

Equipment	Peak Shock, $g^a$ by Axis		
	Vertical <sup>b</sup>	Longitudinal <sup>c</sup>	Lateral <sup>d</sup>
Containers			
Highway	9	2	4
Rail (on Flat Car)	7	7	3
Railway Cars			
Standard Draft Gear	9	14	5
Cushioned	7	7	3
Trailers/Trucks, Highway	9	2	4
Trailers, Railway			
On Flat Car	3	6	2
Bimodal <sup>e</sup>	9	6	5

<sup>a</sup>Acceleration of gravity, 32 ft/s<sup>2</sup> <sup>c</sup>Parallel to direction of travel  
<sup>b</sup>Up and down <sup>d</sup>Cross-wise of vehicle <sup>e</sup>See Vehicles section.

## EQUIPMENT DESIGN AND SELECTION FACTORS

This information is intended as a source of typical transportation duty guidelines for equipment design engineers. Specific applications may have more or less severe requirements. It is also intended to be useful to persons who select, specify, or apply this equipment.

### Time

Time is a design factor for some components. Two examples illustrate how it affects the objective of producing a robust system: (1) an oversized refrigerant filter-drier is often used because there may not be enough time for thorough refrigeration system evacuation during emergency service operations; moisture remaining in the system can be removed by one or more changes of a large filter-drier; (2) a large engine oil reservoir reduces the frequency of oil level inspections and extends time between oil changes without sacrificing engine reliability.

### Shock and Vibration

Shock and vibration are primary design concerns because equipment travels with the vehicle it serves, often includes an internal combustion engine, and may be subjected to occasional rough handling. Most system components are affected, but particular attention must be given to design of

- Structural frames
- Heavy component attachment
- Shock and vibration isolation devices
- Finned-tube heat exchangers
- Refrigerant piping (including capillaries) and its supports
- Refrigerant filter-driers
- Wiring supports and routing
- Electronic control devices
- Air impellers

[Table 1](#) provides general guidance to the engineer in establishing design load factors for structural calculations. Impacts of these magnitudes may occasionally occur during vehicle travel. The resulting forces transmitted to the equipment may be amplified or attenuated by the response of the intervening vehicle structure. Also, adjustment may be needed for local conditions (e.g., highways in very poor condition). Although  $g$ -levels under such conditions may be only slightly higher, the frequency of occurrence may be several times greater. [Table 1](#) is based on data in four reports prepared by the Association of American Railroads, or AAR (see the Bibliography).

Table 2 Ambient Temperatures for Equipment Design in Several Geographical Regions

	North					
	Asia	Europe	Mideast	America	Tropics	Global
Maximum, °F	120	110	125	120	110	125
Minimum, °F	-40	-30	-30	-40	30	-40

Vibration criteria are difficult to establish because of the many variables involved. For example, vehicle speed and road characteristics have an input that varies widely. Equipment manufacturers often have criteria based on their testing and experience.

It is good design practice to avoid equipment natural frequencies of 10 Hz or less (these are typical vehicle wheel rotation and suspension inputs). Also, the equipment should not have natural frequencies close to the firing frequency of the equipment's engine, pumping frequency of the compressor, or rpm of any of its rotating components (see the section on Qualification Testing).

### Ambient Temperature Extremes

Ambient temperature is a primary design consideration because equipment must be able to start, run, and perform under conditions that may include summer desert, summer tropical, and winter near-arctic. Many items are affected, but particular attention must be given to design of

- Heat exchangers using ambient air as a heat sink
- Other components dependent on ambient air for cooling, especially motors, alternators and generators, and electronic devices
- Systems relying on heat of refrigerant compression for heating or evaporator defrost
- Components that include elastomers and plastics, whose physical properties may be degraded
- Engine cranking motors, to account for engine oil viscosity increases and battery voltage decreases during cold weather

Typical ambient temperature maximum and minimum values for several geographic areas are provided as a guide for equipment design. Some vehicles (e.g., cargo containers) may travel anywhere, and their equipment should be designed for global extremes. Others, such as delivery trucks, usually have equipment designed for local conditions only. Engine starting below  $-20^{\circ}\text{F}$  may be difficult and require special procedures, but equipment operation can be required to heat the vehicle at very low ambient temperatures.

The values in [Table 2](#) were selected from [Chapter 27 of the ASHRAE Handbook—Fundamentals](#) with the likelihood of vehicular equipment operation in the area considered. Caution is required when using climatic design information because (1) more extreme temperatures may be encountered at locations in the region that are some distance from the station where data are taken, (2) higher transient values of  $135^{\circ}\text{F}$  or more may occur due to recirculation in sheltered areas or heat rejected from other nearby sources (see the section on Safety).

### Other Ambient Design Factors

Precipitation—snow, hail, rain and freezing rain—affects electric motors, and electrical component enclosures and cable connections.

Sea water, salt-laden sea air, and wintertime road salt tend to corrode metal parts. These include electric motors, compressors, and electrical enclosures and cable connections. Salt also affects finned-tube heat exchangers, air impellers, fasteners, structural frames, and sheet metal parts.

Air pollutants (such as sulfur dioxide in the diesel engine exhaust of the vehicle and equipment) combined with atmospheric moisture

can also contribute to degradation of metals, especially aluminum or copper-finned heat exchangers.

Interior air quality is also important. Some materials, including plastics and elastomers, may emit chemical odors that adversely affect the taste and smell of certain foods. Their use in parts exposed to conditioned air should be avoided. British Standards Institute (BSI) *Standard 3755*, known as the butter taint test, may be used to check this aspect of a material's suitability.

Dirt and debris are common along highways and railways and inside cargo spaces. Also encountered are insects and fluff from vegetation. Equipment designs must exclude these materials from critical components where possible, and include provisions for essential cleaning in both vehicles and equipment.

Solar radiation is unavoidable. Some components may be affected by ultraviolet radiation, including paint, plastics, and elastomers; some may also be sensitive to heat. Solar radiation also contributes to the cooling load (see Load Calculations in the section on System Application Factors).

Vandalism and theft can occur, and are difficult to thwart. Among the concerns are storage batteries, electrical cables, and other components with obvious salvage value.

Equipment to be used internationally may have to meet the anti-smuggling requirements of the *TIR Handbook* (UN 1988). For example, ventilation (outside-air) ports in cargo container units include sturdy screens.

### Operating Economy

This is a complex consideration that includes reliability, serviceability, and fuel or power consumption.

Equipment should be reliable because

- It may be preserving a high-value commodity.
- It often operates unattended during trips.
- It frequently travels far from knowledgeable service technicians, repair parts, and supplies of refrigerant and other operating fluids.

Laboratory and field experience must be combined to demonstrate the durability of operating components; the ability of the system to start, run, and perform under all expected ambient conditions; and structural integrity.

Good equipment serviceability is important for the same three reasons. Components and assemblies should be designed for easy access. This is important for testing and trouble analysis, routine maintenance, and repair or replacement of components.

Another factor peculiar to transportation refrigeration service is the availability, when and where needed, of knowledgeable service technicians, repair parts, and supplies. The supplies include suitable fuel; the exact refrigerant for which the system is designed; lubricants specified for the compressor, engine, and other components; and engine coolant.

Fuel (or power) consumption has an obvious role. Among items that affect it are the thermodynamic and mechanical efficiencies of engines, motors, compressors, and power transmission devices. The thermodynamic performance of condensers and evaporators has a major role, as do system provisions for part-load operation. The aerodynamic efficiency of air impellers and related flow paths has an effect, too.

### Airborne Sound

Sound may be a concern when residential and commercial areas about or government-imposed sound limits exist. Design and selection considerations include using the following:

- Engines, compressors, and air impellers that are inherently relatively quiet
- Acoustical treatments and sound attenuation features that are durable and likely to remain in use

### Safety

Safety in transport equipment is of concern because cargo handlers, vehicle operators, and service technicians are often close to the equipment. Also, at times the general public may be near refrigerated vehicles. Although there are no known safety codes specifically for transport equipment, those mentioned in this section are sufficiently general in scope to apply, or good engineering practice suggests their use for guidance.

All potentially dangerous parts, including fans, belts, rotating parts, hot surfaces, and electrical items, require appropriate guards, enclosures, and/or warning labels. Labels should emphasize universally understandable graphics; suitable designs can be provided by the International Organization for Standardization (ISO) or similar groups.

Refrigerant pressure vessels must comply with applicable safety codes; some often-used codes are listed here:

- American Society of Mechanical Engineers *Boiler and Pressure Vessel Code, Section VIII* (ASME 2001), for vessels larger than 6 in. inside diameter
- European Committee for Standardization (CEN) Pressure Equipment Directive 97/23/EC
- CEN *Standard* EN 378-2:2000
- Underwriters Laboratories (UL) *Standard* 1995—vessels of 6 in. or less inside diameter

Refrigeration system design pressures should account for worst-case temperature extremes for any intended application of equipment. As the presence of some liquid is likely, either by design or from excess refrigerant in the system, saturation pressures are used.

Under nonoperating conditions, usually 150°F (saturation) is used for low and high sides, based on new product shipping experience. Vehicles standing still in the sun without wind should meet this criterion as well. *Note:* Shipping package design and storage practices must recognize potential excessive temperature hazards. For example, equipment covered with plastic shrinkwrap may experience temperatures greater than 150°F when left in direct sunlight.

While operating, the low side is unlikely to exceed the nonoperating criterion. The high-side criterion of 150°F (saturation) is based on the nonoperating value because the worst-case high-side value, from ASHRAE *Standard* 15-1994, par. 9.2.1(c), is lower. For example,

- 130°F Europe worst case: Sevilla, Spain at 100°F 1% db
- 139°F North America worst case: Yuma, AZ at 109°F 1% db
- 145°F Mideast worst case: Kuwait, Kuwait at 115°F 1% db

High-side saturation temperature excursions above 150°F can result from the 135°F (or more) transients cited in Ambient Temperature Extremes. For example, 155°F is sometimes used for trailer equipment.

The choice of over-pressure protection in the high side, as for a liquid receiver, also affects the design pressure.

**Example 1.** What design pressures are required if a pressure relief device (valve or rupture disk) is used, or if a fusible plug is used? The highest normal pressure for a R-134a system high side, assuming 155°F transient exposure, is 281 psig. The critical pressure for R-134a is 574 psig).

#### Solutions:

*Pressure relief device:* The recommended 25% margin between relief pressure and the highest normal pressure (to avoid accidental discharge) raises minimum relief pressure from 281 to 351 psig. Therefore, a design pressure of 355 psig is appropriate. Pressure vessel testing at 1.25 or 1.5 times design pressure is required by major safety codes.

*Fusible plug:* The design pressure must be 281 psig or greater. So, a design pressure of 285 psig is appropriate. If a fusible plug with a nominal setting of 173°F is chosen, the corresponding nominal release pressure is 354 psig. Some codes (e.g., UL *Standard* 1995) require pressure

vessel testing at 2.5 times the nominal release pressure or the critical pressure, whichever is less; in this example, 2.5 times release pressure (in psia) would be used.

Safety codes (e.g., ANSI/ASHRAE *Standard* 15-1994) require overpressure protection such as a relief valve, rupture disk, or fusible plug. Also required is a pressure limiting device (i.e., a high pressure switch to stop compressor operation). Overpressure protection design decisions must consider possible regional or local regulations that reflect environmental concerns. Rupture disk discharge to atmosphere may be prohibited in some areas unless in series with a relief valve. Fusible plugs may be prohibited in some areas unless connected to the low-pressure side.

### QUALIFICATION TESTING

This section provides an overview of testing usually done by equipment manufacturers to determine if equipment meets operating design criteria, and endures and performs satisfactorily in the transportation environment. Prospective users may wish to be guided by evidence of successful completion of appropriate tests, or may wish to consider special testing of their own.

Operational tests are done to establish the ability of equipment to provide satisfactory control of temperature in a typical vehicle, especially at set points between 30 and 60°F. Tests normally include cooling and heating, with ambient temperatures above, at, and below each set point. Operation over the entire range of ambient and internal temperatures expected for the intended vehicles is also tested.

Psychrometric testing is appropriate because cargo space relative humidity affects nonfrozen commodity desiccation. Desiccation is limited by keeping the evaporator surface temperature as high as possible by its thermodynamic design and by refrigeration capacity control methods. In some equipment, additional control is achieved by sensing relative humidity and atomizing water into the conditioned air stream as needed to maintain the desired level for commodity storage.

It is also necessary to verify operation of other equipment functions, such as defrost effectiveness and evaporator fan performance (static pressure vs. flow). If controlled atmosphere is an equipment option, its effectiveness may need to be checked.

For equipment rating purposes, refrigeration capacity is normally determined at the following conditions:

- 100°F ambient in North America, and 86°F in Europe
- 35, 0, and -20°F cargo space (return air) in North America, and 32 and -4°F in Europe

Capacity may be certified to meet ARI *Standard* 1110 or other industry standards. Most qualification testing programs will also include establishing capacity at other conditions as well.

Heating capacity (if not electric resistance) is usually, as a minimum, tested at 0°F ambient and 35°F cargo space (return air).

Shock and vibration qualification demonstrates that equipment meets guidelines presented in the Equipment Design and Selection Factors section. A search is made for natural frequencies of 10 Hz or less, and for any that are close to the firing frequency of the equipment's engine, pumping frequency of the compressor, or rpm of any of its rotating components. This testing may be done on laboratory apparatus that shakes equipment in each of its three primary axes. Endurance testing usually follows using an amplitude and frequency spectrum based on field experience. A special test for cargo container equipment imposes typical lateral (racking) and end loading forces. Field trials are essential; they usually take several months, and are followed by disassembly and thorough inspection. Some redesign may be needed; testing should be repeated as needed to confirm its success.

Testing at extremes of ambient temperature (and sometimes relative humidity) extremes testing is usually done on major mechanical and electrical components by their suppliers (including engines,

compressors, motors, alternators, generators, solenoids, and electronic devices). It is also done on complete equipment in test chambers capable of operation over the temperature ranges expected for both high and low sides. Of particular interest is the ability of equipment to start and run at ambient and cargo space extremes, and evaporator defrosting performance.

Qualification for other ambient design factors generally includes the following:

- Rain testing is usually done by component suppliers on items such as electric motors. It is also done on complete equipment to check integrity of electrical cabinets and cable entries.
- Components susceptible to ocean environment corrosion, especially for cargo containers, are laboratory tested in specially designed salt-spray apparatus.
- Visual inspection and experience-based judgment are usually used for items like potential for clogging with dirt and debris, and susceptibility to vandalism and theft.
- Items exposed to sunlight, including elastomers, plastics, labels, and paints, are laboratory tested for ultraviolet resistance.

### SYSTEM APPLICATION FACTORS

As noted in the introduction, users of this information are urged to regard the vehicle and its equipment as a system. This section provides guidance for that design effort. Three steps are recommended.

#### Load Calculations

The objective of load calculations in this application is to determine average conduction and infiltration loads per hour. Familiarity with [Chapter 12](#) will be helpful.

The vehicle's heat transfer factor ( $UA$ ) should be determined. If more than one insulation system is being considered (e.g., several thicknesses), there will be a  $UA$  factor for each. This information is normally available from the vehicle manufacturer. It may be calculated with guidance from [Chapter 12](#) and confirmed (or determined) by test.

Typical vehicle travel time (hours) is needed. For long hauls, add the vehicle's stationary time at each end while loaded with the equipment operating. The time for short hauls is usually a typical working day.

Determine the range of average ambient temperatures the vehicle is likely to encounter. (See Ambient Temperature Extremes in the section on Equipment Design and Selection Factors) The range of commodity types and temperatures the vehicle is likely to encounter must also be known.

Solar radiation may be approximated using data in [Table 3 of Chapter 12](#). For example, assume the vehicle roof and one side are exposed to the sun. Divide the sum of the products of areas and temperatures by the total area to get an adjusted ambient temperature. (If this were included in Example 2, the ambient temperature would be about 3°F higher, increasing conduction and infiltration about 6%, and total load about 4%.)

Infiltration through the vehicle body and closed doors is usually included in the  $UA$  value. Infiltration during door openings is not, however. This is a significant consideration for delivery vehicles; estimates may be made using information from vehicle or equipment manufacturers.

Vehicle aging effects should be considered: the ability to protect low-temperature commodities will decrease with time. Insulation and door seal deterioration can increase  $UA$  by 25% or more in vehicles older than 3 years.

The cooling load calculations in Example 2 include commodity temperature pull-down and heat of respiration. Both of these vary widely with the type of commodity and its treatment before loading into the vehicle. Some commodities (e.g., frozen goods and meat), have no heat of respiration. Recommended practices include pre-

cooling or preheating the vehicle to bring its interior surfaces to the planned thermostat setting; that load is ignored. Also ignored are the minor loads associated with cooling (1) the air not displaced by the commodity and (2) its packaging materials; both have relatively low mass and poor thermal conductivity.

**Example 2.** Determine the conduction and infiltration load, commodity temperature pulldown load, commodity heat of respiration, total load, and average load for the following shipment:

Vehicle  $UA$  factor: 155 Btu/h·°F  
 Vehicle travel time: 72 h (3 days)  
 Assumed average ambient temperature: 85°F  
 Initial average commodity temperature: 40°F  
 Final average commodity temperature: 34°F  
 Assumed average commodity temperature en route: 37°F  
 Thermostat setting temperature: 36°F  
 Commodity: Elberta peaches  
 Quantity: 38,000 lb (19 tons)  
 Specific heat above freezing: 0.9 Btu/lb·°F (from [Table 3 of Chapter 8](#))  
 Heat of respiration at 37°F: 1169 Btu/24h-ton (from [Table 9 of Chapter 8](#), interpolated)

**Solutions:**

Conduction and infiltration load  
 $(155)(72)(85 - 36) = 546,840$  Btu  
 Commodity temperature pulldown load  
 $(0.9)(38,000)(6) = 205,200$  Btu  
 Commodity heat of respiration =  $(1169)(19)(3) = 66,633$  Btu  
 Total load for trip = 818,673 Btu  
 Average load =  $818,673/72 = 11,370$  Btu/h

*Note:* One vehicle insulation system was assumed in this example; if several are to be compared, iterations with the different  $UA$  factors are required.

If cold-weather travel is likely, do a similar calculation for the heating load. In this calculation average ambient temperature should ignore solar radiation. Commodity temperature pulldown load may be nil. Heat of respiration of the commodity will reduce the total and average loads.

## Equipment Selection

The selection of equipment from manufacturer's product data begins with matching its cooling and heating capacity to new vehicle needs, as determined by load calculations. It may include consideration of aging effects on vehicle  $UA$  (see the note following the example in Load Calculations), and equipment cooling and heating capacity.

Also important is the equipment's ability to properly control cargo space conditions, especially temperature. If relative humidity and/or atmospheric chemistry control options are being considered, their effectiveness needs review.

Microprocessors, multiple temperature sensors, and sophisticated equipment capacity controls enable close control of air temperatures, some to  $\pm 0.5^\circ\text{F}$  of desired temperature. Depending on the level of system sophistication, it is possible to control either return or supply temperature, or both. Maintaining suitable return air temperature is essential for all commodities. Control of supply air temperature helps prevent freezing damage to commodities like fruits and vegetables.

Evaporator fan performance also has a role in control of cargo space temperature, and to some extent, cargo space relative humidity. Airflow should be adequate to ensure that the commodity is surrounded by air at the proper temperature, and to minimize the supply-to-return air temperature difference. Fan static pressure must be sufficient to force air through the distribution system and cargo. Also, the evaporator may be partially frosted, which suggests the need to have fans with steep characteristic curves (static pressure vs. flow).

Evaporator defrost effectiveness should be judged under frozen load conditions. It must be initiated when needed and must be thorough, to avoid ice buildup on the evaporator.

Details of vehicle selection are beyond the scope of this chapter, but it should be guided by the section on Vehicle Design Considerations. Three items in Equipment Design and Selection Factors also affect vehicle selection: Shock and Vibration, Ambient Temperature Extremes, and Other Ambient Design Factors.

Operating economy data for life cycle cost analysis should be obtained during the selection process for both the vehicle and equipment. Some of these data (e.g., fuel or power consumption at various operating conditions) may be available from manufacturers. Some, such as annual cost of emergency service, preventive maintenance, repair parts, and supplies, will come from user records and experience. Other data such as cost of fuel or power may have to be forecasts.

## Owning and Operating Costs

[Chapter 36 of the ASHRAE Handbook—HVAC Applications](#) discusses this topic in detail for HVAC systems, and its contents may be adapted for vehicles and equipment used for transport of commodities. [Table 1](#), Owning and Operating Cost Data and Summary, in that chapter can be modified to suit. Item I is the total of vehicle and equipment cost. Item V requires deleting factors that do not apply. Other factors peculiar to the transportation business may need to be added to either owning or operating costs. Once established for a particular vehicle-equipment combination, calculations may be replicated for trade-off comparisons of vehicle and equipment options. These might include insulation thickness, fuel economy, and vehicle revenue.

Some cost comparison of vehicle and equipment choices is usual in procurement processes. Its level of sophistication may depend on one or more of the following:

- Availability of information
- Size of planned procurement
- Management requirements for decision making
- Familiarity with engineering economic analysis techniques

Two of the possible cost comparison choices follow:

**Life-cycle cost analysis:** See [Chapter 36 of the ASHRAE Handbook—HVAC Applications](#). It would include each combination of vehicle and equipment options, and have a column similar to [Table 1](#) in that chapter for each year of useful life. This method accounts for the time value of money.

**First-year-only analysis:** For each combination of vehicle and equipment options, comparisons would be made of initial cost, estimated fuel or power cost, and expected vehicle revenue. Organization of information as in [Table 1 in Chapter 36 of the ASHRAE Handbook—HVAC Applications](#) will be useful.

## OPERATIONS

### Commodity Precooling

Ideally, every commodity should be brought to its optimum storage temperature quickly and held there until it is placed in the vehicle. Otherwise there will be effects on commodity quality ranging from slight to significant. This topic is addressed in more detail in chapters on food refrigeration in this volume and other publications on refrigerated transport (see the References and Bibliography).

Should a commodity be loaded at a temperature above optimum, the vehicle's equipment will attempt to reduce it during transit (see Example 2). If the shipping carton design and loading pattern provide good air circulation around the commodity, and if the equipment has adequate cooling capacity, eventually the commodity temperature will approach the thermostat setting. However, any time spent away from optimum storage temperature makes some

loss of product quality inevitable. Therefore, regular reliance on vehicle refrigeration equipment to compensate for bad practices in precooling, storage, and loading is not recommended.

### Vehicle Usage Practices

Cleanliness of vehicle interiors, including conditioned air paths, is essential to food commodity safety and quality. It avoids bacterial, chemical, and odor contamination, and in some cases (e.g., transport of fresh meat products) may be required by government food safety regulations. Regular cleaning and sanitizing is recommended; details appear in publications such as *Guide to Refrigerated Transport* (IIR 1995) and *Protecting Perishable Foods During Transport by Truck* (Ashby 2000).

Precool the closed vehicle to the desired commodity temperature before loading. In cold weather, preheat for fresh commodities. This may take several hours under extreme ambient temperature conditions. However, precooling or preheating helps avoid overwhelming the equipment's capacity and possible damage to portions of the cargo. *Note:* To avoid significant frost buildup on the evaporator, do not operate equipment in the cooling mode when loading at an open, unrefrigerated dock.

Prompt cargo transfer between refrigerated warehouses and vehicles is important to maintenance of product quality. Ideally, loading and unloading should be done using refrigerated dock areas. When this is not possible, commodity movement methods and packaging that help minimize exposure to warm air (or very cold air for fresh commodities) become very important.

Commodity loading practices are an important factor in helping equipment maintain good temperature distribution within the cargo. Main points to remember include the following:

- Use packages and stack heights that avoid crushing (which blocks airflow between packages)
- Provide spaces between packages for airflow through the load
- Leave adequate space between ceiling and cargo for airflow
- Support cargo away from walls and doors so that air, rather than the commodity, absorbs transmitted heat

For further information, see IIR (1995) and Ashby (2000).

Commodity arrangement is important in delivery vehicles that have frequent door openings to unload cargo. Items to be removed at the first scheduled stop should be located close to the door(s) to expedite unloading and minimize open door time. Next in the arrangement should be the items for the second stop, then the third, etc.

### Temperature Settings

The cargo space must be held close to a temperature that helps maintain commodity quality and provides desired shelf life at its destination. This volume, as well as IIR (1995) and Ashby (2000), are good sources for the recommended storage temperatures for various commodities. Because these sources draw from several sets of research and field experience, there are minor differences in the recommendations, but using any of them (or other similarly reliable sources) should yield good results. Users sometimes create their own tables of settings based on the work of others and experience with shipments.

Thermostat settings for nonfrozen commodities must be chosen carefully to avoid possible damage due to lengthy exposure to subfreezing evaporator air discharge temperature. The following example is related to the Load Calculations example, and shows that portions of the commodity exposed to the supply air stream could suffer freezing damage.

**Example 3.** Determine the approximate supply air temperature (SAT), at both full and reduced refrigeration capacities, for the following shipment:

Return air temperature: 36°F

Refrigeration capacity: 48,000 Btu/h

Refrigeration capacity, reduced by equipment's capacity control: 13,000 Btu/h

Evaporator airflow: 3,000 cfm

Approximate specific heat of air: 0.24 Btu/lb·°F

Approximate density of air: 0.075 lb/ft<sup>3</sup>

Commodity: Elberta peaches

Initial freezing point: 30.4°F

#### Solution:

SAT (full capacity)

$$36 - [48,000/(3,000)(60)(0.24)(0.075)] = 21.2^{\circ}\text{F}$$

SAT (reduced capacity)

$$36 - [13,000/(3,000)(60)(0.24)(0.075)] = 32^{\circ}\text{F}$$

As discussed in the section on Control Systems and Equipment Selection, equipment with microprocessors and sophisticated capacity controls is able to achieve very close air (and commodity) temperature control. Some equipment can control both return and supply air temperatures.

### Other Cargo Space Considerations

The number of days spent in a refrigerated vehicle determines whether fresh commodities benefit significantly from ventilation, or control of relative humidity and/or cargo space atmospheric chemistry. Because their itineraries often include lengthy sea voyages, cargo containers are more likely to need one or more of the three following provisions.

### Ventilation

Cargo container equipment may include means to admit outside air to reduce concentration of gases, primarily ethylene and CO<sub>2</sub>, that are produced by fresh product respiration. Their outside air openings are adjustable and usually calibrated for several air exchange rates. Some container users publish suggested rates for various fresh products, ranging from 15 to 150 cfm. Information may be available from local growers cooperatives, agricultural universities, and similar organizations. References with specific ventilation recommendations could not be located.

Other vehicles, such as trailers, sometimes have small doors in their front and rear to admit and exhaust air as discussed in the section on Equipment. If ambient temperatures are moderate, a few products (such as unripened honeydew melons) may be transported with ventilation only.

### Relative Humidity Control

Equipment, particularly for cargo containers, may have relative humidity sensing and control capability. Lengthy trips may make humidification desirable to help limit commodity desiccation. To maintain sanitary conditions within the cargo space, it is essential that potable water be put in the humidifier reservoir. Some equipment may have provisions to automatically replenish the reservoir with condensate from evaporator defrost operation. For further information, see [Chapters 16 to 28](#) in this volume, Nichols (1985), and Ashby (2000).

### Control of Atmospheric Chemistry

The chemistry of the cargo space atmosphere may affect fresh product quality at its destination. Commodity respiration, the combining of natural sugars with oxygen, can be slowed by reducing the ambient O<sub>2</sub> level. Increasing the CO<sub>2</sub> level slows respiration further, and helps prevent premature aging. Specific combinations of gases will control, and in some cases eliminate, certain pathogens and insects. Also, texture and color can be maintained by limiting ethylene, a natural ripening agent. Each product has unique physiological characteristics that dictate specific O<sub>2</sub> and CO<sub>2</sub> levels. Depending on travel time, monitoring and control of these levels can be critical to maintenance of product quality. Ashby (2000) only provides recommendations for berries and cherries (perhaps because most truck

and trailer trips are of a few days' duration); a 10 to 20% CO<sub>2</sub> atmosphere is normally used as a mold retardant.

For long hauls, especially in seagoing cargo containers, controlled atmosphere capability may be needed. As discussed in the Equipment section, CO<sub>2</sub> and O<sub>2</sub> are sensed. The N<sub>2</sub> and/or CO<sub>2</sub> concentrations in the cargo space are adjusted, depending on commodity needs.

On short hauls, or when replenishment from a stationary source while en route is practical, modified atmosphere may be used. The entire vehicle may be treated after loading, but requires a seal of plastic film at the doorway(s), successive purging operations to drive out much of the air, and injection of the gas treatment. Sometimes pallet loads of commodity are sealed, evacuated, and injected with the appropriate gas.

For further information, including advice on control settings, see Nichols (1985), Kader et al. (1992), and Hardenburg et al. (1990). Also see [Chapter 10](#), Commodity Storage Requirements, in this volume.

## Maintenance

Successful operations depend on regular pretrip inspections and scheduled maintenance. Prompt action to correct vehicle or equipment deficiencies is required. *Note:* All appropriate safety precautions must be taken during pretrip and scheduled maintenance work.

Proper vehicle maintenance helps ensure system effectiveness in preserving temperature-sensitive commodities. Periodic inspection—preferably before each trip—is essential. It should include the following:

- Attachment of equipment components: correct loose or damaged fasteners
- Insulation, vapor barrier, and door seals: repair or replace damaged areas
- Air distribution system (ducts): repair or replace damaged parts
- Evaporator condensate outlets: clear drain lines and replace or correct faulty air traps
- Floor drains: repair or correct faulty air traps
- Interior cleanliness (discussed in the preceding section on Vehicle Usage Practices)

Equipment maintenance items may be categorized as pretrip and scheduled. Manufacturer's operation and service manuals provide valuable guidance on both. All who use and maintain equipment should be thoroughly familiar with them and follow all of their instructions carefully. Highlights typical of these manuals follow:

### Pretrip Inspection (usually daily)

- Physical appearance of equipment components: repair or replace as required
- Evaporator, condenser, and engine radiator (if used): clean if air flow or heat transfer are obstructed
- Evaporator condensate drain: clean if obstructed, check and service drain trap if faulty
- Refrigerant moisture indicator (if used): service if "wet" indication occurs
- Refrigerant charge level: if low, check for and repair leaks; add proper refrigerant as needed
- Compressor oil level: unlike engines, compressors do not consume oil, and addition should only be needed if a refrigerant leak or service procedure has resulted in loss
- Engine oil and coolant levels: if low, check for and repair leaks; add proper fluid as needed
- Check all equipment functions (microprocessor controls usually do this automatically): if any are faulty, troubleshoot and repair

*Scheduled Maintenance* (inspect and service, following the equipment manual's instructions)

- Mechanical and electrical components, including
  - Fasteners, latches, hinges, and covers (and their gaskets, if any)
  - Gauges, switches, and electrical connections

- Belts and shaft couplings
- Fans
- Refrigeration system components, including
  - Evaporator and condenser: airflow and heat transfer must not be obstructed
  - Evaporator condensate drain: must be clear and air traps in good working order
  - Filter-drier: must not be clogged (no detectable temperature drop across it)
  - Refrigerant moisture indicator (if used): must indicate "dry"
  - Refrigerant charge level: must be within normal limits
  - Compressor oil level: must be within normal limits
  - System operation in all modes: cooling, heating, and defrost must work properly
  - Operating pressures and temperatures: must be within normal limits
- Engine systems (if engine driven), including
  - Lubrication: no leaks; change oil and filter as required
  - Cooling: no leaks; airflow and heat transfer must not be obstructed; change coolant as required
  - Fuel system: no leaks; change filter(s) as required
  - Exhaust: no leaks; sound level must be normal
  - Combustion air: service and change filter as required
  - Starting: cranking motor engagement must be normal
  - Battery charging: output must be normal

## REFERENCES

- ANSI. 1990. Road/rail closed dry van containers. *ANSI Standard MH5.1.1.5-1990* (R1997). American National Standards Institute, New York.
- ANSI/ASHRAE. 1994. Safety code for mechanical refrigeration. *ANSI/ASHRAE Standard 15-1994*. American Society of Heating, Refrigerating and Air-Conditioning Engineers.
- ARI. 1992. Mechanical transport refrigeration units. *ARI Standard 1110-92*. Air-Conditioning and Refrigeration Institute, Arlington, VA.
- Ashby, B.H. 2000. Protecting perishable foods during transport by truck. *Handbook* 669. U.S. Department of Agriculture, Washington, D.C.
- ASME. 2001. *Boiler and pressure vessel code, section VIII*. American Society of Mechanical Engineers, New York, NY.
- BSI. 1964. Methods of test for the assessment of odour from packaging materials used for foodstuffs. *BSI Standard BS 3755:1964*. British Standards Institution, London.
- CEN. 1997. Pressure equipment directive 97/23/EC. *Document 397L0023*. European Committee for Standardization, Brussels.
- CEN. 2000. Refrigerating systems and heat pumps—Safety and environmental requirements—Part 2: Design, construction, testing, marking and documentation. *Standard EN 378-2:2000*. European Committee for Standardization, Brussels.
- Eby, C.W. and R.L. Collister. 1955. Insulation in refrigerated transportation body design. *Refrigerating Engineering* (July):51.
- Hardenburg, R.E., A.E. Watada, and C.Y. Wang. 1990. The commercial storage of fruits, vegetables, and florist and nursery stocks. *Agriculture Handbook* 66. USDA.
- IIR. 1995. *Guide to refrigerated transport*. International Institute of Refrigeration, Paris.
- ISO. 1995. Series 1 freight containers—Classifications, dimensions and ratings, 4th ed. *ISO Standard 668:1995*. International Organization for Standardization, Geneva.
- Kader, A.A., R.F. Kasmire, F.G. Mitchell, M.S. Reid, N.F. Sommer, and J.F. Thompson. 1992. Postharvest technology of horticultural crops. *Special Publication* 3311. Cooperative Extension, University of California, Division of Agriculture and Natural Resources.
- Nichols, C.J. 1985. Export handbook for U.S. agricultural products. *Agriculture Handbook* 593. U.S. Department of Agriculture, Washington, D.C.
- Phillips, C.W., et al. 1960. A rating method for refrigerated trailer bodies hauling perishable foods. *Marketing Research Report No. 433*. Agricultural Marketing Service, U.S. Department of Agriculture, Washington, D.C.

- UL. 1995. Heating and cooling equipment. *UL Standard 1995* (2nd ed.). Underwriters Laboratories, Northbrook, IL.
- UN. 1988. *TIR handbook*. ECE/TRANS/TIR/1. Economic Commission for Europe (Geneva), United Nations, New York.

### BIBLIOGRAPHY

- AAR. 1987. *Environmental analysis—Yard handling of TOFC traffic*. File 204/400. Association of American Railroads, Washington, D.C.
- AAR. 1991. *A technical summary of the intermodal environment study*. Report No. DP 3-91. Association of American Railroads, Washington, D.C.
- AAR. 1992a. *Study of the railroad shock and vibration environment for roadtrailer equipment*. Report No. DP 1-92. Association of American Railroads, Washington, D.C.
- AAR. 1992b. Multi-level environment study with Ford Motor Company. Report No. DP 4-92. Association of American Railroads, Washington, D.C.
- AFDO. *Guidelines for the transportation of food*. Association of Food and Drug Officials, York, PA.
- IIR. 1985. Long distance refrigerated transport—Land and sea. International Institute of Refrigeration, Paris.
- IIR. 1985. Technology advances in refrigerated storage and transport. International Institute of Refrigeration, Paris.
- IIR. 1986. Recommendations for the processing and handling of frozen foods. International Institute of Refrigeration, Paris.
- IIR. 1992. Compression cycles for environmentally acceptable refrigeration, air conditioning and heat pump system. International Institute of Refrigeration, Paris.
- IIR. 1993. Cold store guide. International Institute of Refrigeration, Paris.
- IIR. 1994. New applications of refrigeration to fruit and vegetables processing. International Institute of Refrigeration, Paris.
- IIR. 1995. Refrigeration and the quality of fresh vegetables. International Institute of Refrigeration, Paris.
- IIR. 1996. New developments in refrigeration for food safety and quality. International Institute of Refrigeration, Paris.
- IIR. 1996. Refrigeration, climate control and energy conservation. International Institute of Refrigeration, Paris.
- IIR. 1996. Research, design and construction of refrigeration and air conditioning equipment in Eastern European countries. International Institute of Refrigeration, Paris.
- Mercantila Publishers. 1993. Guide to food transport. July.
- Mercantila Publishers. 1995. Guide to refrigerated transport. September.
- Ryall, A.L. and W.J. Lipton. 1972. *Handling transportation, and storage of fruits and vegetables, Vol. 1*. AVI Publishing, Westport, CT.
- Ryall, A.L. and W.T. Pentzer. 1982. *Handling transportation, and storage of fruits and vegetables, Vol. 2—Fruits and tree nuts*, 2nd ed. AVI Publishing, Westport, CT.
- Sinclair, Joseph. 1999. *Refrigerated transportation*. Witherby & Co. Ltd., London.