

# REFRIGERANT-CONTROL DEVICES

<a href="#"><u>CONTROL SWITCHES</u></a> .....	45.1	<a href="#"><u>Suction-Pressure-Regulating Valves</u></a> .....	45.14
<a href="#"><u>Pressure Switches</u></a> .....	45.1	<a href="#"><u>Condenser-Pressure-Regulating Valves</u></a> .....	45.14
<a href="#"><u>Temperature Switches (Thermostats)</u></a> .....	45.2	<a href="#"><u>Discharge Bypass Valves</u></a> .....	45.15
<a href="#"><u>Differential Switches</u></a> .....	45.2	<a href="#"><u>High-Side Float Valves</u></a> .....	45.16
<a href="#"><u>Float Switches</u></a> .....	45.3	<a href="#"><u>Low-Side Float Valves</u></a> .....	45.16
<a href="#"><u>CONTROL SENSORS</u></a> .....	45.4	<a href="#"><u>Solenoid Valves</u></a> .....	45.17
<a href="#"><u>Pressure Transducers</u></a> .....	45.4	<a href="#"><u>Condensing Water Regulators</u></a> .....	45.19
<a href="#"><u>Thermistors</u></a> .....	45.4	<a href="#"><u>Check Valves</u></a> .....	45.21
<a href="#"><u>Resistance Temperature Detectors</u></a> .....	45.4	<a href="#"><u>Relief Devices</u></a> .....	45.21
<a href="#"><u>Thermocouples</u></a> .....	45.4	<a href="#"><u>DISCHARGE-LINE LUBRICANT SEPARATORS</u></a> .....	45.23
<a href="#"><u>CONTROL VALVES</u></a> .....	45.4	<a href="#"><u>CAPILLARY TUBES</u></a> .....	45.23
<a href="#"><u>Thermostatic Expansion Valves</u></a> .....	45.4	<a href="#"><u>Adiabatic Capillary Tube Selection Procedure</u></a> .....	45.26
<a href="#"><u>Electric Expansion Valves</u></a> .....	45.10	<a href="#"><u>Capillary Tube-Suction Line Heat Exchanger Selection Procedure</u></a> .....	45.28
<a href="#"><u>REGULATING AND THROTTLING VALVES</u></a> .....	45.10	<a href="#"><u>SHORT-TUBE RESTRICTORS</u></a> .....	45.30
<a href="#"><u>Evaporator-Pressure-Regulating Valves</u></a> .....	45.11		
<a href="#"><u>Constant-Pressure Expansion Valves</u></a> .....	45.13		

**T**HE control of refrigerant flow is essential in any refrigeration system.

Most examples, references, and capacity data in this chapter refer to the more common refrigerants.

For further information on control fundamentals, see [Chapter 15, Fundamentals of Control, of the ASHRAE Handbook—Fundamentals](#) and [Chapter 46, Design and Application of Controls, of the ASHRAE Handbook—HVAC Applications](#).

## CONTROL SWITCHES

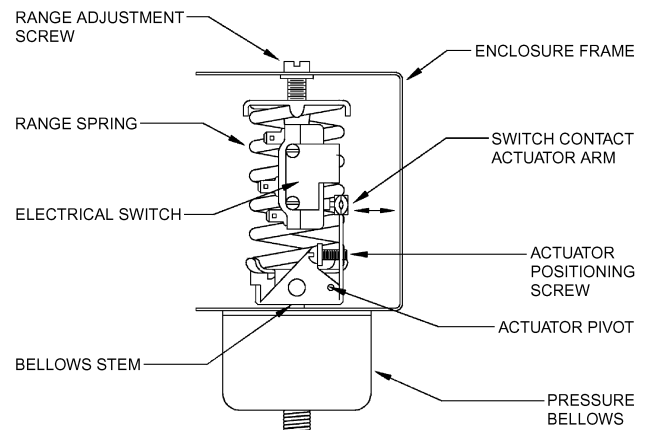
The control switch is a device that includes both a sensor and a switch mechanism capable of opening and/or closing an electrical circuit in response to changes in the monitored parameter. The control switch operates one or more sets of electrical contacts, which are used, for example, to open or close water or refrigerant solenoid valves, engage and disengage automotive compressor clutches, or activate and deactivate relays, contactors, magnetic starters, and timers. Control switches respond to a variety of physical changes, such as pressure, temperature, and liquid level.

Liquid-level-responsive controls may use floats, mercury balance tubes, or electronic probes to operate (directly or indirectly) one or more sets of electrical contacts.

Refrigeration control switches may be categorized into three basic groups: (1) operating, (2) primary, and (3) limit. Operating controls, such as thermostats, turn systems on and off. Primary controls provide safe continuous operation such as compressor or condenser fan cycling. Limit controls, such as the high-pressure cut-out switch, protect a refrigeration system from unsafe operation.

### PRESSURE SWITCHES

Pressure-responsive switches have one or more power elements (e.g., bellows, diaphragms, or bourdon tubes) to produce the force needed to operate the mechanism. Typically, pressure switch power elements are all metal, although some miniaturized devices for specific applications, such as automotive air conditioning, may employ synthetic diaphragms. The refrigerant pressure is applied directly to



**Fig. 1 Typical Pressure Switch**

the element, which moves against a spring that can be adjusted to control an operation at the desired pressure ([Figure 1](#)). If the control is to operate in the subatmospheric (or vacuum) range, the bellows or diaphragm force is sometimes reversed to act in the same direction as the adjusting spring.

The force available for doing work in this control switch depends on the pressure in the system and on the area of the bellows or diaphragm. With proper area, a sufficient force can be produced to operate heavy-duty switches. In switches for high-pressure service, the minimum differential is relatively large because of the high gradient range spring required.

Miniaturized pressure switches may incorporate one or more snap disks, which provide positive snap action of the electrical contacts. Use of snap disk construction ensures consistent differential pressure between on and off settings (see [Figure 2](#)). Another important benefit of snap disk construction is the substantial reduction in electrical contact bounce or flutter, which can damage compressor clutch assemblies, relays, and electronic control modules. Some snap disk switches are built to provide multiple functions in a single unit, such as high-pressure cut-out (HPCO), high-side low-pressure (HSLP), and high-side fan cycling (HSFC) switches.

Pressure switches in most refrigeration systems are used primarily to start and stop the compressor, cycle condenser fans, and

The preparation of this chapter is assigned to TC 8.8, Refrigerant System Controls and Accessories.

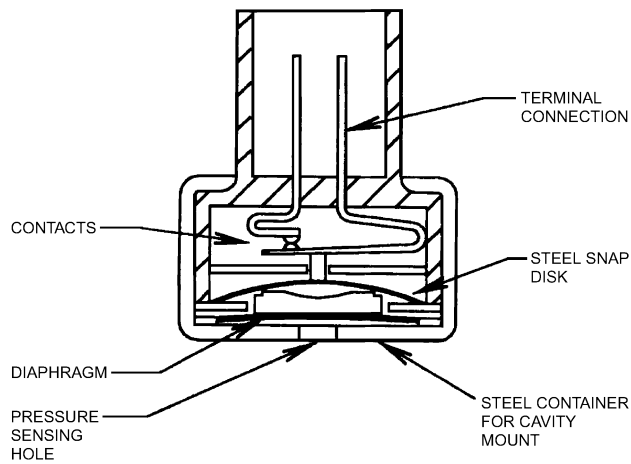


Fig. 2 Miniaturized Pressure Switch

Table 1 Various Types of Pressure Switches

Type	Function
High-pressure cut-out (HPCO)	Stops compressor when excessive pressure occurs
High-side low-pressure (HSLP)	Prevents compressor operation under low ambient or loss of refrigerant conditions
High-side fan cycling (HSFC)	Cycles condenser fan on and off to provide proper condenser pressure
Low-side low-pressure (LSLP)	Initiates defrost cycle; stops compressor when low charge or system blockage occurs
Low-side compressor cycling (LSCC)	Cycles compressor on and off to provide proper evaporator pressure and load temperature
Lubricant pressure differential failure (LPDF)	Stops compressor when difference between oil pressure and crankcase pressure is too low for adequate lubrication

initiate and terminate defrost cycles. [Table 1](#) shows various types of pressure switches with their corresponding functions.

### TEMPERATURE SWITCHES (THERMOSTATS)

Temperature-responsive switches have one or more metal power elements (e.g., bellows, diaphragms, bourdon tubes, bimetallic snap disks, or bimetallic strips) that produce the force needed to operate the switch.

An **indirect temperature switch** is a pressure switch with the pressure-responsive element replaced by a temperature-responsive element. The temperature-responsive element is a hermetically sealed system comprised of a flexible member (diaphragm or bellows) and a temperature-sensing element (bulb or tube) that are in pressure communication with each other ([Figure 3](#)). The closed system contains a temperature-responsive fluid.

The exact temperature-pressure or temperature-volume relationship of the fluid used in the element allows the temperature of the bulb to control the switch accurately. Operation of the switch results from changes in pressure or volume that are proportional to changes in sensor temperature.

A **direct temperature switch** typically contains a bimetallic disk or strip that activates electrical contacts when the temperature increases or decreases. As the temperature of a bimetallic disk or strip in the switch increases or decreases, the bimetallic element bends or strains due to the two metals' different coefficients of thermal expansion, and the linked electrical contacts engage or disengage. The disk bimetallic element provides snap action, which results in rapid and positive opening or closing of the electrical contacts, minimizing arcing and bounce. The bimetallic strip element ([Figure 4](#)) produces very slow contact action and is only suitable for use in very low

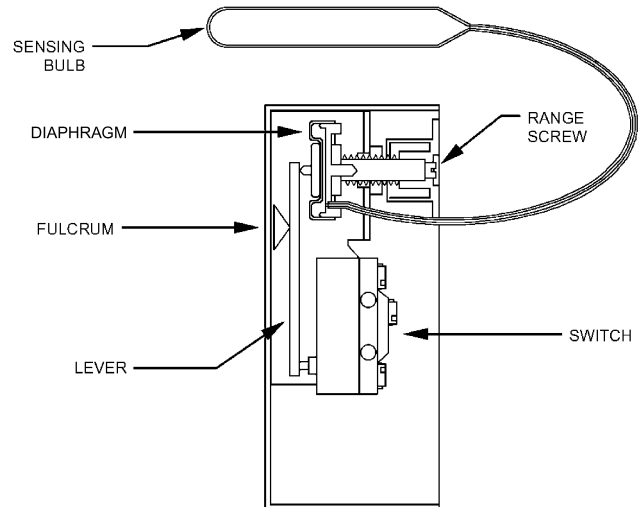


Fig. 3 Indirect Temperature Switch

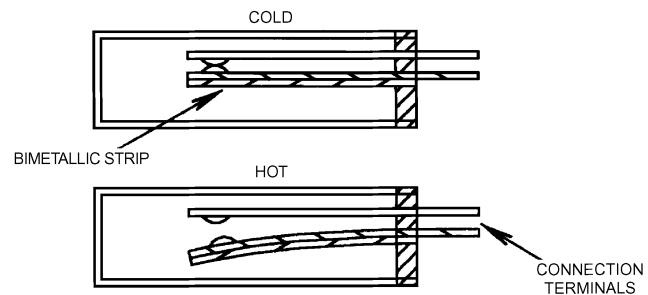


Fig. 4 Direct Temperature Switch

thermal limit control because the switch differentials and precision may be inadequate for many primary refrigerant control requirements.

### DIFFERENTIAL SWITCHES

Differential control switches typically maintain a given difference in pressure or temperature between two pipelines, spaces, or loads. An example is the lubricant pressure differential failure switch used with reciprocating compressors employing forced-feed lubrication.

[Figure 5](#) is a schematic of a differential switch that uses bellows as power elements. [Figure 6](#) describes a differential pressure switch that has been used to protect compressors against low oil pressure. These controls have two elements (either pressure- or temperature-sensitive) sensing conditions in two locations. As shown, the two elements are rigidly connected by a rod so that motion of one causes motion of the other. The connecting rod operates contacts (as shown). The scale spring is used to set the differential pressure at which the device operates. At the control point, the sum of the forces developed by the low-pressure bellows and the spring balances the force developed by the high-pressure bellows.

**Instrument differential** is the difference in pressure between the low- and the high-pressure elements for which the instrument is adjusted. In the case of a temperature element, this difference is expressed in degrees. **Operating differential** is the change in differential pressure or temperature required to open or close the switch contacts. It is actually the change in instrument differential from cut-in to cut-out for any setting. Operating differential can be varied by a second spring that acts in the same direction as the first

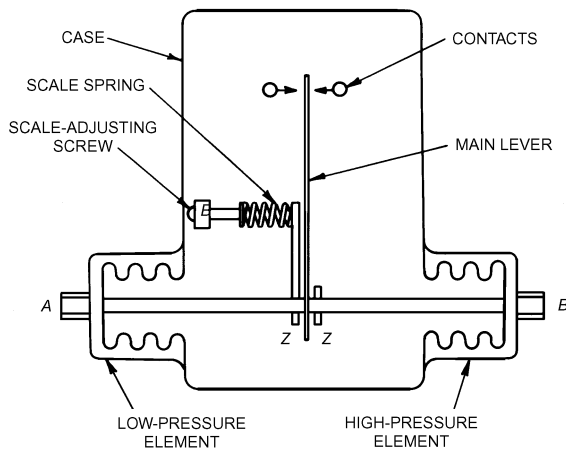


Fig. 5 Differential Switch Schematic

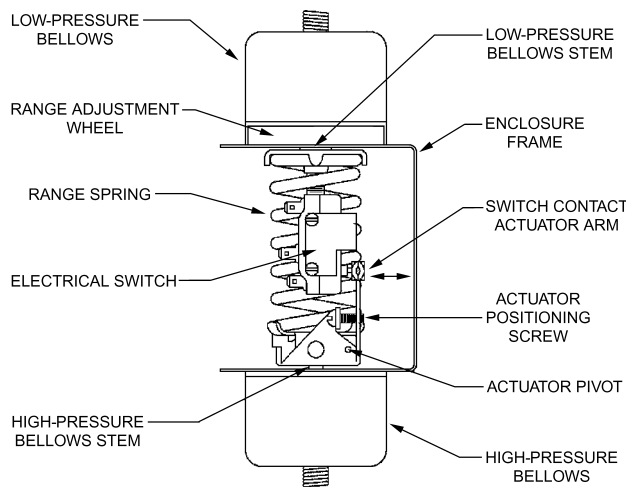


Fig. 6 Differential Pressure Switch

and takes effect only at the cut-in or cut-out point without affecting the other spring. A second method is the adjustment of the distance between collars Z-Z on the connecting rod. The greater the distance between them, the greater the operating differential.

If a constant instrument differential is required on a temperature-sensitive differential control switch throughout a large temperature range, one element may contain a different temperature-responsive fluid than the other.

A second type of differential-temperature control uses two sensing bulbs and capillaries connected to one bellows with a liquid fill. This is known as a constant-volume fill, because the operating point depends on a constant volume of the two bulbs, capillaries, and bellows. If the two bulbs have equal volume, a rise in the temperature of one bulb requires an equivalent fall in the temperature of the other to maintain the operating point.

**FLOAT SWITCHES**

A float switch has a float that operates one or more sets of electrical contacts as the level of a liquid changes. It may be connected by equalizing lines to the vessel in which the liquid level is to be maintained or indicated.

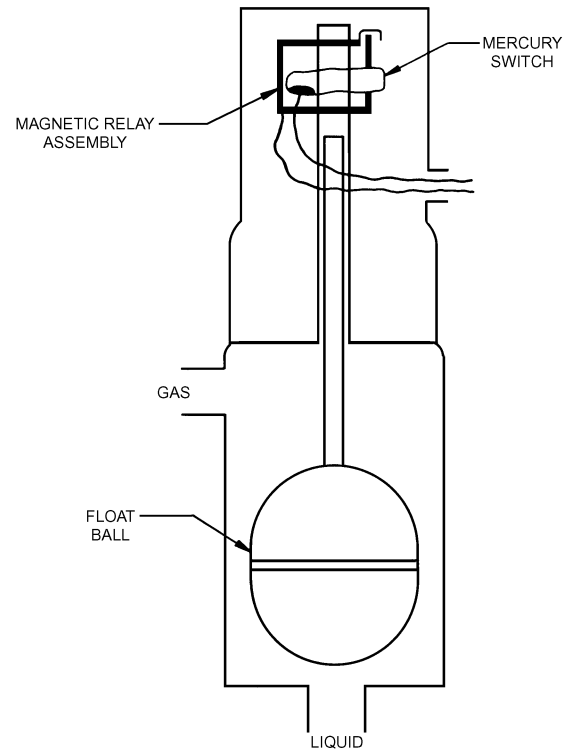


Fig. 7 Magnetic Float Switch

**Operation and Selection**

Some float switches (Figure 7) operate from the movement of a magnetic armature located in the field of a permanent magnet. Others use solid-state circuits in which a variable signal is generated by liquid contact with a probe that replaces the float. The latter methods are adapted to remote-controlled applications and are preferred for ultralow-temperature applications. Switches that have mercury-tube contacts are usually not recommended for installation in an ambient temperature lower than -25°F, because mercury freezes at approximately -38°F.

**Application**

The float switch can maintain or indicate the level of a liquid, operate an alarm, control the operation of a pump, or perform other functions. A float switch, solenoid liquid valve, and hand expansion valve combination can control the refrigerant level on the high- or low-pressure side of the refrigeration system in the same way that high- or low-side float valves are used. The hand expansion valve, located in the refrigerant liquid line immediately downstream of the solenoid valve, is initially adjusted to provide a refrigerant flow rate at maximum load to keep the solenoid liquid valve in the open position 80 to 90% of the time; it need not be adjusted thereafter. From the outlet side of the hand expansion valve, the refrigerant passes through a line and enters either the evaporator or the surge drum.

When the float switch is used for low-pressure level control, precautions must be taken to provide a calm liquid level that falls in response to an increase in evaporator load and rises with a decrease in evaporator load. The same recommendations for insulation of the body and liquid leg of the low-pressure float valve apply to the float switch when it is used for refrigerant-level control on the low-pressure side of the refrigeration system. To avoid floodback in this application, controls should be wired to prevent the solenoid liquid valve from opening when the solenoid suction valve closes or the compressor stops.

## CONTROL SENSORS

The control sensor is the component in a control system that measures and signals the value of a parameter but has no direct function control. Control sensors typically require an auxiliary source of energy for proper operation. They may be integrated into electronic circuits that provide the required energy and condition the sensor's signal to accomplish the desired function control.

### PRESSURE TRANSDUCERS

Pressure transducers sense refrigerant pressure through a flexible element (diaphragm, bourdon tube, or bellows) that is exposed to the system refrigerant pressure. The pressure acts across the flexible element's effective area, producing a force that causes the flexible element to strain against an opposing spring within the transducer. The transducer employs a potentiometer, variable capacitor, strain gage, or piezo element to translate the flexible element's movement to a proportional electrical output.

Transducers typically include additional electronic signal processing circuitry used to temperature-compensate, modify, amplify, and linearize the final analog electrical output. Typically, the outside of the pressure-sensing flexible element is exposed to atmospheric pressure and the transducer's electrical output is proportional to the gage pressure of the refrigerant. Transducers capable of measuring absolute pressure are also available.

Transducers are usually used as control sensors in electronic control systems where the continuous analog pressure signal provides data to comprehensive algorithm-based control strategies. For example, in automotive air conditioning systems, engine load management can be significantly enhanced. Based on a correlation between refrigerant pressure and compressor torque requirements, the vehicle electronic engine controller uses the transducer signal to regulate the engine air and fuel flow compensating for compressor load variations. This improves fuel economy and eliminates the "power drain" experienced when the compressor starts.

### THERMISTORS

Thermistors are cost-effective and reliable temperature control sensors. They are typically small and are available in a variety of configurations and sheath materials. Thermistors are beads of semiconductor materials with electrical resistances that change with temperature. Materials with negative temperature coefficients (NTC) (e.g., the resistance decreases as the temperature increases) are frequently used. NTC thermistors typically produce large changes in resistance with relatively small changes of temperature, and their characteristic curve is nonlinear ([Figure 8](#)).

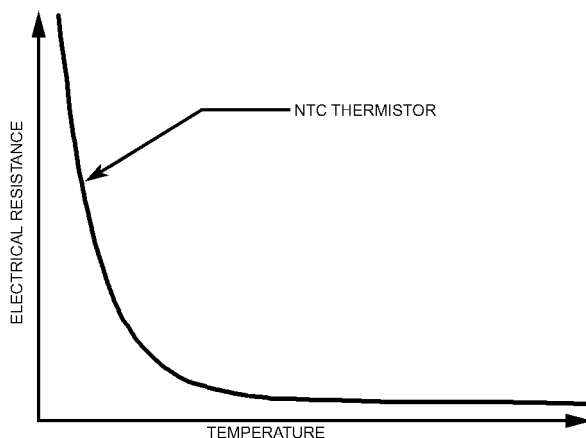


Fig. 8 Typical NTC Thermistor Characteristic

Thermistors are used as control sensors in electronic control systems that linearize and otherwise process their resistance change into function control actions such as driving step motors or bimetallic heat motors for function modulation. Their analog signal can also be conditioned to perform start-stop functions such as energizing relays, contactors, or solenoid valves.

### RESISTANCE TEMPERATURE DETECTORS

Resistance temperature detectors (RTDs) are made of very fine metal wire or films coiled or shaped into forms suitable for the application. The elements may be mounted on a plate for surface temperature measurements or encapsulated in a tubular sheath for immersion or insertion into pressurized systems. Elements made of platinum or copper have linear temperature-resistance characteristics over limited temperature ranges. Platinum, for example, is linear within 0.3% from 0 to 300°F and minimizes long-term changes due to corrosion. RTDs are often mated with electronic circuitry that produces a 4 to 20 mA current signal over a selected temperature range. This arrangement eliminates error associated with connecting line electrical resistance.

### THERMOCOUPLES

Thermocouples are formed by the junction of two wires of dissimilar metals. An electromotive force dependent on the wire material and the junction temperature exists between the wires. When the wires are joined at both ends, a thermocouple circuit is formed. When the junctions are at different temperatures an electric current flows through the circuit. The current that flows through the circuit is proportional to the temperature difference between the two junctions. One junction, called the cold junction, is kept at a constant known temperature (e.g., in an ice bath). The temperature of the other (hot) junction is then determined by measuring the net voltage in the circuit. Electronic circuitry is often arranged to provide a built-in cold junction and linearization of the net voltage-to-temperature relationship. The resulting signal can then be electronically conditioned and amplified to implement function control.

### CONTROL VALVES

Control valves are used to start, stop, direct, and modulate the flow of refrigerant to satisfy system requirements in accordance with load requirements. To ensure satisfactory performance, valves should be protected from foreign material, excessive moisture, and corrosion by properly sized strainers, filters, and/or filter-driers.

### THERMOSTATIC EXPANSION VALVES

The thermostatic expansion valve controls the flow of liquid refrigerant entering the evaporator in response to the superheat of the gas leaving the evaporator. It functions to keep the evaporator active without permitting liquid to return through the suction line to the compressor. This is done by controlling the mass flow of refrigerant entering the evaporator so it equals the rate at which it can be completely vaporized in the evaporator by the absorption of heat. Because this valve is operated by superheat and responds to changes in superheat, a portion of the evaporator must be used to superheat the refrigerant gas.

Unlike the constant-pressure valve, the thermostatic expansion valve is not limited to constant-load applications. It is used for controlling refrigerant flow to all types of direct-expansion evaporators in air-conditioning, commercial, low-temperature, and ultralow-temperature refrigeration applications.

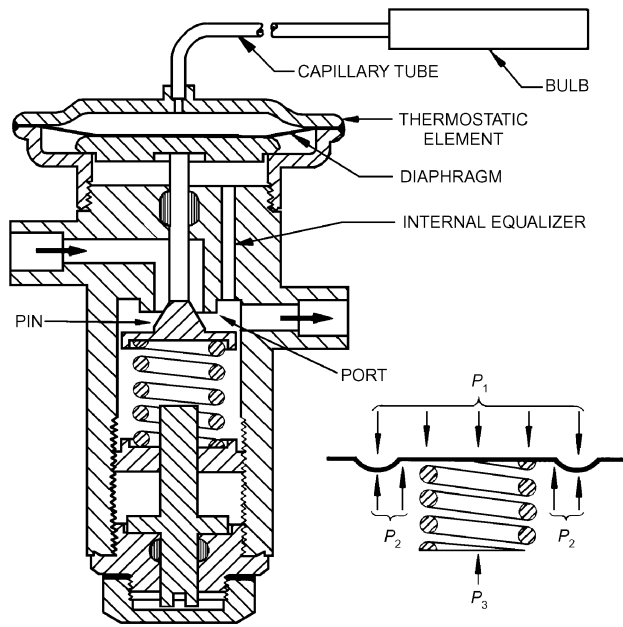


Fig. 9 Typical Thermostatic Expansion Valve

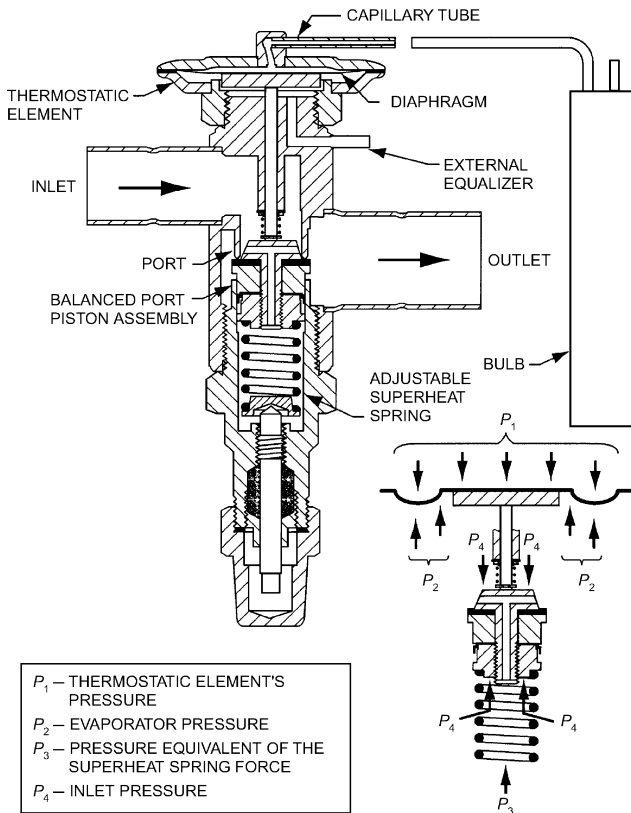


Fig. 10 Typical Balanced Port Thermostatic Expansion Valve

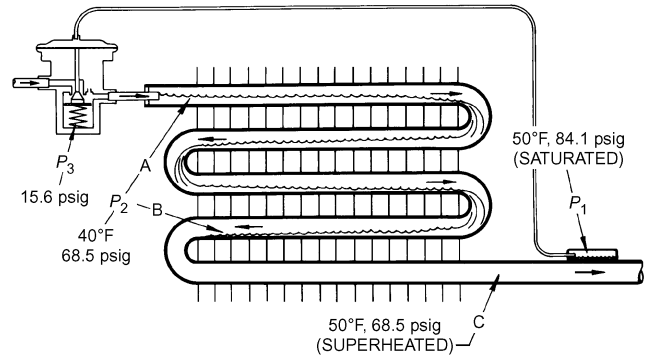


Fig. 11 Thermostatic Expansion Valve Controlling Flow of Liquid R-22 Entering Evaporator, Assuming R-22 Charge in Bulb

**Operation**

A schematic cross section of the typical thermostatic expansion valve, with the principal components identified, is shown in Figure 9. The following forces govern thermostatic expansion valve operation:

- $P_1$  = the pressure of the thermostatic element (a function of the bulb's charge and the bulb temperature), which is applied to the top of the diaphragm and acts to open the valve
- $P_2$  = the evaporator pressure, which is applied under the diaphragm through the equalizer passage and acts in a closing direction
- $P_3$  = the pressure equivalent of the superheat spring force, which is applied underneath the diaphragm and is also a closing force

At any constant operating condition, these forces are balanced and  $P_1 = P_2 + P_3$ .

An additional force, which is small and not considered fundamental, arises from the pressure differential across the valve port. To a degree, it can affect thermostatic expansion valve operation. For the configuration shown in Figure 10, the force resulting from port imbalance is the product of the pressure drop across the port and the area of the port; it is an opening force in this configuration. In other designs, depending on the direction of flow through the valve, the port imbalance may result in a closing force.

The principal effect of port imbalance is on the stability of valve control. As with any modulating control, if the ratio of the diaphragm area to the port is kept large, the unbalanced port effect is minor. However, if this ratio is small or if system operating conditions require, a balanced port valve can be used. Figure 10 shows a typical balanced port design.

Figure 11 shows an evaporator operating with R-22 at a saturation temperature of 40°F (68.5 psig). Liquid refrigerant enters the expansion valve, is reduced in pressure and temperature at the valve port, and enters the evaporator at Point A as a mixture of saturated liquid and vapor. As flow continues through the evaporator, more of the refrigerant is evaporated. Assuming there is no pressure drop, the refrigerant temperature remains at 40°F until the liquid is entirely evaporated at Point B. From this point, additional heat absorption increases the temperature and superheats the refrigerant gas, while the pressure remains constant at 68.5 psig, until, at Point C (the outlet of the evaporator), the refrigerant gas temperature is 50°F. At this point, the superheat is 10°F (50°F – 40°F).

An increase in the heat load on the evaporator increases the temperature of the refrigerant gas leaving the evaporator. The bulb of the valve senses this increase and the thermostatic charge pressure

$P_1$  increases and causes the valve to open wider. The increased flow results in a higher evaporator pressure  $P_2$  and a balanced control point is again established. Conversely, a decrease in the heat load on the evaporator decreases the temperature of the refrigerant gas leaving the evaporator and causes the thermostatic expansion valve to start closing.

The new control point, after an increase in valve opening, is at a slightly higher operating superheat because of the spring rate of the diaphragm and superheat spring. Conversely, a decrease in load results in an operating superheat slightly lower than the original control point.

These superheat changes in response to load changes are illustrated by the gradient curve of Figure 12. The superheat at no load, distance 0-A, is called static superheat and ensures sufficient spring force to keep the valve closed during system shutdown. An increase in valve capacity or load is approximately proportional to superheat until the valve is fully open. The opening superheat, represented by the distance A-B, may be defined as the superheat increase required to open the valve to match the load. Operating superheat is the sum of static superheat and opening superheat.

### Capacity

The factory superheat setting (static superheat setting) of thermostatic expansion valves is made when the valve starts to open. Valve manufacturers establish capacity ratings on the basis of opening superheat, typically from 4 to 8°F, depending on valve design, valve size, and application. Full-open capacities usually exceed rated capacities by 10 to 40% to allow a reserve, represented by the distance B-C in Figure 12, for manufacturing tolerances and application contingencies.

A valve should not be selected on the basis of its reserve capacity, which is available only at higher operating superheat. The added superheat may have an adverse effect on performance. Because valve gradients used for rating purposes are selected to produce optimum modulation for a given valve design, manufacturers' recommendations should be followed.

Thermostatic expansion valve capacities are normally published for various evaporator temperatures and valve pressure drops. (See ASHRAE *Standard 17* and ARI *Standard 750* for testing and rating methods.) Nominal capacities apply at 40°F evaporator temperature. Capacities are reduced at lower evaporator temperatures.

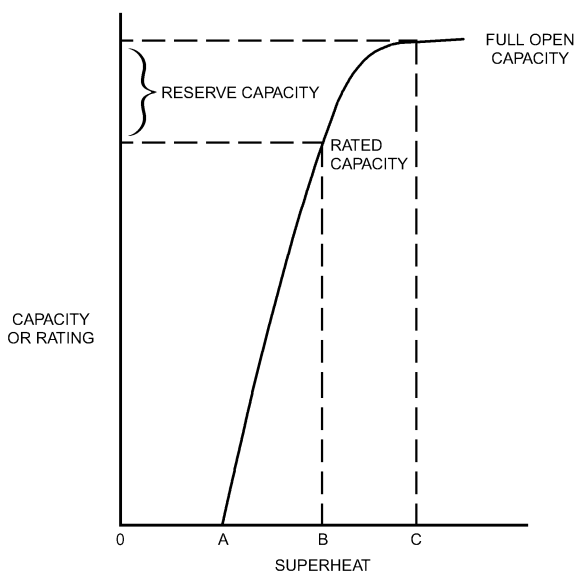


Fig. 12 Typical Gradient Curve for Thermostatic Expansion Valves

These reductions in capacity result from the change in the refrigerant pressure-temperature relationship at lower temperatures. For example, if R-22 is used, the change in saturated pressure between 40 and 45°F is 7.5 psi, whereas between -20 and -15°F the change is 3.0 psi. Although the valve responds to pressure changes, published capacities are based on superheat change. Thus, the valve opening and, consequently, the valve capacity are less for a given superheat change at lower evaporator temperatures.

Pressure drop across the valve port is always the net pressure drop available at the valve, rather than the difference between compressor discharge and compressor suction pressures. Allowances must be made for the following:

- Pressure drop through condenser, receiver, liquid lines, fittings, and liquid line accessories (filters, driers, solenoid valves, etc.).
- Static pressure in a vertical liquid line. If the thermostatic expansion valve is at a higher level than the receiver, there will be a pressure loss in the liquid line because of the static pressure of the liquid.
- Distributor pressure drop.
- Evaporator pressure drop.
- Pressure drop through suction line and accessories, such as evaporator pressure regulators, solenoid valves, accumulators, etc.

Variations in valve capacity related to changes in system conditions are approximately proportional to the following relationship:

$$q = C\sqrt{\rho\Delta p}(h_g - h_f) \quad (1)$$

where

- $q$  = refrigerating effect
- $C$  = thermostatic expansion valve flow constant
- $\rho$  = entering liquid density
- $\Delta p$  = valve pressure difference
- $h_g$  = enthalpy of vapor exiting evaporator
- $h_f$  = enthalpy of liquid entering the thermostatic expansion valve

Thermostatic expansion valve capacity is dependent on vapor-free liquid entering the valve. If flash gas is present in the entering liquid, the valve capacity is reduced substantially for three reasons:

- Refrigerant mass flow passing through the valve is significantly diminished because the two-phase flow has a lower density
- Flow of the compressible vapor fraction chokes at the pressure ratios typically existing across expansion valves and further restricts liquid phase flow rate
- Vapor that passes through the valve provides no refrigerating effect

Flashing of the liquid refrigerant may be caused by pressure drop in the liquid line, the filter-drier, the vertical lift, or a combination of these. If the refrigerant subcooling at the valve inlet is not adequate to prevent flash gas from forming, additional subcooling means must be provided.

### Thermostatic Charges

Each type of thermostatic charge has certain advantages and limitations. The principal types of thermostatic charges and their characteristics are described in the following.

**Gas Charge.** Conventional gas charges are limited liquid charges that use the same refrigerant in the thermostatic element that is used in the refrigeration system. The amount of charge is such that, at a predetermined temperature, all of the liquid has vaporized and any temperature increase above this point results in practically no increase in element pressure. Figure 13 shows the pressure-temperature relationship of the R-22 gas charge in the thermostatic element. Because of the characteristic pressure-limiting feature of its

thermostatic element, the gas-charged valve can provide compressor motor overload protection on some systems by limiting the maximum operating suction pressure (MOP). It also helps prevent floodback (the return of refrigerant liquid to the compressor through the suction line) on starting. Increasing the superheat setting lowers the maximum operating suction pressure; decreasing the superheat setting raises it because the superheat spring and the evaporator pressure act to balance the element pressure through the diaphragm.

Gas-charged valves must be carefully applied to avoid loss of control from the bulb. If either the diaphragm chamber or the capillary tube becomes colder than the bulb, the small amount of charge in the bulb condenses at the coldest point. This results in the valve throttling or closing as detailed in the section on Application.

**Liquid Charge.** Straight liquid charges use the same refrigerant in the thermostatic element that is used in the refrigeration system. The volumes of the bulb, bulb tubing, and diaphragm chamber are so proportioned that the bulb contains some liquid under all temperature conditions. Therefore, the bulb always controls the valve operation, even with a colder diaphragm chamber or bulb tubing.

The characteristics of the straight liquid charge (Figure 14) result in an increase in operating superheat as the evaporator temperature decreases. This usually limits the use of the straight liquid charge to moderately high evaporator temperatures. The valve setting required for a reasonable operating superheat at a low evaporator temperature may cause floodback during cooling from normal ambient temperatures.

**Liquid Cross Charge.** Liquid cross charges, unlike conventional liquid charges, use a liquid in the thermostatic element that is different from the refrigerant in the system. Cross charges have flatter pressure-temperature curves than the system refrigerants with which they are used. Consequently, their superheat characteristics differ considerably from those of straight liquid or gas charges.

Cross charges in the commercial temperature range generally have superheat characteristics that are nearly constant or that deviate only moderately through the evaporator temperature range. This charge, also illustrated in Figure 14, is generally used in the evaporator temperature range of 40 to 0°F or slightly below.

For evaporator temperatures substantially below 0°F, a more extreme cross charge may be used. At high evaporator temperatures, the valve controls at a high superheat. As the evaporator temperature falls to the normal operating range, the operating superheat also falls

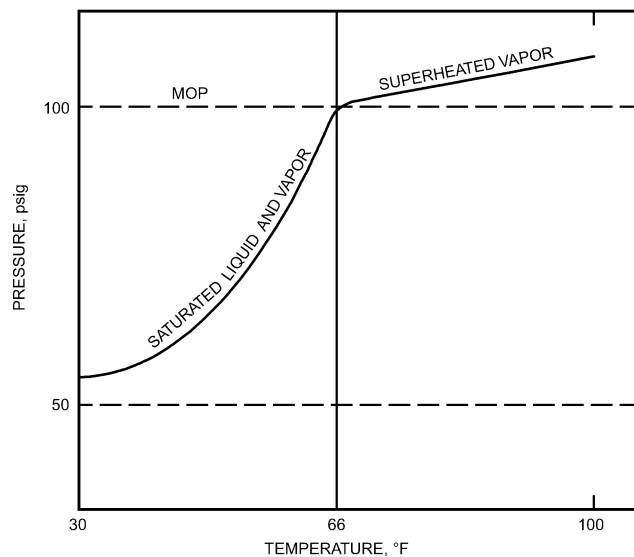


Fig. 13 Pressure-Temperature Relationship of R-22 Gas Charge in Thermostatic Element

to normal. This characteristic prevents floodback on starting, reduces the load on the compressor motor after start-up, and permits a rapid pulldown of suction pressure. To avoid floodback, valves with this type of charge must be set for the optimum operating superheat at the lowest evaporator temperature expected.

**Gas Cross Charge.** Gas cross charges combine the features of the gas charge and the liquid cross charge. They use a limited amount of liquid, thereby providing a maximum operating pressure. The liquid used in the charge is different from the refrigerant in the system and is chosen to provide superheat characteristics similar to those of the liquid cross charges (low temperature). Consequently, they provide both the superheat characteristics of a cross charge and the maximum operating pressure of a gas charge (Figure 14). A commercial (medium-temperature) gas cross charge is possible, but its uses are limited.

**Adsorption Charge.** Typical adsorption charges depend on the property of an adsorbent, such as silica gel or activated carbon, that is used in an element bulb to adsorb and desorb a gas such as carbon dioxide, with accompanying changes in temperature. The amount of adsorption or desorption changes the pressure in the thermostatic element. Because adsorption charges respond primarily to the temperature of the adsorbent material, they are the charges least affected by the ambient temperature surrounding the bulb, bulb tubing, and diaphragm chamber. The comparatively slow response of the adsorbent results in a charge characterized by its stability. Superheat characteristics can be varied by using different charge fluids, adsorbents, and/or charge pressures. The pressure-limiting feature of the gas or gas cross charges is not available with the adsorption element.

**Type of Equalization**

**Internal Equalizer.** When the refrigerant pressure drop through a single-circuit evaporator is equivalent to 2 or 3°F or less, a thermostatic expansion valve that has an internal equalizer may be used. Internal equalization describes valve outlet pressure transmitted through an internal passage to the underside of the diaphragm (see Figure 9).

The pressure drop in many evaporators is greater than the 2 or 3°F equivalent. When a refrigerant distributor is used, the pressure drop across the distributor will cause the pressure at the outlet of the expansion valve to be considerably higher than the pressure at the evaporator outlet. As a result, an internally equalized valve will control at an abnormally high superheat. Under these conditions, the

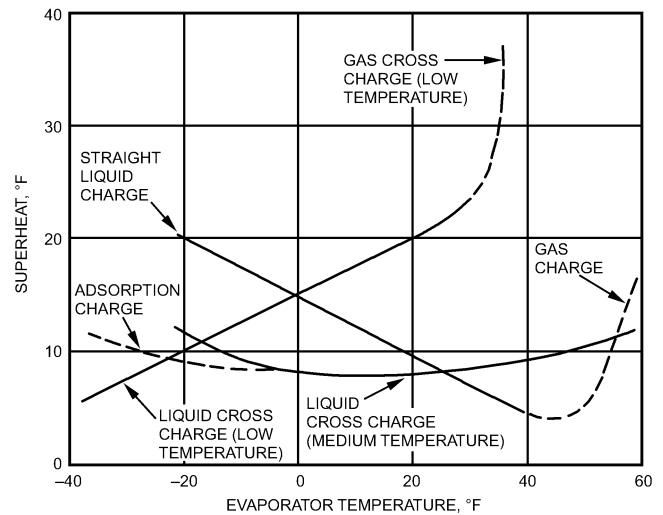


Fig. 14 Typical Superheat Characteristics of Common Thermostatic Charges

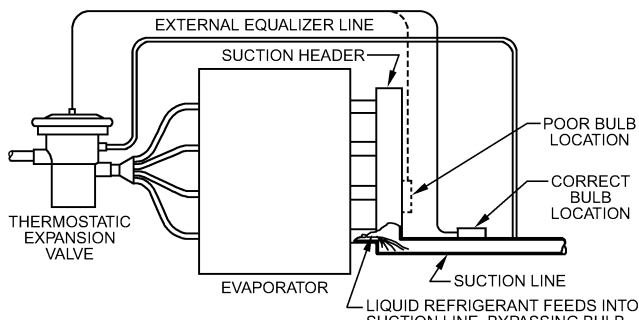
evaporator does not perform efficiently because it is starved for refrigerant. Furthermore, the distributor pressure drop is not constant but varies with refrigerant flow rate and therefore cannot be compensated for by adjusting the superheat setting of the valve.

**External Equalizer.** Because evaporator and/or refrigerant distributor pressure drop causes poor system performance with an internally equalized valve, a valve that has an external equalizer is used. Instead of the internal communicating passage shown in [Figure 9](#), an external connection to the underside of the diaphragm is provided. The external equalizer line is connected either to the suction line, as shown in [Figure 15](#), or into the evaporator at a point downstream from the major pressure drop.

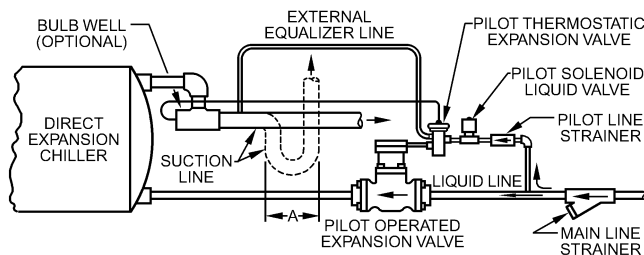
### Alternative Types of Construction

Pilot-operated thermostatic expansion valves are used on large systems in which the required capacity per valve is beyond the range of direct-operated valves. The pilot-operated valve consists of a piston-type pilot-operated regulator, which is used as the main expansion valve, and a low-capacity thermostatic expansion valve, which serves as an external pilot valve. The small pilot thermostatic expansion valve supplies pressure to the piston chamber or, depending on the regulator design, bleeds pressure from the piston chamber in response to a change in the operating superheat. Pilot operation permits the use of a characterized port in the main expansion valve to provide good modulation over a wide load range. Therefore, the pilot-operated valve performs well on refrigerating systems that have some form of compressor capacity reduction, such as cylinder unloading. [Figure 16](#) illustrates such a control valve applied to a large-capacity direct-expansion chiller.

The auxiliary pilot controls should be sized to handle only the pilot circuit flow. For example, in [Figure 16](#) a small solenoid valve in the pilot circuit, installed ahead of the thermostatic expansion valve, converts the pilot-operated valve into a stop valve when the solenoid valve is closed.



**Fig. 15 Bulb Location for Thermostatic Expansion Valve**



**Fig. 16 Pilot-Operated Thermostatic Expansion Valve Controlling Liquid Refrigerant Flow to Direct-Expansion Chiller**

**Equalization Features.** When the compressor stops, a thermostatic expansion valve usually moves to the closed position. This movement sustains the difference in refrigerant pressures in the evaporator and the condenser. Low-starting-torque motors require that these pressures be equalized to reduce the torque needed to restart the compressor. One way to provide pressure equalization is to add, parallel to the main valve port, a small fixed auxiliary passageway, such as a slot or drilled hole in the valve seat or valve pin. This opening permits a limited fluid flow through the control, even when the valve is closed, and allows the system pressures to equalize on the off cycle. The size of such a fixed auxiliary passageway must be limited so its flow capacity is not greater than the smallest flow that must be controlled in normal system operation.

Another, more complex control is available for systems requiring shorter equalizing times than can be achieved with the fixed auxiliary passageway. This control incorporates an auxiliary valve port, which bypasses the primary port and is opened by the element diaphragm as it moves toward and beyond the position at which the primary valve port is closed. The flow capacity of such an auxiliary valve port can be considerably larger than that of the fixed auxiliary passageway, so that pressures can equalize more rapidly.

**Flooded System.** Thermostatic expansion valves are seldom applied to flooded evaporators because superheat is necessary for proper valve control; only a few degrees of suction vapor superheat in a flooded evaporator incurs a substantial loss in capacity. If the bulb is installed downstream from a liquid-to-suction heat exchanger, a thermostatic expansion valve can be made to operate at this point on a higher superheat. Valve control is likely to be poor because of the variable rate of heat exchange as flow rates change (see the section on Application).

Expansion valves with modified thermostatic elements in which electric heat is supplied to the bulb are available. The bulb is inserted in direct contact with refrigerant liquid in a low-side accumulator. The contact of cold refrigerant liquid with the bulb overrides the artificial heat source and throttles the expansion valve. As the liquid falls away from the bulb, the valve feed increases again. Although similar in construction to a thermostatic expansion valve, it is essentially a modulating liquid level control valve.

**Desuperheating Valves.** Thermostatic expansion valves with special thermostatic charges are used to reduce gas temperatures (superheat) on various air conditioning and refrigeration systems. Suction gas in a single-stage system can be desuperheated by injecting liquid directly into the suction line. This cooling may be required with or without discharge gas bypass used for compressor capacity control. The line upstream of the valve bulb must be long enough so the injected liquid refrigerant can mix adequately with the gas being desuperheated. On compound compression systems, a specially selected expansion valve may be used to inject liquid directly into the interstage line upstream of the valve bulb to provide intercooling.

### Application

**Hunting** is alternate overfeeding and starving of the refrigerant feed to the evaporator. It produces sustained cyclic changes in the pressure and temperature of the refrigerant gas leaving the evaporator. Extreme hunting reduces the capacity of the refrigeration system because the mean evaporator pressure and temperature are lowered and the compressor capacity is reduced. If overfeeding of the expansion valve causes intermittent flooding of liquid into the suction line, the compressor may be damaged.

Although hunting is commonly attributed to the thermostatic expansion valve, it is seldom solely responsible. One reason for hunting is that all evaporators have a time lag. When the bulb signals for a change in refrigerant flow, the refrigerant must traverse the entire evaporator before a new signal reaches the bulb. This lag or time lapse may cause continuous overshooting of the valve both opening and closing. In addition, the thermostatic element, because

of its mass, has a time lag that may be in phase with the evaporator lag and amplify the original overshooting.

It is possible to alter the response rate of the thermostatic element by either using thermal ballast or changing the mass or heat capacity of the bulb, thereby damping or even eliminating the hunting. A change in valve gradient may produce the same result.

Slug flow or percolation in the evaporator can also cause hunting. Under these conditions, liquid refrigerant moves in waves, called slugs, that fill a portion of the evaporator tube and erupt into the suction line. These unevaporated slugs chill the bulb and temporarily reduce the feed of the valve, resulting in intermittent starving of the evaporator.

On multiple-circuit evaporators, a lightly loaded or overfed circuit will also flood into the suction line, chill the bulb, and throttle the valve. Again, the effect is intermittent; when the valve feed is reduced, the flooding ceases and the valve reopens.

Hunting can be minimized or avoided by the following actions:

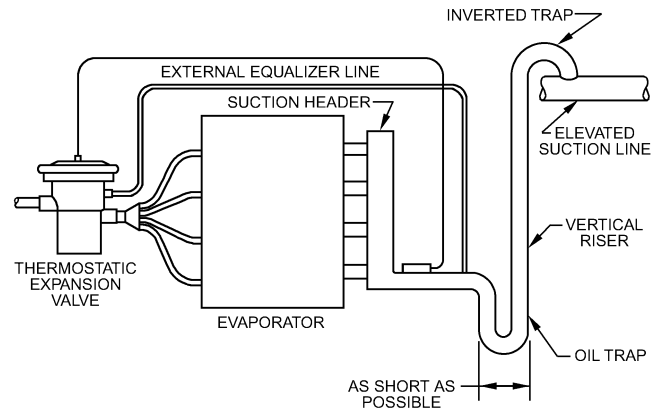
- Select the proper valve size from the valve capacity ratings rather than nominal valve capacity; oversized valves aggravate hunting.
- Change the valve adjustment. A lower superheat setting usually (but not always) increases hunting.
- Select the correct thermostatic element charge. Cross-charged elements are less susceptible to hunting.
- Design the evaporator section for even refrigerant and air flow. Uniform heat transfer from the evaporator is only possible if refrigerant is distributed by a properly selected and applied refrigerant distributor and air distribution is controlled by a properly designed housing. (Air-cooling and dehumidifying coils, including refrigerant distributors, are detailed in [Chapter 21 of the ASHRAE Handbook—HVAC Systems and Equipment.](#))
- Size and arrange suction piping correctly.
- Locate and apply the bulb correctly.
- Select the best location for the external equalizer line connection.

**Bulb Location.** Most installation requirements are met by strapping the bulb to the suction line to obtain good thermal contact between them. Normally, the bulb is attached to a horizontal line upstream of the external equalizer connection (if used) at a 3 or 9 o'clock position as close to the evaporator as possible. The bulb is not normally placed near or after suction line traps, but some designers test and prove locations that differ from these recommendations. A good moisture-resistant insulation over the bulb and suction line diminishes the adverse effect of varying ambient temperatures at the bulb location.

Occasionally, the bulb of the thermostatic expansion valve is installed downstream from a liquid-suction heat exchanger to compensate for a capacity shortage due to an undersized evaporator. Although this procedure seems to be a simple method of obtaining maximum evaporator capacity, installing the bulb downstream of the heat exchanger is undesirable from a control standpoint. As the valve modulates, the liquid flow rate through the heat exchanger changes, causing the rate of heat transfer to the suction vapor to change. An exaggerated valve response follows, resulting in hunting. It may be possible to find a bulb location downstream from the heat exchanger that reduces the hunt considerably. However, the danger of floodback to the compressor normally overshadows the need to attempt this method.

Certain installations require increased bulb sensitivity as a protection against floodback. The bulb, if located properly in a well in the suction line, has a rapid response feature because of its intimate contact with the refrigerant stream. The bulb sensitivity can be increased by using a bulb smaller than is normally supplied. However, the use of the smaller bulb is limited to gas-charged valves. Good piping practice also affects expansion valve performance.

[Figure 17](#) illustrates the proper piping arrangement when the suction line runs above the evaporator. A lubricant trap that is as short as possible is located downstream from the bulb. The vertical



**Fig. 17 Bulb Location When Suction Main Is Above Evaporator**

riser(s) must be sized to produce a refrigerant velocity that ensures continuous return of lubricant to the compressor. The terminal end of the riser(s) enters the horizontal run at the top of the suction line; this avoids both interference from the overfeeding of any other expansion valve or any drainback during the off cycle.

If circulated with lubricant-miscible refrigerant, a heavy concentration of lubricant elevates boiling temperature of the refrigerant. The response of the thermostatic charge of the expansion valve is related to the saturation pressure and the temperature of pure refrigerant. In an operating system, the false pressure-temperature signals of lubricant-rich refrigerants cause both floodback or operating superheats considerably lower than indicated and quite often cause erratic valve operation. To keep the lubricant concentration at an acceptable level, either the lubricant pumping rate must be reduced or an effective lubricant separator must be used.

The **external equalizer** line is ordinarily connected at the evaporator outlet, as shown in [Figure 17](#). It may also be connected at the evaporator inlet or at any other point in the evaporator downstream of the major pressure drop. On evaporators with long refrigerant circuits that have inherent lag, hunting may be minimized by changing the connection point of the external equalizer line.

In application, the various parts of the valve's thermostatic element are simultaneously exposed to different thermal influences from the surrounding ambient air and the refrigerant system. In some situations the cold refrigerant exiting the valve dominates and cools the thermostatic element to below the bulb temperature. When this occurs with a gas-charged or gas cross-charged valve, the charge condenses at the coldest point in the element and control of refrigerant feed moves from the bulb to the thermostatic element. The pressure applied to the top of the diaphragm diminishes to saturation pressure at the cold point. Extreme starving of the evaporator, progressing to complete cessation of refrigerant flow, is characteristic of this occurrence. For this reason, gas-charged or gas cross-charged valves should be applied only to multicircuited evaporators that employ refrigerant distributors. The distributor typically provides sufficient pressure drop to maintain a saturation temperature at the valve outlet well above the temperature at the bulb location.

Internally equalized gas-charged or gas cross-charged valves should only be considered in very carefully selected applications where the risk of loss of control can be minimized. Some gas cross-charge formulations may be slightly less susceptible to the described loss of control than are straight gas charges, but they are far from being immune. Gas-charged and gas cross-charged valves with specially constructed thermostatic power elements that positively isolate the charge fluids in the temperature sensing element (bulb) have been applied in situations where there was high risk of

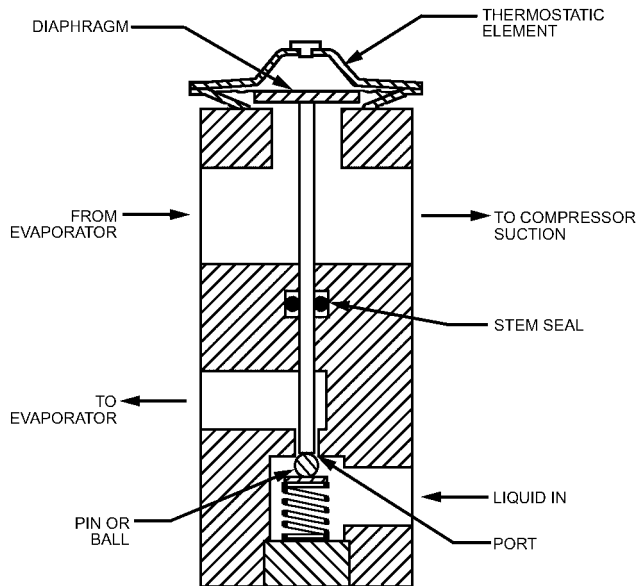


Fig. 18 Typical Block Valve

control loss, but the pressure-limiting feature of a gas-charged valve was required.

Gas-charged bulbless valves, frequently called block valves (Figure 18), are practically immune to loss of control because the thermostatic element is located at the evaporator outlet. The valve is constructed so that the temperature-sensing function of the remote bulb is integrated into the thermostatic element by purposely confining all of the charge fluid to this chamber.

Liquid, liquid cross-charged, and adsorption-charged valves are not susceptible to the same type of loss of control that gas-charged or gas cross-charged valves are. However, exposure to extreme ambient temperature environments will cause shifting of operating superheats. The degree of superheat shift depends on the severity of the thermal exposure. High ambient temperatures surrounding thermally sensitive parts of the valve will typically lower operating superheats and vice versa. Gas-charged and gas cross-charged valves, including bulbless or block valves, respond to high ambient exposure similarly but will starve the evaporator when exposed to ambient temperatures below evaporator outlet refrigerant temperatures.

### ELECTRIC EXPANSION VALVES

The application of an electric expansion valve requires a valve, a controller, and control sensors. The control sensors may include pressure transducers, thermistors, RTDs, or other pressure and temperature control sensors. See [Chapter 14, Measurement and Instruments in the ASHRAE Handbook—Fundamentals](#) for a discussion of instrumentation. Specific types should be discussed with the electric valve and electronic controller manufacturers to ensure compatibility of all components.

Electric valves typically have four basic types of actuation:

- Heat-motor operated
- Magnetically modulated
- Pulse-width-modulated (on-off type)
- Step-motor-driven

**Heat-motor valves** may be either of two types. In one type, one or more bimetallic elements are heated electrically, causing them to deflect. The bimetallic elements are linked mechanically to a valve pin or poppet; as the bimetallic element deflects, the valve pin or

poppet follows the element movement. In the second type, a volatile fluid is contained within an electrically heated chamber so that the regulated temperature (and pressure) is controlled by electrical power input to the heater. The regulated pressure acts on a diaphragm or bellows, which is balanced against atmospheric air pressure or refrigerant pressure. The diaphragm is linked to a pin or poppet.

A **magnetically modulated** (analog) valve functions by modulation of an electromagnet; a solenoid armature compresses a spring progressively as a function of magnetic force. The modulating armature may be connected to a valve pin or poppet directly or may be used as the pilot element to operate a much larger valve. When the modulating armature operates a pin or poppet directly, the valve may be of a pressure-balanced port design so that pressure differential has little or no influence on valve opening.

The **pulse-width-modulated valve** is an on-off solenoid valve with special features that allow it to function as an expansion valve through a life of millions of cycles. Although the valve is either fully opened or closed, it operates as a variable metering device by pulsing the valve open. For example, if 50% flow is needed, the valve will be open 50% of the time and closed 50% of the time. The duration of each opening, or pulse, is regulated by the electronics.

A **step motor** is a multiphase motor designed to rotate in discrete fractions of a revolution, based on the number of signals or “steps” sent by the controller. The controller tracks the number of steps and can offer fine control of the valve position with almost absolute repeatability. Step motors are used in instrument drives, plotters, and other applications where accurate positioning is required. When used to drive expansion valves, a lead screw changes the rotary motion of the rotor to a linear motion suitable for moving a valve pin or poppet. The lead screw may be driven directly from the rotor, or a reduction gearbox may be placed between the motor and lead screw. The motor may be hermetically sealed within the refrigerant environment, or the motor and gearbox can operate outside the refrigerant system with an appropriate stem seal.

Electric expansion valves may be controlled by either digital or analog electronic circuits. Electronic control gives additional flexibility over traditional mechanical valves to consider control schemes that would otherwise be impossible, including stopped or full flow when required.

The electric expansion valve, with properly designed electronic controllers and control sensors, offers a refrigerant flow control means that is not refrigerant specific, has a very wide load range, is able to be set remotely, and can respond to a variety of input parameters.

### REGULATING AND THROTTLING VALVES

Regulating and throttling valves are used in refrigeration systems to perform a variety of functions. Valves that respond to and control their own inlet pressure are called **upstream pressure regulators**. This type of regulator, when located in an evaporator vapor outlet line, responds to evaporator outlet pressure and is commonly called an **evaporator pressure regulator**. A special three-way version of an upstream pressure regulator is designed specifically for air-cooled condenser pressure regulation during cold-weather operation. Valves that respond to and control their own outlet pressure are called **downstream pressure regulators**. Downstream pressure regulators located in a compressor suction line regulate compressor suction pressure and may also be called suction pressure regulators, crankcase pressure regulators or holdback valves. A downstream pressure regulator located at an evaporator inlet to feed liquid refrigerant into the evaporator at a constant evaporator pressure is known as a constant pressure expansion valve or automatic expansion valve.

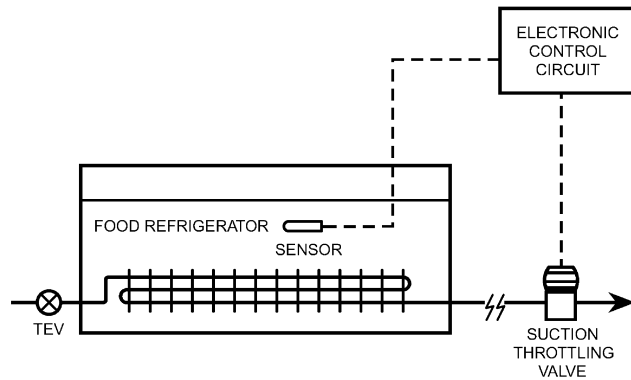


Fig. 19 Electronically Controlled, Electrically Operated Suction-Throttling Regulator

A third category of pressure regulator, a **differential pressure regulator**, responds to and controls the difference between its own inlet and outlet pressures.

**Electronically controlled, electrically operated suction throttling valves** have been developed to control temperature in food merchandising refrigerators and other refrigerated spaces (Figure 19). This type of valve regulates evaporator pressure, although it responds only to temperature in the space or load, rather than pressure in the evaporator or suction line. The system consists of a temperature sensor, an electronic control circuit that has been programmed by the manufacturer with a control strategy or algorithm, and an electrically driven suction throttling valve. The set point may be set or changed on site or at a remote location through communication software. The valve responds to the difference between set-point temperature and the sensed temperature in the space or load. A sensed temperature above the set point drives the valve further open, thereby reducing evaporator pressure and saturation temperature; a sensed temperature below set point modulates the valve in the closing direction, which increases evaporator pressure. During defrost, the control circuit usually closes the valve. Additional information on the drive and sensing mechanisms used with this valve type is given in the sections on Electric Expansion Valves and on Control Sensors.

Electronically controlled throttling valves may also be employed in a variety of other applications, such as discharge gas bypass capacity reduction, compressor suction throttling, condenser pressure regulation, gas defrost systems, and heat reclaim schemes.

### EVAPORATOR-PRESSURE-REGULATING VALVES

The evaporator pressure regulator is a regulating valve designed to control its own inlet pressure. Typically installed in the suction line exiting an evaporator, it regulates that evaporator's outlet pressure, which is the regulator's upstream or inlet pressure. For this reason evaporator pressure regulators are referred to as upstream pressure regulators. They are most frequently used to prevent evaporator pressure (and saturation temperature) from dropping below a desired minimum. As declining regulator inlet pressure approaches the regulator set point, the valve throttles, thereby maintaining the desired minimum evaporator pressure (and temperature). Evaporator pressure regulators are often employed to balance evaporator capacity with varying load conditions and to protect against freezing at low loads, such as in water chillers.

The work required to drive pilot-operated valves is most commonly produced by harnessing the pressure loss caused by flow through the valve. Direct-operated regulating valves are powered by relatively large changes in the controlled variable (in this case, inlet

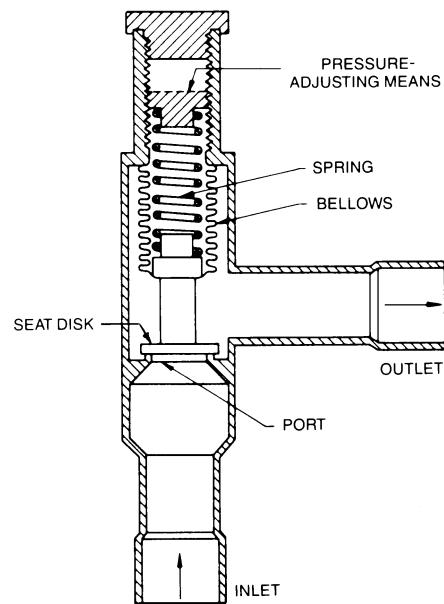


Fig. 20 Direct-Operated Evaporator Pressure Regulator

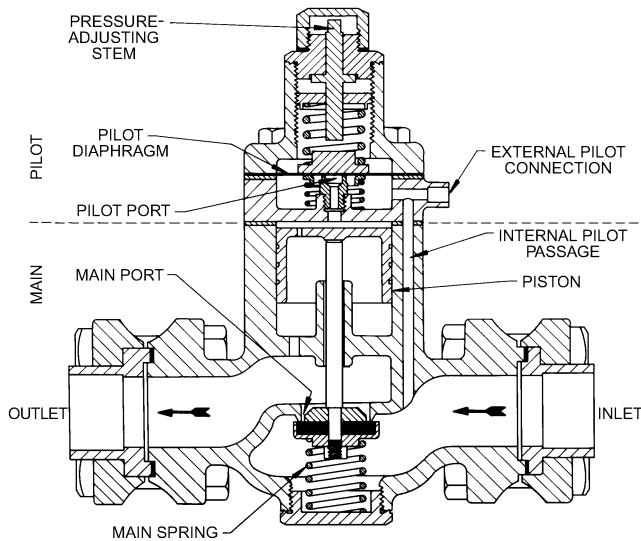
pressure). Pilot- and direct-operated evaporator pressure regulators may be classified as self-powered. Evaporator pressure regulators are sometimes driven by a high-pressure refrigerant liquid or gas flowing from the system's high-pressure side, as well as electrically. These types are usually considered to be externally powered.

### Operation

**Direct-operated evaporator-pressure-regulating valves** are relatively simple devices, as shown in Figure 20. The inlet pressure acts on the bottom of the seat disk and opposes the spring. The outlet pressure acts on the bottom of the bellows and the top of the seat disk. Because the effective areas of the bellows and the port are equal, these two forces cancel each other, and the valve responds to inlet pressure only. When the inlet pressure rises above the equivalent pressure exerted by the spring force, the valve begins to open. When the inlet pressure falls, the spring moves the valve in the closing direction. In operation, the valve assumes an intermediate throttling position that balances the refrigerant flow rate with evaporator load.

Because both spring and bellows must be compressed through the entire opening valve stroke, a significant change in inlet pressure is required to open the valve to its rated capacity. Inlet pressure changes of 5 to 10 psi or more, depending on design, are typically required to move direct-operated evaporator pressure regulators from closed position to their rated flow capacity. Therefore these valves have relatively high gradients and the system may experience significant changes in regulated evaporator pressure when large load changes occur.

**Pilot-operated evaporator-pressure-regulating valves** are either self-powered or high-pressure-driven. The self-powered regulator (Figure 21) starts to open when the inlet pressure approaches the equivalent pressure setting of the diaphragm spring. The diaphragm lifts to allow inlet pressure to flow through the pilot port, which increases the pressure above the piston. This increase moves the piston down, causing the main valve to open. Flow through the opening valve relieves evaporator pressure into the suction line. As the evaporator pressure diminishes, the diaphragm throttles flow through the pilot port, a bleed hole in the piston relieves the pressure above the piston to the low-pressure outlet side of the main valve, and the main spring moves the valve in the closing direction. Balanced flow rates through the pilot port and piston bleed hole



**Fig. 21 Pilot-Operated Evaporator Pressure Regulator (Self-Powered)**

establish a stable piston pressure that balances against the main spring. The main valve assumes an intermediate throttling position that permits the refrigerant flow rate required to satisfy the evaporator load. Pilot-operated regulators have relatively low gradients and are capable of precise pressure regulation in evaporators that experience large load changes. Typically, a pressure loss of up to 2 psi is required to move the valve to its full open position.

Suction stop service can be provided with this style regulator by adding a pilot solenoid valve in the equalizer flow passage that will prevent inlet pressure from reaching the underside of the pressure pilot diaphragm regardless of inlet pressure. Suction stop service is often required to facilitate and control evaporator defrost.

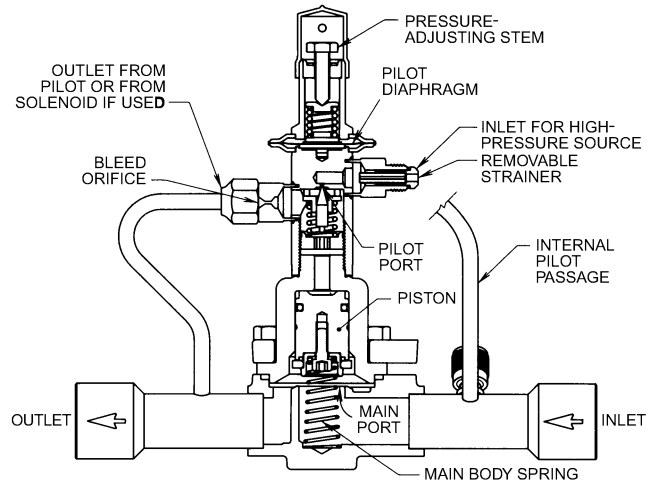
**High-pressure-driven pilot-operated regulating valves** are of a normally open design and require high-pressure liquid or gas to provide a closing force. One advantage of this design over self-powered regulators is that it does not require any suction pressure drop across the valve or large inlet pressure change to operate. When the valve inlet pressure increases above set point (Figure 22), the diaphragm moves up against the spring, permitting the pilot valve pin spring to move the pilot valve pin, pin carrier, and push rods (not shown) upward toward closing the pilot valve port. The gas or liquid from the high-pressure side of the system is throttled by the pilot valve and pressure in the top of the piston chamber bleeds to the downstream side of the valve through a bleed orifice. As pressure on top of the piston diminishes, the main body spring makes the valve more open.

As inlet pressure diminishes, increased flow of high-pressure liquid or gas through the pilot valve drives the piston down toward a closed position.

A solenoid valve may be used to drive the piston to closed position for suction stop service, either by closing the bleed orifice or by supplying high pressure directly to the top of the piston chamber. In the latter arrangement it should be noted that a continuous, but very small, flow of liquid or gas from the system high side will be discharged into the suction line downstream of the regulator while the valve is closed. In some applications this bleed may enhance compressor cooling and lubricant return.

### Selection

Selection of evaporator-pressure-regulating valves is based on the flow capacity required to satisfy the load imposed on the evaporator being regulated and the pressure drop available across the



**Fig. 22 Pilot-Operated Evaporator Pressure Regulator (High-Pressure-Driven)**

regulator. For example, if an evaporator is to be regulated to a pressure of 30 psig and the regulator is discharging into a suction line that normally operates or is maintained at 20 psig, the regulator should be selected to satisfy the evaporator load at a 10 psi pressure loss across the valve. To select direct-operated regulators, consider the high gradient of this design; make certain that the variation of inlet pressure that will occur with load changes is acceptable for the application. For example, a direct-operated regulator set at high-load operating conditions to protect against chiller freeze-up may allow the evaporator pressure to drop into the freeze-up danger zone at low loads because of the large reduction in inlet pressure necessary to throttle the valve to near-closed stroke. Externally powered regulators should be selected to satisfy the flow requirements imposed by the evaporator load at pressure drops compatible with the application.

Grossly oversized regulating valves are very susceptible to unstable operation, which may in turn upset the stability of other controls in the system and significantly degrade system performance.

### Application

Evaporator pressure regulators are used on finned-coil air-cooling evaporators to control frosting or prevent excessive dehumidification. Evaporator pressure regulators are also used on water and brine chillers to protect against freezing under low-load conditions.

When multiple evaporators are connected to a common suction line, as shown in Figure 23, evaporator pressure regulators may be installed to control evaporator pressure in each individual unit or in a group of units operating at the same pressure. The regulators maintain the desired saturation temperature in the evaporators serving the high- and medium-temperature loads; evaporators serving low-temperature loads may be directly connected to the suction main. In such systems, the compressor(s) are loaded, unloaded, and cycled to maintain the suction main pressure as the combined evaporator loads vary.

The pilot-operated self-powered evaporator pressure regulator, with internal pilot passage, receives its source of pressure to both power the valve and sense the controlled pressure at the regulator inlet connection. A regulator with an external pilot connection permits a choice of remote pressure source for both controlled pressure sensing and driving the valve. The external pilot connection can also facilitate the use of remote pressure and solenoid pilot valves. Figure 22 shows a pilot solenoid valve installed in the external pilot

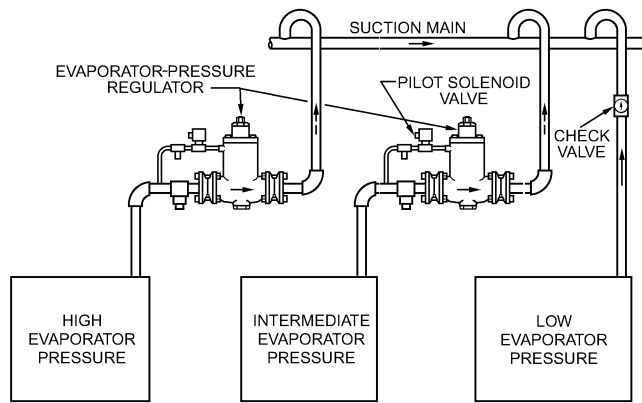


Fig. 23 Evaporator Pressure Regulators in Multiple System

line. This arrangement allows the regulator to function as a suction stop valve as well as an evaporator pressure regulator. The suction stop feature is particularly useful on a flooded evaporator to prevent pumping all of the refrigerant out of the evaporator when the load is satisfied and the evaporator is deactivated. The stop feature is also effective during evaporator defrost cycles, especially with gas defrost systems. In situations where the regulator inlet pressure is unstable to the point of upsetting regulator performance, the external pilot connection may be used to facilitate the use of volume chambers and other non-flow-restricting dampening means to smooth the pilot pressure source before it enters the regulator pilot connection.

A remote pressure pilot installed in the external pilot line can be located to allow manual adjustment of the pressure setting when the main regulator must be installed in an inaccessible location.

Multiple pilots, including temperature actuated pilots, pressure pilots, and solenoid pilot stop valves, may be connected in a variety of parallel-series arrangements to the external pilot connection, thereby allowing the main valve to function in different modes and pressure settings, depending on which pilot is selected to control. The controlling pilot is then selected by activating the appropriate solenoid stop valve. Pressure pilots may also be adapted to accept connection to pneumatic control systems, allowing automatic resetting of the pressure pilot as part of a much more comprehensive control strategy.

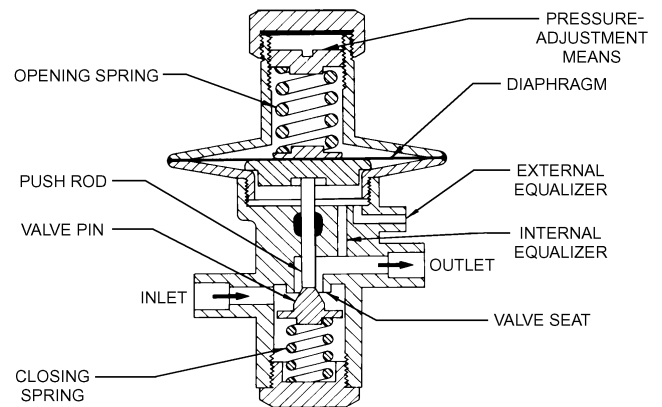
Although evaporator pressure regulation is the most common use of upstream pressure regulators, they are also employed in a variety of other refrigeration system applications. Upstream pressure regulators may be adapted for internal pressure relief, air-cooled condenser pressure regulation during low ambient operation, and liquid receiver pressure regulation.

### CONSTANT-PRESSURE EXPANSION VALVES

The constant-pressure expansion valve is a downstream pressure regulator that is positioned to respond to evaporator pressure changes and meter the mass flow of liquid refrigerant entering the evaporator to maintain a constant evaporator pressure.

#### Operation

Figure 24 shows a cross section of a typical constant-pressure expansion valve. The valve has both an adjustable opening spring, which exerts its force on top of the diaphragm in an opening direction, and a spring beneath the diaphragm, which exerts its force in a closing direction. Evaporator pressure is admitted beneath the diaphragm, through either the internal or external equalizer passage, and the combined forces of the evaporator pressure and the closing spring act to counterbalance the adjustable opening spring force.



Valve is used with either internal or external equalizer, but not with both.

Fig. 24 Constant-Pressure Expansion Valve

During normal system operation, a small increase in the evaporator pressure pushes the diaphragm up against the adjustable opening spring, allowing the closing spring to move the pin in a closing direction. This restricts the refrigerant flow and limits the evaporator pressure. When the evaporator pressure drops below the valve setting, due to a decrease in load, the opening spring moves the valve pin in an opening direction. As a result, the refrigerant flow increases and raises the evaporator pressure, bringing the three primary forces in the valve back into balance.

Because constant-pressure expansion valves respond to evaporator load changes inversely, their primary application is in systems that have nearly constant evaporator loading.

#### Selection

The constant-pressure expansion valve should be selected to provide the required liquid refrigerant flow capacity at the expected pressure drop across the valve and should have an adjustable pressure range that includes the required design evaporator (valve outlet) pressure. The system designer should decide whether off-cycle pressure equalization is required.

#### Application

Constant pressure expansion valves overfeed the evaporator as the load diminishes and underfeed as the load increases. Their primary function is to balance liquid flow rate with compressor capacity at constant evaporator pressure/temperature as loading varies, protecting against product freezing at low loads and compressor motor overload when evaporator loading increases. Because the valve responds inversely to evaporator load variations, other means to protect the compressor against liquid floodback at low loads and overheating at high loads must be provided in systems that experience significant load variation. Such means may include suction line accumulators, enhanced compressor cooling or liquid injection devices.

Constant-pressure expansion valves are best suited to simple single compressor/single evaporator systems when constant evaporator temperature is important and significant load variation doesn't occur. They are commonly used in drink dispensers, food dispensers, cold water drinking fountains, ice cream freezers, and self-contained room air conditioners. They are typically direct-operated devices; however, they may be pilot operated for applications requiring very large capacity. They are also used to regulate hot gas in discharge bypass capacity reduction arrangements as described in the section on Discharge Bypass Valves.

Constant-pressure expansion valves close in response to the abrupt increase in evaporator pressure when the compressor cycles

off, preventing flow during the off-cycle. A small, fixed auxiliary passageway, described in the section on Thermostatic Expansion Valves, can also be built into constant-pressure expansion valves to provide off-cycle pressure equalization for use with low-starting-torque compressor motors.

### SUCTION-PRESSURE-REGULATING VALVES

The suction pressure regulator is a downstream pressure regulator positioned in a compressor suction line to respond to and limit compressor suction pressure. Typically, they are used to prevent compressor motor overload due to high suction pressure related to warm start-up, defrost termination, and intermittent high evaporator loading.

#### Operation

**Direct-acting suction pressure regulators** respond to their own outlet or downstream pressure. They are relatively simple devices, as illustrated in [Figure 25](#). The valve outlet pressure acts on the bottom of the disk and exerts a closing force, which is opposed by the adjustable spring force. The inlet pressure acts on the underside of the bellows and the top of the seat disk. Because the effective areas of the bellows and port are equal, these two forces cancel each other and the valve responds to outlet pressure only. When the outlet pressure falls below the equivalent force exerted by the spring, the seat disk moves in an opening direction to maintain outlet pressure. If the outlet pressure rises, the seat disk moves in a closing direction and throttles the refrigerant flow to limit the downstream pressure. The proper pressure setting for a specific system is one that is low enough to protect the compressor from an overload condition without unnecessarily compromising system capacity. Because both spring and bellows must be compressed through the entire closing valve stroke, a significant change in outlet pressure is required to close the valve to its minimum capacity. Outlet pressure changes of 5 to 10 psi or more, depending on design, are typically required to move direct-operated downstream pressure regulators from open

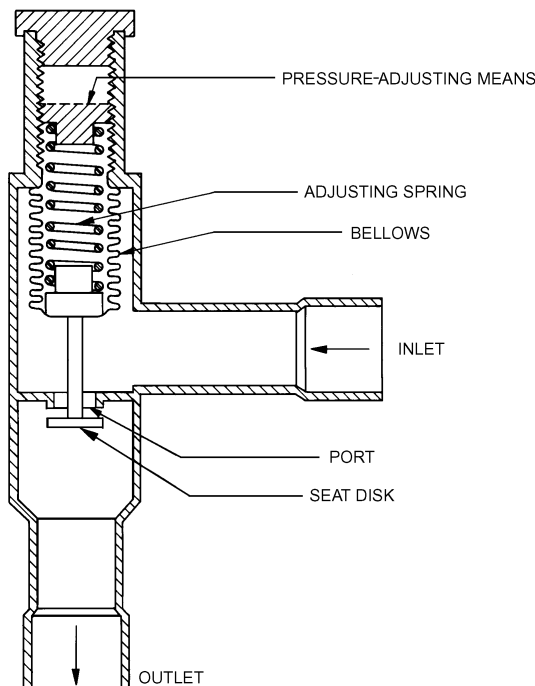


Fig. 25 Direct-Acting Suction Pressure Regulator

position to near closed position. Therefore these valves have relatively high gradients and the system may experience significant changes in regulated suction pressure when large changes in load occur.

**Pilot-operated suction pressure regulators** are available for larger systems and applications requiring more precise pressure regulation over wide load and inlet pressure variations. Their design is significantly more complex, due to pilot operation. The method of operation is similar to that described in the section describing pilot-operated evaporator pressure regulators. However, in downstream pressure regulators the pilot is reverse-acting and functions similarly to the constant-pressure expansion valve. Suction stop service can also be provided with this type of regulator.

#### Selection

The suction pressure regulator should be selected to provide the required flow capacity at a low pressure loss to minimize system capacity penalty. However, care should be taken to avoid oversizing, which can lead to unstable regulator operation. The significant change in outlet pressure required to stroke direct-operated regulators should also be considered in the selection process.

#### Application

Suction-pressure-regulating valves are primarily used to prevent compressor motor overload caused by excessive suction pressure related to warm evaporator start-up, defrost termination, or intermittent high-load operation. These regulating valves are typically designed to operate at normal refrigeration system low-side pressures and temperatures. However, similar type downstream pressure regulators may be modified to include suitable seat materials and high-gradient springs for application in system high-side pressure and temperature conditions. For example, they may be used in a variety of schemes to maintain necessary operating pressures in air-cooled condensers during cold-weather operation. Additionally, such modified regulators are used to bypass compressor discharge gas in refrigeration system capacity reduction schemes, as mentioned in the application sections in the Constant-Pressure Expansion Valves and Discharge Bypass Valves sections.

### CONDENSER-PRESSURE-REGULATING VALVES

Various pressure-regulating valves are used to maintain sufficient pressure in air-cooled condensers operating during the winter. Both single- and two-valve arrangements have been used for this purpose. See [Chapter 2, System Practices for Halocarbon Refrigerants](#) in this volume and [Chapter 35, Condensers of the ASHRAE Handbook—HVAC Systems and Equipment](#) for more information.

#### Operation

The first valve in the two-valve arrangement is typically an upstream pressure regulator that is constructed and operates similarly to the evaporator-pressure-regulating valves shown in [Figures 20 and 21](#). It may have special features that make it suitable for high-pressure and high-temperature operating conditions. This control is installed at either the condenser inlet or outlet. It throttles when the condenser outlet or compressor discharge pressure falls as a result of cold-weather operating conditions.

The second valve in the two-valve arrangement is installed in a condenser bypass line. It may be a downstream pressure regulator similar to the one shown in [Figure 25](#) or a differential pressure regulator as shown in [Figure 26](#). As the first valve throttles in response to falling compressor discharge or condenser outlet pressure, the second valve opens, and allows hot gas to bypass the condenser to mix with and warm the cold liquid entering the receiver, thereby maintaining adequate high-side saturation pressure.

Special-purpose three-way pressure-regulating valves similar to that shown in [Figure 27](#) are also used for condenser pressure regulation. The valve in [Figure 27](#) is a direct-acting upstream pressure regulator with a second inlet that performs the hot-gas bypass function, eliminating the need for the second valve in the two-valve system. The three-way valve simultaneously throttles liquid flow from the condenser and bypasses hot compressor discharge gas to the valve outlet, where it mixes with and heats the liquid entering the receiver and thus maintains adequate pressure in the liquid line.

The lower side of a metal diaphragm is exposed to system high-side pressure, and the upper side is exposed to a noncondensable gas charge (usually dry nitrogen). A pushrod connects the diaphragm to the poppet, which seats on either the upper or lower port and throttles either the discharge gas or the liquid from the condenser, respectively.

During system start-up in extremely cold weather, the poppet may be tight against the lower seat, stopping all liquid flow from the condenser and bypassing discharge gas into the receiver until adequate system high-side pressure is generated. During stable operation in cold weather, the poppet modulates at an intermediate position, with liquid flow from the condensing coil mixing with compressor discharge gas within the valve outlet and flowing to the receiver. With higher condensing pressure during warm weather, the poppet seats tightly against the upper port, allowing free flow of

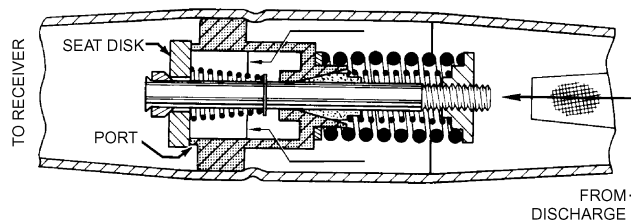


Fig. 26 Condenser Bypass Valve

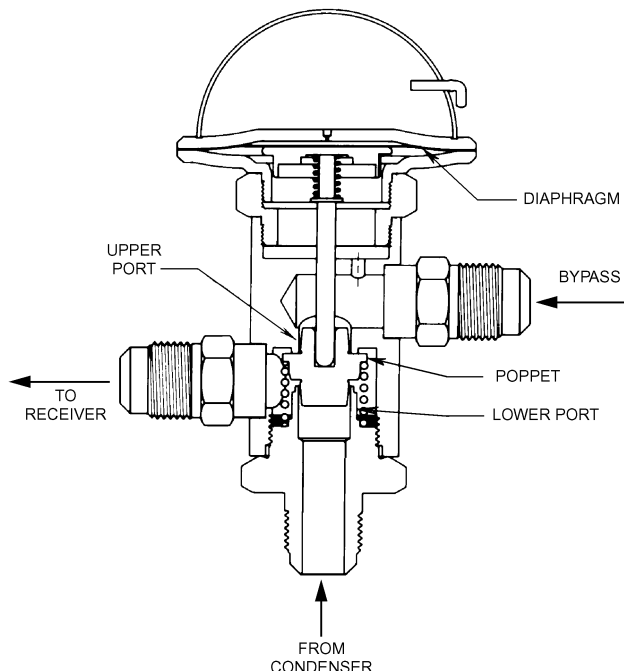


Fig. 27 Three-Way Condenser-Pressure-Regulating Valve

liquid from the condenser to the receiver and preventing compressor discharge gas from bypassing the condenser.

The three-way condenser-pressure-regulating valve set point is usually not field-adjustable. The pressure setting is established by the pressure of the gas charge placed in the dome above the diaphragm during manufacture.

### Application

Systems using pressure regulators for air-cooled condenser pressure control during cold-weather operation require careful system design. In this type of system, condenser pressure is maintained by partially filling the condenser with liquid refrigerant, reducing the effective condensing surface available. The condenser is flooded with liquid refrigerant to the point of balancing condenser capacity at low ambient with condenser loading. The system must have adequate refrigerant charge and receiver capacity to maintain a liquid seal at the expansion valve inlet while allowing sufficient liquid for head pressure control to accumulate in the condenser. If the system cycles off or otherwise becomes idle during cold weather, the receiver must be kept warm during the off time so that adequate liquid pressure is available at start-up. In some systems it may be necessary to provide receiver heaters and insulation to ensure start-up capability. A check valve at the receiver inlet may be advisable in some situations.

Because these systems necessarily contain abnormally large refrigerant charges, careful consideration must be given to controlling refrigerant migration during system idle times under adverse ambient-temperature conditions.

### DISCHARGE BYPASS VALVES

The discharge bypass valve (or hot-gas bypass valve) is a downstream pressure regulator located between the compressor discharge line and the system low-pressure side, and responds to evaporator pressure changes to maintain a desired minimum evaporator pressure. Typically, they are employed to limit the minimum evaporator pressure during periods of reduced loads to prevent coil icing or to avoid operating the compressor at a lower suction pressure than recommended. See [Chapter 2. System Practices for Halocarbon Refrigerants](#) in this volume for more information.

### Operation

A typical mechanical discharge bypass valve would have the same basic configuration as the constant-pressure expansion valve shown in [Figure 24](#). The construction materials for the discharge bypass valve would employ suitable seat materials and higher-gradient springs for application in system high-side pressure and temperature conditions.

The equivalent pressure from the adjustable spring is balanced across the diaphragm against system evaporator pressure. When the evaporator pressure falls below the valve setting, the spring strokes the seat disk open.

### Selection

Discharge bypass valves are rated on the basis of allowable evaporator temperature change from closed position to rated opening. This is 6°F for most air-conditioning applications, although capacity multipliers for other changes are available to make the appropriate valve selection. Because several basic system factors will be involved in the appropriate selection procedure, it is important to know the type of refrigerant, minimum allowable evaporating temperature at the reduced load condition, compressor capacity at minimum allowable evaporating temperature, minimum evaporator load at which the system is to be operated, and condensing temperature when minimum load exists.

## Application

Refrigeration systems experience load variations to some degree throughout the year and may use discharge bypass valves to balance compressor capacity with system load. Depending on the system size and type of compressor used, this valve type may be used in place of compressor cylinder unloaders or to handle the unloading requirements below the last step of cylinder unloading. Depending on the system components and configuration, the hot gas may be introduced directly into the suction line, in which case a desuperheating thermostatic expansion valve would be required to control the suction gas temperature, or the hot gas may be introduced into the evaporator inlet through a specially designed refrigerant distributor with an auxiliary side connection where it mixes with the cold refrigerant from the system thermostatic expansion valve to control the suction gas temperature before the gas reaches the compressor.

The location of the discharge bypass valve and the necessary accessories will depend on the type of system. Valve manufacturers' literature provides the proper locations and piping recommendations for their products.

## HIGH-SIDE FLOAT VALVES

### Operation

A high-side float valve controls the mass flow of refrigerant liquid entering the evaporator so it equals the rate at which the refrigerant gas is pumped from the evaporator by the compressor. [Figure 28](#) shows a cross section of a typical valve. The refrigerant liquid flows from the condenser into the high-side float valve body, where it raises the float and moves the valve pin in an opening direction, permitting the liquid to pass through the valve port, expand, and flow into the evaporator. Most of the system refrigerant charge is contained in the evaporator at all times. The high-side float system is a flooded system.

### Selection

For acceptable performance, the high-side float valve is selected for the refrigerant and a rated capacity neither excessively large nor too small. The orifice is sized for the maximum required capacity with the minimum pressure drop across the valve. The valve operated by the float may be a pin-and-port construction ([Figure 28](#)), a butterfly valve, a balanced double-ported valve, or a sliding gate or spool valve. The internal bypass vent tube allows installation of the high-side float valve near the evaporator and above the condenser without danger of the float valve becoming gas-bound. Some large-capacity valves use a high-side float valve

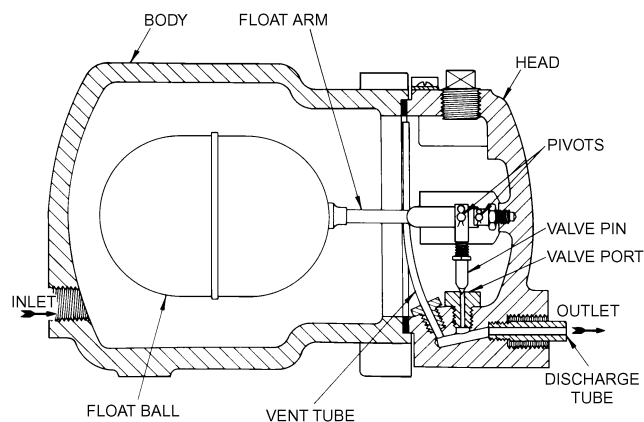


Fig. 28 High-Side Float Valve

for pilot operation of a diaphragm or piston spring-loaded expansion valve. This arrangement can provide improved modulation over a wide range of load and pressure-drop conditions.

## Application

A refrigeration system in which a high-side float valve is used consists ordinarily of a single evaporator, compressor, and condenser. The operating receiver or a liquid sump at the condenser outlet can be quite small. A full-sized receiver is required for pumping out the flooded evaporator. Under certain conditions, the high-side float valve may be used to feed more than one evaporator; consequently, additional control valves are required. The amount of refrigerant charge is critical with a high-side float valve. An excessive charge causes floodback, while an insufficient amount reduces system capacity.

## LOW-SIDE FLOAT VALVES

### Operation

The low-side float valve performs the same function as the high-side float valve, but it is connected to the low-pressure side of the system. When the evaporator liquid level drops, the float opens the valve. Refrigerant liquid then flows from the liquid line through the valve port and directly into the evaporator or surge drum. In another design, the refrigerant liquid flows through the valve port, passes through a remote feed line, and enters the evaporator through a separate connection. (A typical direct-feed valve construction is shown in [Figure 29](#).) The low-side float system is a flooded system.

### Selection

Low-side float valves are selected in the same manner as the high-side float valves discussed previously.

### Application

In the low-side float valve system, the refrigerant charge is not critical. The low-side float valve can be used with multiple evaporators such that some evaporators may be controlled by other low-side float valves and some by thermostatic expansion valves.

The float valve is mounted either directly in the evaporator or surge drum or in an external chamber connected to the evaporator or surge chamber by equalizing lines (i.e., a gas line at the top and a liquid line at the bottom). In the externally mounted type, the float valve is separated from the float chamber by a gland that maintains a quiet level of liquid in the float chamber for steady actuation of the valve.

In evaporators with high boiling rates or restricted liquid and gas passages, the boiling action of the liquid raises the refrigerant level during operation. When the compressor stops or the solenoid

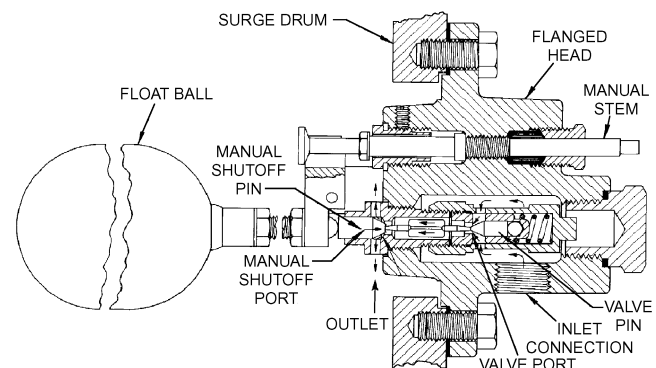


Fig. 29 Low-Side Float Valve

suction valve closes, the boiling action of the refrigerant liquid ceases, and the refrigerant level in the evaporator drops. Under these conditions, the high-pressure liquid line supplying the low-side float valve should be shut off by a solenoid liquid valve to prevent overfilling of the evaporator. Otherwise, excess refrigerant will enter the evaporator on the off cycle, which can cause floodback when the compressor starts or the solenoid suction valve opens.

When a low-side float valve is used, precautions must be taken that the float is in a quiet liquid level that falls properly in response to an increase in evaporator load and rises with a decrease in evaporator load. In low-temperature systems particularly, it is important that the equalizer lines between the evaporator and either the float chamber or the surge drum be generously sized to eliminate any reverse response of the refrigerant liquid level in the vicinity of the float. Where the low-side float valve is located in a nonrefrigerated room, the equalizing liquid and gas lines and the float chamber must be insulated to provide a quiet liquid level for the float.

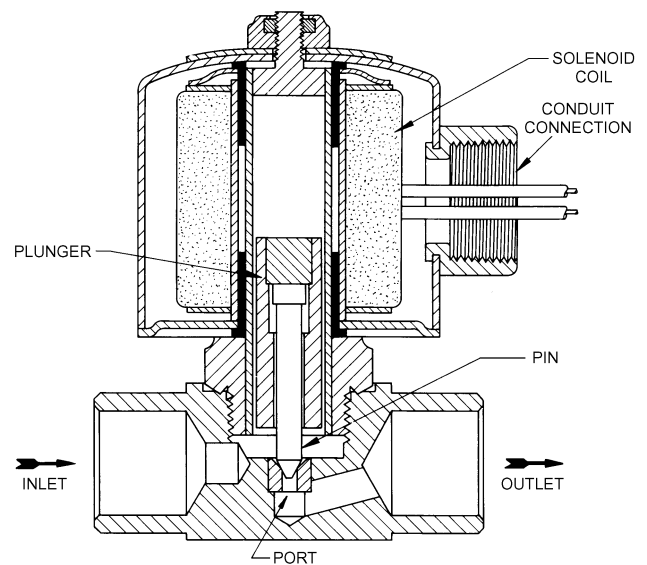
### SOLENOID VALVES

Solenoid valves, also called **solenoid-operated valves**, are comprised of a soft iron armature positioned in the central axis of a copper wire coil. When an electric current flows through the coil, a magnetic field is created that draws the moveable armature to it. The armature is adapted to open or close a valve port as it is moved by the magnetic field. This basic operating mechanism is adapted to a wide variety of valve designs and sizes for refrigerant service.

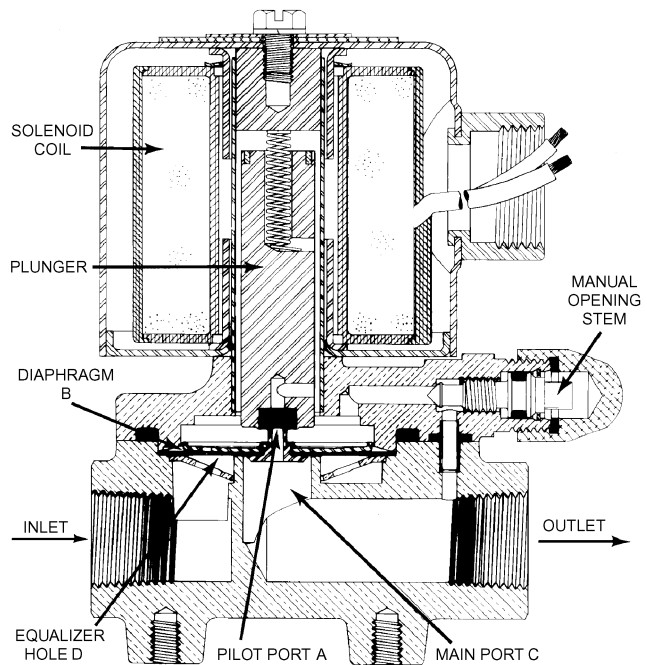
Solenoid valves for refrigerant service are typically two-position devices (i.e., solenoid energized or de-energized). In the energized mode, the armature is drawn into the coil by the magnetic field. The electromagnetic coil must provide the work required to overcome the spring or gravity plus the work necessary to open or close the valve. In the de-energized mode, the armature, sometimes called a plunger or core, is moved to the extended end of its stroke by a spring, or in some designs by gravity.

Refrigerant service solenoid valves have the movable armature, frequently referred to as the plunger, enclosed in a thin-walled non-magnetic metal tube (usually nonmagnetic stainless steel). One end of the tube is closed pressure-tight by welding or brazing a soft iron bearing magnetic metal plug into the tube. The open end is adapted to the valve body, usually in axial alignment with the valve port. This construction method eliminates the need for a dynamic stem seal between the solenoid operator and the valve. [Figure 30](#) shows a semi-hermetic construction in which the tube, top plug and lower nut are welded or brazed together. The tube assembly is threaded to the valve body using a metal-to-metal pressure-tight seal that eliminates the need for synthetic materials. Some small valves are made completely hermetic by welding or brazing the enclosing tube, containing the magnetically movable plunger assembly, to the valve body. Most often the connection between the magnetic assembly and the valve body is made pressure tight with synthetic gaskets or O rings, as shown in [Figure 31](#).

The copper wire electromagnetic coil, with its associated electrical insulation system, is closely fitted to the outer diameter of the enclosing tube. This arrangement places the coil and insulation outside of the pressurized refrigerant environment. The electromagnetic circuit includes the plunger, the top plug, the metallic housing surrounding the copper wire coil assembly, and any metal spacers or sleeves used to properly position the coil on the tube, as shown in [Figure 30](#). These components are fabricated of soft-iron-bearing magnetic materials and are absolutely essential to acceptable solenoid valve performance. Combined, they form a well-defined and complete magnetic circuit. Many contemporary designs employ molded resin coil assemblies that have the coil and outer soft iron housing encapsulated within the resin. This construction enhances heat dissipation, protects the electrical parts from moisture and mechanical damage, and simplifies field assembly.



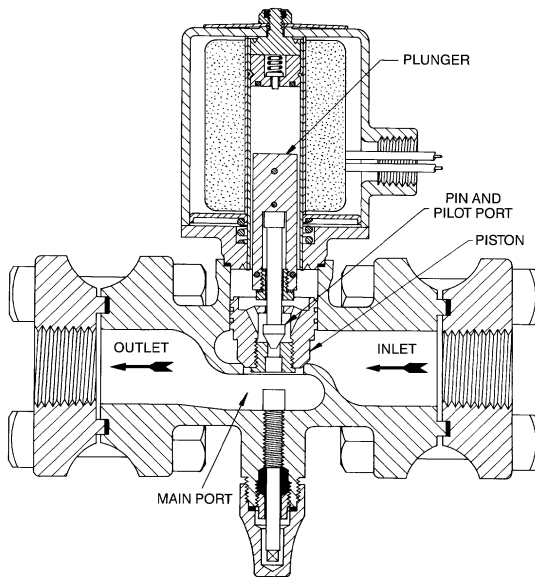
**Fig. 30** Normally Closed Direct-Acting Solenoid Valve with Hammer-Blow Feature



**Fig. 31** Normally Closed Pilot-Operated Solenoid Valve with Direct-Lift Feature

### Operation

A number of valve designs have been developed that can be reliably operated with relatively low-powered solenoids, which helps to minimize energy consumption. The major force that must be overcome by the solenoid operator to open a normally closed valve or close a normally open valve is related to the port area multiplied by the pressure differential across the valve when it is closed. The maximum pressure differential that a specific solenoid valve will reliably open against is called the maximum operating pressure differential (MOPD). To provide acceptable MOPD for refrigeration applications with reasonably powered solenoids it is necessary to design valves with small ports. Small-ported valves can satisfy low flow



**Fig. 32 Normally Closed Pilot-Operated Solenoid Valve with Hammer-Blow and Mechanically Linked Piston-Pin Plunger Features**

capacity requirements and pilot duty applications. Thus, direct-acting solenoid valves are limited to low-capacity or low-MOPD applications. Large-capacity and high-MOPD applications use pilot-operated valves similar to those shown in [Figures 31](#) and [32](#).

Solenoid valves are divided into two basic categories related to flow capacity and MOPD:

- **Direct-acting valves** (see [Figure 30](#)) are capable of relatively small flow capacities with MOPDs suitable for most refrigerant applications, are useful as pilots on larger valves, and can be designed for medium flow capacities with low MOPD.
- **Pilot-operated valves** (see [Figures 31](#) and [32](#)) are capable of large flow capacities with a full range of MOPDs suitable for refrigerant applications. They have small direct-acting valves imbedded in the main valve body that pilot the main valve. The opening of the pilot port creates a pressure imbalance within the main valve mechanism, causing it to open.

These basic categories are each divided into several sub-categories:

- **Two-way normally closed valves** have one inlet, one outlet, and one intermediate port that is closed when the solenoid is de-energized. This is by far the most commonly used configuration in a wide variety of refrigerant stop services.
- **Two-way normally open valves** have one inlet, one outlet, and one intermediate port that is open when the solenoid is de-energized. This configuration is particularly useful in applications requiring a valve that will “fail” to a normally open position.
- **Three-way diverting valves** have one inlet and two outlets; each outlet is associated with its own port so that when the solenoid is de-energized, flow from the common inlet exits via outlet 1 and when the solenoid is energized, outlet 1 is stopped and the flow exits via outlet 2. This type may be used to divert hot compressor discharge gas from the normal condenser to the heat reclaim heat exchanger.
- **Three-way mixing valves** have two inlets and one outlet, each inlet being associated with its own port so that when the solenoid is de-energized, refrigerant flows from inlet 1 to the common outlet, and when the solenoid is energized, refrigerant flows from inlet 2 to the common outlet. This style, in the direct-acting version, may be used to activate compressor cylinder unloading

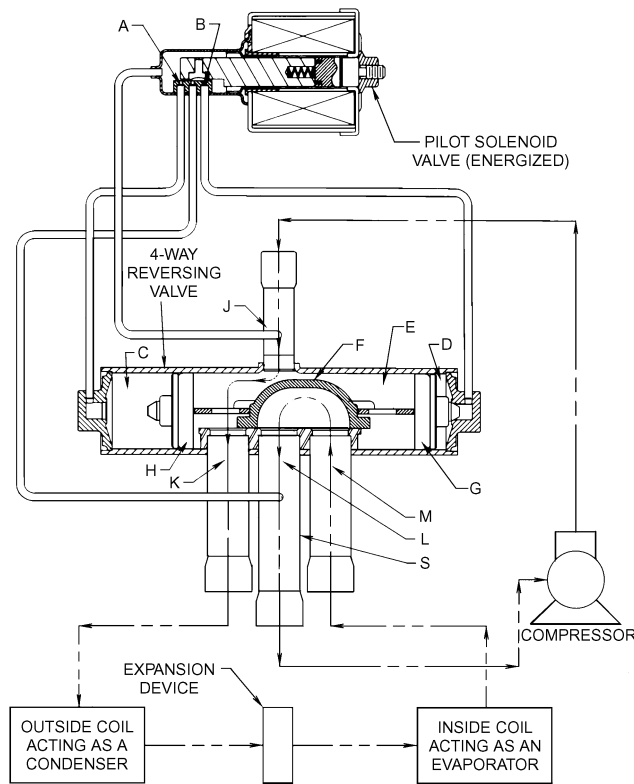
mechanisms or as a pilot for large gas-powered valves that use system high-side pressure to close normally open stop valves.

- **Four-way reversing valves** have two inlets and two outlets. One connection always functions as an inlet. Another one of the four always functions as an outlet. Flow in the remaining two connections is reversed when the solenoid is energized or de-energized. This configuration is used almost exclusively to switch heat pumps between cooling and heating modes. The direct-acting version is used to pilot the main valve, and both main and pilot valves are most often hybrid spool valves. [Figures 33](#) and [34](#) show these valves schematically in both the energized and de-energized modes.

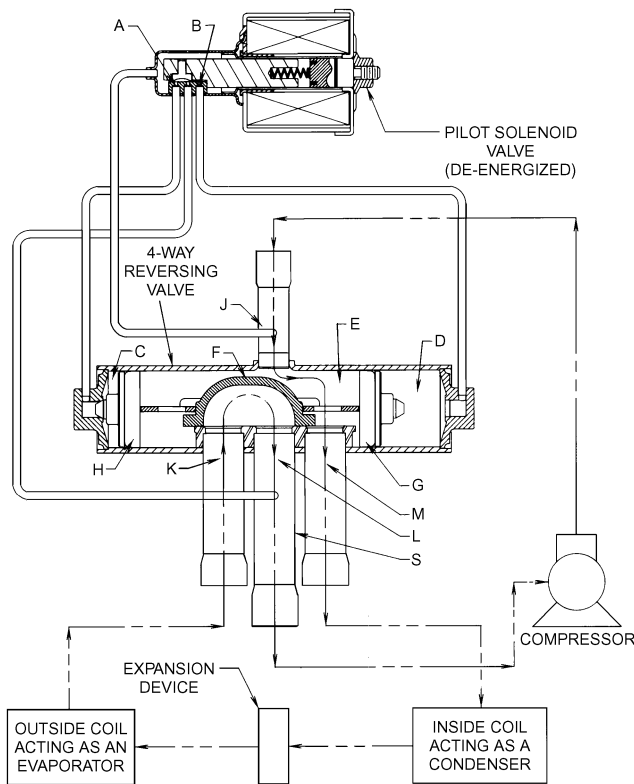
[Figure 30](#) shows a direct-acting normally closed two-way valve with a long-stroke solenoid that employs a “lost-motion hammer-blow” mechanism to impact the valve pin and overcome the pressure differential force holding the valve closed. This valve design, while providing some additional opening capability, is less reliable with respect to MOPD repeatability and has a shorter cyclic life due to the high-momentum impacts between plunger, pin, and top plug. It also relies entirely on gravity to move the valve in the closing direction when the solenoid is de-energized. This reliance limits the installed position. This type of valve must be installed in an upright position with the magnetic assembly on top.

A common design of direct-acting solenoid is the direct-lift type such as the solenoid operator portion of the pilot operated valve in [Figure 31](#). The short stroke minimizes mechanical damage related to impact of the plunger with the top plug and minimizes inrush current in alternating current systems. The closing spring permits installation in any position. Some solenoids of this short-stroke design can survive extended periods of time in failure mode (i.e., when the coil is energized but the valve fails to open because of excessive pressure, low voltage, or other reasons) without significant damage to the coil.

[Figure 31](#) illustrates a pilot-operated valve that employs a semi-flexible diaphragm to operate the main valve. When the solenoid is energized, the pilot port (shown centered over the main port) opens and allows the pressure above the diaphragm to diminish as it discharges to low pressure at the valve outlet. The higher valve inlet pressure exerted on the underside of the diaphragm surrounding the main port causes the diaphragm to move upward, opening the main port to full flow. The ratio of diaphragm area to port area as well as the relative flow rates of the bleed hole D and the pilot port are carefully balanced in the valve design. This ensures that adequate opening force is developed to meet the MOPD requirements of the valve specification. When the solenoid is de-energized, the plunger moves down, closing the pilot port, and inlet pressure flowing through bleed hole D allows the pressure above the diaphragm to equalize with valve inlet pressure. The entire top of the diaphragm is exposed to inlet pressure; on the bottom side, only the annular area surrounding the port is exposed to inlet pressure; the center portion is exposed to outlet pressure. The net effect of the pressure and area differences is a force that pushes the diaphragm down to close the main port. The spring in the top of the plunger causes the plunger to follow the falling pilot port, keeping it sealed and providing additional downward push on the diaphragm to help close the main port. In the valve of [Figure 31](#), the pilot operator is centrally located directly over the main port. In this configuration, the diaphragm stroke is limited. When larger diaphragm strokes are required for greater flow capacity, the pilot operator and pilot port are relocated to a point beyond the perimeter of the diaphragm over the main valve outlet connection. Separate flow passages in the valve body are provided to conduct pilot port flow from the top of the diaphragm to the valve outlet. This arrangement is usually called an “offset pilot” and retains the benefits of a short-stroke solenoid operator while allowing a diaphragm stroke commensurate with full flow through the main port.



**Fig. 33 Four-Way Slide Refrigerant-Reversing Valve Used in Cooling (or Defrosting) Cycle of Refrigeration System**



**Fig. 34 Four-Way Slide Refrigerant-Reversing Valve Used in Heating Cycle of Refrigeration System**

The pilot-operated valve shown in [Figure 32](#) operates according to the same principles as the diaphragm valve described above. However, this valve uses a piston instead of a diaphragm. The carefully controlled annular clearance between piston and the inside bore of the valve body is often used to perform the function of equalizer hole D (shown in [Figure 31](#)), eliminating the need for a separate bleed hole in the piston. The valve in [Figure 32](#) uses a long-stroke hammer-blow pilot operator, which permits long main valve strokes to accommodate large flow capacity requirements without offsetting the pilot. The centered pilot allows mechanically linking the main piston to the plunger assembly to help hold the valve wide open at near zero pressure drops in low-temperature suction line applications.

[Figure 33](#) shows a four-way valve piloted by a four-way direct-acting valve shown in the energized position. The main valve slide F is positioned to connect flow path M, coming from the evaporator (inside coil), to flow path L going to compressor suction through tube S. At the same time, high-pressure hot gas flows from the compressor discharge through tube J, around slide F and through flow path K to the condenser (outside coil). High pressure from tube J passes through pilot port A to main valve chamber C. The main valve slide is held in this position by the high pressure in chamber C pushing piston H to the right. When the pilot solenoid is de-energized, the pilot valve plunger is moved to the left by the spring (as shown in [Figure 34](#)), allowing high pressure from tube J to flow through pilot port B to chamber D at the right-hand end of the main valve body. Simultaneously, chamber C is connected through pilot port A to low pressure in tube S. The pressure in chamber D rises as the pressure in chamber C falls, driving slide F to the left as shown in [Figure 34](#). The flow in paths K and M reverse and the outside coil becomes the evaporator while the inside coil becomes the condenser. The system has been transferred into heating mode. When the pilot solenoid is re-energized, the processes reverse and the system reverts to cooling mode.

**Application**

Solenoid valves are generally vulnerable to particles in the refrigerant stream and should be protected by a filter-drier.

Valves that are attitude-sensitive must be carefully oriented and properly supported to ensure reliable operation. Care must be exercised to avoid overheating sensitive valve parts when the installation process involves soldering, brazing, or welding.

Electrical service provided to solenoid operators deserves careful attention. Most solenoid valve performance failures are related to improper or inadequate provision of electric power to the solenoid. Undervoltage when attempting to open will seriously compromise MOPD and cause failure to open. The continued application of power to an alternating current (AC) solenoid coil installed on a valve that is unable to open will overheat the coil and may lead to premature coil failure (even at undervoltage). Although direct current solenoids may tolerate a little more voltage variation, overvoltage leads to overheating (even when the valve successfully opens) and results in shortened coil life; undervoltage will reduce the MOPD.

The probability of experiencing undervoltage at the moment of opening with AC systems increases when a control transformer of limited capacity supplies power to the solenoid. This type of transformer is commonly used to supply power to low-voltage control systems using class 2 wiring. The situation is aggravated when more than one device served by the same transformer is energized simultaneously.

**CONDENSING WATER REGULATORS**

Condensing water regulators are used for head pressure control during year-round operation of refrigeration systems. Additional information can be found in [Chapter 13, Condenser Water Systems](#)

of the *ASHRAE Handbook—HVAC Systems and Equipment*, in the section on Operation Optimization in [Chapter 46, Design and Application of Controls of the HVAC Handbook—Applications Handbook](#), and in [Chapter 2, System Practices for Halocarbon Refrigerants](#) of this volume under Head Pressure Control for Refrigerant Condensers.

### Two-Way Regulators

Condensing water regulators modulate the quantity of water passing through a water-cooled refrigerant condenser in response to the condensing pressure. They are available for use with most refrigerants, including ammonia (R-717). Most manufacturers stress that these valves are designed for use only as operating devices. Where system closure, improper flow, or loss of pressure due to valve failure can result in personal injury, damage, or loss of property, separate safety devices must be added to the system.

These devices are used on vapor-cycle refrigeration systems to maintain a condensing pressure that loads but does not overload the compressor motor. The regulator automatically modulates to correct for both variations in temperature or pressure of the water supply and variations in the quantity of refrigerant gas being pumped into the condenser.

**Operation.** The condensing water regulator consists of a valve and an actuator that are linked together, as shown in [Figure 35](#). The actuator consists of a metallic bellows and adjustable spring combination connected to the system condensing pressure.

After a compressor starts, the condensing pressure begins to rise. When the opening pressure setting of the regulator spring is reached, the bellows moves to open the valve disk gradually. The regulator continues to open as the condensing pressure rises until the water flow balances the required heat rejection. At this point the condensing pressure is stabilized. When the compressor stops, the continuing water flow through the regulator causes the condensing pressure to drop gradually and the regulator becomes fully closed when the opening pressure setting of the regulator is reached.

**Selection.** To avoid hunting or internal erosion due to high pressure drops through an oversized valve because it operates only partially open for most of its duty cycle, the regulator should be selected from the manufacturer's data on the basis of maximum required flow, minimum available pressure drop, water temperature, and system operating conditions. Also, depending on the specific refrigerant being used, special components may be required (e.g., stainless steel rather than brass bellows for ammonia.)

The water flow required depends on condenser performance, the temperature of available water, the quantity of heat that must be rejected to the water, and the allowable exit water temperature. For a given opening of the valve seat, which corresponds to a given pressure rise above the regulator opening point, the flow rate handled by a given size of water regulator is a function of the available water-pressure drop across the valve seat.

**Application.** Because there are two types of control action available (direct-acting or reverse-acting), these regulators can be used for various applications: water-cooled condensers, bypass service on refrigeration systems, ice machines, and heat pump systems that control water temperature. For equipment with a large water flow, a small regulator is used as a pilot valve for a diaphragm main valve.

Manufacturers of these types of devices have technical literature to assist in applying their products to the customer's system.

### Three-Way Regulators

These regulators are similar to two-way regulators, but they have an additional port, which opens to bypass water around the condenser as the port controlling water flow to the condenser closes ([Figure 36](#)). Thus, the cooling tower decking or sprays and the circulating pump receive a constant supply of water, although the water supply to individual or multiple condensers is modulated for control.

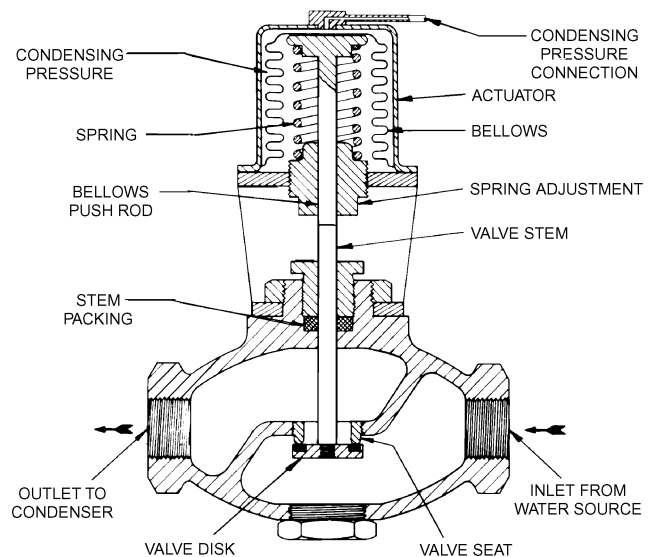


Fig. 35 Two-Way Condensing Water Regulator

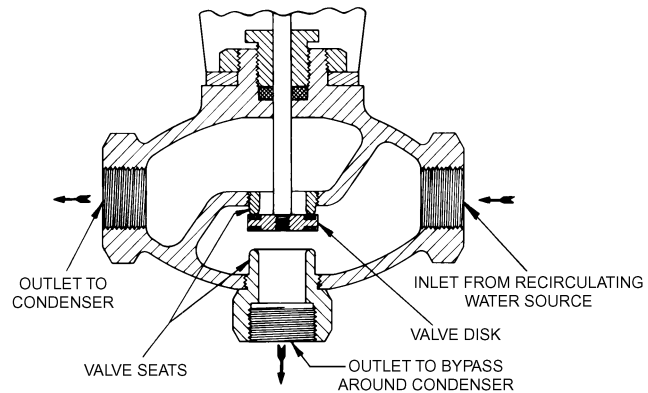


Fig. 36 Three-Way Condensing Water Regulator

**Operation.** The three-way regulator operates in a manner similar to the two-way regulator. Low refrigerant head pressure, which may be the result of low cooling tower water temperature, causes the cooling ability of the refrigeration system to fall off rapidly. The three-way regulator senses the compressor head pressure and allows cooling water to flow to the condenser, bypass the condenser, or flow to both the condenser and bypass line to provide correct refrigerant head pressures.

The regulator permits water flow to the tower through the bypass line, even though the condenser does not require cooling. This provides an adequate head of water at the tower at all times so the tower can operate efficiently with a minimum of maintenance on nozzles and wetting surfaces.

**Selection.** Selection considerations for three-way regulators are the same as those for two-way regulators, including the cautions about oversizing.

**Application.** Pressure-actuated three-way regulators are for condensing units cooled by atmospheric or forced draft cooling towers requiring individual condensing pressure control. They may be used on single or multiple condenser piping arrangements to the tower to provide the most economical and efficient use. These regulators must be supplemented by other means if cooling tower systems are to be operated in freezing weather. An indoor sump is usually required, and a temperature-actuated three-way water

control valve periodically diverts all of the condenser leaving water directly to the sump when the water becomes too cold.

Strainers are not generally used with water regulators because they tend to increase cleaning and servicing requirements.

### CHECK VALVES

Refrigerant check valves are normally used in refrigerant lines in which pressure reversals can cause undesirable reverse flows. A check valve is usually opened by a portion of the pressure drop. Closing usually occurs either when a reversal of pressure takes place or when the pressure drop across the check valve is less than the minimum opening pressure drop in the normal flow direction.

The conventional large check valve uses piston construction in a globe valve body, whereas in-line designs are common for 2 in. or smaller valves. Either design may include a closing spring; a heavier spring gives more reliable and tighter closing but requires greater pressure to open. Although conventional check valves may be designed to open at less than 1 psi, they may not be reliable below  $-25^{\circ}\text{F}$  because the light closing springs can not overcome the viscous lubricant.

### Seat Materials

Although precision metal seats may be manufactured nearly bubble-tight, they are not economical for refrigerant check valves. Seats made of synthetic elastomers provide excellent sealing at medium and high temperatures, but may leak at low temperatures due to their lack of resilience. Because high temperatures deteriorate most elastomers suitable for refrigerants, plastic materials have become more widely used, despite being susceptible to damage by large pieces of foreign matter.

### Applications

In compressor discharge lines, check valves are used to prevent flow from the condenser to the compressor during the off cycle or to prevent flow from an operating compressor to an idle compressor. Although a 2 to 6 psi pressure drop is tolerable, the check valve must resist pulsations cause by the compressor and the temperature of discharge gas. Also, the valve must be bubble-tight to prevent liquid refrigerant from accumulating at the compressor discharge valves or in the crankcase.

In liquid lines, a check valve prevents reverse flow through the unused expansion device on a heat pump or prevents backup into the low-pressure liquid line of a recirculating system during a defrosting. Although a 2 to 6 psi pressure drop is usually acceptable, the check-valve seat must be bubble-tight.

In the suction line of a low-temperature evaporator, a check valve may be used to prevent the transfer of refrigerant vapor to a lower-temperature evaporator on the same suction main. In this case, the pressure drop must be less than 2 psi, the valve seating must be reasonably tight, and the check valve must be reliable at low temperatures.

In hot-gas defrost lines, check valves may be used in the branch hot-gas lines connecting the individual evaporators to prevent crossfeed of refrigerant during the cooling cycle when the defrost operation is not taking place. In addition, check valves are used in the hot-gas line between the hot-gas heating coil in the drain pan and the evaporator to prevent pan coil sweating during the refrigeration cycle. Tolerable pressure drop is typically 2 to 6 psi, seating must be nearly bubble-tight, and seat materials must withstand high temperatures.

Oversized check valves may chatter or pulsate.

### RELIEF DEVICES

A refrigerant relief device has either a safety or functional use. A safety relief device is designed to relieve positively at its set

pressure for one crucial occasion without prior leakage. The relief may be to the atmosphere or to the low-pressure side.

A functional relief device is a control valve that may be called on to open, modulate, and close with repeatedly accurate performance. Relief is usually from a portion of the system at higher pressure to a portion at lower pressure. Design refinements of the functional relief valve usually make it unsuitable or uneconomical as a safety relief device.

### Safety Relief Valves

These valves are most commonly a pop-type design, which open abruptly when the inlet pressure exceeds the outlet pressure by the valve setting pressure (Figure 37). Seat configuration is such that once lift begins, the resulting increased active seat area causes the valve seat to pop wide open against the force of the setting spring. Because the flow rate is measured at a pressure of 10% above the setting, the valve must open within this 10% increase in pressure.

This relief valve operates on a fixed pressure differential from inlet to outlet. Because the valve is affected by back pressure, a rupture disk must not be installed at the valve outlet.

Relief valve seats are made of metal, plastic, lead alloy, or synthetic elastomers. Elastomers are commonly used because they have greater resilience and, consequently, reseal more tightly than other materials. Some valves that have lead-alloy seats have an emergency manual reseating stem that permits reforming the seating surface by tapping the stem lightly with a hammer. The advantages of the pop-type relief valve are simplicity of design, low initial cost, and high discharge capacity.

Capacities of pressure relief valves are determined by test in accordance with the provisions of the ASME Boiler and Pressure Vessel Code. Relief valves approved by the National Board of Boiler and Pressure Vessel Inspectors are stamped with the code symbol, which consists of the letters UV in a cloverleaf design with the letters NB stamped directly below this symbol. In addition, the pressure setting and capacity are stamped on the valve.

When relief valves are used on pressure vessels of 10 ft<sup>3</sup> internal gross volume or more, a relief system consisting of a three-way valve and two relief valves in parallel is required.

**Pressure Setting.** The maximum pressure setting for a relief device is limited by the design working pressure of the vessel to be protected. Pressure vessels normally have a safety factor of 5.

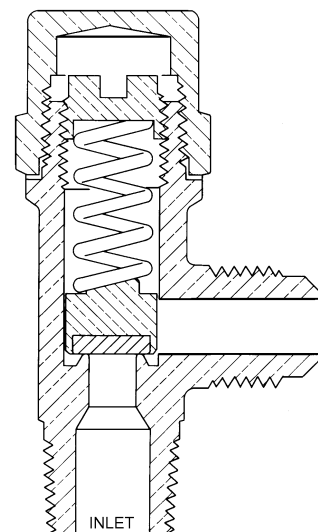


Fig. 37 Pop-Type Safety Relief Valves

Therefore, the minimum bursting pressure is five times the rated design working pressure. The relief device must have enough discharge capacity to prevent the pressure in the vessel from rising more than 10% above its design pressure. Because the capacity of a relief device is measured at 10% above its stamped setting, the setting cannot exceed the design pressure of the vessel.

To prevent loss of refrigerant through pressure relief devices during normal operating conditions, the relief setting must be substantially higher than the system operating pressure. For rupture members, the setting should be 50% above a static system pressure and 100% above a maximum pulsating pressure. Failure to provide this margin of safety causes fatigue of the frangible member and rupture well below the stamped setting.

For relief valves, the setting should be 25% above maximum system pressure. This safety factor provides sufficient spring force on the valve seat to maintain a tight seal and still allow for setting tolerances and other factors that cause settings to vary. Although relief valves are set at the factory to be close to the stamped setting, the variation may be as much as 10% after the valves have been stored or placed in service.

**Discharge Piping.** The size of the discharge pipe from the pressure relief device or fusible plug must not be less than the size of the pressure relief device or fusible plug outlet. The maximum length of the discharge piping is provided in a table or may be calculated from the formula provided in ASHRAE *Standard 15*.

**Selection and Installation.** When selecting and installing a relief device,

- Select a relief device with sufficient capacity for code requirements and one suitable for the type of refrigerant used.
- Use the proper size and length of discharge tube or pipe.
- Do not discharge the relief device prior to installation or when pressure-testing the system.
- For systems containing large quantities of refrigerant, use a three-way valve and two relief valves.
- Install a pressure vessel that permits the relief valve to be set at least 25% above the maximum system pressure.

### Functional Relief Valves

Functional relief valves are usually diaphragm types in which the system pressure acts on a diaphragm that lifts the valve disk from the seat (Figure 38). The other side of the diaphragm is exposed to both the adjusting spring and atmospheric pressure. The ratio of effective diaphragm area to seat area is high, so the outlet pressure has little effect on the operating point of the valve.

Because the lift of the diaphragm is not great, the diaphragm valve is frequently built as the pilot or servo of a larger piston-operated main valve to provide both sensitivity and high flow capacity. Construction and performance are similar to the previously described pilot-operated evaporator-pressure regulator, except that diaphragm valves are constructed for higher pressures. Thus, the valves are suitable for use as defrost relief from evaporator to suction pressure, as large-capacity relief from a pressure vessel to the low side, or as a liquid refrigerant pump relief from pump discharge to the accumulator to prevent excessive pump pressures when some evaporators are valved closed.

### Other Safety Relief Devices

The **fusible plug** and the **rupture disk** (Figure 39) provide similar safety relief. The former contains a fusible member that melts at a predetermined temperature corresponding to the safe saturation pressure of the refrigerant, but is limited in application to pressure vessels with internal gross volumes of 3 ft<sup>3</sup> or less and internal diameters of 6 in. or less. The rupture member contains a preformed disk designed to rupture at a predetermined pressure. These devices may be used as stand-alone devices or installed at the inlet to a safety relief valve.

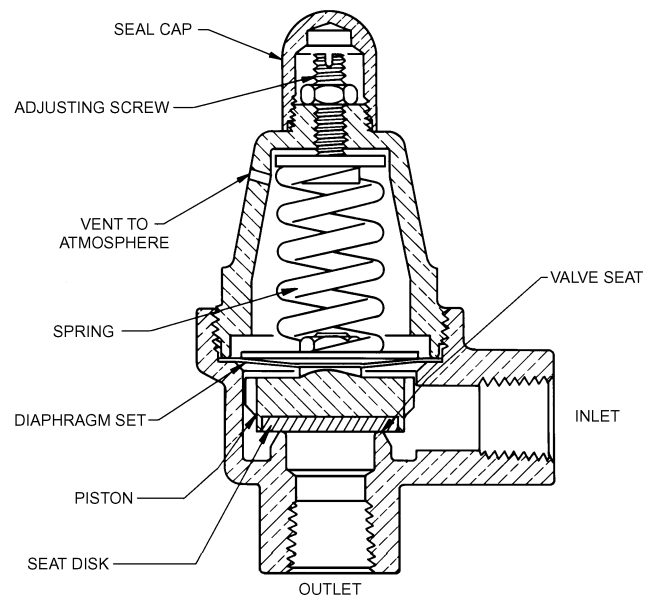


Fig. 38 Diaphragm Relief Valve

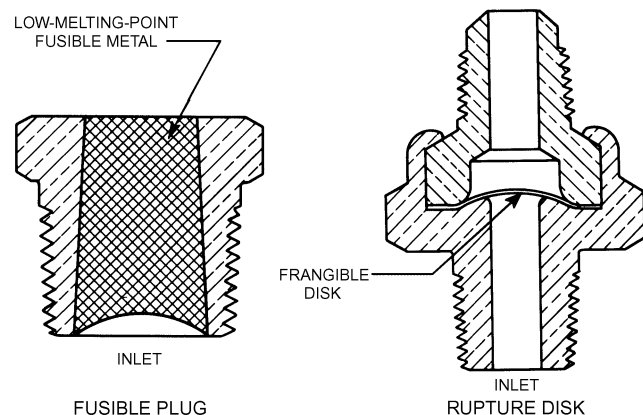


Fig. 39 Safety Relief Devices

When these devices are installed in series with a safety relief valve, the chamber created by the two valves must have a pressure gage or other suitable indicator. A rupture disk will not burst at its design pressure if back pressure builds up in the chamber.

The rated relieving capacity of a relief valve alone must be multiplied by 0.9 when it is installed in series with a rupture disk (unless the relief valve has been rated in combination with the rupture disk).

**Discharge Capacity.** The minimum required discharge capacity of the pressure relief device or fusible plug for each pressure vessel is determined by the following formula, specified by ASHRAE *Standard 15*:

$$C = fDL \quad (2)$$

where

$C$  = minimum required air discharge capacity of relief device, lb/min

$D$  = outside diameter of vessel, ft

$L$  = length of vessel, ft

$f$  = factor dependent on refrigerant, as shown in Table 2

Equation (2) determines the required relief capacity for a pressure vessel containing liquid refrigerant. See ASHRAE *Standard 15*

**Table 2 Values of  $f$  for Discharge Capacity of Pressure Relief Devices**

Refrigerant	Value of $f$
When used on the low side of a limited-charge cascade system:	
R-170, R-744, R-1150	1.0
R-13, R-13B1, R-503	2.0
R-14	2.5
Other applications:	
R-717	0.5
R-11, R-40, R-113, R-123, R-142b, R-152a, R-290, R-600, R-600a, R-611, R-764	1.0
R-12, R-22, R-114, R-134a, R-C 318, R-500, R-1270	1.6
R-115, R-502	2.5

**Notes:**

- The values of  $f$  listed do not apply if fuels are used within 20 ft of the pressure vessel. In this case, the methods in API RP 520 shall be used to size the pressure relief device.
- When one pressure relief device or fusible plug is used to protect more than one pressure vessel, the required capacity must be the sum of the capacities required for each pressure vessel.
- For refrigerants not listed, consult ASHRAE *Standard 15*.

for other relief device requirements, including the relief of overpressure due to compressor flow rate capacity.

## DISCHARGE-LINE LUBRICANT SEPARATORS

The **discharge-line lubricant separator** removes lubricant from the discharge gas of helical rotary (screw) and reciprocating compressors. Lubricant is separated by (1) reducing gas velocity, (2) changing direction of flow, (3) impingement on baffles, (4) mesh pads or screens, (5) centrifugal force, or (6) coalescent filters. The separator reduces the amount of lubricant reaching the low-pressure side, helps maintain the lubricant charge in the compressor sump, and muffles the sound of the gas flow.

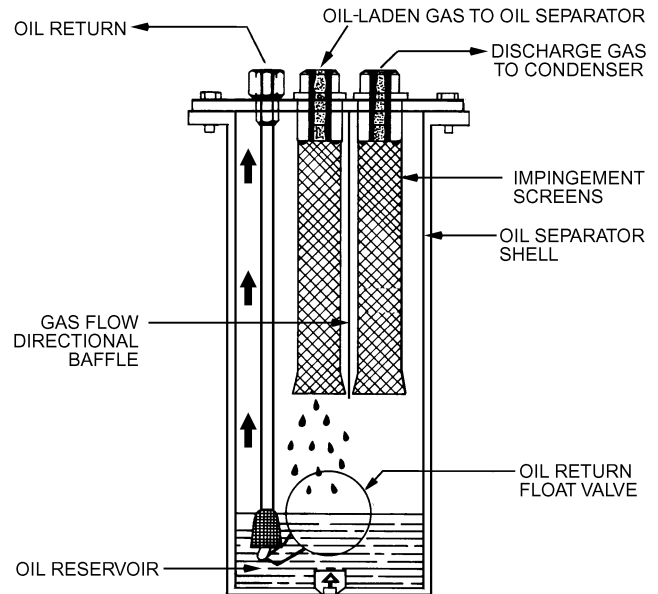
**Figure 40** shows one type of separator incorporating inlet and outlet screens and a high-side float valve. A space below the float valve allows for dirt or carbon sludge. When lubricant accumulates it raises the float ball, then passes through a needle valve and returns to the low-pressure crankcase. When the level falls, the needle valve closes, preventing the release of hot gas into the crankcase. Insulation and electric heaters may be added to prevent the refrigerant from condensing when the separator is exposed to low temperatures. A wide variety of horizontal and vertical flow separators is manufactured with one or more of such elements as centrifuges, baffles, wire mesh pads, or cylindrical filters.

### Selection

Separators are usually given capacity ratings for several refrigerants at several suction and condensing temperatures. Another rating method gives the capacity in terms of compressor displacement volume. Some separators also show a marked reduction in separation efficiency at some stated minimum capacity. Because the compressor capacity increases when the suction pressure is raised or the condensing pressure is lowered, the system capacity at its lowest compression ratio should be the criterion for selecting the separator.

### Application

Discharge-line lubricant separators are commonly used for ammonia or hydrocarbon refrigerant systems to reduce fouling in the evaporator. With lubricant-soluble halocarbon refrigerants, only certain flooded systems, low-temperature systems, or systems with

**Fig. 40 Discharge-Line Lubricant Separator**

long suction lines or other lubricant return problems may need lubricant separators. (See [Chapter 2. System Practices for Halocarbon Refrigerants](#) and [Chapter 3. System Practices for Ammonia Refrigerant](#) in this volume for more information about lubricant separators.)

## CAPILLARY TUBES

Every refrigerating system requires a pressure-reducing device to meter the flow of refrigerant from the high-pressure side to the low-pressure side of the refrigerating system according to load demand. The capillary tube is especially popular for smaller single-compressor/single-evaporator systems such as household refrigerators and freezers, dehumidifiers, and room air conditioners. Capillary tube use may extend to larger single-compressor/single-evaporator systems, such as unitary air conditioners up to 10 tons capacity.

The capillary operates on the principle that liquid passes through it much more readily than vapor. It is a length of drawn copper tubing with a small inner diameter. When used for controlling refrigerant flow, it connects the outlet of the condenser to the inlet of the evaporator. The term “capillary tube” is a misnomer because the inner bore, though narrow, is much too large to allow capillary action. In some applications, the capillary tube is soldered to the suction line and the combination is called a **capillary tube-suction line heat-exchanger system**. Refrigeration systems that use a capillary tube without the heat exchanger relationship are often referred to as **adiabatic capillary tube systems**.

A high-pressure liquid receiver is not normally used with a capillary tube; consequently, less refrigerant charge is needed. In a few applications, such as household refrigerators, freezers, room air conditioners, and heat pumps, a suction line accumulator may be used. Because the capillary tube allows pressure to equalize when the refrigerator is off, a compressor motor with a low starting torque may be used. A capillary tube system does not control as well over as wide a range of conditions as does a thermostatic expansion valve; however, a capillary tube may be less expensive and may provide adequate control for some systems.

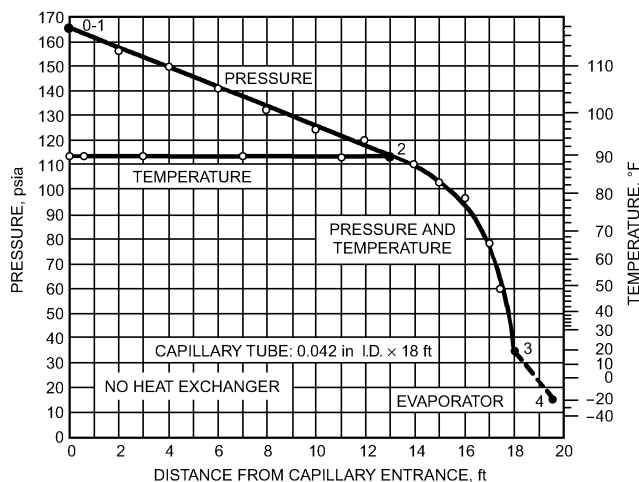
## Theory

A capillary tube passes liquid much more readily than vapor due to the increased volume of the vapor; as a result, it is a practical metering device. When a capillary tube is sized to permit the desired flow of refrigerant, the liquid seals its inlet. If the system becomes unbalanced, some vapor (uncondensed refrigerant) enters the capillary tube. This vapor reduces the mass flow of refrigerant considerably, which increases condenser pressure and causes subcooling at the condenser exit and capillary tube inlet. The result is an increase of the mass flow of refrigerant through the capillary tube. If properly sized for the application, the capillary tube compensates automatically for load and system variations and gives acceptable performance over a limited range of operating conditions.

A common flow condition is to have subcooled liquid at the entrance to the capillary tube. Bolstad and Jordan (1948) described the flow behavior from temperature and pressure measurements along the tube (Figure 41) as follows:

With subcooled liquid entering the capillary tube, the pressure distribution along the tube is similar to that shown in the graph. At the entrance to the tube, section 0-1, a slight pressure drop occurs, usually unreadable on the gauges. From point 1 to point 2, the pressure drop is linear. In the portion of the tube 0-1-2, the refrigerant is entirely in the liquid state, and at point 2, the first bubble of vapor forms. From point 2 to the end of the tube, the pressure drop is not linear, and the pressure drop per unit length increases as the end of the tube is approached. For this portion of the tube, both the saturated liquid and saturated vapor phases are present, with the percent and volume of vapor increasing in the direction of flow. In most of the runs, a significant pressure drop occurred from the end of the tube into the evaporator space.

With a saturation temperature scale corresponding to the pressure scale superimposed along the vertical axis, the observed temperatures may be plotted in a more efficient way than if a uniform temperature scale were used. The temperature is constant for the first portion of the tube 0-1-2. At point 2, the pressure has dropped to the saturation pressure corresponding to this temperature. Further pressure drop beyond point 2 is accompanied by a corresponding drop in temperature, the temperature being the saturation temperature corresponding to the pressure. As a consequence, the pressure and temperature lines coincide from point 2 to the end of the tube.



**Fig. 41 Pressure and Temperature Distribution Along Typical Capillary Tube**  
(Bolstad and Jordan 1948)

Mikol (1963) and Li et al. (1990) showed that generation of the first vapor bubble does not occur at the point where the liquid pressure reaches the saturation pressure (point 2 on Figure 41), but rather the refrigerant remains in the liquid phase for some limited length past point 2, reaching a pressure below the saturation pressure. This delayed evaporation, often referred to as a metastable or superheated liquid condition, must be accounted for in analytical modeling of the capillary tube, or the mass flow rate of refrigerant will be underestimated (Kuehl and Goldschmidt 1991; Wolf et al. 1995).

The rate of refrigerant flow through a capillary tube always increases with an increase in inlet pressure. Flow rate also increases with a decrease in external outlet pressure down to a certain critical value, below which the flow does not change (choked flow). Figure 41 illustrates a case in which the outlet pressure inside the capillary tube has reached the critical value (point 3), which is higher than the external pressure (point 4). Such a condition is typical for normal operation. The point at which the first gas bubble appears is called the **bubble point**. The preceding portion of capillary tube is called the **liquid length**, and that following is called the **two-phase length**.

## System Design Factors

A capillary tube must be compatible with other components. In general, once the compressor and heat exchangers have been selected to meet the required design conditions, the capillary tube size and system charge are determined. However, detailed design considerations may be different for different applications (e.g., domestic refrigerator, window air conditioner, residential heat pump).

Capillary tube size and system charge together are used to determine subcooling and superheat for a given design. Performance at off-design conditions should also be checked. Capillary tube systems are generally much more sensitive to the amount of refrigerant charge than expansion valve systems.

The high-pressure side must be designed for use with a capillary tube. To prevent rupture in case the capillary tube becomes blocked, the high-side volume should be sufficient to contain the entire refrigerant charge. A sufficient refrigerant storage volume (such as additional condenser tubes) may also be needed to protect against excessive discharge pressures during high-load conditions.

Pressure equalization during the off period is another concern in designing the high side. When the compressor stops, refrigerant continues to pass through the capillary tube from the high side to the low side until pressures are equal. If liquid is trapped in the high side, it will evaporate there during the off cycle, pass through the capillary tube to the low side as a warm gas, condense, and add latent heat to the evaporator. Therefore, good drainage of the liquid to the capillary tube during this equalization interval should be provided. Liquid trapping may also increase the time for the pressure to equalize after the compressor stops. If this interval is too long, pressures may not be sufficiently equalized to permit low-starting-torque motor compressors to start when the thermostat calls for cooling.

The maximum quantity of refrigerant is in the evaporator during the off cycle and the minimum during the running cycle. The suction piping should be arranged to reduce the adverse effects of the variable-charge distribution. A suitable suction line accumulator is sometimes needed.

## Capacity Balance Characteristic

The selection of a capillary tube depends on the application and anticipated range of operating conditions. One approach to the problem involves the concept of **capacity balance**. A refrigeration system operates at capacity balance when the resistance of the capillary tube is sufficient to maintain a liquid seal at its entrance

without excess liquid accumulating in the high side (Figure 42). Only one such capacity balance point exists for any given compressor discharge pressure. A curve through the capacity balance points for a range of compressor discharge and suction pressures is called the capacity balance characteristic of the system. Such a curve is shown in Figure 43. Ambient temperatures are drawn on the chart for a typical air-cooled system. A given set of compressor discharge and suction pressures associated with condenser and evaporator pressure drops establish the capillary tube inlet and outlet pressures.

The capacity balance characteristic curve for any combination of compressor and capillary tube may be determined experimentally by the arrangement shown in Figure 44. Although Figure 44 shows the capillary tube suction line heat exchanger application, a similar test set-up without heat exchange would be used for adiabatic capillary tube systems. This test arrangement makes it possible to vary the suction and discharge pressures independently until capacity balance is obtained. The desired suction pressure may be obtained

by regulating the heat input to the low side, usually by electric heaters. The desired discharge pressure may be obtained by a suitably controlled water-cooled condenser. A liquid indicator is located at the entrance to the capillary tube. The usual test procedure is to hold the high-side pressure constant and, with gas bubbling through the sight glass, slowly increase the suction pressure until a liquid seal forms at the capillary tube entrance. Repeating this procedure at various discharge pressures determines the capacity balance characteristic curve similar to that shown in Figure 43. This equipment may also be used as a calorimeter to determine the capacity of the refrigerating system.

**Optimum Selection and Refrigerant Charge**

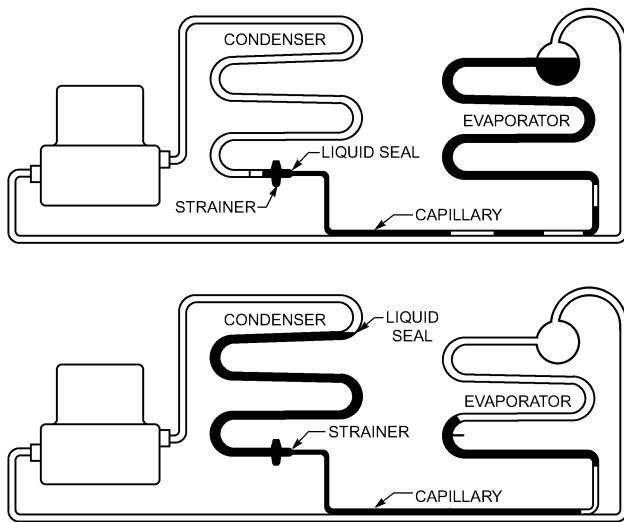
Whether the initial capillary tube selection and charge are optimum for the unit is always questioned, even in such simple applications as a room air-conditioning unit. The refrigerant charge in the unit can be varied using a small refrigerant bottle (valved off and sitting on a scale) connected to the circuit. The interconnecting line must be flexible and arranged so that it is filled with vapor instead of liquid. The charge is brought in or removed from the unit by heating or cooling the bottle.

The only test for varying the capillary tube restriction is to remove the tube, install a new capillary tube, and determine the optimum charge, as outlined previously. A method occasionally used is to pinch the capillary tube to determine whether increased resistance is needed.

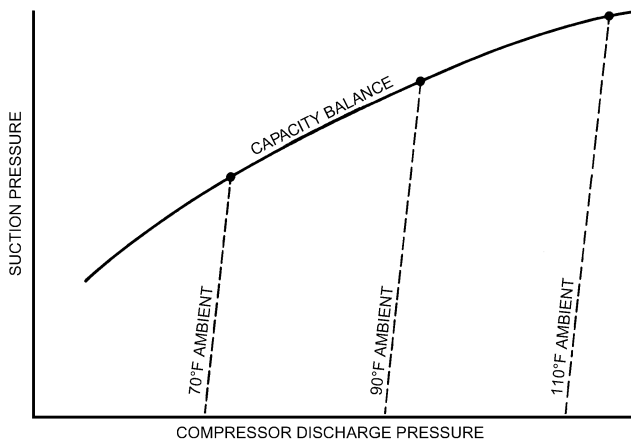
The refrigeration system should be operated through its expected range of conditions to determine power requirements and cooling capacity for any given selection and charge combination.

**Application**

**Processing and Inspection.** To prevent mechanical clogging by foreign particles, a strainer should be installed ahead of the capillary

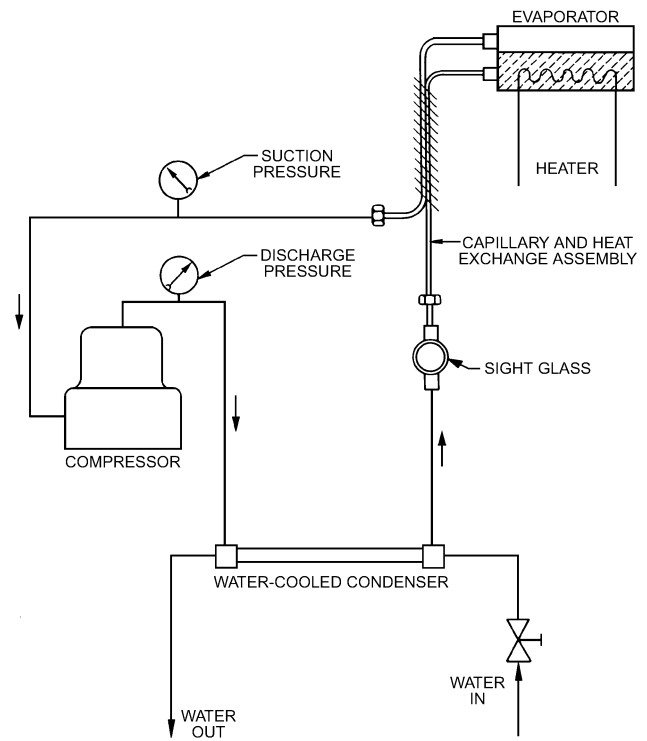


**Fig. 42 Effect of Capillary Tube Selection on Refrigerant Distribution**



Note: Operation below this curve results in a mixture of liquid and vapor entering the capillary. Operation above the capacity balance points causes liquid to back up in the condenser and elevate its pressure.

**Fig. 43 Capacity Balance Characteristic of Capillary System**



**Fig. 44 Test Setup for Determining Capacity Balance Characteristic of Compressor, Capillary, and Heat Exchanger**

tube. Also, all parts of the system must be evacuated adequately to eliminate water vapor and noncondensable gases, which may cause clogging by freezing and/or corrosion. The lubricant should be free from wax separation at the minimum operating temperature.

The interior surface of the capillary tube should be smooth and uniform in diameter. Although plug-drawn copper is more common, wire-drawn or sunk tubes are also available. Life tests should be conducted at low evaporator temperatures and high condensing temperatures to check the possibility of corrosion and plugging. Material specifications for seamless copper tube are given in ASTM *Standard B 75*. Similar information on hard-drawn copper tubes can be found in ASTM *Standard B 360*.

A procedure should be established to ensure uniform flow capacities, within reasonable tolerances, for all capillary tubes used in product manufacture. This procedure may be conducted as follows. The final capillary tube, determined from tests, is removed from the unit and given an airflow capacity rating, using the wet-test meter method described in ASHRAE *Standard 28*. Master capillary tubes are then produced, by using the wet-test meter airflow equipment, to provide the maximum and minimum flow capacities for the particular unit. The maximum-flow capillary tube has a flow capacity equal to that of the test capillary tube, plus a specified tolerance. The minimum-flow capillary tube has a flow capacity equal to that of the test capillary tube, less a specified tolerance. One sample of the maximum and minimum capillary tubes is sent to the manufacturer of capillary tubes to be used as tolerance guides for elements supplied for a particular unit. Samples are also sent to the inspection group for quality control.

**Considerations.** In selecting of a capillary tube for a specific application, practical considerations influence the length. For example, the minimum length is determined by such geometric considerations as the physical distance between the high side and low side and the length of capillary tube required for optimum heat exchange. It may also be dictated by exit velocity, noise, and the possibility of plugging with foreign materials. The maximum length may be determined primarily by cost. It is fortunate, therefore, that the flow characteristics of a capillary tube can be adjusted independently by varying either its bore or its length. Thus, it is feasible to select the most convenient length independently and then (within certain limits) select a bore to give the desired flow. An alternative procedure is to select a standard bore and then adjust the length, as required.

ASTM *Standard B 360* lists standard diameters and wall thicknesses for capillary tubes. Many nonstandard tubes are also used, resulting in nonuniform interior surfaces and variations in flow.

### ADIABATIC CAPILLARY TUBE SELECTION PROCEDURE

Wolf et al. (1995) developed refrigerant-specific rating charts to predict refrigerant flow rates through adiabatic capillary tubes. The methodology involves determining two quantities from a series of curves. They are similar to rating charts for R-12 and R-22 developed by Hopkins (1950). The two quantities necessary for the prediction of the refrigerant flow rate through the adiabatic capillary tube are a flow rate through a reference capillary tube and a flow factor  $\phi$ , which is a geometric correction factor. These two quantities are multiplied together to calculate the flow rate.

Figures 45 and 46 are rating charts for pure R-134a through adiabatic capillary tubes. Figure 45 plots the capillary tube flow rate as a function of the inlet condition and inlet pressure for a reference capillary tube geometry of 0.034 in. ID and 130 in. long. Figure 46 is a geometric correction factor. Using the desired capillary tube geometry, a flow factor  $\phi$  may be determined. This flow factor is then multiplied with the flow rate from Figure 45 to determine the predicted capillary tube flow rate. *Note:* For quality inlet conditions for R-134a, an additional correction factor of 0.95 is necessary to obtain the proper results.

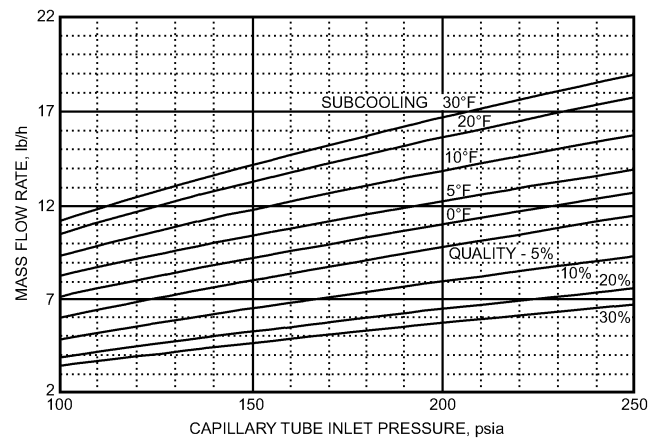


Fig. 45 Mass Flow Rate of R-134a Through Capillary Tube (Capillary tube diameter is 0.034 in. ID and length is 130 in.)

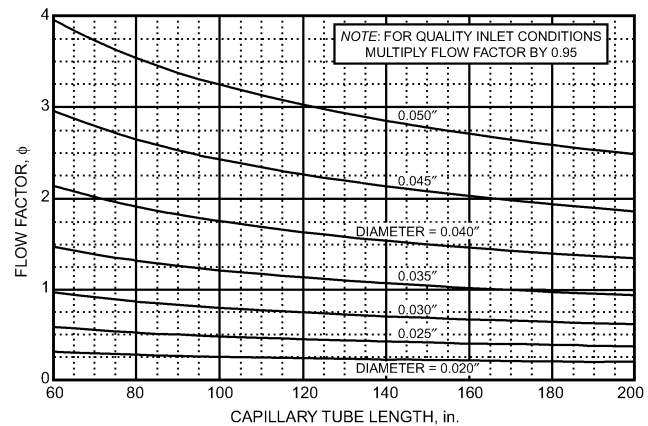


Fig. 46 Flow Rate Correction Factor  $\phi$  for R-134a

Figures 47, 48, and 49 present the rating charts for pure R-410A through adiabatic capillary tubes. The method of selection from these charts is identical to that previously presented for R-134a, except that an additional correction factor for quality inlet conditions is not used. A separate flow factor chart (Figure 49), however, is provided to determine the value of the geometric correction factor for quality inlet conditions. The same methodology using Figures 50, 51, and 52 can be used to determine the mass flow rate of R-22 through adiabatic capillary tubes. Wolf et al. (1995) developed additional rating charts for R-152a.

Wolf et al. (1995) also presented limited performance results for refrigerants R-134a, R-22, and R-410A with 1.5% lubricant. Though these results did indicate a 1% to 2% increase in the refrigerant mass flow through the capillary tubes, this magnitude was considered insignificant.

**Generalized Prediction Equations.** Based on tests with R-134a, R-22, and R-410A, Wolf et al. (1995) developed a general method for predicting refrigerant mass flow rate through a capillary tube. In this method the Buckingham  $\pi$  theorem was applied to the physical factors and fluid properties that affect capillary tube flow rate. The physical factors include capillary tube diameter and length, capillary tube inlet pressure, and the refrigerant inlet condition; the fluid properties included specific volume, viscosity, surface tension, specific heat, and latent heat of vaporization. The result of this analysis was a group of eight dimensionless  $\pi$ -terms shown in Table 3.

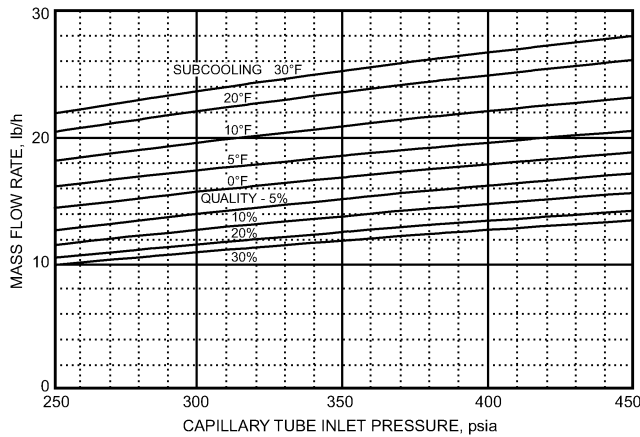


Fig. 47 Mass Flow Rate of R-410A Through Capillary Tube (Capillary tube diameter is 0.034 in. ID and length is 130 in.)

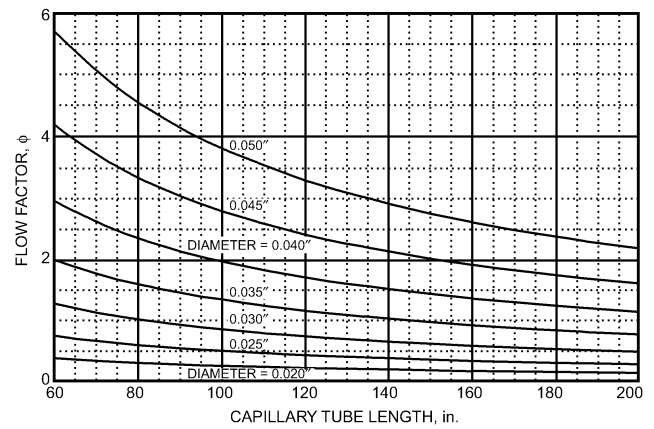


Fig. 49 Flow Rate Correction Factor  $\phi$  for R-410A for Two-Phase Condition at Capillary Tube Inlet

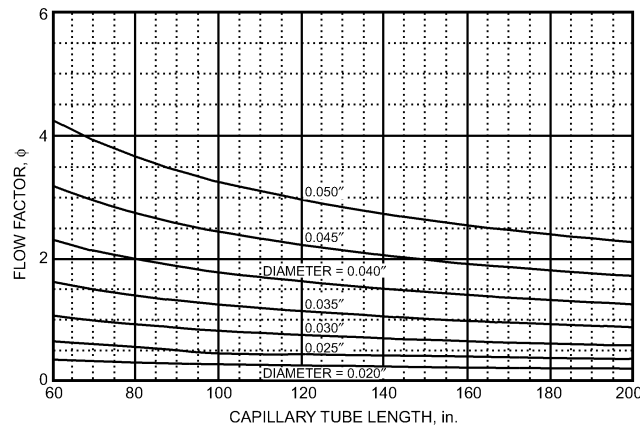


Fig. 48 Flow Rate Correction Factor  $\phi$  for R-410A for Subcooled Condition at Capillary Tube Inlet

All fluid properties for respective  $\pi$  terms, both liquid and vapor, are evaluated at the saturation state using the capillary tube inlet temperature. Separate  $\pi_5$  terms are presented for subcooled and two-phase refrigerant conditions at the capillary tube entrance. Note: The bubble formation term  $\pi_3$  is statistically insignificant and, therefore, does not appear in prediction Equations (3) and (4).

A regression analysis of the refrigerant flow rate data for the subcooled inlet results produced the following equation for subcooled inlet conditions:

$$\pi_8 = 1.8925\pi_1^{-0.484}\pi_2^{-0.824}\pi_4^{1.369}\pi_5^{0.0187}\pi_6^{0.773}\pi_7^{0.265} \quad (3)$$

where  $\pi_5 = d_c^2 c_p \Delta t_{sc} / v_f^2 \mu_f^2$  and  $2^\circ\text{F} < \Delta t_{sc} < 30^\circ\text{F}$ .

The following includes the  $\pi_5$  term that only includes the quality  $x$ .

$$\pi_8 = 187.27\pi_1^{-0.635}\pi_2^{-0.189}\pi_4^{0.645}\pi_5^{-0.163}\pi_6^{-0.213}\pi_7^{-0.483} \quad (4)$$

where  $\pi_5 = \text{quality } x$  from  $0.03 < x < 0.25$ .

Wolf et al. (1995) compared these equations to R-134a results by Dirik et al. (1994) and R-22 results by Kuehl and Goldschmidt (1990). Wolf et al. also compared experimental results with R-152a and predictions by Equations (3) and (4) and found agreement within 5%. In addition, less than 1% of the R-134a, R-22, and R-410A experimental results used by Wolf et al. to develop correlation Equations (3) and (4) were outside  $\pm 5\%$  of the flow rates predicted by the equations.

Table 3 Capillary Tube Dimensionless Parameters

$\pi$ Term	Definition	Description
$\pi_1$	$L_c / d_c$	Geometry effect
$\pi_2$	$d_c^2 h_{fg} / v_f^2 \mu_f^2$	Vaporization effect
$\pi_3$	$d_c \sigma / v_f \mu_f^2$	Bubble formation
$\pi_4$	$d_c^2 \rho_{in} / v_f \mu_f^2$	Inlet pressure
$\pi_5$ (subcooled)	$d_c^2 c_p \Delta t_{sc} / v_f^2 \mu_f^2$	Inlet condition
$\pi_5$ (quality)	$x$	Inlet condition
$\pi_6$	$v_g / v_f$	Density effect
$\pi_7$	$(\mu_f - \mu_g) / \mu_g$	Viscous effect
$\pi_8$	$\dot{m} / d_c \mu_f$	Flow rate

where

- $L_c$  = capillary tube length
- $d_c$  = capillary tube diameter
- $h_{fg}$  = latent heat or vaporization
- $v_f$  = liquid specific volume
- $v_g$  = vapor specific volume
- $\mu_f$  = liquid viscosity
- $\mu_g$  = vapor viscosity
- $\sigma$  = surface tension
- $\rho_{in}$  = capillary tube inlet pressure
- $c_p$  = liquid specific heat
- $\Delta t_{sc}$  = degree of subcooling
- $x$  = quality (decimal)
- $\dot{m}$  = mass flow rate

### Sample Calculations

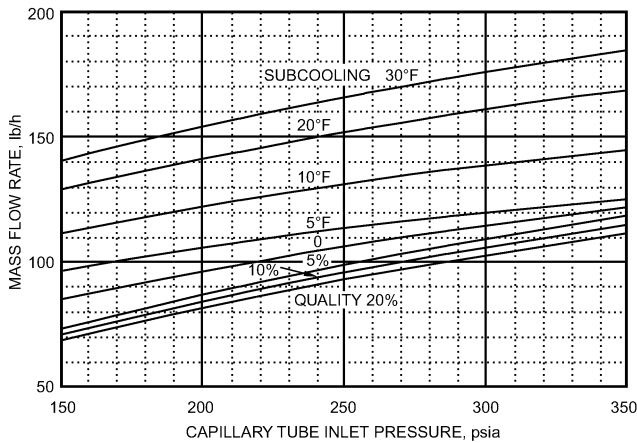
**Example 1.** Determine mass flow rate of R-134a through a capillary tube of 0.030 in. ID, 140 in. long, operating without heat exchange at 180 psia inlet pressure and 10°F subcooling.

**Solution:** From Figure 45 at 180 psia and 10°F subcooling, the flow rate of HFC-134a for a capillary tube 0.034 in. ID and 130 in. long is 13 lb/h. The flow factor  $\phi$  from Figure 46 for a capillary tube of 0.030 in. ID and 140 in. long is 0.73. The predicted R-134a flow rate is then  $13 \times 0.73 = 9.49$  lb/h.

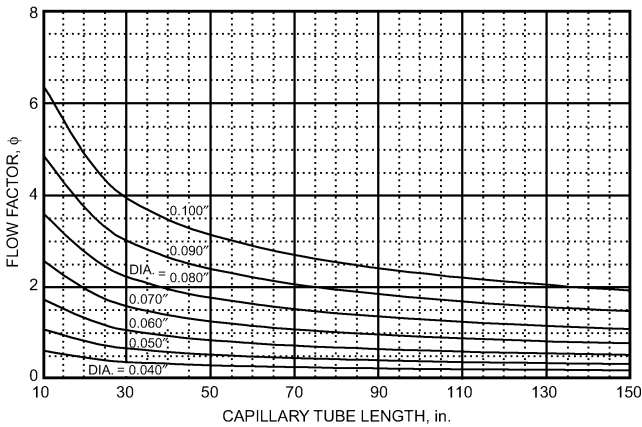
**Example 2.** Determine the mass flow rate of R-134a through a capillary tube of 0.042 in. ID, 100 in. long, operating without heat exchange at 200 psia inlet pressure and 10% vapor content at the capillary tube inlet.

**Solution:** From Figure 45, at 200 psia and 10% quality, the flow rate of R-134a for a capillary tube 0.034 in. ID and 130 in. long is 7.9 lb/h. The flow factor  $\phi$  from Figure 46 for a capillary tube of 0.042 in. ID and 100 in. long is 2.0. The predicted R-134a flow rate is then  $0.95 \times 7.9 \times 2.0 = 15.0$  lb/h, where 0.95 is the additional correction factor for R-134a quality inlet conditions.

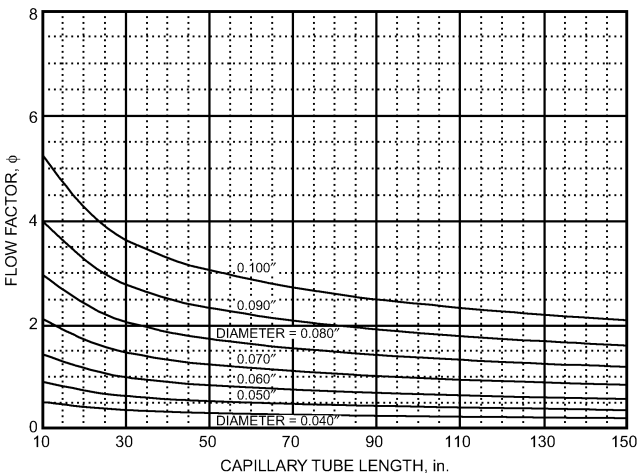
**Example 3.** Determine the mass flow rate of R-410A through a capillary tube of 0.040 in. ID, 140 in. long, operating without heat exchange, 350 psia inlet pressure, and 15°F subcooling at the capillary tube inlet.



**Fig. 50 Mass Flow Rate of R-22 Through Capillary Tube**  
(Capillary tube diameter is 0.066 in. ID and length is 60 in.)



**Fig. 51 Flow Rate Correction Factor  $\phi$  for R-22 for Subcooled Condition at Capillary Tube Inlet**



**Fig. 52 Flow Rate Correction Factor  $\phi$  for R-22 for Two-Phase Condition at Capillary Tube Inlet**

**Solution:** From [Figure 47](#), at 350 psia and 15°F subcooling, the flow rate of R-410A for a capillary tube of 0.034 in. ID and 130 in. long is 22.4 lb/h. The flow factor  $\phi$  from [Figure 48](#) for a capillary tube of 0.040 in. ID and 140 in. long is 1.5. The predicted R-410A flow rate is then  $22.4 \times 1.5 = 33.6$  lb/h.

**Example 4.** Determine the mass flow rate of R-22 through a capillary tube of 0.080 in. ID, 50 in. long, operating without heat exchange, 250 psia inlet pressure, and 5% vapor content at the capillary tube inlet.

**Solution:** From [Figure 50](#), at 250 psia and 5% quality, the flow rate of R-22 for a capillary tube of 0.066 in. ID and 60 in. long is 99.5 lb/h. The flow factor  $\phi$  from [Figure 52](#) for a capillary tube of 0.080 in. ID and 50 in. long is 1.75. The predicted R-22 flow rate is then  $99.5 \times 1.75 = 174.1$  lb/h.

### CAPILLARY TUBE-SUCTION LINE HEAT EXCHANGER SELECTION PROCEDURE

In certain refrigeration applications, a portion of the capillary tube is soldered to or in contact with the suction line such that heat exchange occurs between the warm fluid in the capillary tube and the relatively cooler refrigerant vapor in the suction line. The addition of the capillary tube-suction line heat exchanger to the refrigeration cycle can have several advantages. For some refrigerants, the addition results in an increase in the system's COP and volumetric capacity. Domanski et al. (1994) reported that this is not the case for all refrigerants and that some refrigeration systems may see a decrease in COP depending upon the particular refrigerant in the system. In typical household refrigerators, the suction line is soldered to the capillary tube so that the heat exchanged with the suction line will prevent condensation on the surface of the suction line during operation. The capillary tube-suction line heat exchanger also ensures that superheated refrigerant vapor exists at the compressor inlet and eliminates the possibility of liquid refrigerant returning to the compressor.

When a suction line heat exchanger is used, the excess capillary length may be coiled and located at either end of the heat exchanger. Although more heat is exchanged with the excess coiled at the evaporator, system stability may be enhanced with the excess coiled at the condenser. Forming of coils and bends should be done carefully to avoid local restrictions. The effect of forming on the restriction should be considered when specifying the capillary.

### Capillary Tube Selection

Wolf and Pate (2001) developed refrigerant-specific rating charts to predict refrigerant flow rates through capillary tube-suction line heat exchangers. The methodology involves determining four quantities (three for quality inlet conditions) from a series of curves and multiplying the results together to obtain the flow rate prediction. The calculation procedure is very similar to the adiabatic capillary tube selection process with the exception of the additional flow rate factors. [Figures 53 through 57](#) are the rating charts for pure R-134a through capillary tube-suction line heat exchangers. [Figure 53](#) plots the refrigerant flow rate as a function of capillary tube inlet pressure and inlet condition for a reference heat exchanger configuration ( $D_c = 0.034$  in.,  $L_c = 130$  in., and  $L_{hx} = 60$  in.). The thermodynamic state of the refrigerant vapor at the suction line inlet to the heat exchanger has also been fixed (24 psia and 20°F superheat). [Figure 54](#) plots a flow rate correction factor  $\phi_1$  as a function of the capillary tube diameter and length for subcooled inlet conditions at the capillary tube inlet. [Figure 55](#) plots a second flow rate correction factor  $\phi_2$  as a function of suction line inlet pressure and superheat level at the inlet to the suction line for subcooled inlet conditions at the capillary tube inlet. [Figure 56](#) plots a third flow rate correction factor  $\phi_3$  as a function of heat exchange length for subcooled inlet conditions at the capillary tube inlet. [Figure 57](#) is the capillary tube geometry correction factor for quality inlet conditions at the capillary tube inlet, and [Figure 58](#) is the suction line condition correction factor for quality inlet conditions at the capillary tube inlet. There is no  $\phi_3$  correc-

tion factor for heat exchange length for quality inlet conditions. In general, heat exchange length delays the onset of vaporization of the refrigerant inside the capillary tube. However, without recondensation in the capillary tube as a result of the heat exchange effect, there is no vaporization for two-phase conditions at the capillary tube inlet.

To predict refrigerant mass flow rate for other conditions and geometries, multiply the necessary correction factors by the refer-

ence flow rate from [Figure 53](#). Additional design variables examined by Wolf and Pate (2001) were the adiabatic upstream entrance length and inner diameter of the suction line tubing. For adiabatic entrance lengths from 6 to 24 in., there was no observed effect. There was also no effect observed that could be attributed to the inner diameter of the suction line. Because of their lack of effect, these two design variables are not included when predicting refrigerant flow rate.

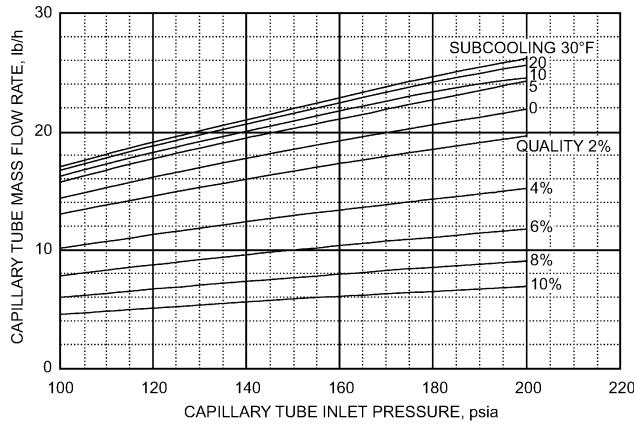


Fig. 53 Inlet Condition Rating Chart for R-134a

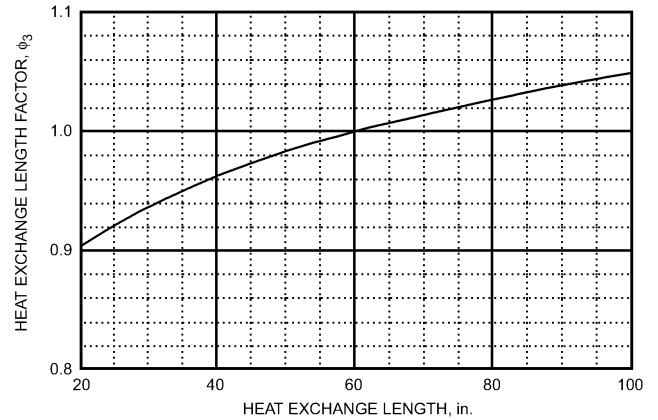


Fig. 56 Heat Exchange Length Correction Factor for R-134a Subcooled Inlet Conditions

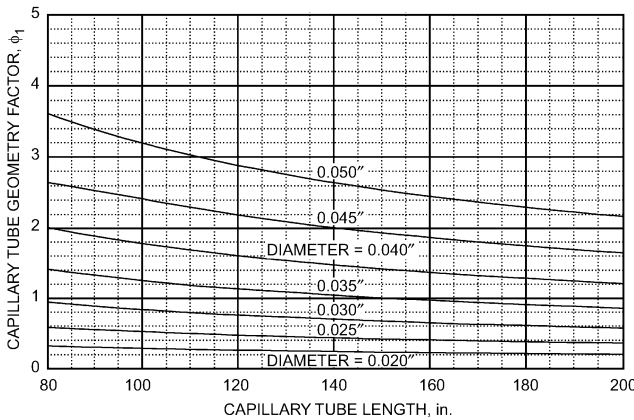


Fig. 54 Capillary Tube Geometry Correction Factor for Subcooled R-134a Inlet Conditions

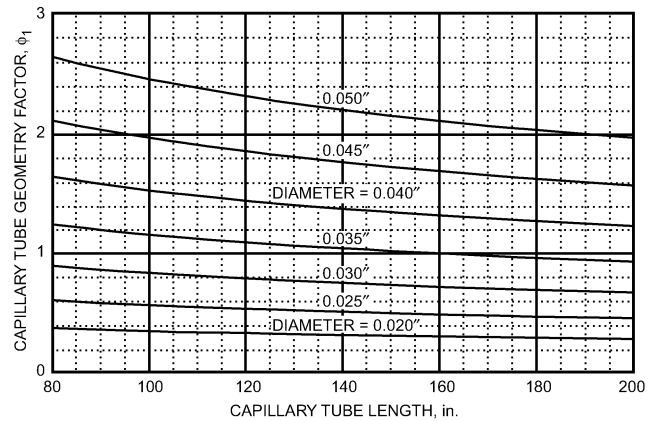


Fig. 57 Capillary Tube Geometry Correction Factor for R-134a Quality Inlet Conditions

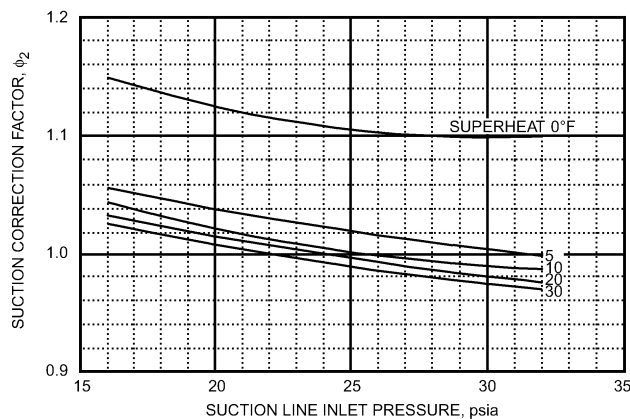


Fig. 55 Suction Line Condition Correction Factor for R-134a Subcooled Inlet Conditions

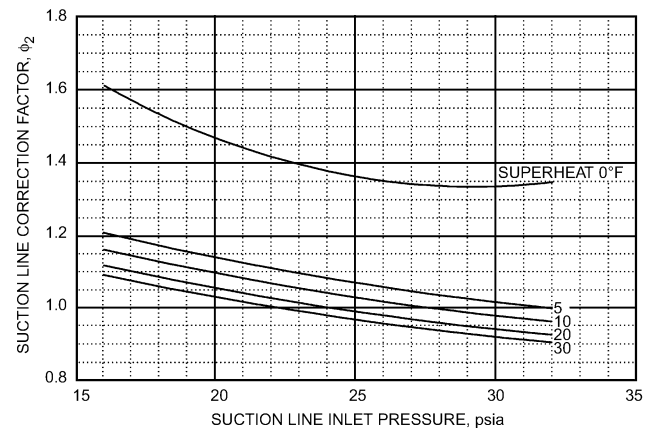


Fig. 58 Suction Line Condition Correction Factor for R-134a Quality Inlet Conditions

**Table 4 Capillary Tube–Suction Line Heat Exchanger Dimensionless Parameters**

$\pi$ Parameter	Definition	Description
$\pi_1$	$L_c/D_c$	Geometry effect
$\pi_2$	$L_i/D_c$	Geometry effect
$\pi_3$	$L_{hx}/D_c$	Geometry effect
$\pi_4$	$D_s/D_c$	Geometry effect
$\pi_5$	$P_{capin} D_c^2 / \mu_{fc}^2 v_{fc}$	Inlet pressure
$\pi_6$	$P_{suctin} D_c^2 / \mu_{fc}^2 v_{fc}$	Inlet pressure
$\pi_7$ (subcooled)	$\Delta T_{sc} C_{pfc} D_c^2 / \mu_{fc}^2 v_{fc}^2$	Inlet condition
$\pi_7$ (quality)	$1 - x$	Inlet condition
$\pi_8$	$\Delta T_{sh} C_{pfc} D_c^2 / \mu_{fc}^2 v_{fc}^2$	Inlet condition
$\pi_9$	$\dot{m} / D_c \mu_{fc}$	Flow rate
$\pi_{10}$	$v_{gc} / v_{fc}$	Density effect
$\pi_{11}$	$(\mu_{fc} - \mu_{gc}) / \mu_{fc}$	Viscous effect
$\pi_{12}$	$h_{fgc} D_c^2 / \mu_{fc}^2 v_{fc}^2$	Vaporization effect
$\pi_{13}$	$\mu_{gs} / \mu_{fc}$	Viscous effect
$\pi_{14}$	$v_{gs} / v_{fc}$	Density effect
$\pi_{15}$	$C_{pgs} / C_{pfc}$	Specific heat effect

where

$D_c$ = capillary tube inside diameter (0.026 in. to 0.042 in.)	$\mu_{gs}$ = suction inlet vapor viscosity
$L_c$ = capillary tube length (80 in. to 180 in.)	$v_{fc}$ = capillary inlet liquid specific volume
$L_{hx}$ = heat exchange length (20 in. to 100 in.)	$v_{gc}$ = capillary inlet vapor specific volume
$D_s$ = suction line inside diameter (0.194 in. to 0.319 in.)	$v_{gs}$ = suction inlet vapor specific volume
$L_i$ = adiabatic entrance length (6 in. to 24 in.)	$C_{pfc}$ = capillary inlet liquid specific heat
$P_{capin}$ = capillary tube inlet pressure	$C_{pgs}$ = suction inlet vapor specific heat
$P_{suctin}$ = suction line inlet pressure	$h_{fgc}$ = capillary inlet latent heat of vaporization
$\Delta T_{sc}$ = capillary tube inlet subcool level (2°F to 30°F)	$\dot{m}$ = mass flow rate
$x$ = quality (2% to 10%)	
$\Delta T_{sh}$ = suction line inlet superheat (6°F to 40°F)	
$\mu_{fc}$ = capillary inlet liquid viscosity	
$\mu_{gc}$ = capillary inlet vapor viscosity	

**Generalized Prediction Equations**

Based on tests with R-134a, R-22, R-410A, and R-600a, Wolf and Pate (2001) developed a general method for predicting refrigerant mass flow rate through a capillary tube–suction line heat exchanger. In this method, the Buckingham  $\pi$  theorem was applied to the physical factors and fluid properties that affect capillary tube flow rate through a capillary tube–suction line heat exchanger. The physical factors included capillary tube diameter, capillary tube length, suction line diameter, heat exchange length, adiabatic entrance length of the capillary tube, capillary tube inlet pressure and condition and suction line inlet pressure and condition. The fluid properties included specific volume, viscosity, specific heat, and latent heat of vaporization. The result of this analysis was a group of 15 dimensionless  $\pi$  parameters, shown in Table 4.

All fluid properties for the respective  $\pi$  terms are evaluated at the capillary tube inlet temperature. Separate  $\pi_7$  terms are presented for subcooled and quality inlet conditions to the capillary tube. The  $\pi$  terms in Table 4 that do not appear in Equations (5) and (6) were statistically insignificant and were not included in the final correlations.

A regression analysis of the refrigerant flow rate data for subcooled inlet conditions produced the following equation:

$$\pi_9 = 0.07602\pi_1^{-0.4583}\pi_3^{0.07751}\pi_5^{0.7342}\pi_6^{-0.1204}\pi_7^{0.03774}\pi_8^{-0.04085}\pi_{11}^{0.1768} \quad (5)$$

where  $\pi_7 = \Delta T_{sc} C_{pfc} D_c^2 / \mu_{fc}^2 v_{fc}^2$  and  $2^\circ\text{F} < \Delta T_{sc} < 30^\circ\text{F}$ .

Equation (6) is valid for quality inlet conditions and contains the quality inlet term  $\pi_7 = 1 - x$ .

$$\pi_9 = 0.01960\pi_1^{-0.3127}\pi_5^{1.059}\pi_6^{-0.3662}\pi_7^{4.759}\pi_8^{-0.04965} \quad (6)$$

where  $x$  = quality (decimal) from  $0.02 < x < 0.10$ .

Wolf and Pate (2001) compared these equations to R-152a test results as well as published R-134a, R-152a, and R-12 data. Excellent agreement ( $\pm 10\%$ ) was observed in nearly all cases. The only exception was the R-134a results by Dirik et al. (1994). Equation (5) overpredicted these results by an average of 45%. However, the adiabatic entrance length used was approximately 134 in., indicating that very long adiabatic entrance lengths may decrease refrigerant flow rates.

For further information on other refrigerants, please see the Bibliography.

**Sample Calculations**

**Example 5.** Determine the mass flow rate of R-134a through a capillary tube of 0.040 in. ID and 160 in. long operating with heat exchange at 160 psia capillary inlet pressure and 20°F subcooling. The heat exchange length is 70 in., and the suction line inlet conditions are 16 psia and 20°F superheat.

**Solution:** From Figure 53, at 160 psia and 20°F subcooling, the flow rate for a capillary tube 0.034 in. ID and 130 in. long is 22.5 lb/h. The capillary tube geometry correction factor from Figure 54 is 1.3. The suction line inlet correction factor from Figure 55 is 1.033 and the heat exchange length factor from Figure 56 is 1.01. The predicted mass flow rate is then  $22.5 \times 1.37 \times 1.033 \times 1.01 = 32.2$  lb/h.

**Example 6.** Determine the mass flow rate of R-134a through a capillary tube of 0.030 in. ID and 80 in. long operating with heat exchange at 140 psia capillary inlet pressure and 6% quality. The heat exchange length is 55 in., and the suction line inlet conditions are 20 psia and 10°F superheat.

**Solution:** From Figure 53, at 140 psia and 6% quality, the flow rate for a capillary tube 0.034 in. ID and 130 in. long is 9.5 lb/h. The capillary tube geometry correction factor from Figure 57 is 0.90. The suction line inlet correction factor from Figure 58 is 1.09. There is no heat exchange length correction factor for quality inlet conditions, so the predicted mass flow rate is then  $9.5 \times 0.90 \times 1.09 = 9.3$  lb/h.

**SHORT-TUBE RESTRICTORS**

**Application**

Short-tube restrictors are widely used in residential air conditioners and heat pumps. They offer the advantages of low cost, high reliability, ease of inspection and replacement, and potential elimination of check valves in the design of a heat pump. Due to their pressure-equalizing characteristics, short-tube restrictors allow the use of a low-starting-torque compressor motor.

Short-tube restrictors, as used in residential systems, are typically 3/8 to 1/2 in. in length, with a length-to-diameter ( $L/D$ ) ratio greater than 3 and less than 20. Short-tube restrictors are also called **plug orifices** or **orifices**, although the latter is reserved for restrictors having an  $L/D$  ratio less than 3. Capillary tubes have an  $L/D$  ratio much greater than 20.

An **orifice tube**, a type of short-tube restrictor, is commonly used in automotive air conditioners. The  $L/D$  ratio of an orifice tube falls between that of a capillary tube and a short-tube restrictor. Most automotive applications use orifice tubes with  $L/D$  ratios between 21 and 35 and inside diameters from 0.04 to 0.08 in. An orifice tube allows the evaporator to operate in a flooded condition, which improves performance. To prevent liquid from flooding the compressor, an accumulator/dehydrator is installed to separate liquid from vapor and to meter a small amount of lubricant-rich refrigerant to the compressor. However, the accumulator/dehydrator does cause a pressure drop penalty on the suction side.

There are two basic designs for short-tube restrictors: stationary and movable. Movable short-tube restrictors consist of a piston that moves within its housing (Figure 59). A movable short-tube restrictor restricts refrigerant flow in one direction. In the opposite direction, the refrigerant pushes the restrictor off its seat, opening a larger

area for the flow. The stationary design is used in units that cool only; movable short-tube restrictors are used in heat pumps that require different flow restrictions for cooling and heating modes. Two movable short-tube restrictors, installed in series and faced in opposite directions, eliminate the need for check valves, which would be needed for capillary tubes and thermostatic expansion valves.

The refrigerant mass flow rate through a short-tube restrictor depends strongly on upstream subcooling and upstream pressure. For a given inlet pressure, inlet subcooling, and downstream pressure below the saturation pressure corresponding to the inlet temperature, the flow has a very weak dependence on the downstream pressure, indicating a nearly choked flow. This flow dependence is shown in Figure 60, and represents R-22 test data obtained on a 0.5 in. long, laboratory-made short-tube restrictor at three different downstream pressures and the same upstream pressure.

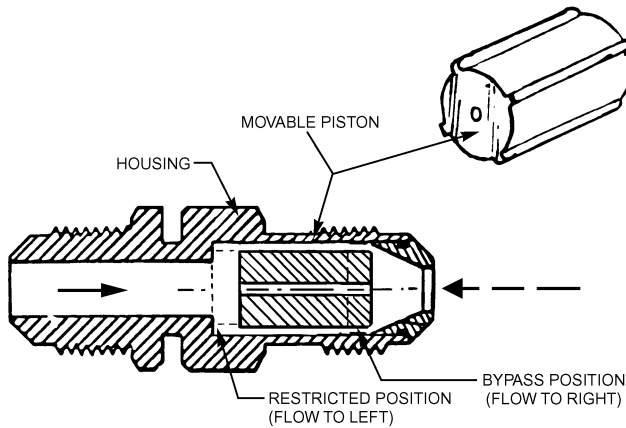


Fig. 59 Schematic of Movable Short-Tube Restrictor

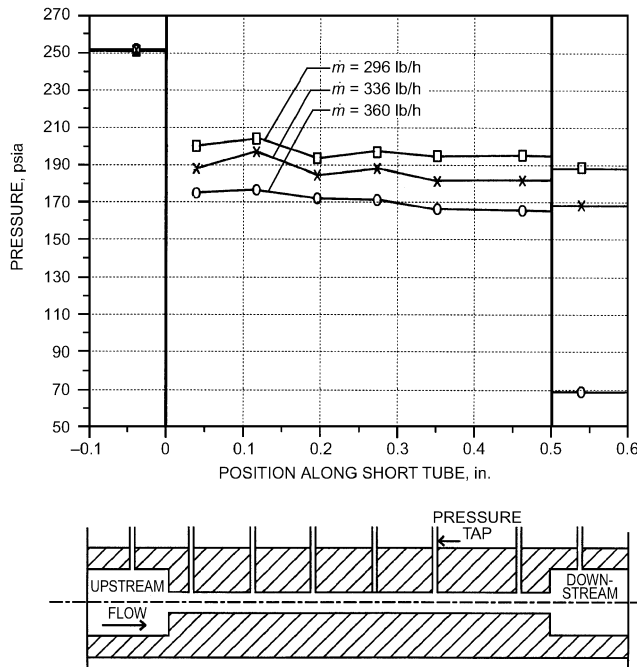


Fig. 60 R-22 Pressure Profile at Various Downstream Pressures with Constant Upstream Conditions:  
 $L = 0.5 \text{ in.}, D = 0.053 \text{ in.}, \text{Subcooling } 25^\circ\text{F}$   
 (Adapted from Aaron and Domanski 1990)

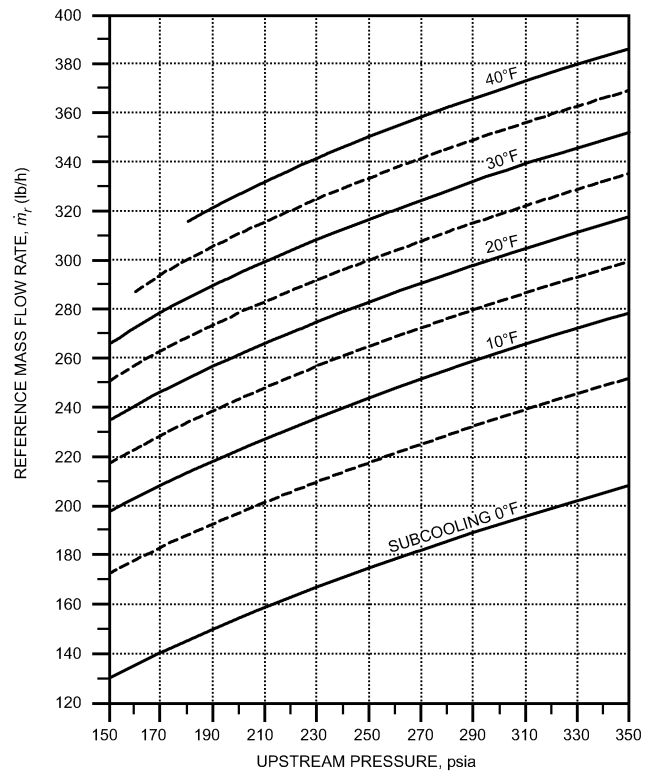


Fig. 61 R-22 Mass Flow Rate vs. Condenser Pressure for Reference Short Tube:  
 $L = 0.5 \text{ in.}, D = 0.053 \text{ in.}, \text{Sharp-Edged}$   
 (Adapted from Aaron and Domanski 1990)

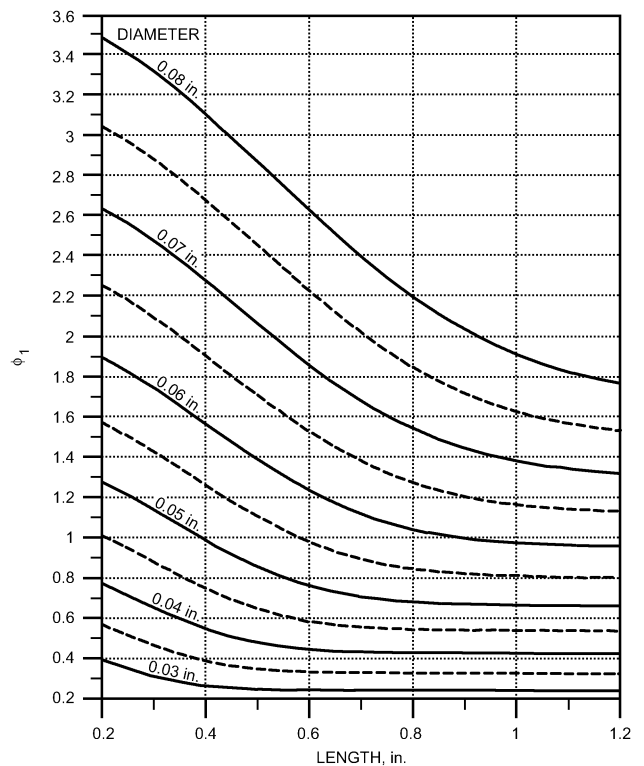
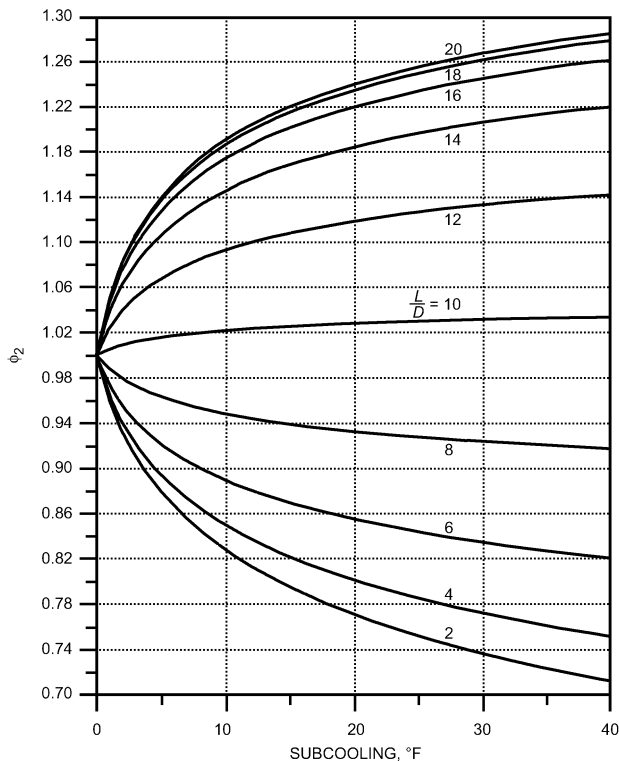
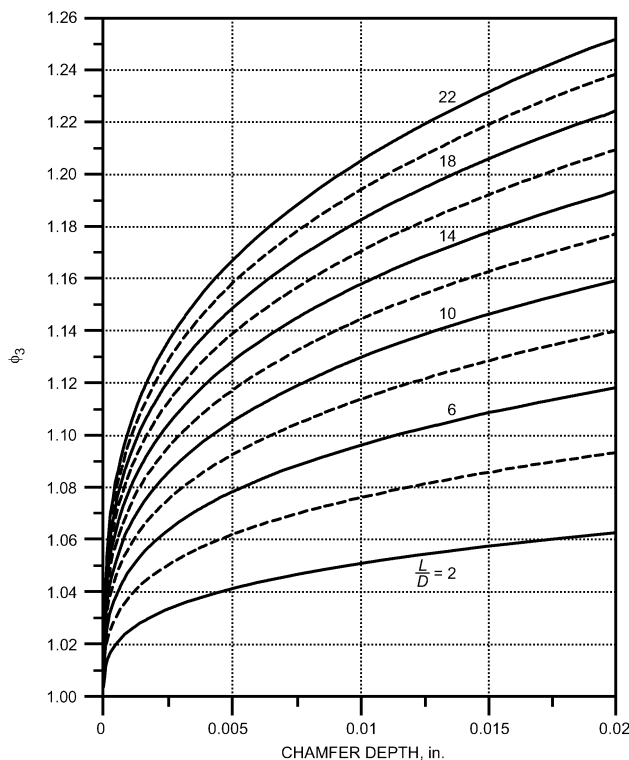


Fig. 62 Correction Factor for Short-Tube Geometry (R-22)  
 (Adapted from Aaron and Domanski 1990)



**Fig. 63 Correction Factor for  $L/D$  vs. Subcooling (R-22)**  
(Adapted from Aaron and Domanski 1990)



**Fig. 64 Correction Factor for Inlet Chamfering (R-22)**  
(Adapted from Aaron and Domanski 1990)

A significant drop in downstream pressure from approximately 170 to 70 psia produces a smaller increase in the mass flow rate than does a modest change of downstream pressure from 190 to 170 psia. The pressure drops only slightly along the length of the short-tube restrictor. The large pressure drop at the entrance is due to the rapid fluid acceleration and the inlet losses. The large pressure drop in the exit plane, typical for heat pump operating conditions and represented in Figure 60 by the bottom pressure line, indicates that choked flow has nearly occurred.

Among geometric parameters, the short-tube restrictor diameter has the strongest influence on mass flow rate. Chamfering the inlet of the short-tube restrictor may increase the mass flow rate by as much as 25%, depending on the  $L/D$  ratio and chamfer depth. Chamfering the exit causes no appreciable change in mass flow rate.

Although refrigerant flow inside a short tube is different from flow inside a capillary tube, choked flow is common for both, making both types of tubes suitable as metering devices. Systems equipped with short-tube restrictors, as with capillary tubes, must be precisely charged with the proper amount of refrigerant. Inherently, a short-tube restrictor does not control as well over a wide range of operating conditions as does a thermostatic expansion valve. However, its performance is generally good in a properly charged system.

**Selection**

Figures 61 through 64, from Aaron and Domanski (1990), can be used for a preliminary evaluation of the mass flow rate of R-22 at a given inlet pressure and subcooling in air-conditioning and heat pump applications (i.e., applications in which the downstream pressure is below the saturation pressure of refrigerant at the inlet). The method requires the determination of mass flow rate for the reference short tube from Figure 61 and modifying the reference flow rate with multipliers that account for the short-tube geometry according to the equation

$$\dot{m} = \dot{m}_r \phi_1 \phi_2 \phi_3 \tag{7}$$

where

- $\dot{m}$  = mass flow rate for the short tube
- $\dot{m}_r$  = mass flow rate for the reference short tube from Figure 61
- $\phi_1$  = correction factor for tube geometry from Figure 62
- $\phi_2$  = correction factor for  $L/D$  vs. subcooling from Figure 63
- $\phi_3$  = correction factor for chamfered inlet from Figure 64

Aaron and Domanski (1990) also provide a more accurate correlation than the graphical method. Neglecting downstream pressure on the graphs may introduce an error in the prediction as compared to the correlation results; however, this discrepancy should not exceed 3% due to the choked-flow condition at the tube exit. *Note:* The lines for 0 and 40°F subcooling in Figure 61 were obtained by extrapolation beyond the test data and may carry a large error.

Additional research has been done to add several other refrigerants' capacity ratings to this section. However, only data for R-410A and R-407c have been published in ASHRAE Transactions (Payne and O'Neal 1998, 1999).

**Example 7.** Determine the mass flow rate of R-22 through a short-tube restrictor 0.375 in. long, of 0.06 in. ID, and chamfered 0.01 in. deep at an angle of 45°. The inlet pressure is 240 psia, and subcooling is 10°F.

**Solution:** From Figure 61, for 240 psia and 10°F subcooling, the flow rate for the reference short tube is 240 lb/h. The value for  $\phi_1$  from Figure 62 is 1.62. The value for  $\phi_2$  from Figure 63 for 10°F subcooling and  $L/D = 0.375/0.06 = 6.25$  is 0.895. The value of  $\phi_3$  from Figure 64 for  $L/D = 6.25$  and a chamfer depth of 0.01 in. is 1.098. Thus, the predicted mass flow rate through the restrictor is  $240 \times 1.62 \times 0.895 \times 1.098 = 382$  lb/h.

## REFERENCES

- Aaron, D.A. and P.A. Domanski. 1990. Experimentation, analysis, and correlation of Refrigerant-22 flow through short tube restrictors. *ASHRAE Transactions* 96(1):729-742.
- API. 1993. *Sizing, selection, and installation of pressure-relieving devices in refineries, Part I—Sizing and selection*, 6th ed. Recommended Practice RP 520 PT I 1993. American Petroleum Institute, Washington, D.C.
- API. 1994. *Sizing, selection, and installation of pressure-relieving devices in refineries, Part II—Installation*, 4th ed. Recommended Practice RP-520 PT II 1994. American Petroleum Institute, Washington, D.C.
- ARI. 1994. Thermostatic refrigerant expansion valves. *Standard 750*. Air-Conditioning and Refrigeration Institute, Arlington, VA.
- ASHRAE. 1994. Safety code for mechanical refrigeration. *Standard 15-1994*.
- ASHRAE. 1996. Method of testing flow capacity of refrigerant capillary tubes. *Standard 28-1996*.
- ASHRAE. 1998. Method of testing capacity of thermostatic refrigerant expansion valves. *Standard 17-1998*.
- ASTM. 1995. Standard specification for hand-drawn copper capillary tube for restrictor applications. *Standard B 360-1995*. American Society for Testing and Materials, West Conshohocken, PA.
- ASTM. 1999. Standard specification for seamless copper tube. *Standard B 75-1999*. American Society for Testing and Materials, West Conshohocken, PA.
- Bolstad, M.M. and R.C. Jordan. 1948. Theory and use of the capillary tube expansion device. *Refrigerating Engineering* (December):519.
- Dirik, E., C. Inan, and M.Y. Tanes. 1994. Numerical and experimental studies on adiabatic and non-adiabatic capillary tubes with HFC-134a. *Proceeding International Refrigeration Conference*, Purdue University, West Lafayette, IN.
- Domanski, P.A., D.A. Didion, and J.P. Doyle. 1994. Evaluation of suction line-liquid line heat exchange in the refrigeration cycle. *International Journal of Refrigeration* 17(7):487-493.
- Hopkins, N.E. 1950. Rating the restrictor tube. *Refrigerating Engineering* (November):1087.
- Kuehl, S.J. and V.W. Goldschmidt. 1990. Steady flow of R-22 through capillary tubes: Test data. *ASHRAE Transactions* 96(1):719-728.
- Kuehl, S.J. and V.W. Goldschmidt. 1991. Modeling of steady flows of R-22 through capillary tubes. *ASHRAE Transactions* 97(1):139-148.
- Li, R.Y., S. Lin, Z.Y. Chen, and Z.H. Chen. 1990. Metastable flow of R-12 through capillary tubes. *International Journal of Refrigeration* 13(3):181-186.
- Mikol, E.P. 1963. Adiabatic single and two-phase flow in small bore tubes. *ASHRAE Journal* 5(11):75-86.
- Payne, W.V. and D.L. O'Neal 1998. Mass flow characteristics of R-407c through short tube orifices. *ASHRAE Transactions* 104(1).
- Payne, W.V. and D.L. O'Neal 1999. Multiphase flow of Refrigerant 410A through short tube orifices. *ASHRAE Transactions* 105(2).
- Whitesel, H.A. 1957a. Capillary two-phase flow. *Refrigerating Engineering* (April):42.
- Whitesel, H.A. 1957b. Capillary two-phase flow—Part II. *Refrigerating Engineering* (September):35.
- Wolf, D.A., R.R. Bittle, and M.B. Pate. 1995. Adiabatic capillary tube performance with alternative refrigerants. *Final Report ASHRAE 762-RP*.
- Wolf, D.A. and M.B. Pate. 2001. Capillary tube—Suction line heat exchanger performance with alternative refrigerants. *Final Report ASHRAE 948-RP*.

## BIBLIOGRAPHY

- Bittle, R.R. and M.B. Pate. 1996. A theoretical model for predicting adiabatic capillary tube performance with alternative refrigerants. *ASHRAE Transactions* 102(2):52-64.
- Bittle, R.R., D.A. Wolf, and M.B. Pate. 1998. A generalized performance prediction method for adiabatic capillary tubes. *HVAC&R Research Journal* 4(1):27-43.
- Kuehl, S.J. and V.W. Goldschmidt. 1990. Transient response of fixed area expansion devices. *ASHRAE Transactions* 96(1):743-750.
- Marcy, G.P. 1949. Pressure drop with change of phase in a capillary tube. *Refrigerating Engineering* (January):53.
- Pate, M.B. and D.R. Tree. 1987. An analysis of choked flow conditions in a capillary tube—suction line heat exchanger. *ASHRAE Transactions* 93(1):368-380.
- Schulz, U. 1985. State of the art: The capillary tube for, and in, vapor compression systems. *ASHRAE Transactions* 91(1):92-105.
- Wijaya, H. 1991. An experimental evaluation of adiabatic capillary tube performance for HFC-134a and CFC-12, pp. 474-483. *Proceedings of the International CFC and Halon Alternatives Conference*. Alliance of Responsible CFC Policy, Arlington, VA.