

APPLIED HEAT PUMP AND HEAT RECOVERY SYSTEMS

Terminology	8.1	Industrial Process Heat Pumps	8.8
APPLIED HEAT PUMP SYSTEMS	8.1	APPLIED HEAT RECOVERY	
Heat Pump Cycles	8.1	SYSTEMS	8.15
Heat Sources and Sinks	8.2	Waste Heat Recovery	8.15
Types of Heat Pumps	8.4	Water Loop Heat Pump Systems	8.16
Heat Pump Components	8.6	Balanced Heat Recovery Systems	8.20

TERMINOLOGY

BALANCED heat recovery. Occurs when internal heat gain equals recovered heat and no external heat is introduced to the conditioned space. Maintaining balance may require raising the temperature of the recovered heat.

Break-even temperature. The outdoor temperature at which the total heat losses from conditioned spaces equal the internally generated heat gains.

Changeover temperature. The outdoor temperature the designer selects as the point of changeover from cooling to heating by the HVAC system.

External heat. Heat generated from sources outside the conditioned area. This heat from gas, oil, steam, electricity, or solar sources supplements internal heat and internal process heat sources. Recovered internal heat can reduce the demand for external heat.

Internal heat. The total passive heat generated within the conditioned space. It includes heat generated by lighting, computers, business machines, occupants, and mechanical and electrical equipment such as fans, pumps, compressors, and transformers.

Internal process heat. Heat from industrial activities and sources such as wastewater, boiler flue gas, coolants, exhaust air, and some waste materials. This heat is normally wasted unless equipment is included to extract it for further use.

Pinch technology. An energy analysis tool that uses vector analysis to evaluate all heating and cooling utilities in a process. Composite curves created by adding the vectors allow identification of a “pinch” point, which is the best thermal location for a heat pump.

Recovered (or reclaimed) heat. Comes from internal heat sources. It is used for space heating, domestic or service water heating, air reheat in air conditioning, process heating in industrial applications, or other similar purposes. Recovered heat may be stored for later use.

Stored heat. Heat from external or recovered heat sources that is held in reserve for later use.

Usable temperature. The temperature or range of temperatures at which heat energy can be absorbed, rejected, or stored for use within the system.

Waste heat. Heat rejected from the building (or process) because its temperature is too low for economical recovery or direct use.

APPLIED HEAT PUMP SYSTEMS

A heat pump extracts heat from a source and transfers it to a sink at a higher temperature. According to this definition, all pieces of refrigeration equipment, including air conditioners and chillers with refrigeration cycles, are heat pumps. In engineering, however, the term **heat pump** is generally reserved for equipment that heats for beneficial purposes, rather than that which removes heat for cooling only. Dual-mode heat pumps alternately provide heating or cooling.

The preparation of this chapter is assigned to TC 9.4, Applied Heat Pump/Heat Recovery Systems.

Heat reclaim heat pumps provide heating only, or simultaneous heating and cooling. An applied heat pump requires competent field engineering for the specific application, in contrast to the use of a manufacturer-designed unitary product. Applied heat pumps include built-up heat pumps (field- or custom-assembled from components) and industrial process heat pumps. Most modern heat pumps use a vapor compression (modified Rankine) cycle or an absorption cycle. Any of the other refrigeration cycles discussed in [Chapter 1 of the ASHRAE Handbook—Fundamentals](#) are also suitable. Although most heat pump compressors are powered by electric motors, limited use is also made of engine and turbine drives. Applied heat pump systems are most commonly used for heating and cooling buildings, but they are gaining popularity for efficient domestic and service water heating, pool heating, and industrial process heating.

Applied heat pumps having capacities ranging from 24,000 to 150,000,000 Btu/h operate in many facilities. Some of these machines are capable of output water temperatures up to 220°F and steam pressures up to 60 psig.

Compressors in large systems vary from one or more reciprocating or screw types to staged centrifugal types. A single or central system is often used, but in some instances, multiple heat pump systems are used to facilitate zoning. Heat sources include the ground, well water, surface water, gray water, solar energy, the air, and internal building heat. Compression can be single-stage or multistage. Frequently, heating and cooling are supplied simultaneously to separate zones.

Decentralized systems with water loop heat pumps are common, using multiple water-source heat pumps connected to a common circulating water loop. They can also include ground coupling, heat rejectors (cooling towers and dry coolers), supplementary heaters (boilers and steam heat exchangers), loop reclaim heat pumps, solar collection devices, and thermal storage. The initial cost is relatively low, and building reconfiguration is easily accommodated.

Community and district heating and cooling systems based on both centralized and distributed heat pump systems are feasible.

HEAT PUMP CYCLES

Several types of applied heat pumps (both open and closed cycle) are available; some reverse their cycles to deliver both heating and cooling in HVAC systems, and others are for heating only in HVAC and industrial process applications. The following are the four basic types of heat pump cycles:

1. **Closed vapor compression cycle** ([Figure 1](#)). This is the most common type used in both HVAC and industrial processes. It employs a conventional, separate refrigeration cycle that may be single-stage, compound, multistage, or cascade.
2. **Mechanical vapor recompression (MVR) cycle with heat exchanger** ([Figure 2](#)). Process vapor is compressed to a temperature and pressure sufficient for reuse directly in a process. Energy consumption is minimal, because temperatures are optimum for the

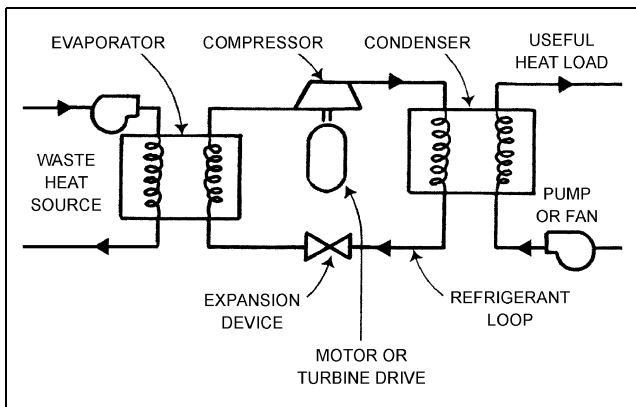

Fig. 1 Closed Vapor Compression Cycle

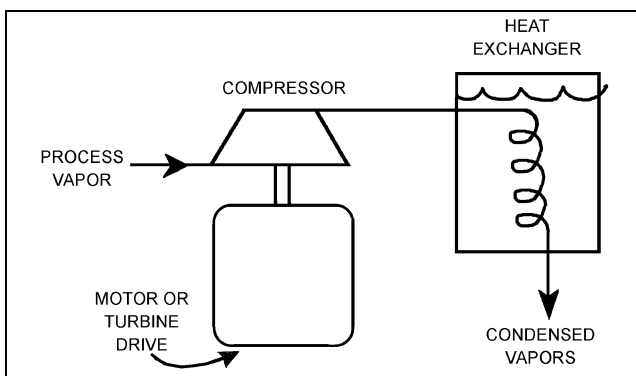

Fig. 2 Mechanical Vapor Recompression Cycle with Heat Exchanger

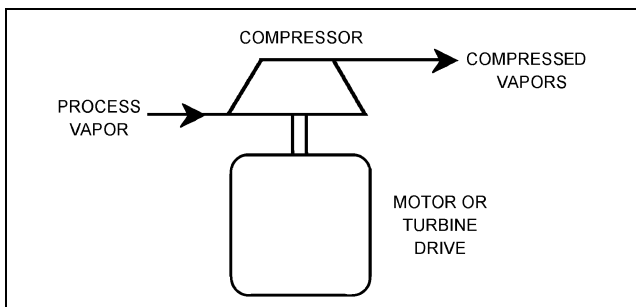

Fig. 3 Open Vapor Recompression Cycle

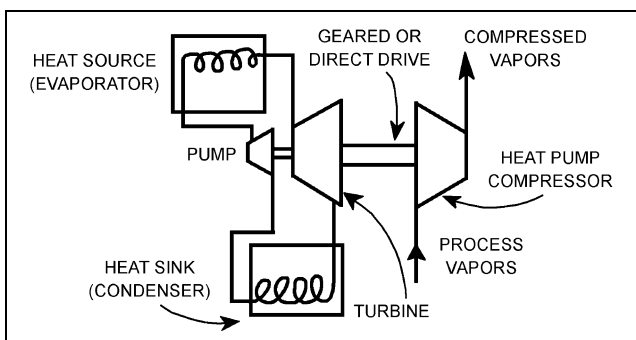

Fig. 4 Heat-Driven Rankine Cycle

process. Typical applications for this cycle include evaporators (concentrators) and distillation columns.

3. **Open vapor recompression cycle** (Figure 3). A typical application for this cycle is in an industrial plant with a series of steam pressure levels and an excess of steam at a lower-than-desired pressure. The heat is pumped to a higher pressure by compressing the lower pressure steam.
4. **Heat-driven Rankine cycle** (Figure 4). This cycle is useful where large quantities of heat are wasted and where energy costs are high. The heat pump portion of the cycle may be either open or closed, but the Rankine cycle is usually closed.

HEAT SOURCES AND SINKS

Table 1 shows the principal media used as heat sources and heat sinks. Selection of a heat source and sink for an application is primarily influenced by geographic location, climate, initial cost, availability, and type of structure. Table 1 presents various factors to be considered for each medium.

Air

Outdoor air is a universal heat-source and heat-sink medium for heat pumps and is widely used in residential and light commercial systems. Extended-surface, forced-convection heat transfer coils transfer heat between the air and the refrigerant. Typically, the surface area of outdoor coils is 50 to 100% larger than that of indoor coils. The volume of outdoor air handled is also greater than the volume of indoor air handled by about the same percentage. During heating, the temperature of the evaporating refrigerant is generally 10 to 20°F less than the outdoor air temperature. The performance of air heating and cooling coils is given in more detail in Chapter 21 and Chapter 23.

When selecting or designing an air-source heat pump, two factors in particular must be considered: (1) the outdoor air temperature in the given locality and (2) frost formation.

As the outdoor temperature decreases, the heating capacity of an air-source heat pump decreases. This makes equipment selection for a given outdoor heating design temperature more critical for an air-source heat pump than for a fuel-fired system. The equipment must be sized for as low a balance point as is practical for heating without having excessive and unnecessary cooling capacity during the summer. A procedure for finding this balance point, which is defined as the outdoor temperature at which heat pump capacity matches heating requirements, is discussed in Chapter 45.

When the surface temperature of an outdoor air coil is 32°F or less, with a corresponding outside air dry-bulb temperature 4 to 10°F higher, frost may form on the coil surface. If allowed to accumulate, the frost inhibits heat transfer; therefore, the outdoor coil must be defrosted periodically. The number of defrosting operations is influenced by the climate, air-coil design, and the hours of operation. Experience shows that, generally, little defrosting is required when outdoor air conditions are below 17°F and 60% rh. This can be confirmed by psychrometric analysis using the principles given in Chapter 21. However, under very humid conditions, when small suspended water droplets are present in the air, the rate of frost deposit may be about three times as great as predicted from psychrometric theory. Then, the heat pump may require defrosting after as little as 20 min of operation. The loss of available heating capacity due to frosting should be taken into account when sizing an air-source heat pump.

Following commercial refrigeration practice, early designs of air-source heat pumps had relatively wide fin spacing of 4 to 5 fins/in., based on the theory that this would minimize the frequency of defrosting. However, experience has proven that effective hot-gas defrosting permits much closer fin spacing and reduced size and bulk of the system. In current practice, fin spacings of 10 to 20 fins/in. are widely used.

Table 1 Heat Pump Sources and Sinks

Medium	Examples	Suitability		Availability		Cost		Temperature		Common Practice	
		Heat Source	Heat Sink	Location Relative to Need	Coincidence with Need	Installed	Operation and Maintenance	Level	Variation	Use	Limitations
AIR											
Outdoor	Ambient air	Good, but efficiency and capacity in heating mode decrease with decreasing outdoor air temperature	Good, but efficiency and capacity in cooling mode decrease with increasing outdoor air temperature	Universal	Continuous	Low	Moderate	Variable	Generally extreme	Most common, many standard products	Defrosting and supplemental heat usually required
Exhaust	Building ventilation	Excellent	Fair	Excellent if planned for in building design	Excellent	Low to moderate	Low unless exhaust is laden with dirt or grease	Excellent	Very low	Excellent as energy-conservation measure	Insufficient for typical loads
WATER											
Well ^a	Ground-water well may also provide a potable water source	Excellent	Excellent	Poor to excellent, practical depth varies by location	Continuous	Low if existing well used or shallow wells suitable; can be high otherwise	Low, but periodic maintenance required	Generally excellent, varies by location	Extremely stable	Common	Water disposal and required permits may limit; may require double-wall exchangers; may foul or scale
Surface	Lakes, rivers, oceans	Excellent for large water bodies or high flow rates	Excellent for large water bodies or high flow rates	Limited, depends on proximity	Usually continuous	Depends on proximity and water quality	Depends on proximity and water quality	Usually satisfactory	Depends on source	Available, particularly for fresh water	Often regulated or prohibited; may clog, foul, or scale
Tap (city)	Municipal water supply	Excellent	Excellent	Excellent	Continuous	Low	Low energy cost, but water use and disposal may be costly	Excellent	Usually very low	Use is decreasing due to regulations	Use or disposal may be regulated or prohibited; may corrode or scale
Condensing	Cooling towers, refrigeration systems	Excellent	Poor to good	Varies	Varies with cooling loads	Usually low	Moderate	Favorable as heat source	Depends on source	Available	Suitable only if heating need is coincident with heat rejection
Closed loops	Building water-loop heat pump systems	Good, loop may need supplemental heat	Favorable, may need loop heat rejection	Excellent if designed as such	As needed	Low	Low to moderate	As designed	As designed	Very common	Most suitable for medium or large buildings
Waste	Raw or treated sewage, gray water	Fair to excellent	Fair, varies with source	Varies	Varies, may be adequate	Depends on proximity, high for raw sewage	Varies, may be high for raw sewage	Excellent	Usually low	Uncommon, practical only in large systems	Usually regulated; may clog, foul, scale, or corrode
GROUND^a											
Ground-coupled	Buried or submerged fluid loops	Good if ground is moist, otherwise poor	Fair to good if ground is moist, otherwise poor	Depends on soil suitability	Continuous	High to moderate	Low	Usually good	Low, particularly for vertical systems	Rapidly increasing	High initial costs for ground loop
Direct-expansion	Refrigerant circulated in ground coil	Varies with soil conditions	Varies with soil conditions	Varies with soil conditions	Continuous	High	High	Varies by design	Generally low	Extremely limited	Leak repair very expensive; requires large refrigerant quantities
SOLAR ENERGY											
Direct or heated water	Solar collectors and panels	Fair	Poor, usually unacceptable	Universal	Highly intermittent, night use requires storage	Extremely high	Moderate to high	Varies	Extreme	Very limited	Supplemental source or storage required
INDUSTRIAL PROCESS											
Process heat or exhaust	Distillation, molding, refining, washing, drying	Fair to excellent	Varies, often impractical	Varies	Varies	Varies	Generally low	Varies	Varies	Varies	May be costly unless heat need is near rejected source

^aGroundwater-source heat pumps are also considered ground-source heat pump systems.

In many institutional and commercial buildings, some air must be continuously exhausted year-round. This exhaust air can be used as a heat source, although supplemental heat is generally necessary.

The high humidity due to indoor swimming pools causes condensation on ceiling structural members, walls, windows, and floors and causes discomfort to spectators. Traditionally, outside air and dehumidification coils with reheat from a boiler that also heats the pool water are used. This application is ideal for air-to-air and air-to-water heat pumps because energy costs can be reduced. Suitable materials must be chosen so that the heat pump components are resistant to corrosion from chlorine and high humidity.

Water

Water can be a satisfactory heat source, subject to the considerations listed in [Table 1](#). City water is seldom used because of cost and municipal restrictions. Groundwater (well water) is particularly attractive as a heat source because of its relatively high and nearly constant temperature. The water temperature is a function of source depth and climate, but, in the United States, generally ranges from 40°F in northern areas to 70°F in southern areas. Frequently, sufficient water is available from wells for which the water can be reinjected into the aquifer. The use is nonconsumptive and, with proper design, only the water temperature changes. The water quality should be analyzed, and the possibility of scale formation and corrosion should be considered. In some instances, it may be necessary to separate the well fluid from the equipment with an additional heat exchanger. Special consideration must also be given to filtering and settling ponds for specific fluids. Other considerations are the costs of drilling, piping, pumping, and a means for disposal of used water. Information on well water availability, temperature, and chemical and physical analysis is available from U.S. Geological Survey offices in many major cities.

Heat exchangers may also be submerged in open ponds, lakes, or streams. When surface or stream water is used as a source, the temperature drop across the evaporator in winter may need to be limited to prevent freeze-up.

In industrial applications, waste process water (e.g., spent warm water in laundries, plant effluent, and warm condenser water) may be a heat source for heat pump operation.

Sewage, which often has temperatures higher than that of surface or groundwater, may be an acceptable heat source. Secondary effluent (treated sewage) is usually preferred, but untreated sewage may be used successfully with proper heat exchanger design.

Use of water during cooling follows the conventional practice for water-cooled condensers.

Water-to-refrigerant heat exchangers are generally direct-expansion or flooded water coolers, usually of the shell-and-coil or shell-and-tube type. Brazed plate heat exchangers may also be used. In large applied heat pumps, the water is usually reversed instead of the refrigerant.

Ground

The ground is used extensively as a heat source and sink, with heat transfer through buried coils. Soil composition, which varies widely from wet clay to sandy soil, has a predominant effect on thermal properties and expected overall performance. The heat transfer process in soil depends on transient heat flow. Thermal diffusivity is a dominant factor and is difficult to determine without local soil data. Thermal diffusivity is the ratio of thermal conductivity to the product of density and specific heat. The soil moisture content influences its thermal conductivity.

There are three primary types of ground-source heat pumps: (1) groundwater, which is discussed in the previous section; (2) direct-expansion, in which the ground-to-refrigerant heat exchanger is buried underground; and (3) ground-coupled (also called closed-loop ground-source), in which a secondary loop with a brine con-

nects the ground-to-water and water-to-refrigerant heat exchangers (see [Figure 5](#)).

Ground loops can be placed either horizontally or vertically. A horizontal system consists of single, or multiple, serpentine heat exchanger pipes buried 3 to 6 ft apart in a horizontal plane at a depth 3 to 6 ft below grade. Pipes may be buried deeper, but excavation costs and temperature must be considered. Horizontal systems that use coiled loops referred to as **slinky coils** are also used. A vertical system uses a concentric tube or U-tube heat exchanger. The design of ground-coupled heat exchangers is covered in [Chapter 32 of the ASHRAE Handbook—Applications](#).

Solar Energy

Solar energy may be used either as the primary heat source or in combination with other sources. Air, surface water, shallow groundwater, and shallow ground-source systems all use solar energy indirectly. The principal advantage of using solar energy directly as a heat source for heat pumps is that, when available, it provides heat at a higher temperature than the indirect sources, resulting in an increase in the heating coefficient of performance. Compared to solar heating without a heat pump, the collector efficiency and capacity are increased because a lower collector temperature is required.

Research and development of solar-source heat pumps has been concerned with two basic types of systems—direct and indirect. The direct system places refrigerant evaporator tubes in a solar collector, usually a flat-plate type. Research shows that a collector without glass cover plates can also extract heat from the outdoor air. The same surface may then serve as a condenser using outdoor air as a heat sink for cooling.

An indirect system circulates either water or air through the solar collector. When air is used, the collector may be controlled in such a way that (1) the collector can serve as an outdoor air preheater, (2) the outdoor air loop can be closed so that all source heat is derived from the sun, or (3) the collector can be disconnected from the outdoor air serving as the source or sink.

TYPES OF HEAT PUMPS

Heat pumps are classified by (1) heat source and sink, (2) heating and cooling distribution fluid, (3) thermodynamic cycle, (4) building structure, (5) size and configuration, and (6) limitation of the source and the sink. [Figure 5](#) shows the more common types of closed vapor compression cycle heat pumps for heating and cooling service.

Air-to-Air Heat Pumps. This type of heat pump is the most common and is particularly suitable for factory-built unitary heat pumps. It is widely used in residential and commercial applications (see [Chapter 45](#)). The first diagram in [Figure 5](#) is typical of the refrigeration circuit used.

In air-to-air heat pump systems, the air circuits can be interchanged by motor-driven or manually operated dampers to obtain either heated or cooled air for the conditioned space. In this system, one heat exchanger coil is always the evaporator, and the other is always the condenser. The conditioned air passes over the evaporator during the cooling cycle, and the outdoor air passes over the condenser. The positioning of the dampers causes the change from cooling to heating.

Water-to-Air Heat Pumps. These heat pumps rely on water as the heat source and sink, and use air to transmit heat to, or from, the conditioned space. See the second diagram in [Figure 5](#). They include the following:

- **Groundwater heat pumps**, which use groundwater from wells as a heat source and/or sink. These systems can either circulate the source water directly to the heat pump or use an intermediate fluid in a closed loop, similar to the ground-coupled heat pump.



Heat Source and Sink	Distribution Fluid	Thermal Cycle	Diagram		
			 Heating	 Cooling	 Heating and Cooling
Air	Air	Refrigerant changeover			
Water	Air	Refrigerant changeover			
Water	Water	Water changeover			
Ground-coupled (or Closed-loop ground-source)	Air	Refrigerant changeover			
Ground-source, Direct-expansion	Air	Refrigerant changeover			

Fig. 5 Heat Pump Types

- **Surface water heat pumps**, which use surface water from either a lake, pond, or stream as a heat source or sink. Similar to the ground-coupled and groundwater heat pumps, these systems can either circulate the source water directly to the heat pump or use an intermediate fluid in a closed loop.
- **Internal-source heat pumps**, which use the high internal cooling load generated in modern buildings either directly or with storage. These include water loop heat pumps.
- **Solar-assisted heat pumps**, which rely on low-temperature solar heat as the heat source. Solar heat pumps may resemble water-to-air, or other types, depending on the form of solar heat collector and the type of heating and cooling distribution system.
- **Wastewater-source heat pumps**, which use sanitary waste heat or laundry waste heat as a heat source. The waste fluid can be introduced directly into the heat pump evaporator after waste filtration, or it can be taken from a storage tank, depending on the application. An intermediate loop may also be used for heat transfer between the evaporator and the waste heat source.

Water-to-Water Heat Pumps. These heat pumps use water as the heat source and sink for cooling and heating. Heating-cooling changeover can be done in the refrigerant circuit, but it is often more convenient to perform the switching in the water circuits, as shown in the third diagram of [Figure 5](#). Although the diagram shows direct admittance of the water source to the evaporator, in some cases, it may be necessary to apply the water source indirectly through a heat exchanger (or double-wall evaporator) to avoid contaminating the closed chilled water system, which is normally treated. Another method uses a closed-circuit condenser water system.

Ground-Coupled Heat Pumps. These use the ground as a heat source and sink. A heat pump may have a refrigerant-to-water heat exchanger or may be of the direct-expansion (DX) type. Both types are shown in [Figure 5](#). In systems with refrigerant-to-water heat exchangers, a water or antifreeze solution is pumped through horizontal, vertical, or coiled pipes embedded in the ground. Direct-expansion ground-coupled heat pumps use refrigerant in direct-expansion, flooded, or recirculation evaporator circuits for the ground pipe coils.

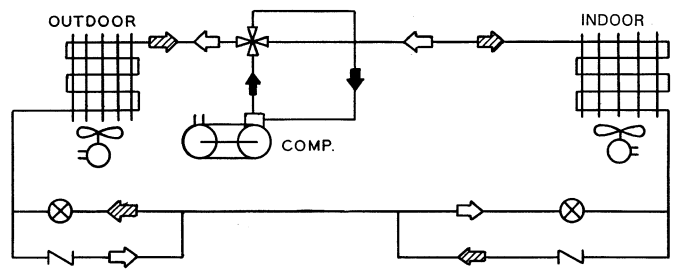
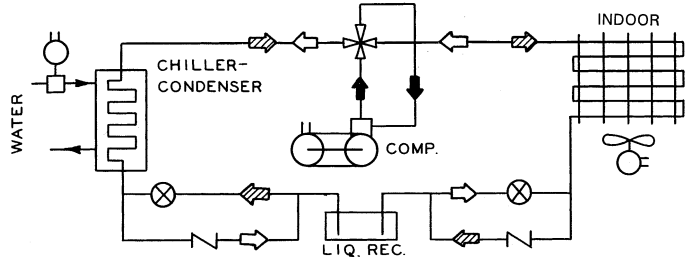
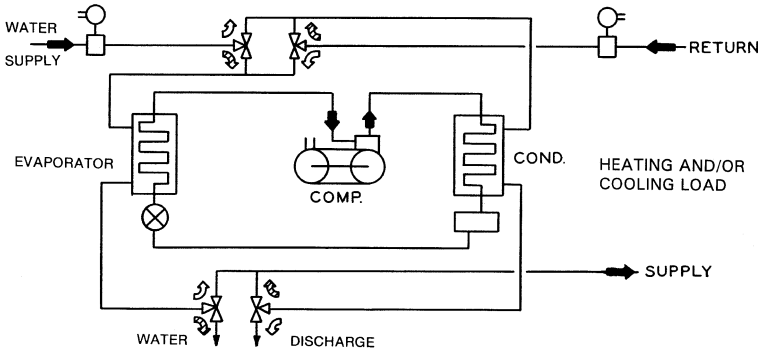
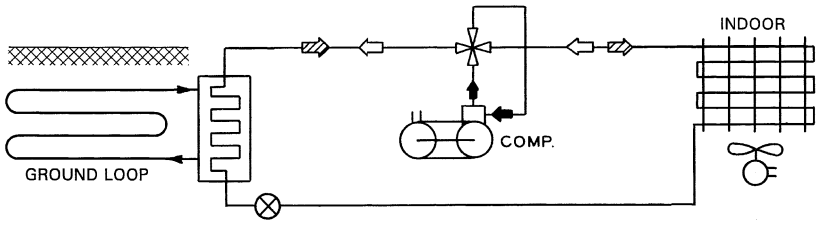
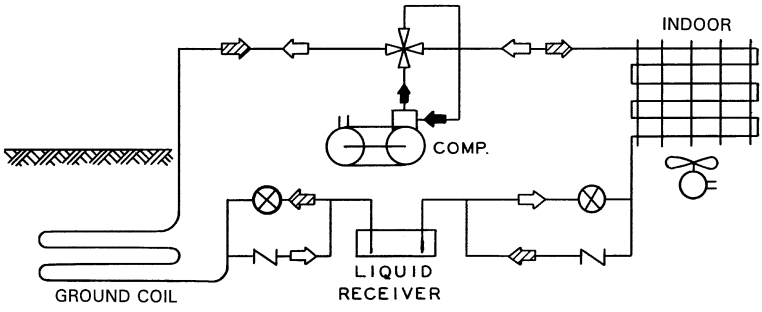
Soil type, moisture content, composition, density, and uniformity close to the surrounding field areas affect the success of this method of heat exchange. With some piping materials, the material of construction for the pipe and the corrosiveness of the local soil and underground water may affect the heat transfer and service life. In a variation of this cycle, all or part of the heat from the evaporator plus the heat of compression are transferred to a water-cooled condenser. This condenser heat is then available for uses such as heating air or domestic hot water.

Additional heat pump types include the following:

Air-to-Water Heat Pumps Without Changeover. These are commonly called heat pump water heaters.

Refrigerant-to-Water Heat Pumps. These condense a refrigerant by the cascade principle. Cascading pumps the heat to a higher temperature, where it is rejected to water or another liquid. This type of heat pump can also serve as a condensing unit to cool almost any fluid or process. More than one heat source can be used to offset those times when insufficient heat is available from the primary source.

HEAT PUMP COMPONENTS

For the most part, the components and practices associated with heat pumps evolved from work with low-temperature refrigeration. This section outlines the major components and discusses characteristics or special considerations that apply to heat pumps in combined room heating and air-conditioning applications or in higher temperature industrial applications.

Compressors

The principal types of compressors used in applied heat pump systems are briefly described in this section. For more details on these compressor types and others, refer to [Chapter 34](#).

- **Centrifugal compressors.** Most centrifugal applications in heat pumps have been limited to large water-to-water or refrigerant-to-water heat pump systems, heat transfer systems, storage systems, and hydronically cascaded systems. With these applications, the centrifugal compressor enables the use of heat pumps in industrial plants, as well as in large multistory buildings; many installations with double-bundle condensers have been made. The transfer cycles permit low pressure ratios, and many single- and two-stage units with various refrigerants are operational with high COPs. Centrifugal compressor characteristics do not usually meet the needs of air-source heat pumps. High pressure ratios, or high lifts, associated with low gas volume at low load conditions cause the centrifugal compressor to surge.
- **Screw compressors.** Screw compressors offer high pressure ratios at low to high capacities. Capacity control is usually provided by such means as variable porting or sliding vanes. Generally, large oil separators are required, because many compressors use oil injection. Screw compressors are less susceptible to damage from liquid spillover and have fewer parts than do reciprocating compressors. They also simplify capacity modulation.
- **Rotary vane compressors.** These compressors can be used for the low stage of a multistage plant; they have a high capacity but are generally limited to lower pressure ratios. They also have limited means for capacity reduction.
- **Reciprocating compressors.** These compressors are used more than any other type on systems ranging from 0.5 to 100 tons.
- **Scroll compressors.** These are a type of orbital motion positive-displacement compressor. Their use in heat pump systems is increasing. Their capacity can be controlled by varying the drive speed or the compressor displacement. Scroll compressors have low noise and vibration levels.

Compressor Selection. A compressor used for comfort cooling usually has a medium clearance volume ratio (the ratio of gas volume remaining in the cylinder after compression to the total swept volume). For an air-source heat pump, a compressor with a smaller clearance volume ratio is more suitable for low-temperature operation and provides greater refrigerating capacity at lower evaporator temperatures. However, this compressor has somewhat more power demand under maximum cooling load conditions than a compressor with medium clearance.

More total heat capacity can be obtained at low outdoor temperatures by deliberately oversizing the compressor. When this is done, some capacity reduction for operation at higher outdoor temperatures can be provided by multispeed or variable-speed drives, cylinder cutouts, or other methods. The disadvantage of this arrangement is that the greater number of operating hours that occur at the higher suction temperatures must be served with the compressor in the unloaded condition, which generally causes lower efficiency and higher annual operating cost. The additional initial cost of the oversized compressor must be economically justified by the gain in heating capacity.

One method proposed for increasing the heating output at low temperatures uses **staged compression**. For example, one compressor may compress from -30°F saturated suction temperature (SST) to 40°F saturated discharge temperature (SDT), and a second compressor compresses the vapor from 40°F SST to 120°F SDT. In this arrangement, the two compressors may be interconnected in parallel, with both pumping from about 45°F SST to 120°F SDT for cooling. Then at some predetermined outdoor temperature on heating, they are reconnected in series and compress in two successive stages.

Figure 6 shows the performance of a pair of compressors for units of both medium and low clearance volume. At low suction temperatures, the reconnection in series adds some capacity. However, the motor for this case must be selected for the maximum loading conditions for summer operation, even though the low-stage compressor has a greatly reduced power requirement under the heating condition.

Compressor Floodback Protection. A suction line separator, similar to that shown in Figure 7, in combination with a liquid-gas heat exchanger, can be used to minimize migration and harmful liquid floodback to the compressor. The solenoid valve should be controlled to open when the compressor is operating, and the hand valve should then be adjusted to provide an acceptable bleed rate into the suction line.

Heat Transfer Components

Refrigerant-to-air and refrigerant-to-water heat exchangers are similar to heat exchangers used in air-conditioning refrigeration systems.

Defrosting Air-Source Coils. Frost accumulates rather heavily on outdoor air-source coils when the outdoor air temperature is less

than approximately 40°F, but lessens somewhat with the simultaneous decrease in outdoor temperature and moisture content. Most systems defrost by reversing the cycle.

Another method of defrosting is spraying heated water over an outdoor coil. The water can be heated by the refrigerant or by auxiliaries.

Draining Heat Source and Heat Sink Coils. Direct-expansion indoor and outdoor heat transfer surfaces serve as condensers and evaporators. Both surfaces, therefore, must have proper refrigerant distribution headers to serve as evaporators and have suitable liquid refrigerant drainage while serving as condensers.

In a flooded system, the normal float control to maintain the required liquid refrigerant level is used.

Liquid Subcooling Coils. A refrigerant subcooling coil can be added to the heat pump cycle, as illustrated in Figure 8, to preheat the ventilation air during the heating cycle and, at the same time, to lower the temperature of the liquid refrigerant. Depending on the refrigerant circulation rate and the quantity and temperature of ventilation air, the heating capacity can be increased as much as 15 to 20%, as indicated in Figure 9.

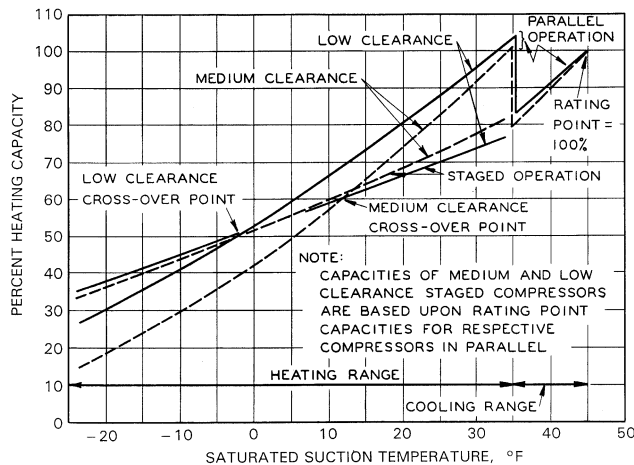

Fig. 6 Comparison of Parallel and Staged Operation for Air-Source Heat Pumps

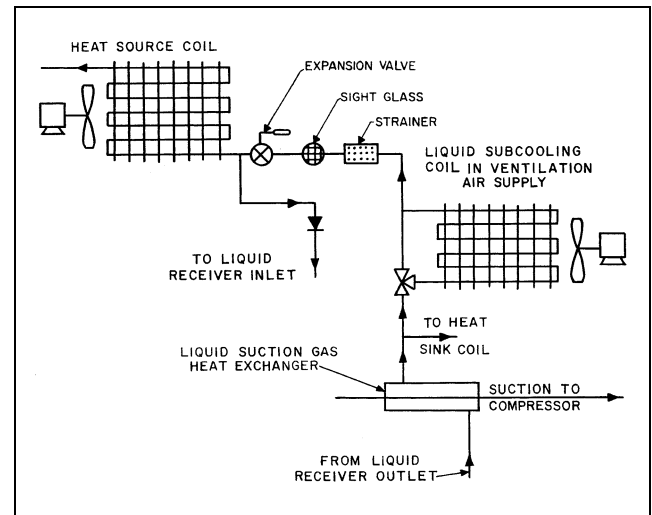

Fig. 8 Liquid Subcooling Coil in Ventilation Air Supply to Increase Heating Effect and Heating COP

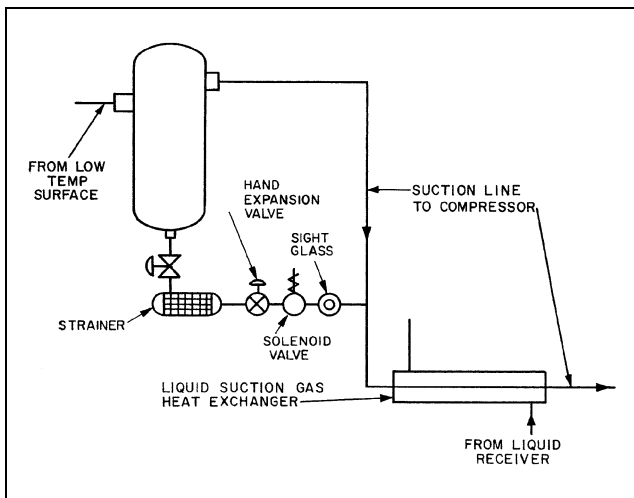

Fig. 7 Suction Line Separator for Protection Against Liquid Floodback

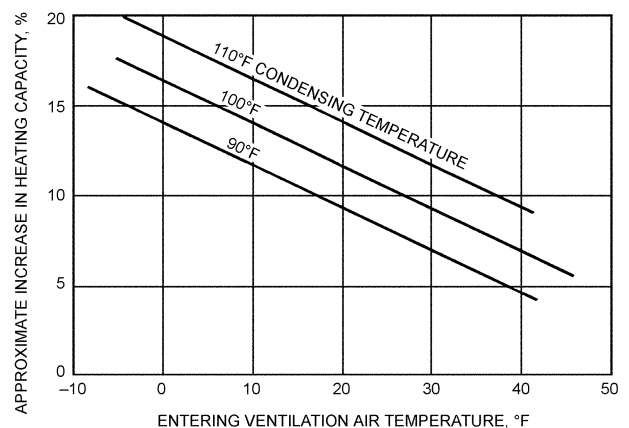

Fig. 9 Typical Increase in Heating Capacity Resulting from Use of Liquid Subcooling Coil

Refrigeration Components

Refrigerant piping, receivers, expansion devices, and refrigeration accessories in heat pumps are usually the same as components found in other types of refrigeration and air-conditioning systems.

A **reversing valve** changes the system from the cooling to the heating mode. This changeover requires the use of a valve(s) in the refrigerant circuit, except where the change occurs in fluid circuits external to the refrigerant circuit. Reversing valves are usually pilot-operated by solenoid valves, which admit compressor head and suction pressures to move the operating elements.

The **expansion device** for controlling the refrigerant flow is normally a **thermostatic expansion valve**, which is described in [Chapter 45 of the ASHRAE Handbook—Refrigeration](#). The control bulb must be located carefully. If the circuit is arranged so that the refrigerant line on which the control bulb is placed can become the compressor discharge line, the resulting pressure developed in the valve power element may be excessive, requiring a special control charge or a pressure-limiting element. When a thermostatic expansion valve is applied to an outdoor air coil, a special cross-charge to limit the superheat at low temperatures allows better use of the coil. In its temperature-sensing element, a cross-charged thermostatic expansion valve uses a fluid, or mixture of fluids, that is different than the refrigerant. An **electronic expansion valve** provides improved control of refrigerant flow.

A **capillary tube** (used as a metering device for an air-source heat pump that operates over a wide range of evaporating temperatures) may pass refrigerant at an excessive rate at low back pressures, causing liquid floodback to the compressor. In some cases, suction line accumulators or charge-control devices are added to minimize this effect. Suction line accumulators may also prevent liquid refrigerant, which has migrated to the evaporator, from entering the compressor on start-up.

When separate metering devices are used for the two heat exchangers, a **check valve** allows the refrigerant to bypass the metering device of the heat exchanger serving as the condenser.

A **refrigerant receiver**, which is commonly used as a storage place for liquid refrigerant, is particularly useful in a heat pump to take care of the unequal refrigerant requirements of heating and cooling. The receiver is usually omitted on heat pumps used for heating only.

Controls

Defrost Control. A variety of defrosting control schemes can sense the need for defrosting air-source heat pumps and initiate (and terminate) the defrost cycle. The cycle is usually initiated by demand rather than a timer. Termination of the cycle may be timer-controlled.

The defrost cycle can also be terminated either by a control sensing the coil pressure or a thermostat that measures the temperature of the liquid refrigerant in the outdoor coil. The completion of defrosting is ensured when the temperature (or corresponding saturation pressure) of the liquid leaving the outdoor coil rises to about 70°F.

A widely used means of starting the defrost cycle on demand is a pressure control that reacts to the air pressure drop across the coil. When frost accumulates, the airflow is reduced and the increased pressure drop across the coil initiates the defrost cycle. This method is applicable only in a clean outdoor environment where fouling of the air side of the outdoor coil is not expected.

Another method for sensing frost formation and initiating defrosting on demand involves a temperature differential control and two temperature-sensing elements. One element is responsive to outdoor-air temperature and the other to the temperature of the refrigerant in the coil. As frost accumulates, the differential between the outdoor temperature and the refrigerant temperature increases, initiating a defrost cycle. The system is restored to operation when

the refrigerant temperature in the coil reaches a specified temperature, indicating that defrosting has been completed. When the outdoor air temperature decreases, the differential between outdoor air temperature and refrigerant temperature decreases due to reduced heat pump capacity. Thus, unless compensation is provided, the defrost cycle is not initiated until a greater amount of frost has built up.

The following controls may be used to change from heating to cooling:

- **Conditioned space thermostats** on residences and small commercial applications.
- **Outdoor air thermostats** (with provision for manual overriding for variable solar and internal load conditions) on larger installations, where it may be difficult to find a location in the conditioned space that is representative of the total building.
- **Manual changeover** via a heat-off-cool position on the indoor thermostat. A single thermostat is used for each heat pump unit.
- **Sensing devices**, which respond to the greater load requirement, heating or cooling, are generally applied on simultaneous heating and cooling systems.
- **Dedicated microcomputers** to automate changeover and perform all the other control functions needed, as well as to simultaneously monitor the performance of the system. This may be a stand-alone device, or it may be incorporated as part of a larger building automation system.

On the heat pump system, it is important that space thermostats are interlocked with ventilation dampers so that both operate on the same cycle. During the heating cycle, the fresh air damper should be positioned for the minimum required ventilation air, with the space thermostat calling for increased ventilation air only if the conditioned space becomes too warm. Fan and/or pump interlocks are generally provided to prevent the heat pump system from operating if the use of the accessory equipment is not available. On commercial and industrial installations, some form of head pressure control is required on the condenser when cooling at outdoor air temperatures below 60°F.

Supplemental Heating

Heating needs may exceed the heating capacity available from equipment selected for the cooling load, particularly if outdoor air is used as the heat source. When this occurs, supplemental heating or additional compressor capacity should be considered. The additional compressor capacity or the supplemental heat is generally used only in the severest winter weather and, consequently, has a low usage factor. Both possibilities must be evaluated to determine the most economical selection.

When supplemental heaters are used, the elements should always be located in the air or water circuit downstream from the heat pump condenser. This permits the heat pump system to operate at a lower condensing temperature, increasing the system heating capacity and improving the coefficient of performance. The controls should sequence the heaters so that they are energized after all heat pump compressors are fully loaded. An outdoor thermostat is recommended to limit or prevent energizing heater elements during mild weather when they are not needed. Where 100% supplemental heat is provided for emergency operation, it may be desirable to keep one or more stages of the heaters locked out whenever the compressor is running. In this way, the cost of electrical service to the building is reduced by limiting the maximum coincidental demand.

A flow switch should be used to prevent operation of the heating elements and the heat pump when there is no air or water flow.

INDUSTRIAL PROCESS HEAT PUMPS

Heat recovery in industry offers numerous opportunities for applied heat pumps. The two major classes of industrial heat pump

systems are closed-cycle and open-cycle. Factory-packaged, closed-cycle machines have been built to heat fluids to 120°F and as high as 220°F. Skid-mounted, open-cycle and semi-open-cycle machines have been used to produce low-level, saturated and superheated steam.

In industrial applications, heat pumps are generally used for process heating rather than space heating. Each heat pump system must be designed for the particular application. Rather than being dictated by weather or design standards, the selection of size and output temperature for a system is often affected by economic restraints, environmental standards, or desired levels of product quality or output. This gives the designer more flexibility in equipment selection because the systems are frequently applied in conjunction with a more traditional process heating system such as steam.

ASHRAE Research Project 656 (Cane et al. 1994) gathered information on energy performance, economics of operation, operating difficulties, operator and management reactions, and design details for various **heat recovery heat pump** (HRHP) systems.

The most common reason given for installing HRHP systems was reduction of energy cost. Other reasons cited were

- Need to eliminate bacterial growth in storage tanks
- Need to increase ammonia refrigeration system capacity
- Reduction of makeup water use
- Need for flexibility in processing
- Year-round processing (drying) possible
- Superior drying quality compared with conventional forced-air kilns
- Process emissions eliminated without the need for costly pollution control equipment
- Recovery and reuse of product from process
- Reduced effluent into the environment

Economics associated with energy reductions were calculated for most of the test sites. Economic justifications for the other reasons for installation were difficult to estimate. Only half the survey sites reported actual payback periods. Half of these had simple paybacks of less than 5 years.

The most frequently cited problem was widely fluctuating heat source or sink flow rates or temperatures. Considerable differences between design parameters and actual conditions were also mentioned frequently. In some cases, the difference resulted in oversizing, which caused poor response to load variation, nuisance shutdowns, and equipment failure. Other problems were significant process changes after installation and poor placement of the HRHP.

The number of projects that had overstated savings based on overstated run hours demonstrated the need for accurate prediction method. While the low hours of use in some cases resulted from first-year start-up and balancing issues, in most cases it was due to plant capacity reductions, process modifications, or other factors that were not understood during the design phase.

Closed-Cycle Systems

Closed-cycle systems use a suitable working fluid, usually a refrigerant in a sealed system. They can use either the absorption or the vapor compression principle. Traditionally, vapor compression systems have used R-11, R-12, R-113, and R-114 to obtain the desired temperature; however, these refrigerants are being phased out. Refrigerants R-22 and R-134a can be used in vapor compression systems if the output temperature requirements are adjusted to meet the pressure restrictions of the refrigerant and machine selected. Heat is transferred to and from the system through heat exchangers similar to refrigeration system heat exchangers. Closed-cycle heat pump systems are often classed with industrial refrigeration systems except that they operate at higher temperatures.

Heat exchangers selected for the system must comply with federal and local codes. For example, some jurisdictions require

a double separation between potable water and refrigerant. Heat exchangers must be resistant to corrosion and fouling conditions of the source and sink fluids. The refrigerant and oil must be (1) compatible with component materials and (2) mutually compatible at the expected operating temperatures. In addition, the viscosity and foaming characteristics of the oil and refrigerant mixtures must be consistent with the lubrication requirements at the specific mechanical load imposed on the equipment. Proper oil return and heat transfer at the evaporators and condensers must also be considered.

The specific application of a closed-cycle heat pump frequently dictates the selection considerations. In this section, the different types of closed-cycle systems are reviewed, and factors important to the selection process are addressed.

Air-to-air heat pumps or **dehumidification heat pumps** (Figure 10) are most frequently used in industrial operations to dry or cure products. For example, dehumidification kilns are used to dry lumber to improve its value. Compared to conventional steam kilns, the heat pump provides two major benefits: improved product quality and reduced percent degrade. With dehumidification, lumber can be dried at a lower temperature, which reduces warping, cracking, checking, and discoloration. The system must be selected according to the type of wood (i.e., hard or soft) and the required dry time. Dehumidification heat pumps can also be used to dry agricultural products; poultry, fish, and meat; textiles; and other products.

Air-to-water heat pumps, which are also called **heat pump water heaters**, are a special application of closed-cycle systems that are usually unitary. See Chapter 45 of this volume and Chapter 49 of the *ASHRAE Handbook—Applications* for more information.

Water-to-water heat pumps may have the most widespread application in industry. They can use cooling tower water, effluent streams, and even chilled water makeup streams as heat sources. The output hot water can be used for product rinse tanks, equipment cleanup water systems, and product preheaters. The water-to-water heat pump system may be simple, such as that shown in Figure 11, which recovers heat from a process cooling tower to heat water for another process. Figure 11 also shows the integration of a heat exchanger for preheating the process water. Typically, the heat pump COP is in the range of 4 to 6, and the system COP reaches 8 to 15.

Water-to-water heat pump systems may also be complicated, such as the cascaded HRHP system (Figure 12) for a textile dyeing and finishing plant. Heat recovered from various process effluent streams is used to preheat makeup water for the processes. The effluent streams may contain materials, such as lint and yarn, and

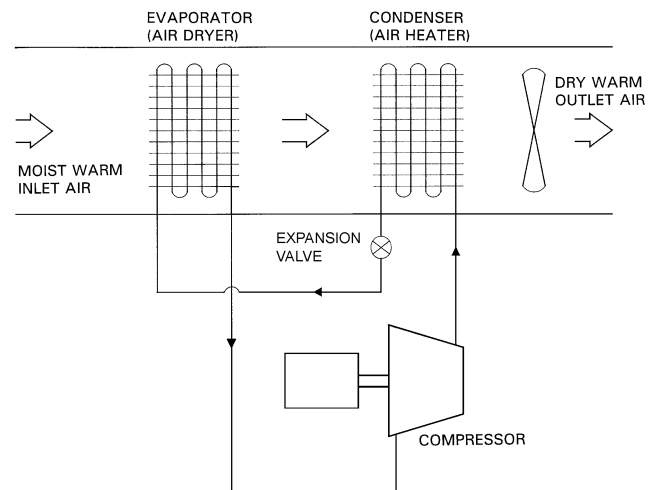

Fig. 10 Dehumidification Heat Pump

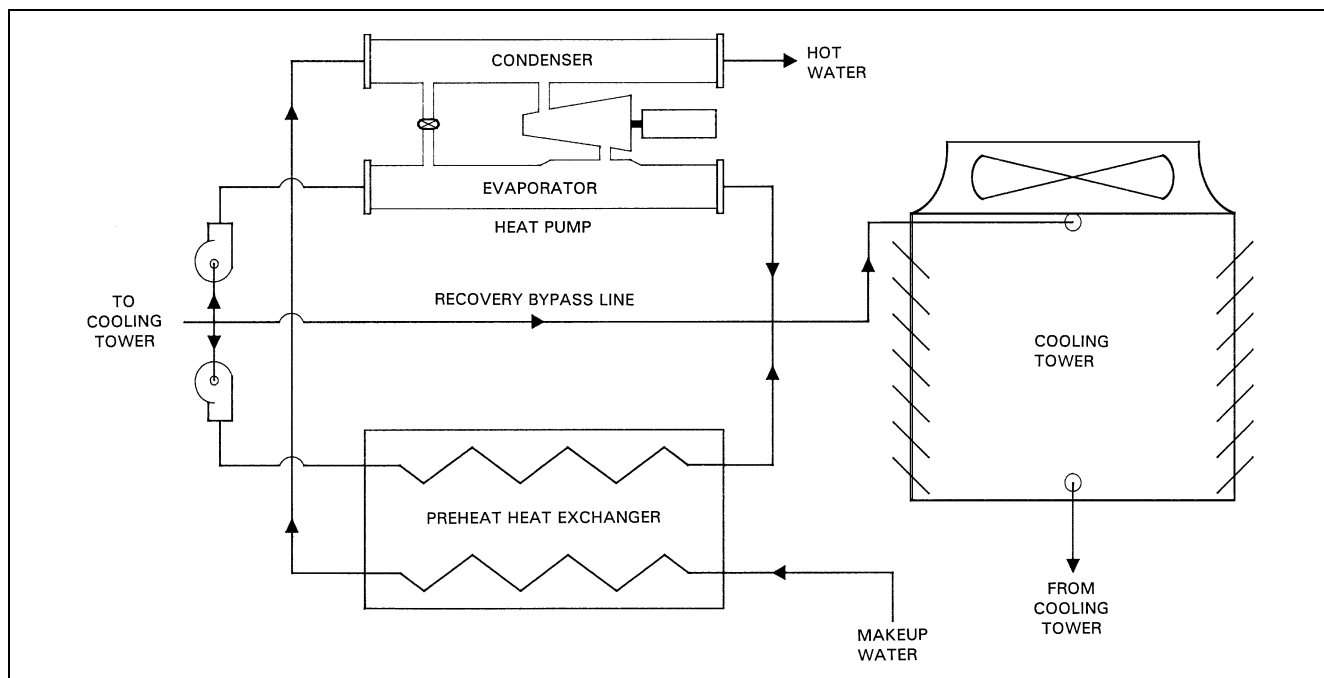

Fig. 11 Cooling Tower Heat Recovery Heat Pump

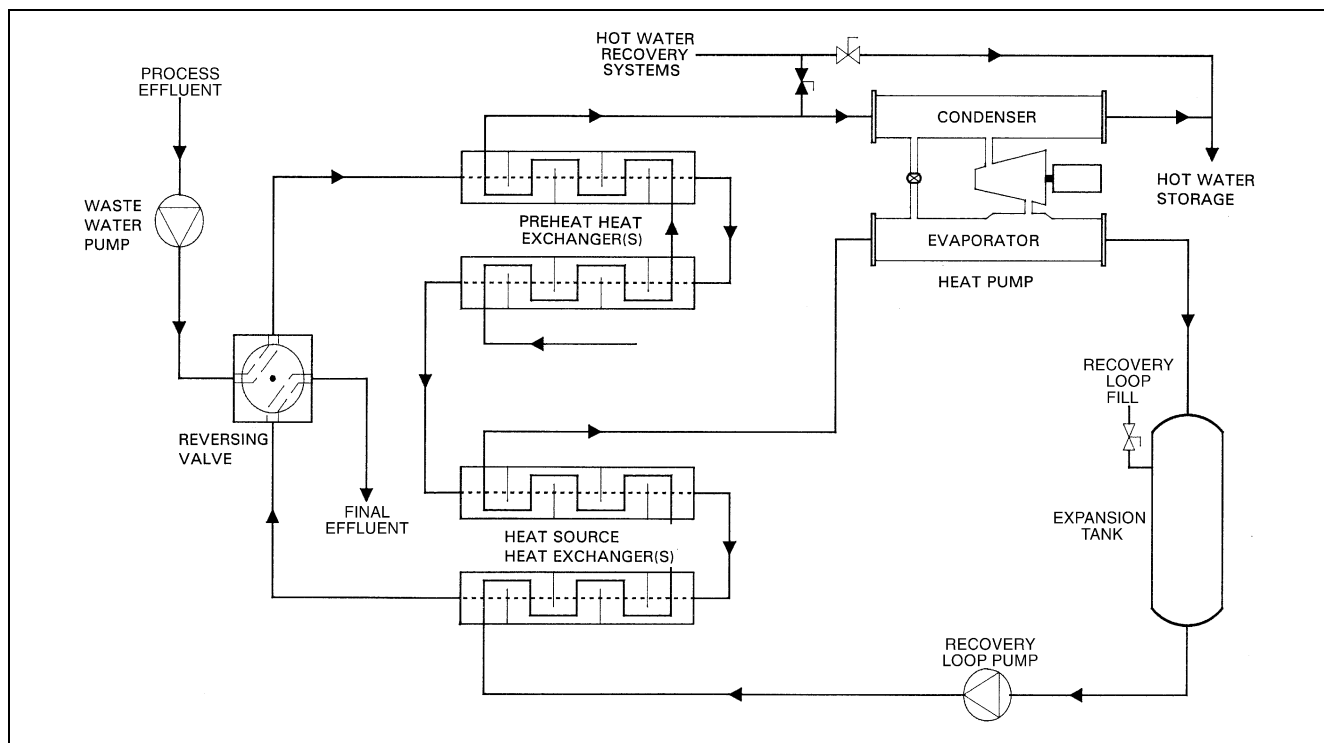

Fig. 12 Effluent Heat Recovery Heat Pump

highly corrosive chemicals that may foul the heat exchanger; therefore, special materials and antifouling devices may be needed for the heat exchanger for a successful design.

Most food-processing plants, which use more water than a desuperheater or a combination desuperheater/condenser can provide, can use a water-to-water heat pump (Figure 13). A water-cooled condenser recovers both sensible and latent heat from the high-pressure refrigerant. The water heated in the condenser is split

into two streams—one as a heat source for the water-to-water heat pump, the other to preheat the makeup process and cleanup water. The preheated water is blended with hot water from the storage tank to limit the temperature difference across the heat pump condenser to about 20°F, which is standard for many chiller applications. The heated water is then piped back to the storage tank, which is typically sized for 1.5 to 5 h of holding capacity. Because the refrigeration load may be insufficient to provide all the water heating,

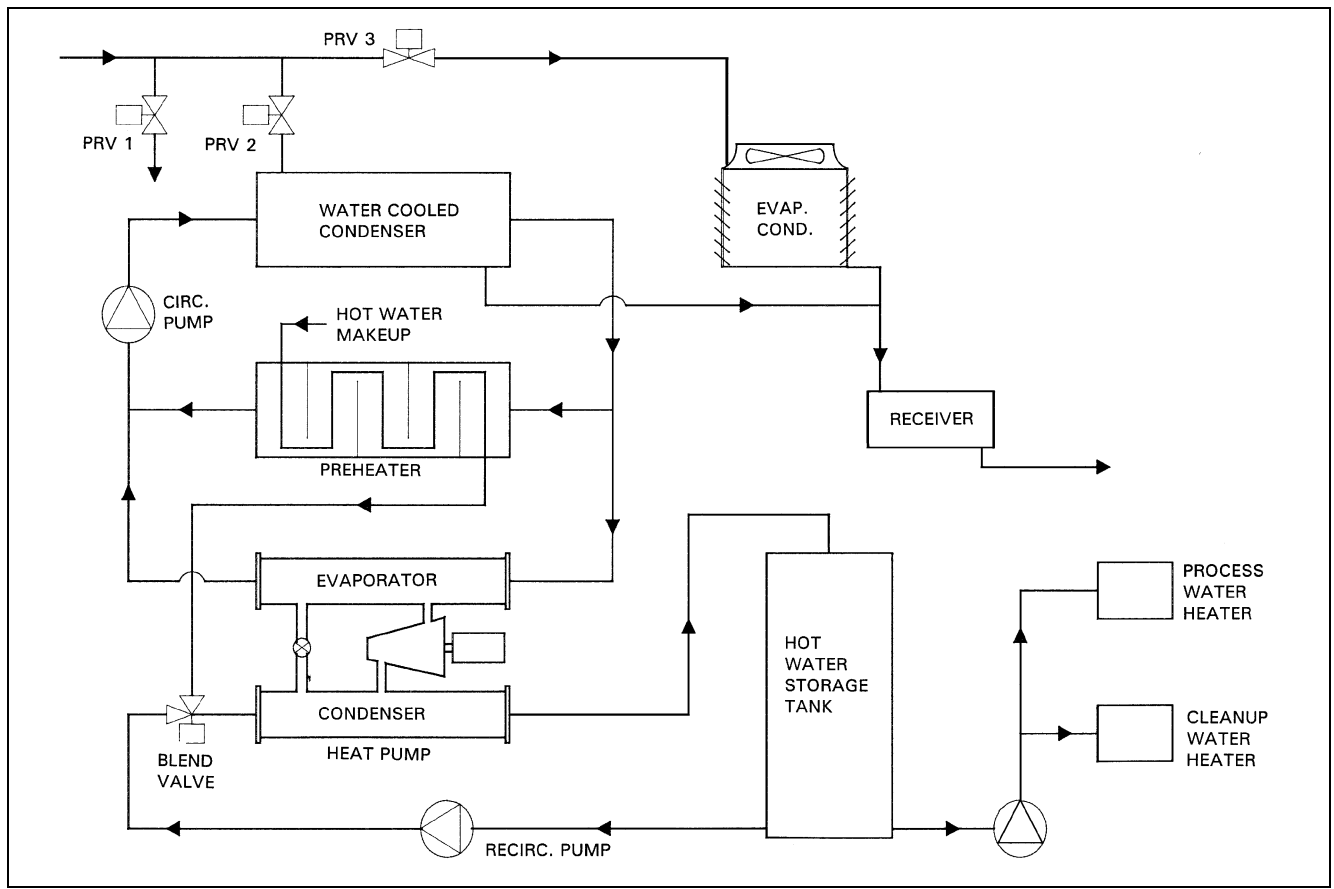

Fig. 13 Refrigeration Heat Recovery Heat Pump

existing water heaters (usually steam) provide additional heat and control for process water at the point of use.

Three major factors tasks must be addressed when adding heat recovery to existing plant refrigeration systems: (1) forcing the hot-gas refrigerant to flow to the desired heat exchanger, (2) scheduling the refrigeration processes to provide an adequate heat source over time while still meeting process requirements, and (3) integrating water-cooled, shell-and-tube condensers with evaporative condensers. The refrigerant direction can be controlled either by series piping of the two condenser systems or by three pressure-regulating valves—one to the hot-gas defrost (the lowest pressure setting), one to the recovery system (the medium-pressure setting), and one to the evaporative condensers (the highest pressure setting). The pressure-regulating valves offer good control but can be mechanically complicated. The series piping is simple but can cost more because of the pipe size required for all the hot gas to pass through the water-cooled condenser.

Each refrigeration load should be reviewed for its required output and production requirements. For example, ice production can frequently be scheduled during cleanup periods, and blast freezing for the end of shifts.

In multisystem integration, as in expanded system integration, equalization lines, liquid lines, receivers, and so forth must be designed according to standard refrigeration practices.

Process-fluid-to-process-fluid heat pumps can be applied to evaporation, concentration, crystallization, and distillation process fluids that contain chemicals that would destroy a steam compressor. A closed-cycle vapor compression system (Figure 14) is used for the separation of a solid and a liquid in an evaporator system and for the separation of two liquids in a distillation system. Both systems frequently have COPs of 8 to 10 and have the added benefit of

cooling tower elimination. These systems can frequently be specified and supplied by the column or evaporator manufacturer as a value-added system.

The benefits of water-to-water, refrigerant-to-water, and other fluid-to-fluid systems may include the following:

- Lower energy costs due to the switch from fuel-based water heating to heat recovery water heating.
- Reduced costs for water-treatment chemicals for the boiler due to the switch from a steam-based system.
- Reduced emissions of NO_x , SO_x , CO , CO_2 , and other harmful chemicals due to reduced boiler loading.
- Decreased effluent temperature, which improves the effectiveness of the water treatment process that breaks down solids.
- Increased production due to the increased temperature of the water available at the start of process cycles. For processes requiring a cooler start temperature, the preheated water may be blended with ambient water.
- Higher product quality due to rinsing with water at a higher temperature. Blending the preheated water with ambient water may be necessary if a cooler temperature is required.
- Reduced water and chemical consumption at cooling towers and evaporative condensers.
- More efficient process cooling if the heat recovery can be used to reduce refrigeration pressure or cooling tower return temperature.
- Reduced scaling of heat exchangers due to the lower surface temperatures in heat pump systems as compared to steam coils, forced-air gas systems, and resistance heaters.

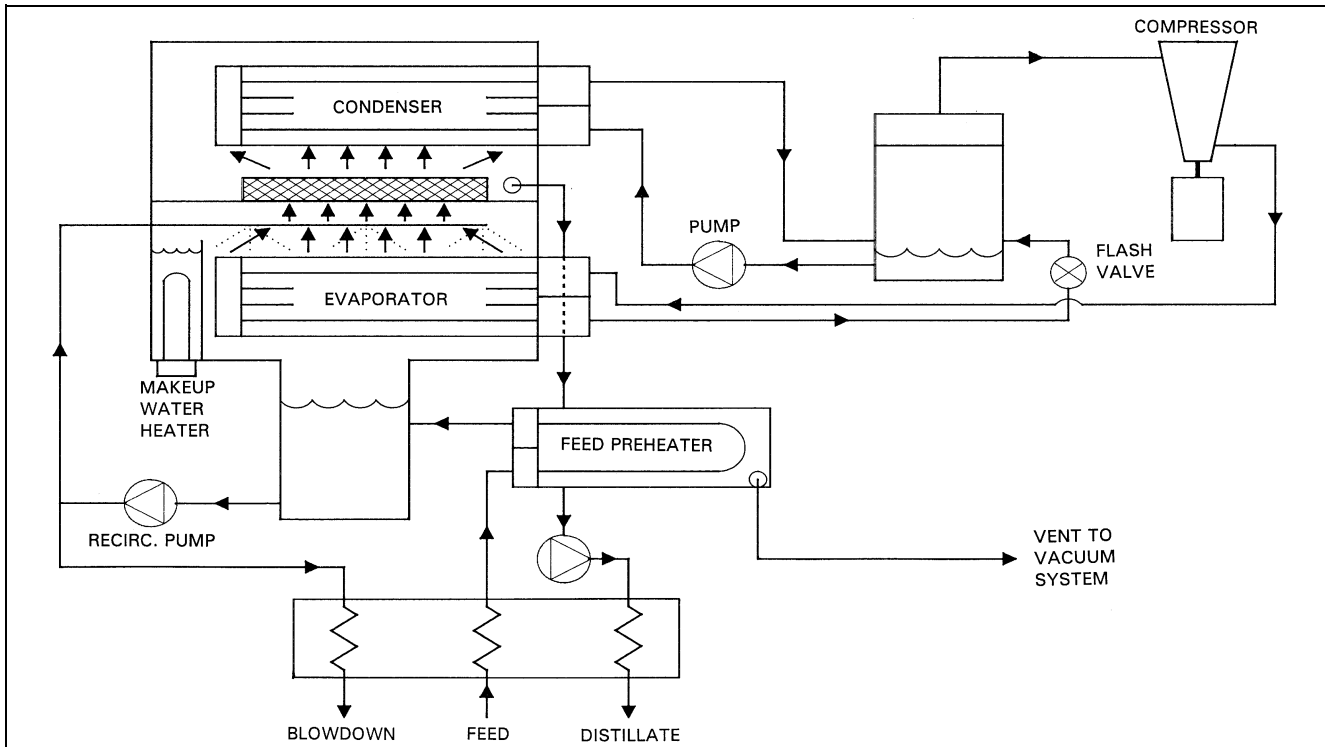

Fig. 14 Closed-Cycle Vapor Compression System

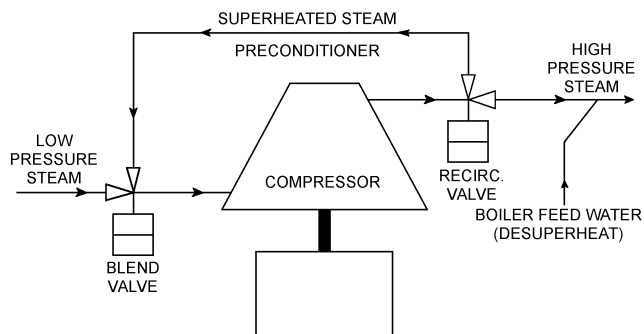

Fig. 15 Recompression of Boiler-Generated Process Steam

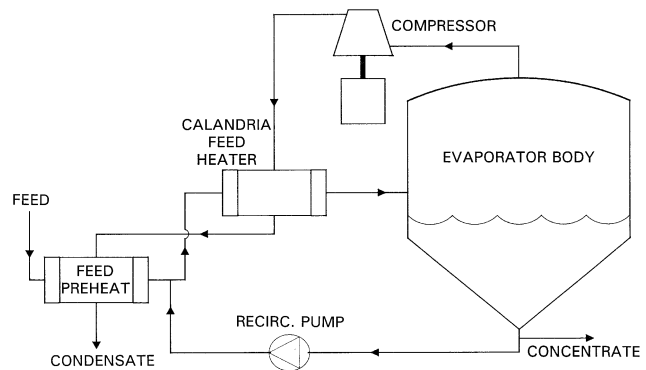

Fig. 16 Single-Effect Heat Pump Evaporator

Open-Cycle and Semi-Open-Cycle Heat Pump Systems

Open-cycle heat pump systems and **semi-open-cycle heat pump systems** use the process fluid to raise the temperature of the available heat energy by vapor compression, thus eliminating the need for chemical refrigerants. The most important class of applications is steam recompression. Compression can be provided with a mechanical compressor or by a thermocompression ejector driven by the required quantity of high-pressure steam. The three main controlling factors for this class of systems are vapor quality, boiling point elevation, and chemical makeup.

Recompression of boiler-generated process steam (Figure 15) has two major applications: (1) large facilities with substantial steam pressure drop due to line losses and (2) facilities with a considerable imbalance between steam requirements at low, medium, and high levels. Boiler-generated process steam usually conforms to cleanliness standards that ensure corrosion-free operation of the compression equipment. Evaluation of energy costs and steam

value can be complicated with these applications, dictating the use of analytical tools such as pinch technology.

Application of open-cycle heat pumps to evaporation processes is exceptionally important. Single-effect **evaporators** (Figure 16) are common when relatively small volumes of water and solid need to be separated. The most frequent applications are in the food and dairy industries. The overhead vapors of the evaporator are compressed, and thus heated, and piped to the system heater (i.e., calandria). The heat is transferred to the dilute solution, which is then piped to the evaporator body. Flashing occurs upon entry to the evaporator body, sending concentrate to the bottom and vapors to the top. System COPs reach 10 to 20, and long-term performance of the evaporator improves as less of the product (and thus less buildup) occurs in the calandria. Multiple-effect evaporators (Figure 17) employ the same basic principles, only on a much larger scale. They are usually applied in the paper and chemical industries.

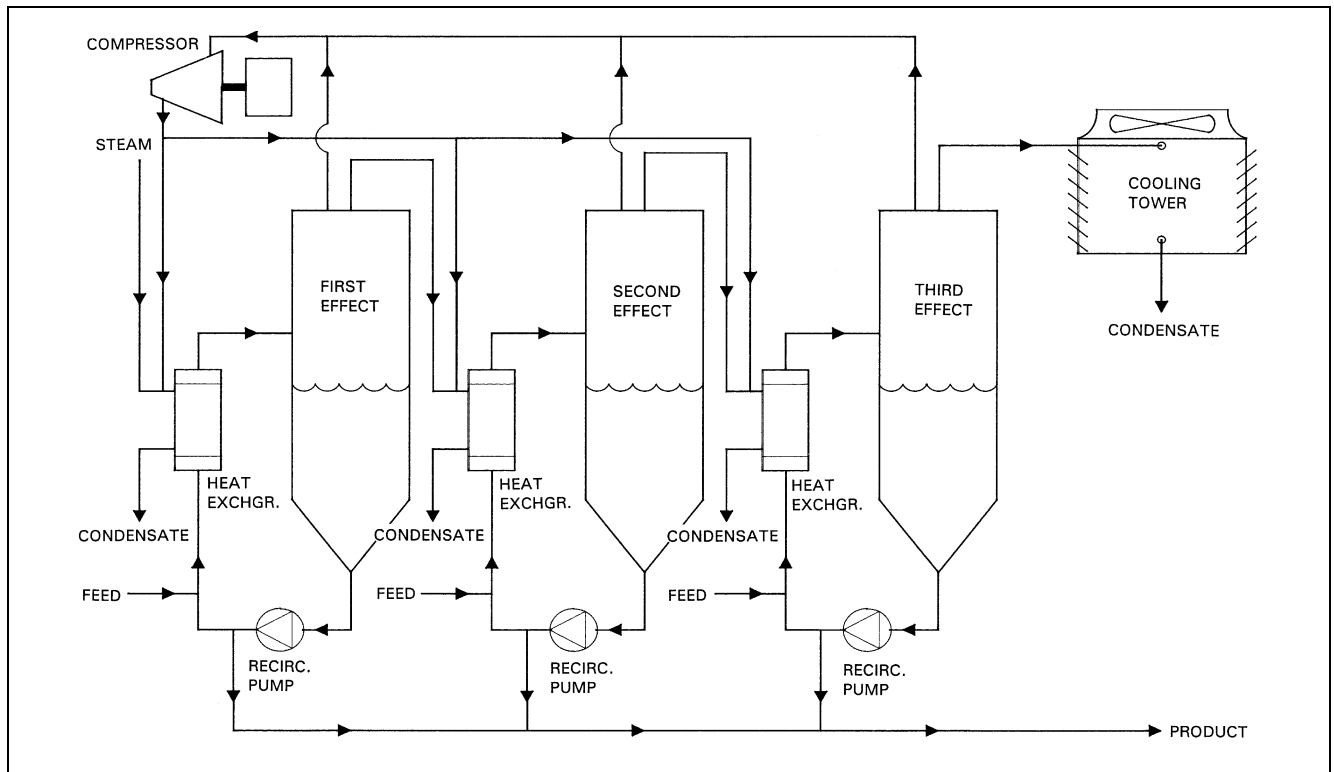

Fig. 17 Multiple-Effect Heat Pump Evaporator

The multiple evaporator bodies can be piped in series or in parallel. System COPs can exceed 30.

Application of open-cycle heat pumps to distillation processes (Figure 18) is similar to evaporation. However, compression of flammable gaseous compounds can be dangerous, so great care must be taken. The overhead vapors are compressed to a higher pressure and temperature, and then condensed in the reboiler. This eliminates the need for boiler steam in the reboiler and reduces overall energy consumption. As the pressure of the condensed vapor is reduced through the expansion valve, some of the liquid at a lower temperature is returned to the column as reflux, and the balance forms the overhead product, both as liquid and as vapor. Vapor is recycled as necessary. System COPs can reach 30 or 40.

Process emission-to-steam heat pump systems can be used for cooking, curing, and drying systems that operate with low-pressure saturated or superheated steam. The vapors from a cooking process, such as at a rendering plant, can be recovered to generate the steam required for cooking (Figure 19). The vapors are compressed with a screw compressor because noncondensable materials removed from the process by the vapor could erode or damage the reciprocating or centrifugal compressors. The compressed steam is supplied as the heat source to the cooker, and the steam condenses. The condensate is then supplied to a heat exchanger to heat process water. The noncondensables are usually scrubbed or incinerated, and the water is treated or discharged to a sewer.

The contaminants in some processes require the use of a semi-open-cycle heat pump (Figure 20). This system uses a heat exchanger, frequently called a reboiler, to recover heat from the stack gases. The reboiler produces low-pressure steam, which is compressed to the desired pressure and temperature. A clean-in-place (CIP) system may be used if the volume of contaminants is substantial.

Variable-speed drives can be specified with all these systems for closer, more efficient capacity control. Additional capacity for

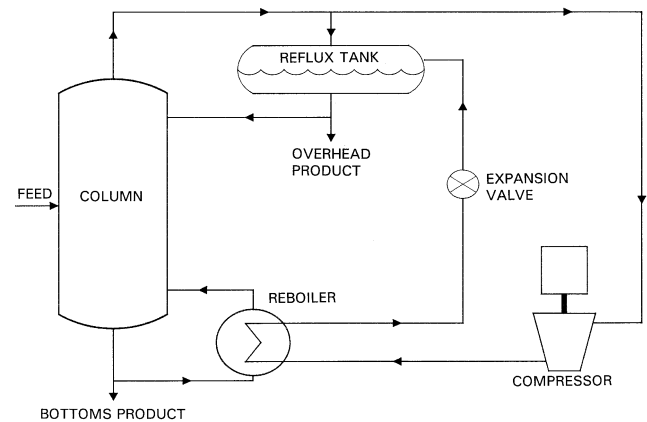

Fig. 18 Distillation Heat Pump System

emergencies can be made available by temporarily over-speeding the drive, while sizing for nominal operating conditions to retain optimal efficiency. Proper integration of heat pump controls and system controls is essential.

Heat Recovery Design Principles

The following basic principles should be applied when designing heat recovery systems:

- Use Second Law, pinch technology, or other thermodynamic analysis methods, especially for complex processes, before detailed design to ensure proper thermodynamic placement of the HRHP.
- Design for base-load conditions. Heat recovery systems are designed for reduced operating costs. Process scheduling and thermal storage (usually hot water) can be used for better system

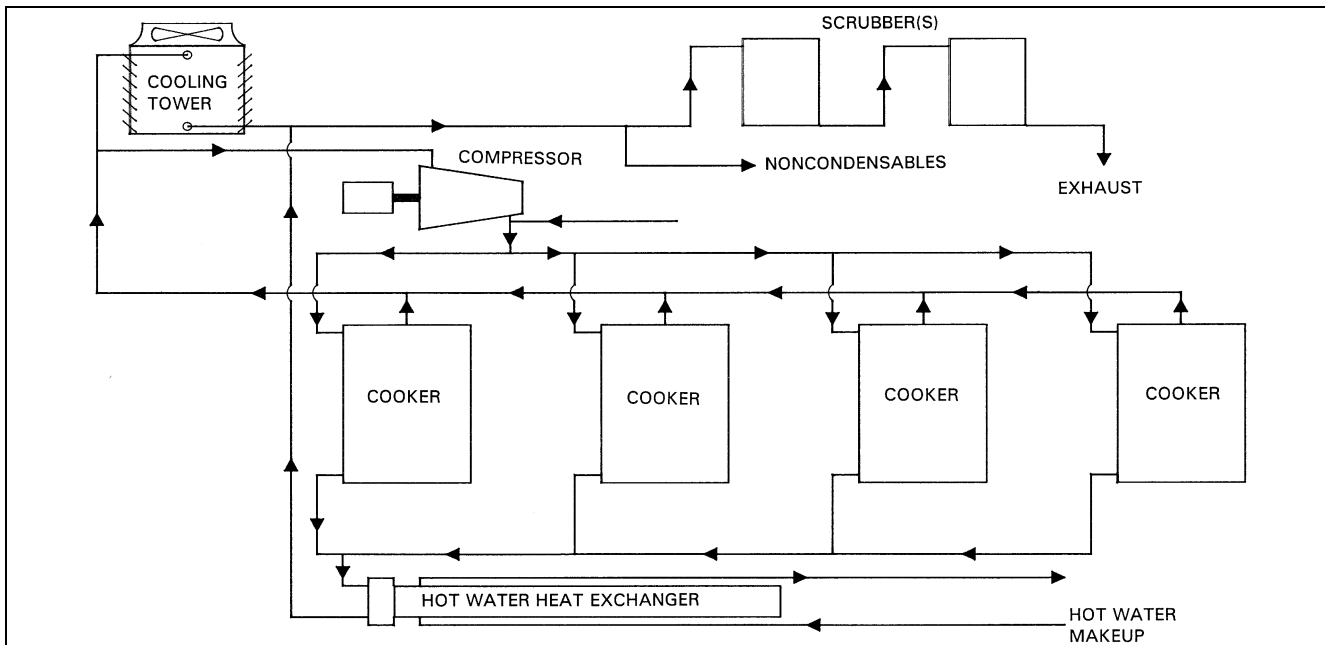

Fig. 19 Heat Recovery Heat Pump System in a Rendering Plant

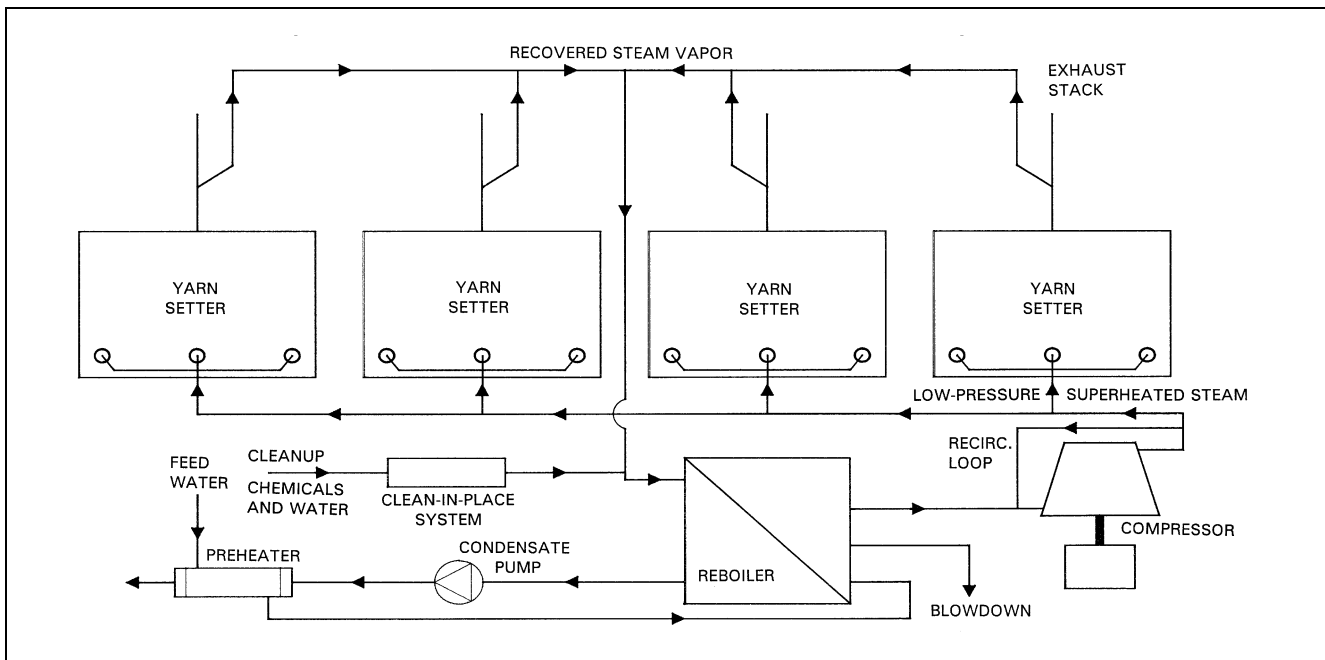

Fig. 20 Semi-Open Cycle Heat Pump in a Textile Plant

- balancing. Existing water heating systems can be used for peak load periods and for better temperature control.
- Exchange heat first, then pump the heat. If a heat exchanger is to provide the thermal work in a system, it should be used by itself. If additional cooling of the heat source stream and/or additional heating of the heat sink stream are needed, then a heat pump should be added.
 - Do not expect a heat pump to solve a design problem. A design problem such as an unbalanced refrigeration system may be exacerbated by the addition of a heat pump.

- Make a complete comparison of the heat exchanger system and the heat pump system. Compared to heat exchange alone, a heat pump system has additional first and operating costs. If feasible, heat exchange should be added to the front end of the heat pump system.
- Evaluate the cost of the heat displaced by the heat pump system. If the boiler operation is not changed, or if it makes the boiler less efficient, the heat pump may not be economical.
- Investigate standard fuel-handling and heat exchanger systems already in use in an industry before designing the heat pump.

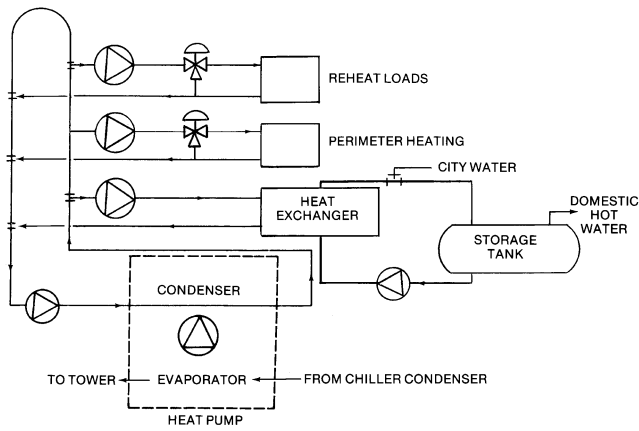

Fig. 21 Heat Recovery Heat Pump

- Measure the flow and temperature profile of both the heat source and heat sink over an extended period of time. The data may help prevent overestimating the requirements and economics of the system.
- Investigate future process changes that may affect the thermal requirements and/or availability of the system. Determine whether the plant is changing to a cold water cleanup system or changing a process to produce less effluent at lower temperatures.
- Design the system to give plant operators the same or better control. Thoroughly review manual versus automatic controls.
- Determine whether special material specifications are needed for handling any process flows. Obtain a chemical analysis for any flow of unknown makeup.
- Inform equipment suppliers of the full range of ambient conditions to which the equipment will be exposed and the expected loading requirements.

APPLIED HEAT RECOVERY SYSTEMS

WASTE HEAT RECOVERY

In many large buildings, internal heat gains require year-round chiller operation. The chiller condenser water heat is often wasted through a cooling tower. Figure 21 illustrates an HRHP installed in the water line from the chiller's condenser before rejection at the cooling tower. This arrangement uses the otherwise wasted heat to provide heat at the higher temperatures required for space heating, reheat, and domestic water heating.

Prudent design may dictate cascade systems with chillers in parallel or series. Custom components are available to meet a wide range of load and temperature requirements. The double-bundle condenser is most often used in this application. Figure 22 shows the basic configuration of this system, which makes heat available in the range of 100 to 130°F. The warm water is supplied as a secondary function of the heat pump and represents recovered heat.

Figure 23 shows a similar cycle, except that a storage tank has been added, enabling the system to store heat during occupied hours by raising the temperature of the water in the tank. During unoccupied hours, water from the tank is gradually fed to the evaporator providing load for the compressor and condenser that heats the building during off hours.

Figure 24 shows a heat transfer system capable of generating 130 to 140°F or warmer water whenever there is a cooling load, by cascading two refrigeration systems. In this configuration, Machine No. I can be considered as a chiller only and Machine No. II as a heating-only heat pump.

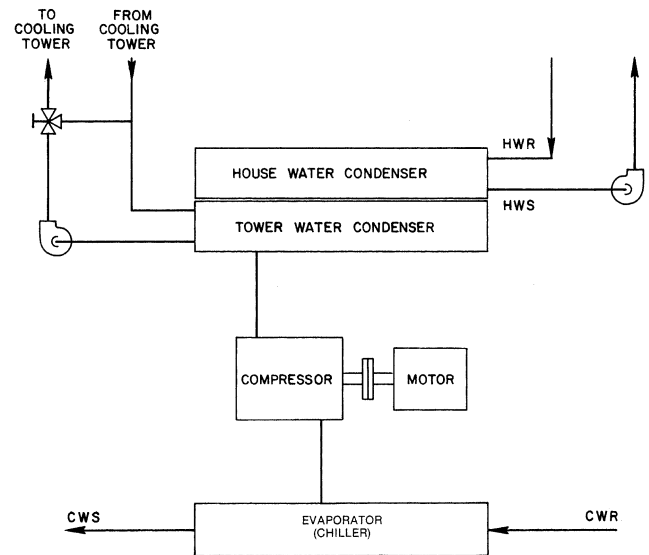

Fig. 22 Heat Recovery Chiller with Double-Bundle Condenser

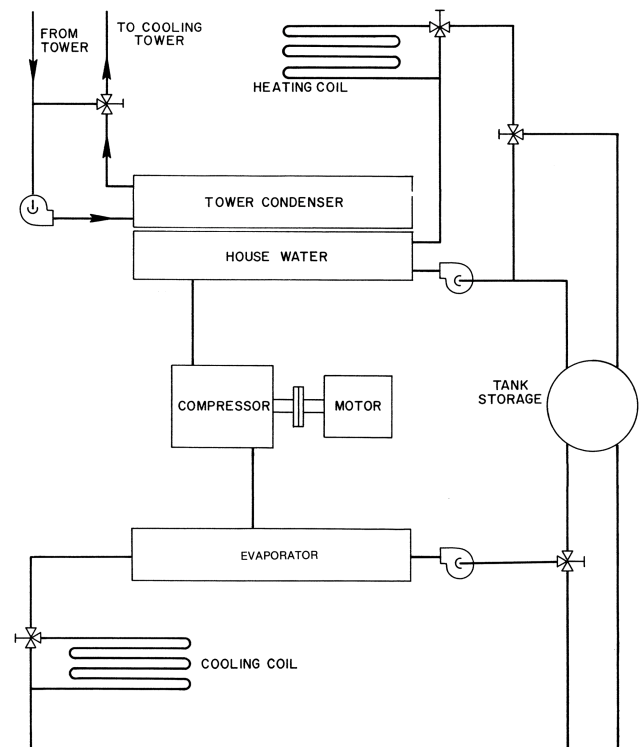

Fig. 23 Heat Recovery Chiller with Storage Tank

An indication of the magnitude of the recoverable heat in a modern multistory office building is shown in Figures 25, 26, and 27. Figures 25 and 26 show the gross heat loss and the internal heat gain of the exterior and interior zones during occupied periods. Figure 27 shows the total amount of heat available for recovery. Heat recovered from internal zones can be used to provide all or a portion of the heating requirements of the external zones. The excess recovered heat can be diverted to thermal storage for later use during unoccupied periods. During the occupied periods, no outside heat source or supplemental heat is needed at outdoor temperatures of 23°F or above for this hypothetical building.

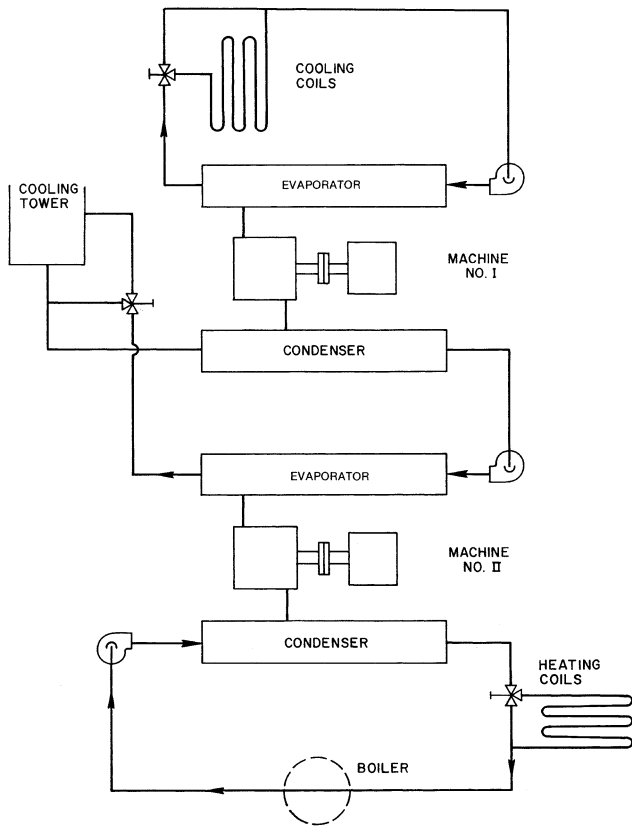

Fig. 24 Multistage (Cascade) Heat Transfer System

It must be understood that relative performances are indicated in these figures to illustrate general cases. Of course, each building will have parameters that differ from those of the building used for the figures.

WATER LOOP HEAT PUMP SYSTEMS

Description

A water loop heat pump (WLHP) system combines load transfer characteristics with multiple water-to-air heat pump units (Figure 28). Each zone, or space, has one or more water-to-air heat pumps. The units in both the building core and perimeter areas are connected hydronically with a common two-pipe system. Each unit cools conventionally, supplying air to the individual zone and rejecting the heat removed to the two-pipe system through its integral condenser. The excess heat gathered by the two-pipe system is expelled through a common heat rejection device. This device often includes a closed-circuit evaporative cooling tower with an integral spray pump. If and when some of the zones, particularly on the northern side of the building, require heat, the individual units switch (by means of reversing refrigerant valves) into the heating cycle. These units then extract heat from the two-pipe water loop, a relatively high-temperature source, that is totally or partially maintained by heat rejected from the condensers of the units that provide cooling to other zones. When only heating is required, all units are in the heating cycle and, consequently, an external heat input to the loop is needed to maintain the loop temperature. The water loop temperature is usually maintained in the range of 60 to 90°F and, therefore, seldom requires piping insulation.

Any number of water-to-air heat pumps may be installed in such a system. Water circulates through each unit via the closed loop.

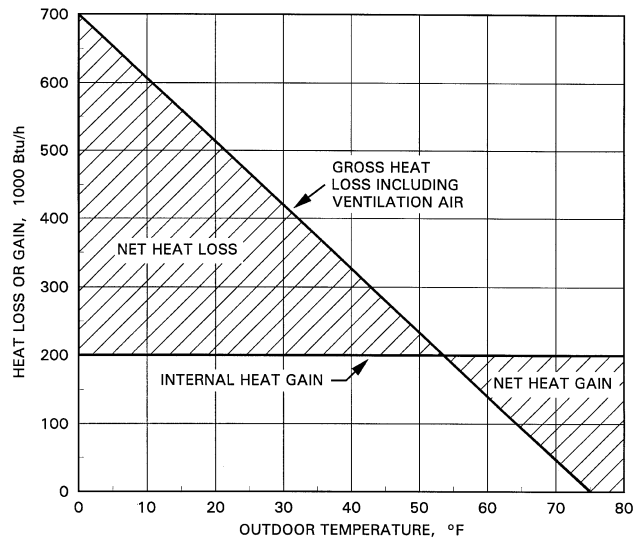

Fig. 25 Heat Loss and Heat Gain for Exterior Zones During Occupied Periods

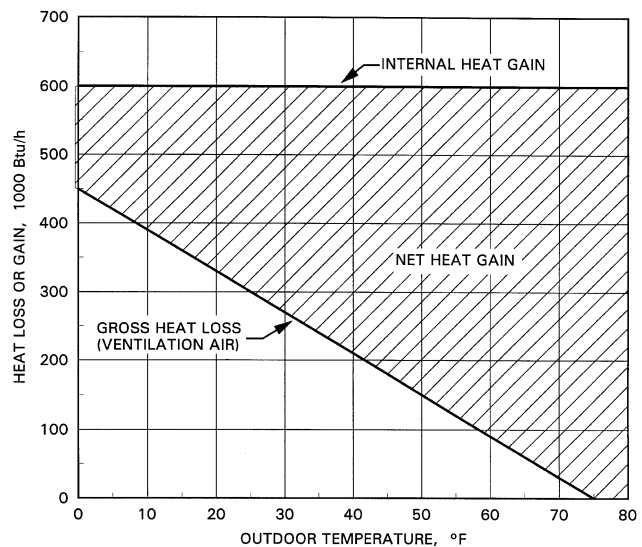

Fig. 26 Heat Loss and Heat Gain for Interior Zones During Occupied Periods

The water circuit usually includes two circulating pumps (one pump is 100% standby) and a means for adding and rejecting heat to and from the loop. Each heat pump can either heat or cool to maintain the comfort level in each zone.

Units operating in the heating mode extract heat from the circulated water, while units operating in the cooling mode reject heat to the water. Thus, the system recovers and redistributes heat, where needed. Unlike air-source heat pumps, heating output for this system does not depend on the outdoor temperature. The water loop conveys rejected heat, but a secondary heat source, typically a boiler, is usually provided.

Another version of the WLHP system uses a coil buried in the ground as a heat source and heat sink. This ground-coupled system does not normally need the boiler and cooling tower incorporated in conventional WLHP systems to keep the circulating water within acceptable temperature limits. However, ground-coupled heat pumps may operate at lower entering water (or antifreeze solution)

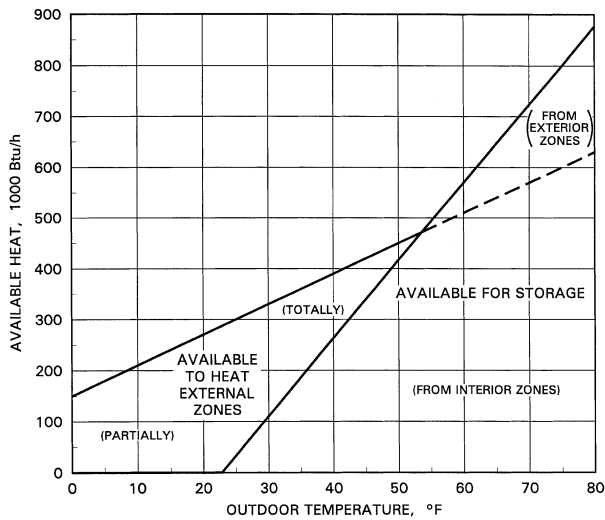

Fig. 27 Internal Heat Available for Recovery During Occupied Periods

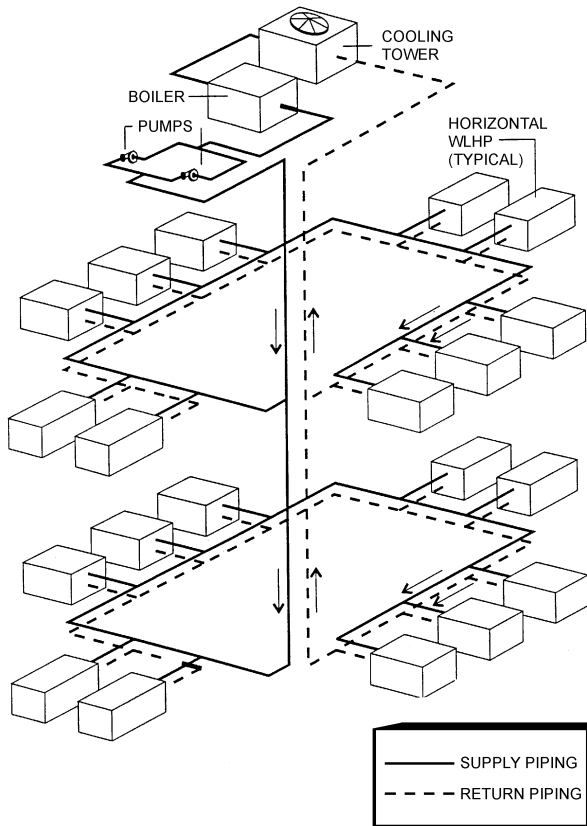

Fig. 28 Heat Recovery System Using Water-to-Air Heat Pumps in a Closed Loop

temperatures. Some applications may require a heat pump tolerant of entering water temperatures ranging from 25 to 110°F. In climates where air conditioning dominates, a cooling tower is sometimes combined with ground coupling to reduce overall installed costs.

Figure 29 illustrates a system with a storage tank and solar collectors. The storage tank in the condenser circuit can store excess

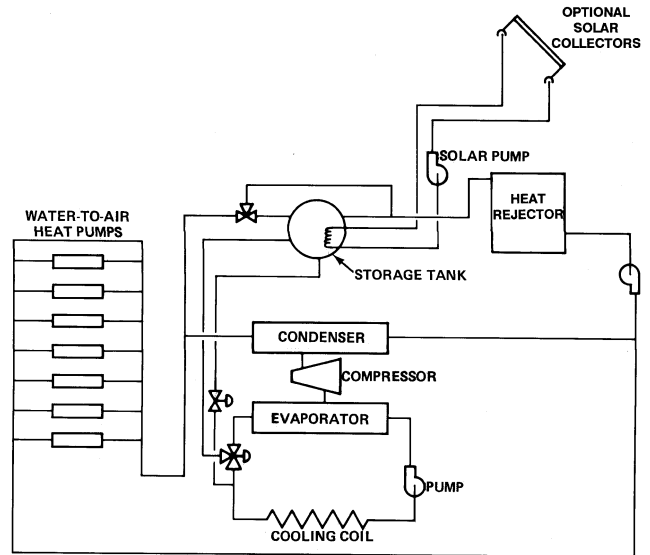

Fig. 29 Closed-Loop Heat Pump System with Thermal Storage and Optional Solar-Assist Collectors

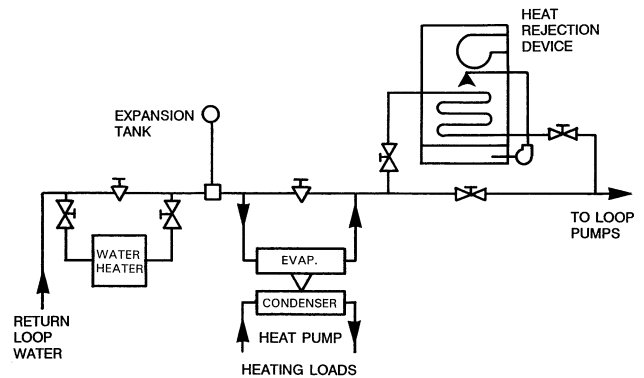

Fig. 30 Secondary Heat Recovery from WLHP System (Adapted from *Marketing the Industrial Heat Pump*, Edison Electric Institute 1989)

heat during occupied hours and provide heat to the loop during unoccupied hours. During this process of storing and draining heat from the tank, solar heat may also be added within the limitations of the temperatures of the condenser system. The solar collectors are more effective and efficient under these circumstances because of the temperature ranges involved.

For further heat reclaim, a water-to-water heat pump can be added in the closed water loop before the heat rejection device. This heat pump provides domestic hot water or elevates loop water temperatures in a storage tank so the water can be bled back into the loop when needed during the heating cycle. Figure 30 illustrates such a system.

Many facilities require large cooling loads (e.g., for interior zones, lights, people, business machines, computers, switchgear, and production machinery) that result in net loop heat rejection during all or most of the year, particularly during occupied hours. This rejection of waste heat often occurs while other heating loads in the facility (e.g., ventilation air, reheat, and domestic hot water) are using external purchased energy to supply heat. By including a secondary water-to-water heat pump in the system design (as shown in Figure 30), additional balanced heat recovery can be economically achieved. The secondary heat pump can effectively be used to

reclaim this otherwise rejected heat, raise its temperature, and use it to serve other heating loads, thus minimizing the use of purchased energy.

In another WLHP system variation, the building sprinkler system is used as part of the loop water distribution system.

Some aspects of the systems described in this section may be proprietary and should not be used without appropriate investigation.

Design Considerations

Water loop heat pump (WLHP) systems are used in many types of multiroom buildings. A popular application is in office buildings, where heat gains from interior zones can be redistributed to the perimeter during winter. Other applications include hotels and motels, schools, apartment buildings, nursing homes, manufacturing facilities, and hospitals. Operating costs for these systems are most favorable in applications with simultaneous heating and cooling requirements.

Unit Types. Chapter 45 describes various types and styles of units and the control options available.

Zoning. The WLHP system offers excellent zoning capability. Because equipment can be placed within the zones, future relocation of partitions can be accommodated with minimum duct changes. Some systems use heat pumps for perimeter zones and the top floor, with cooling-only units serving interior zones; all units are connected into the same loop water circuit.

Heat Recovery and Heat Storage. The WLHP system lends itself well to heat storage. Installations, such as schools, that cool most of the day in winter and heat at night make excellent use of heat storage. The water may be stored in a large tank in the closed-loop circuit ahead of the boiler. In this application, the loop temperature is allowed to build up to 90°F during the day. The stored water at 90°F can be used during unoccupied hours to maintain heat in the building, with the loop temperature allowed to drop to 60°F. The water heater (or boiler) would not be used until the loop temperature had dropped the entire 30°F. The storage tank operates as a flywheel to prolong the period of operation where neither heat makeup nor heat rejection is required.

Concealed Units. Equipment installed in ceiling spaces must have access for maintenance and servicing filters, control panels, compressors, and so forth. Adequate condensate drainage must be provided.

Ventilation. Outdoor air for ventilation may be (1) ducted from a ventilation supply system to the units or (2) drawn in directly through a damper into the individual units. To operate satisfactorily, the air entering the water-source heat pumps should be above 60°F. In cold climates, the ventilation air must be preheated. The quantity of ventilation air entering directly through individual units can vary greatly due to the stack effect, wind, and balancing difficulties.

Secondary Heat Source. The secondary heat source for heat makeup may be electric, gas, oil, ground, solar energy, and/or waste heat. Normally, a water heater or boiler is used; however, electric resistance heat in the individual heat pumps, with suitable controls, may also be used. The control may be an aquastat set to switch from heat pump to resistance heaters when the loop water approaches the minimum 60°F.

An electric boiler is readily controllable to provide 60°F outlet water and can be used directly in the loop. With a gas-fired or oil-fired combustion boiler, a heat exchanger may be used to transfer heat to the loop or, depending on the type of boiler used, a modulating valve may blend hot water from the boiler into the loop.

Solar or ground energy can supply part or all of the secondary heat. Water or antifreeze solution circulated through collectors can add heat to the system directly or indirectly via a secondary heat exchanger.

A building with night setback may need a supplementary heater boiler sized for the installed capacity, not the building heat loss, because the morning warm-up cycle may require every heat pump

to operate at full heating capacity until the building is up to temperature. In this case, based on a typical heating COP of 4.0 for a water-source heat pump, the boiler would be sized to provide about 75% of the total heating capacity of all water-source heat pumps installed in the building.

Heat Rejector Selection. A closed-loop circuit requires a heat rejector that is either a heat exchanger (loop water to cooling tower water), a closed-circuit evaporative cooler, or a ground coil. The heat rejector is selected in accordance with manufacturer's selection curves, using the following parameters:

- **Water flow rates.** Manufacturers' recommendations on water flow rates vary between 2 and 3 gpm per ton of installed cooling capacity. The lower flow rates are generally preferred in regions having a relatively low summer outdoor design wet-bulb temperature. In more humid climates, a higher flow rate allows a higher water temperature to be supplied from the heat rejector to the heat pumps, without a corresponding increase in temperature leaving the heat pumps. Thus, cooling tower or evaporative cooler size and cost are minimized without penalizing the performance of the heat pumps.
- **Water temperature range.** Range (the difference between the leaving and entering water temperatures at the heat rejector) is affected by heat pump cooling efficiency, water flow rate, and diversity. It is typically between 10 and 15°F.
- **Approach.** Approach is the difference between the water temperature leaving the cooler and the wet-bulb temperature of the outside air. The maximum water temperature expected in the loop supply is a function of the design wet-bulb temperature.
- **Diversity.** Diversity is the maximum instantaneous cooling load of the building divided by the installed cooling capacity:

$$D = Q_m / Q_i \quad (1)$$

where

- D = diversity
- Q_m = maximum instantaneous cooling load
- Q_i = total installed cooling capacity

Diversity times the average range of the heat pumps is the applied range of the total system (the rise through all units in the system and the drop through the heat rejector). For systems with a constant pumping rate regardless of load,

$$R_s = DR_p \quad (2)$$

where

- R_s = range of system
- R_p = average range of heat pumps

For systems with a variable pumping rate and with each pump equipped with a solenoid valve to start and stop water flow through the unit with compressor operation,

$$R_s \approx R_p \quad (3)$$

The average leaving water temperature of the heat pumps is the entering water temperature of the heat rejector. The leaving water temperature of the heat rejector is the entering water temperature of the heat pumps.

- **Winterization.** For buildings with some potential year-round cooling (e.g., office buildings), loop water may be continuously pumped through the heat rejector. This control procedure reduces the danger of freezing. However, it is important to winterize the heat rejector to minimize the heat loss.

In northern climates, the most important winterization step for evaporative coolers is the installation of a discharge air plenum

with positive-closure, motorized, ice-proof dampers. The entire casing that houses the tube bundle and the discharge plenum may be insulated. The sump, if outside the heated space, should be equipped with electric heaters. The heat pump equipment manufacturer's instructions will help in the selection and control of the heat rejector.

If sections of the water circuit will be exposed to freezing temperatures, the addition of an antifreeze solution should be considered. In a serpentine pipe circuit having no automatic valves that could totally isolate individual components, an antifreeze solution prevents bursting pipes, with minimal effect on system performance.

An open cooling tower with a separate heat exchanger is a practical alternative to the closed water cooler (Figure 31). An additional pump is required to circulate the tower water through the heat exchanger. In such an installation, where no tubes are exposed to the atmosphere, it may not be necessary to provide freeze protection on the tower. The sump may be indoors or, if outdoors, may be heated to keep the water from freezing. This arrangement allows the use of small, remotely located towers. Temperature control necessary for tower operation is maintained by a sensor in the water loop system controlling operation of the tower fan(s).

The combination of an open tower, heat exchanger, and tower pump frequently is lower in first cost than an evaporative cooler. In addition, operating costs are lower because no heat is lost from the loop in winter and, frequently, less power is required for the cooling tower fans.

Ductwork Layout. Often, a WLHP system has ceiling-concealed units, and the ceiling area is used as the return plenum. Troffered light fixtures are a popular means of returning air to the ceiling plenum.

The air supply from the heat pumps should be designed for quiet operation. Heat pumps connected to ductwork must be capable of overcoming external static pressure. The heat pump manufacturers' recommendations should be consulted for the maximum and minimum external static pressure allowable with each piece of equipment.

Piping Layout. Reverse-return piping should be used wherever possible with the WLHP system. This is particularly true where all units have essentially the same capacity. Balancing is then minimized except for each of the system branches. If direct-return piping is used, balancing the water flow is required at each individual heat pump. The entire system flow may circulate through the boiler and heat rejector in series. Water makeup should be at the constant pressure point of the entire water loop. Piping system design is similar to the secondary water distribution of air-and-water systems.

Pumping costs for a WLHP system can be significant. Because loads on the system vary considerably, variable-speed pumping should be considered. This requires an automatic valve at each heat

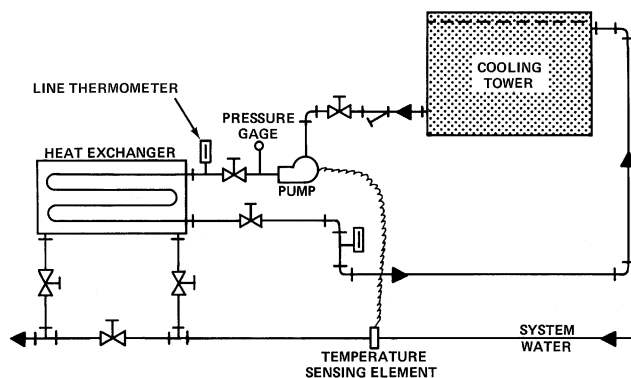

Fig. 31 Cooling Tower with Heat Exchanger

pump that allows water flow through the heat pump coil only during compressor operation.

Clean piping is vital to successful performance of the water-source heat pump system. The pipe should be clean when installed, kept clean during construction, and thoroughly cleaned and flushed upon completion of construction. Start-up water filters in the system bypass (pump discharge to suction) should be included on large, extensive systems.

Controls

The WLHP system has simpler controls than totally central systems. Each heat pump is controlled by a thermostat in the zone. There are only two centralized temperature control points: one to add heat when the water temperature approaches a prescribed lower temperature (typically about 60°F), and the other to reject heat when the water temperature approaches a prescribed upper temperature (typically about 90°F).

The boiler controls should be checked to be sure that outlet water is controlled at 60°F, because controls normally supplied with boilers are in a much higher range.

An evaporative cooler should be controlled by increasing or decreasing heat rejection capacity in response to the loop water temperature leaving the cooler. A reset schedule that operates the system at a lower water temperature (to take advantage of lower outdoor wet-bulb temperatures) can save energy when heat from the loop storage is not likely to be used.

Abnormal condition alarms typically operate as follows:

- Upon a fall in loop temperature to 50°F, initiate an alert. Open heat pump control circuits at 45°F.
- Upon a rise in loop temperature to 105°F, initiate an alert. Open heat pump control circuits at 110°F.
- Upon sensing insufficient system water flow, a flow switch initiates an alert and opens the heat pump control circuits.

An outside ambient control should be provided to prevent operation of the cooling tower sump pump at freezing temperatures.

Optional system control arrangements include the following:

- Night setback control
- Automatic unit start/stop, with after-hour restart as a tenant option
- Warm-up cycle
- Pump alternator control

Advantages of a WLHP System

- Affords opportunity for energy conservation by recovering heat from interior zones and/or waste heat and by storing excess heat from daytime cooling for nighttime or other heating uses.
- Allows recovery of solar energy at a relatively low fluid temperature where solar collector efficiency is likely to be greater.
- The building does not require wall penetrations to provide for the rejection of heat from air-cooled condensers.
- Provides environmental control in scattered occupied zones during nights or weekends without the need to start a large central refrigeration machine.
- Units are not exposed to outdoor weather, which allows installation in coastal and other corrosive atmospheres.
- Units have a longer service life than air-cooled heat pumps.
- Noise levels can be lower than those of air-cooled equipment because condenser fans are eliminated and the compression ratio is lower.
- Two-pipe boiler/chiller systems are potentially convertible to this system.
- The entire system is not shut down when a unit fails. However, loss of pumping capability, heat rejection, or secondary heating could affect the entire system.

- Energy usage by the heat pumps can be metered for each tenant. However, this metering would not include energy consumed by the central pump, heat rejector, or boiler.
- Total life-cycle cost of this system frequently compares favorably to that of central systems when considering installed cost, operating costs, and system life.
- Units can be installed as space is leased or occupied.

Limitations of a WLHP System

- Space is required for the boiler, heat exchangers, pumps, and heat rejector.
- Initial cost may be higher than for systems that use multiple unitary HVAC equipment.
- Reduced airflow can cause the heat pump to overheat and cut out. Therefore, periodic filter maintenance is imperative.
- Cleanliness of the piping loop must be maintained.

BALANCED HEAT RECOVERY SYSTEMS

Definition

In an ideal heat recovery system, all components work year-round to recover all the internal heat before adding external heat. Any excess heat is either stored or rejected. Such an idealized goal is identified as a balanced heat recovery system.

When the outdoor temperature drops significantly, or when the building is shut down (e.g., on nights and weekends), internal heat gain may be insufficient to meet the space heating requirements. Then, a balanced system provides heat from storage or an external source. When internal heat is again generated, the external heat is automatically reduced to maintain proper temperature in the space. There is a time delay before equilibrium is reached. The size of the equipment and the external heat source can be reduced in a balanced system that includes storage. Regardless of the system, a heat balance analysis establishes the merits of balanced heat recovery at various outdoor temperatures.

Outdoor air less than 55 to 65°F may be used to cool building spaces with an air economizer cycle. When considering this method of cooling, the space required by ducts, air shafts, and fans, as well as the increased filtering requirements to remove contaminants and the hazard of possible freeze-up of dampers and coils must be weighed against alternatives such as the use of deep row coils with antifreeze fluids and efficient heat exchange. Innovative use of heat pump principles may give considerable energy savings and more satisfactory human comfort than an air economizer. In any case, hot and cold air should not be mixed (if avoidable) to control zone temperatures because it wastes energy.

Heat Redistribution

Many buildings, especially those with computers or large interior areas, generate more heat than can be used for most of the year. Operating cost is kept to a minimum when the system changes over from net heating to net cooling at the break-even outdoor temperature at which the building heat loss equals the internal heat load. If heat is unnecessarily rejected or added to the space, the changeover temperature varies from the natural break-even temperature, and operating costs increase. Heating costs can be reduced or eliminated if excess heat is stored for later distribution.

Heat Balance Concept

The concept of ideal heat balance in an overall building project or a single space requires that one of the following takes place on demand:

- Heat must be removed.
- Heat must be added.
- Heat recovered must exactly balance the heat required, in which case heat should be neither added nor removed.

In small air-conditioning projects serving only one space, either cooling or heating satisfies the thermostat demand. If humidity control is not required, the operation is simple. Assuming both heating and cooling are available, the automatic controls will respond to the thermostat to supply either. A system should not heat and cool the same space simultaneously.

Multiroom buildings commonly require heating in some rooms and cooling in others. Optimum design considers the building as a whole and transfers excess internal heat from one area to another, as required, without introducing external heat that would require waste heat disposal at the same time. The heat balance concept is violated when this occurs.

Humidity control must also be considered. Any system should add or remove only enough heat to maintain the desired temperature and control the humidity. Large percentages of outdoor air with high wet-bulb temperatures, as well as certain types of humidity control, may require reheat, which could upset the desirable balance. Usually, humidity control can be obtained without upsetting the balance. When reheat is unavoidable, internally transferred heat from heat recovery should always be used to the extent it is available, before using an external heat source such as a boiler. However, the effect of the added reheat must be analyzed, because it affects the heat balance and may have to be treated as a variable internal load.

When a building requires heat and the refrigeration plant is not in use, dehumidification is not usually required and the outdoor air is dry enough to compensate for any internal moisture gains. This should be carefully reviewed for each design.

Heat Balance Studies

The following analytical examples illustrate situations that can occur in nonrecovery and unbalanced heat recovery situations. [Figure 32](#) graphically shows the major components that comprise the total air-conditioning load of a building. Values above the zero line are cooling loads, and values below the zero line are heating loads. On an individual basis, the ventilation and conduction loads cross the zero line, which indicates that these loads can be a heating or a cooling load, depending on outdoor temperature. The solar load and internal loads are always a cooling load and are, therefore, above the zero line.

[Figure 33](#) combines all the loads shown in [Figure 32](#). The graph is obtained by plotting the conduction load of a building at various outdoor temperatures, and then adding or subtracting the other loads at each temperature. The project load lines, with and without solar effect, cross the zero line at 16 and 30°F, respectively. These are the outdoor temperatures for the plotted conditions when the naturally created internal load exactly balances the loss.

As plotted, this heat balance diagram includes only the building loads with no allowance for additional external heat from a boiler or other source. If external heat is necessary because of system design, the diagram should include the additional heat.

[Figure 34](#) illustrates what happens when heat recovery is not employed. It is assumed that at a temperature of 70°F, heat from an external source is added to balance conduction through the skin of the building in increasing amounts down to the minimum outdoor temperature winter design condition. [Figure 34](#) also adds the heat required for the outdoor air intake. The outdoor air comprising part or all of the supply air must be heated from outdoor temperature to room temperature. Only the temperature range above the room temperature is effective for heating to balance the perimeter conduction loss.

These loads are plotted at the minimum outdoor winter design temperature, resulting in a new line passing through points A, D, and E. This line crosses the zero line at -35°F, which becomes the artificially created break-even temperature rather than 30°F, when not allowing for solar effect. When the sun shines, the added solar heat at the minimum design temperature would further drop the -35°F break-even temperature. Such a design adds more

heat than the overall project requires and does not employ balanced heat recovery to use the available internal heat. This problem is most evident during mild weather on systems not designed to take full advantage of internally generated heat year-round.

The following are two examples of situations that can be shown in a heat balance study:

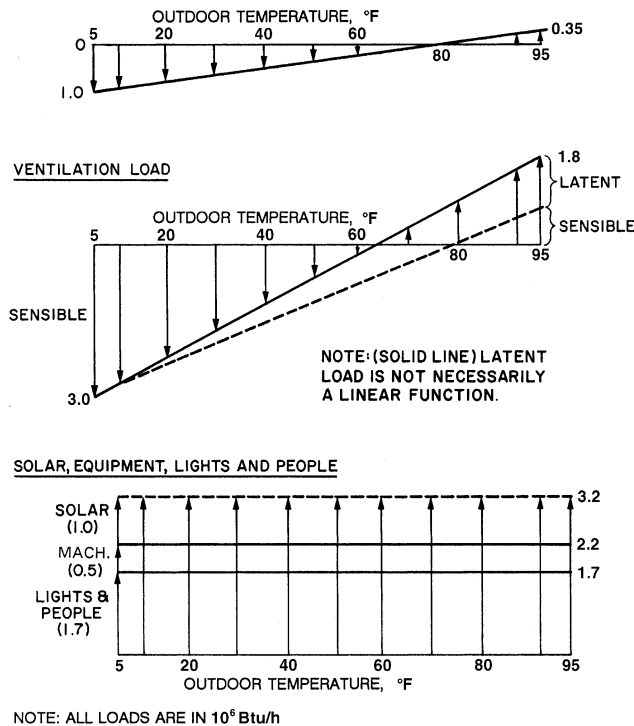

Fig. 32 Major Load Components

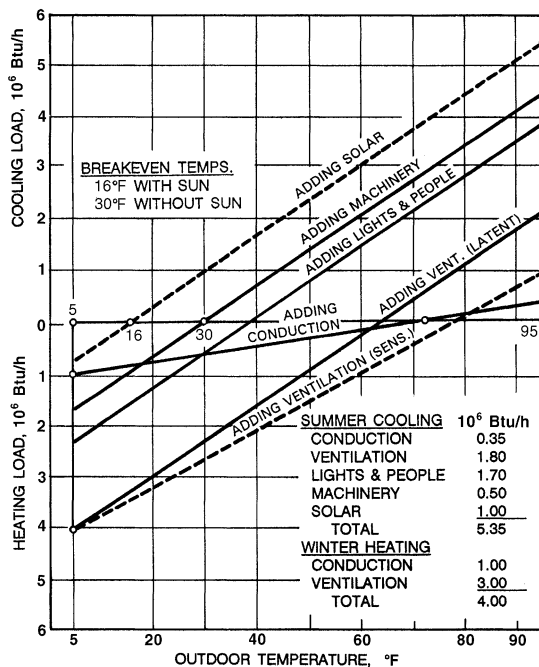

Fig. 33 Composite Plot of Loads in Figure 32 (Adjust for Internal Motor Heat)

1. As the outdoor air wet-bulb temperature drops, the total heat of the air falls. If a mixture of outdoor and recirculated air is cooled to 55°F in summer and the same dry-bulb temperature is supplied by an economizer cycle for interior space cooling in winter, there will be an entirely different result. As the outdoor wet-bulb temperature drops below 55°F, each unit volume of air introduced does more cooling. To make matters more difficult, this increased cooling is latent cooling, which requires the addition of latent heat to prevent too low a relative humidity, yet this air is intended to cool. The extent of this added external heat for free cooling is shown to be very large when plotted on a heat balance analysis at 0°F outside temperature.

Figure 34 is typical for many current non-heat-recovery systems. There may be a need for cooling, even at the minimum design temperature, but the need to add external heat for humidification can be eliminated by using available internal heat. When this asset is thrown away and external heat is added, operation is inefficient.

Some systems recover heat from exhaust air to heat the incoming air. When a system operates below its natural break-even temperature t_{be} such as 30 or 16°F (shown in Figure 33), the heat recovered from exhaust air is useful and beneficial. This assumes that only the available internal heat is used and that no supplementary heat is added at or above t_{be} . Above t_{be} , the internal heat is sufficient and any recovered heat would become excessive heat to be removed by more outdoor air or refrigeration.

If heat is added to a central system to create an artificial t_{be} of -35°F as in Figure 34, any recovered heat above -35°F requires an equivalent amount of heat removal elsewhere. If the project were in an area with a minimum design temperature of 0°F, heat recovery from exhaust air could be a liability at all times for the conditions stipulated in Figure 33. This does not mean that the value of heat recovered from exhaust air should be forgotten. The emphasis should be on recovering heat from exhaust air rather than on adding external heat.

2. A heat balance shows that insulation, double glazing, and so forth can be extremely valuable on some projects. However, these practices may be undesirable in certain regions during the heating season, when excess heat must usually be removed from large buildings. For instance, for minimum winter design temperatures of approximately 35 to 40°F, it is improbable that the interior core of a large office building will ever reach its break-even temperature. The temperature lag for shutdown periods,

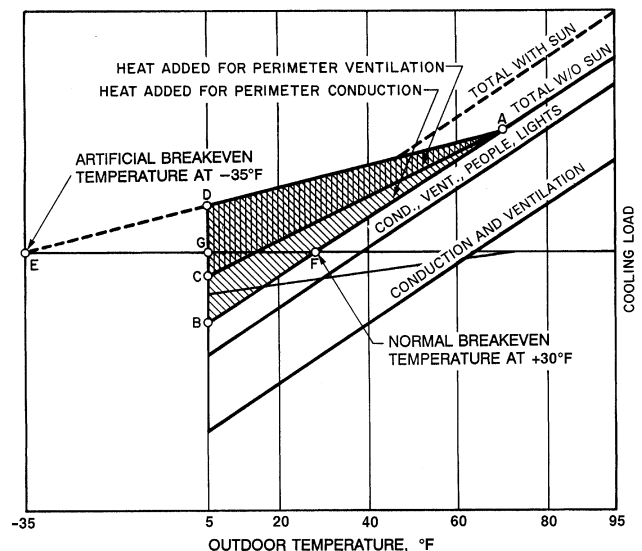

Fig. 34 Non-Heat-Recovery System

such as nights and weekends, at minimum design conditions could never economically justify the added cost of double-pane windows. Therefore, double-pane windows merely require the amount of heat saved to be removed elsewhere.

General Applications

A properly applied heat reclaim system automatically responds to make a balanced heat recovery. An example is a reciprocating water chiller with a hot-gas diverting valve and both a water-cooled and an air-cooled condenser. Hot gas from the compressor is rejected to the water-cooled condenser. This hot water provides internal heat as long as it is needed. At a predetermined temperature, the hot gas is diverted to the air-cooled condenser, rejecting excess heat from the total building system. Larger projects with centrifugal compressors use double-condenser chiller units, which are available from many manufacturers. For typical buildings, chillers normally provide hot water for space heating at 105 to 110°F.

Many buildings that run chillers all or most of the year reclaim some of the condenser heat to provide domestic hot water.

Designers should include a source of external heat for backup. The control system should ensure that backup heat is not injected unless all internal heat has been used. For example, if electric backup coils are in series with hot water coils fed from a hot water storage tank, they may automatically start when the system restarts after the building temperature has dropped to a night low-limit setting. An adjustable time delay in the control circuit gives the stored hot water time to warm the building before energizing the electric heat.

This type of heat reclaim system is readily adaptable to smaller projects using a reciprocating chiller with numerous air terminal units or a common multizone air handler. The multizone air handler should have individual zone duct heating coils and controls arranged to prevent simultaneous heating and cooling in the same zone.

Properly applied heat reclaim systems not only meet all space heating needs, but also provide hot water required for showers, food service facilities, and reheat in conjunction with dehumidification cycles.

Heat reclaim chillers or heat pumps should not be used with air-handling systems that have modulating damper economizer control. This free cooling may result in a higher annual operating cost than a minimum fresh air system with a heat reclaim chiller. Careful study shows whether the economizer cycle violates the heat balance concept.

Heat reclaim chillers or heat pumps are available in many sizes and configurations. Combinations include (1) centrifugal, reciprocating, and screw compressors; (2) single- and double-bundle condensers; (3) cascade design for higher temperatures (up to 220°F); and (4) air- or water-cooled, or both.

The designer can make the best selection after both a heating and cooling load calculation and a preliminary economic analysis, and with an understanding of the building, processes, operating patterns, and available energy sources.

The application of heat reclaim chillers or heat pumps ranges from simple systems with few control modes to complex systems having many control modes and incorporating two- or four-pipe circulating systems. Certain systems using double-bundle condensers and single-bundle condensers coupled with exterior closed-circuit coolers have been patented. Potential patent infringements should be checked early in the planning stage.

A successful heat recovery design depends on the performance of the total system, not just the chiller or heat pump. A careful and thorough analysis is often time-consuming and requires more design time than a nonrecovery system. The balanced heat recovery concept should guide all phases of planning and design, and the effects of economic compromise should be studied. There may be little difference between the initial cost (installed cost) of a heat recovery system and a nonrecovery system, especially in larger projects. Also, in view of energy costs, life-cycle analysis usually shows dramatic savings when using balanced heat recovery.

Multiple Buildings

A multiple-building complex is particularly suited to heat recovery. Variations in occupancy and functions provide an abundance of heat sources and uses. Applying the balanced heat concept to a large multibuilding complex can result in large energy savings. Each building captures its own total heat by interchange. Heat rejected from one building could possibly heat adjacent buildings.

BIBLIOGRAPHY

- ASHRAE. 1989. Heat recovery. *Technical Data Bulletin* 5(6).
- Ashton, G. J., H.R. Cripps, and H.D. Spriggs. 1987. Application of "pinch" technology to the pulp and paper industry. *Tappi Journal* (August):81-85.
- Becker, F.E. and A.I. Zakak. 1985. Recovering energy by mechanical vapor recompression. *Chemical Engineering Progress* (July):45-49.
- Bose, J.E., J.D. Parks, and F.C. McQuiston. 1985. Design/data manual for closed-loop ground-coupled heat pump systems. ASHRAE.
- Cane, R.L.D., S.B. Clernes, and D.A. Forgas. 1994. Heat recovery heat pump operating experiences. *ASHRAE Transactions* 100(2):165-72.
- Edison Electric Institute. 1989. *Marketing the industrial heat pump*. Washington, D.C.
- Ekroth, I.A. 1979. Thermodynamic evaluation of heat pumps working with high temperatures. *Proceedings of the Inter-Society Energy Conversion Engineering Conference* 2:1713-19.
- Eley Associates. 1992. *Water-loop heat pump systems, Volume 1: Engineering design guide*. Electric Power Research Institute, Palo Alto, CA.
- EPRI. 1984. Heat pumps in distillation processes. *Report No. EM-3656*. Electric Power Research Institute, Palo Alto, CA.
- EPRI. 1986. Heat pumps in evaporation processes. *Report No. EM-4693*. Electric Power Research Institute, Palo Alto, CA.
- EPRI. 1988. Industrial heat pump manual. *Report No. EM-6057*. Electric Power Research Institute, Palo Alto, CA.
- EPRI. 1989. Heat pumps in complex heat and power systems. *Report No. EM-4694*. Electric Power Research Institute, Palo Alto, CA.
- IEA. 1992. *Heat Pump Centre Newsletter* 10(1). International Energy Agency Heat Pump Centre, Sittard, The Netherlands.
- IEA. 1993. *Heat Pump Centre Newsletter* 11(1).
- Karp, A. 1988. Alternatives to industrial cogeneration: A pinch technology perspective. Presented at the International Energy Technology Conference (IETC), Houston, TX.
- Linnhoff, B. and G.T. Polley. 1988. General process improvement through pinch technology. *Chemical Engineering Progress* (June):51-58.
- Mashimo, K. 1992. Heat pumps for industrial process and district heating. Annual Meeting of International Users Club of Absorption Systems, Thisted, Denmark.
- Oil and Gas Journal. 1988. Refiners exchange conservation experiences. *Oil and Gas Journal* (May 23).
- Phetteplace, G.E. and H.T. Ueda. 1989. Primary effluent as a heat source for heat pumps. *ASHRAE Transactions* 95(1):141-46.
- Pucciano, F.J. 1995. Heat recovery in a textile plant. *IEA Heat Pump Centre Newsletter* 13(2):34-36.
- Tjoe, T.N. and B. Linnhoff. 1986. Using pinch technology for process retrofit. *Chemical Engineering* (April 28):47-60.
- Zimmerman, K.H., ed. 1987. Heat pumps—Prospects in heat pump technology and marketing. *Proceedings of the 1987 International Energy Agency Heat Pump Conference*, Orlando, FL.