

CONDENSER WATER SYSTEMS

<i>Once-Through City Water Systems</i>	13.1
<i>Open Cooling Tower Systems</i>	13.1
<i>Low-Temperature (Water Economizer) Systems</i>	13.3
<i>Closed-Circuit Evaporative Coolers</i>	13.3
<i>Overpressure due to Thermal Fluid Expansion</i>	13.3

CONDENSER water systems for refrigeration processes are classified as (1) once-through systems, such as city water systems; or (2) recirculating or cooling tower systems.

ONCE-THROUGH CITY WATER SYSTEMS

Figure 1 shows a water-cooled condenser using city water. The return is run higher than the condenser so that the condenser is always full of water. Water flow through the condenser is modulated by a control valve in the supply or discharge line, usually actuated from condenser head pressure to (1) maintain a constant condensing temperature with load variations and (2) close when the refrigeration compressor turns off. City water systems should always include approved backflow prevention devices and open (air gap) drains. When more than one condenser is used on the same circuit, individual control valves are used.

Once-through city water systems are discouraged in most localities because of the waste of city water and the burden on the sewage or wastewater system. Some localities allow their use as a standby or emergency condenser water system for critical refrigeration needs such as for computer rooms, research laboratories, or critical operating room or life support machinery.

Piping materials for these systems are generally nonferrous, usually copper but sometimes high-pressure plastic since corrosion-protective chemicals cannot be used. Scaling can be a problem with higher temperature condensing surfaces in locations in which the water has a relatively high calcium content. In these applications, mechanically cleanable straight tubes should be used.

Piping should be sized according to the principles outlined in [Chapter 35 of the ASHRAE Handbook—Fundamentals](#), with velocities of 5 to 10 fps for design flow rates. A pump is not required where city water is used. **Well water** can be used in lieu of city water, connected on the service side of the pumping/pressure control system. Since most well water has high calcium content, scaling on the condenser surfaces can be a problem.

OPEN COOLING TOWER SYSTEMS

Open systems are those in which there are at least two points of interface between the system water and the atmosphere; they require a different approach to hydraulic design, pump selection, and sizing than do closed hot water and chilled water systems. Some heat conservation systems rely on a split condenser heating system that includes a two-section condenser. One section of the condenser supplies heat for closed-circuit heating or reheat systems; the other section serves as a heat rejection circuit, which is an open system connected to a cooling tower.

In selecting a pump for a cooling tower/condenser water system, consideration must be given to the static head and the system friction loss. The pump inlet must have an adequate net positive suction head (see [Chapter 39](#)). In addition, continuous contact with

The preparation of this chapter is assigned to TC 6.1, Hydronic and Steam Equipment and Systems.

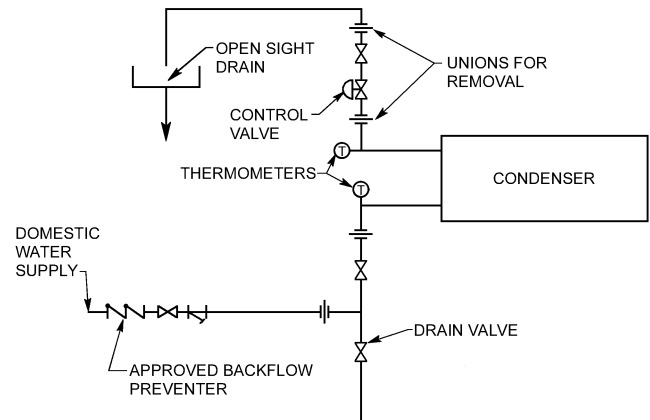

Fig. 1 Condenser Connections for Once-Through City Water System

air introduces oxygen into the water and concentrates minerals that can cause scale and corrosion on a continuing basis. Fouling factors and an increased pressure drop caused by aging of the piping must be taken into account in the condenser piping system design (see [Chapter 35 of the ASHRAE Handbook—Fundamentals](#)).

The required water flow rate depends on the refrigeration unit used and on the temperature of the available condenser water. Cooling tower water is available for return to the condenser at a temperature several degrees above the design wet-bulb temperature, depending on tower performance. An approach of 7°F to the design wet-bulb temperature is frequently considered an economically sound design. In city, lake, river, or well water systems, the maximum water temperature that occurs during the operating season must be used for equipment selection and design flow rates and temperature ranges.

The required flow rate through a condenser may be determined with manufacturers' performance data for various condensing temperatures and capacities. With air conditioning refrigeration applications, a return or leaving condenser water temperature of 95°F is considered standard practice. If economic feasibility analyses can justify it, higher leaving water temperatures may be used.

Figure 2 shows a typical cooling tower system for a refrigerant condenser. Water flows to the pump from the tower basin or sump and is discharged under pressure to the condenser and then back to the tower. When it is desirable to control condenser water temperature or maintain it above a predetermined minimum, water is diverted through a control valve directly back to the tower basin.

Piping from the tower sump to the pump requires some precautions. The sump level should be above the top of the pump casing for positive prime, and piping pressure drop should be such that there is always adequate net positive suction head on the pump. All piping must pitch up to the tower basin, if possible, to eliminate air pockets.

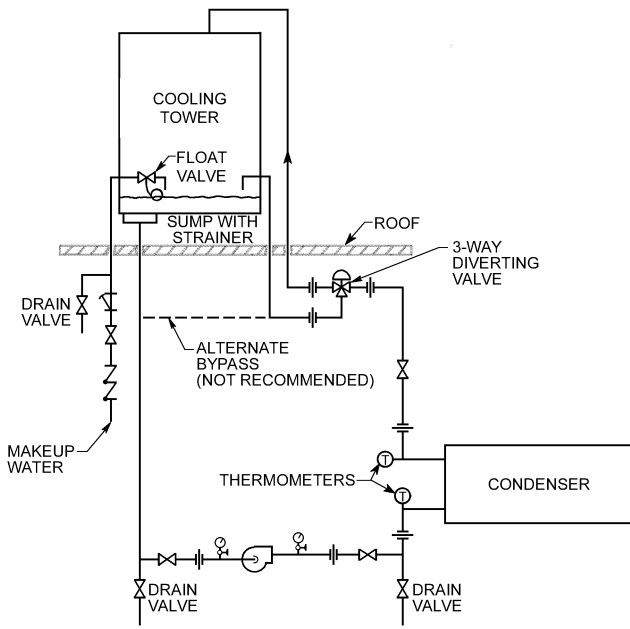

Fig. 2 Cooling Tower Piping System

If used, suction strainers should be equipped with inlet and outlet gages to indicate when cleaning is required. In-line pipe strainers are not recommended for cooling tower systems because they tend to become blocked and turn into a reliability problem in themselves. Many designers depend on large mesh screens in the tower sump and condenser heads designed with settling volumes to remove particulate matter. If a strainer is deemed necessary, two-large capacity basket strainers, installed in parallel such that they can be alternately put into service and valved out for cleaning, are recommended.

Air and Vapor Precautions

Both vapor and air can create serious problems in open cooling tower systems. Water vaporizes in the pump impeller if adequate net positive suction head is not available. When this occurs, the pump loses capacity, and serious damage to the impeller can result. Equally damaging vaporization can occur in other portions of the system where the pressure in the pipe can drop below the vapor pressure at the temperature of the water. On shutdown, these very low pressures can result from a combination of static pressure and momentum. Vaporization is often followed by an implosion, which causes destructive water hammer. To avoid this problem, all sections of the piping system except the return line to the upper tower basin should be kept below the basin level. When this cannot be achieved, a thorough dynamic analysis of the piping system must be performed for all operating conditions, and a soft start and stop control such as a variable-frequency drive on the pump motor is recommended as an additional precaution.

Air release is another characteristic of open condenser water systems that must be addressed. Since the water/air solution in the tower basin is saturated at atmospheric pressure and cold water basin temperature, the system should be designed to maintain the pressure at all points in the system sufficiently above atmospheric that no air will be released in the condenser or in the piping system (see [Figure 2](#) and [Figure 3](#) in [Chapter 12](#)).

Another cause of air in the piping system is “vortexing” at the tower basin outlet. This can be avoided by ensuring that the maximum flow does not exceed that recommended by the tower manufacturer. The release of air in condenser water systems is the major cause of corrosion, and it causes decreased pump flow (similar to

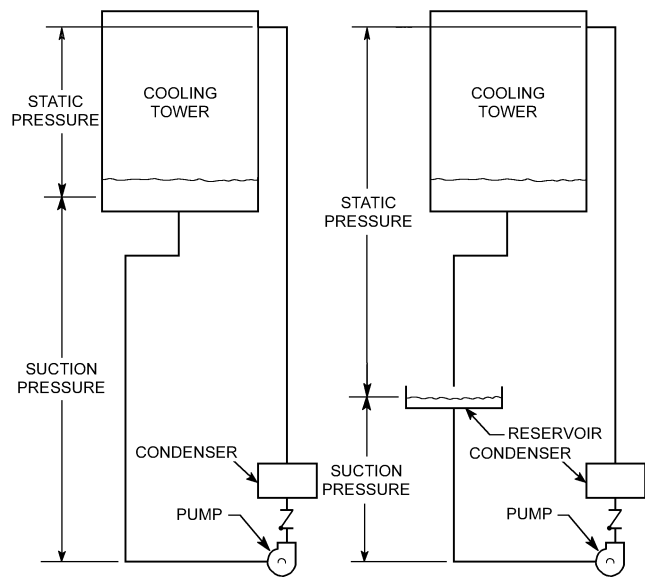

Fig. 3 Schematic Piping Layout Showing Static and Suction Head

cavitation), water flow restrictions in some piping sections, and possible water hammer.

Piping Practice

The elements of required pump head are illustrated in [Figure 3](#). Because there is an equal head of water between the level in the tower sump or interior reservoir and the pump on both the suction and discharge sides, these static heads cancel each other and can be disregarded.

The elements of pump head are (1) static head from tower sump or interior reservoir level to the tower header, (2) friction loss in suction and discharge piping, (3) pressure loss in the condenser, (4) pressure loss in the control valves, (5) pressure loss in the strainer, and (6) pressure loss in the tower nozzles, if used. Added together, these elements determine the required pump total dynamic head.

Normally, piping is sized for water velocities between 5 and 12 fps. Refer to [Chapter 35 of the ASHRAE Handbook—Fundamentals](#), for piping system pressure losses. Friction factors for 15-year-old pipe are commonly used. Manufacturers’ data contain pressure drops for the condenser, cooling tower, control valves, and strainers.

If multiple cooling towers are to be connected, the piping should be designed so that the pressure loss from the tower to the pump suction is *exactly* equal for each tower. Additionally, large equalizing lines or a common reservoir can be used to assure the same water level in each tower. However, for reliability and ease of maintenance, multiple basins are often preferred.

Evaporation in a cooling tower concentrates the dissolved solids in the circulating water. This concentration can be limited by discharging a portion of the water as overflow or blowdown.

Makeup water is required to replace the water lost by evaporation, blowdown, and drift. Automatic float valves or level controllers are usually installed to maintain a constant water level.

Water Treatment

Water treatment is necessary to prevent scaling, corrosion, and biological fouling of the condenser and circulating system. The extent and nature of the treatment depends on the chemistry of the available water and on the system design characteristics. On large

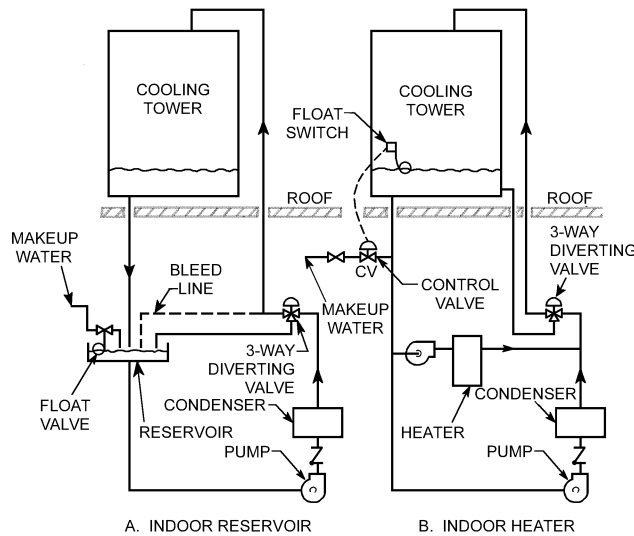

Fig. 4 Cooling Tower Piping to Avoid Freeze-Up

systems, fixed continuous-feeding chemical treatment systems are frequently installed in which chemicals, including acids for pH control, must be diluted and blended and then pumped into the condenser water system. Corrosion-resistant materials may be required for surfaces that come in contact with these chemicals. In the design of the piping system, provisions for feeding the chemicals, blow-downs, drains, and testing must be included. For further information on water treatment, refer to [Chapter 36](#) of this volume and [Chapter 48 of the ASHRAE Handbook—Applications](#).

Freeze Protection

Outdoor piping must be protected or drained when a tower operates intermittently during cold weather. The most satisfactory arrangement is to provide an indoor receiving tank into which the cold water basin drains by gravity as shown in [Figure 4A](#). The makeup, overflow, and pump suction lines are then connected to the indoor reservoir tank rather than to the tower basin.

A control sequence for the piping arrangement of [Figure 4A](#) with rising water temperature would be as follows: A temperature sensor measures the temperature of the water leaving the indoor sump. As the temperature starts to rise, the diverting valve begins directing some of the water over the tower. After the water is in full flow over the tower, and the temperature continues to rise above set point, the fan is started on low speed, with the speed increasing until the water temperature reaches set point. With falling water temperature, the opposite sequence occurs.

Tower basin heaters or heat exchangers connected across the supply and return line to the tower can also be selected. Steam or electric basin heaters are most commonly used. An arrangement incorporating an indoor heater is shown in [Figure 4B](#).

LOW-TEMPERATURE (WATER ECONOMIZER) SYSTEMS

When open cooling tower systems are used for generating chilled water directly, through an indirect heat exchanger such as a plate frame heat exchanger, or with a chiller thermocycle circuit, the bulk water temperature is such that there can be icing on or within the cooling tower, with destructive effects. The piping circuit precautions are similar to those described in the section on Open Cooling Tower Systems, but they are much more critical. For precautions in protecting cooling towers from icing damage, see [Chapter 36](#).

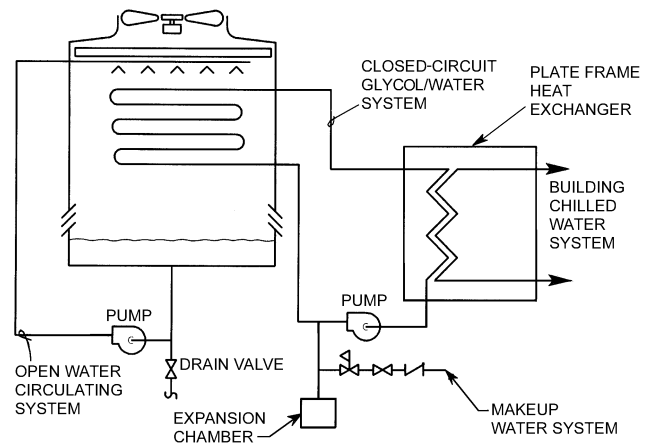

Fig. 5 Closed-Circuit Cooler System

Water from open cooling tower systems should not be piped directly through cooling coils, unitary heat pump condensers, or plate frame heat exchangers unless the water is first filtered through a high-efficiency filtering system and the water treatment system is managed to carefully minimize the dissolved solids. Even with these precautions, cooling coils should have straight tubes arranged for visual inspection and mechanical cleaning; unitary heat pumps should be installed for easy removal and replacement; and plate frame heat exchangers should be installed for ready accessibility for disassembly and cleaning.

CLOSED-CIRCUIT EVAPORATIVE COOLERS

Because of the potential for damaging freezing of cooling towers, some designers prefer to use closed-circuit evaporative/dry coolers for water economizer chilled water systems. There are many different configurations of these systems, one of which is shown in [Figure 5](#). The open water is simply recirculated from the basin to the sprays of the evaporative cooler, and the cooling water system is a closed hydronic system usually using a glycol-water mixture for freeze protection. The open water system is then drained in freezing weather and the cooling heat exchanger unit is operated as a dry heat exchanger. This type of system in some configurations can be used to generate chilled water through the plate frame heat exchanger shown or to remove heat from a closed heat pump circuit. The glycol circuit is generally not used directly either for building cooling or for the heat pump circuit because of the economic penalty of the extensive glycol system. The closed circuit is designed in accordance with the principles and procedures described in [Chapter 12](#).

OVERPRESSURE DUE TO THERMAL FLUID EXPANSION

When open condenser water systems are used at low temperatures for winter cooling, special precautions should be taken to prevent damaging overpressurization due to thermal expansion. This phenomenon has been known to cause severe damage when a section of piping containing water at a lower temperature than the surrounding space is isolated while cold. This isolation could be intentional, such as isolation by two service valves, or it could be as subtle as a section of piping isolated between a check valve and a control valve. If such an isolation occurs when water at 45°F is in a 1 in. pipe passing through a 75°F space, [Figure 28 in Chapter 12](#) reveals that the pressure would increase by 815 psi, which would be destructive to many components of most condenser water systems. Refer to the section on Other Design Considerations in [Chapter 12](#) for a discussion on this phenomenon.