

RESIDENTIAL IN-SPACE HEATING EQUIPMENT

<u>GAS IN-SPACE HEATERS</u>	29.1	<u>ELECTRIC IN-SPACE HEATERS</u>	29.4
<u>Controls</u>	29.2	<u>Radiant Heating Systems</u>	29.4
<u>Vent Connectors</u>	29.3	<u>SOLID-FUEL IN-SPACE HEATERS</u>	29.4
<u>Sizing Units</u>	29.3	<u>Fireplaces</u>	29.4
<u>OIL AND KEROSENE IN-SPACE HEATERS</u>	29.3	<u>Stoves</u>	29.5
		<u>GENERAL INSTALLATION PRACTICES</u>	29.6

IN-SPACE heating equipment differs from central heating in that fuel is converted to heat in the space to be heated. In-space heaters may be either permanently installed or portable and may transfer heat by a combination of radiation, natural convection, and forced convection. The energy source may be liquid, solid, gaseous, or electric.

GAS IN-SPACE HEATERS

Room Heaters

A **vented circulator room heater** is a self-contained, freestanding, nonrecessed gas-burning appliance that furnishes warm air directly to the space in which it is installed, without ducting (Figure 1). It converts the energy in the fuel gas to convected and radiant heat without mixing flue gases and circulating heated air by transferring heat from flue gases to a heat exchanger surface.

A **vented radiant circulator** is equipped with high-temperature glass panels and radiating surfaces to increase radiant heat transfer. Separation of flue gases from circulating air must be maintained. Vented radiant circulators range from 10,000 to 75,000 Btu/h.

Gravity-vented radiant circulators may also have a circulating air fan, but they perform satisfactorily with or without the fan. Fan-type vented radiant circulators are equipped with an integral circulating air fan, which is necessary for satisfactory performance.

Vented room heaters are connected to a vent, chimney, or single-wall metal pipe venting system engineered and constructed to develop a positive flow to the outside atmosphere. Room heaters should not be used in a room that has limited air exchange with adjacent spaces because combustion air is drawn from the space.

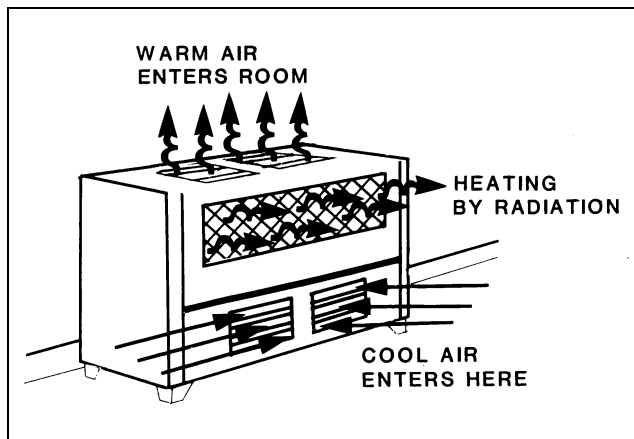

Fig. 1 Room Heater

The preparation of this chapter is assigned to TC 6.4, In-Space Convection Heating.

Unvented radiant or convection heaters range in size from 10,000 to 40,000 Btu/h and can be freestanding units or wall-mounted, nonrecessed units of either the radiant or closed-front type. Unvented room heaters require an outside air intake. The size of the fresh air opening required is marked on the heater. To ensure adequate fresh air supply, unvented gas-heating equipment must, according to voluntary standards, include a device that shuts the heater off if the oxygen in the room becomes inadequate. Unvented room heaters may not be installed in hotels, motels, or rooms of institutions such as hospitals or nursing homes.

Catalytic room heaters are fitted with fibrous material impregnated with a catalytic substance that accelerates the oxidation of a gaseous fuel to produce heat without flames. The design distributes the fuel throughout the fibrous material so that oxidation occurs on the surface area in the presence of a catalyst and room air. Catalytic heaters transfer heat by low-temperature radiation and by convection. The surface temperature is below a red heat and is generally below 1200°F at the maximum fuel input rate. The flameless combustion of catalytic heaters is an inherent safety feature not offered by conventional flame-type gas-fueled burners. Catalytic heaters have also been used in agriculture and for industrial applications in combustible atmospheres.

Unvented household catalytic heaters are used in Europe. Most of these are portable and mounted on casters in a casing that includes a cylinder of liquefied petroleum gas (LPG) so that they may be rolled from one room to another. LPG cylinders holding more than 2 lb of fuel are not permitted for indoor use in the United States. As a result, catalytic room heaters sold in the United States are generally permanently installed and fixed as wall-mounted units. Local codes and the *National Fuel Gas Code* (NFPA Standard 54/ANSI Z223.1) should be reviewed for accepted combustion air requirements.

Wall Furnaces

A wall furnace is a self-contained vented appliance with grilles that are designed to be a permanent part of the structure of a building (Figure 2). It furnishes heated air that is circulated by natural or forced convection. A wall furnace can have boots, which may not extend more than 10 in. beyond the horizontal limits of the casing through walls of normal thickness, to provide heat to adjacent rooms. Wall furnaces range from 10,000 to 90,000 Btu/h. Wall furnaces are classified as conventional or direct vent.

Conventional vent units require approved B-1 vent pipes and are installed to comply with the *National Fuel Gas Code*. Some wall furnaces are counterflow units that use fans to reverse the natural flow of air across the heat exchanger. Air enters at the top of the furnace and discharges at or near the floor. Counterflow systems reduce heat stratification in a room. As with any vented unit, a minimum of inlet air for proper combustion must be supplied.

Vented-recessed wall furnaces are recessed into the wall, with only the decorative grillwork extending into the room. This leaves more usable area in the room being heated. Dual-wall furnaces are

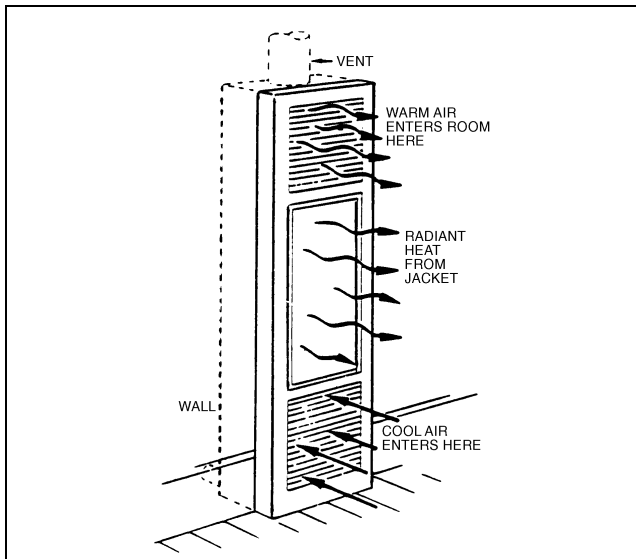

Fig. 2 Wall Furnace

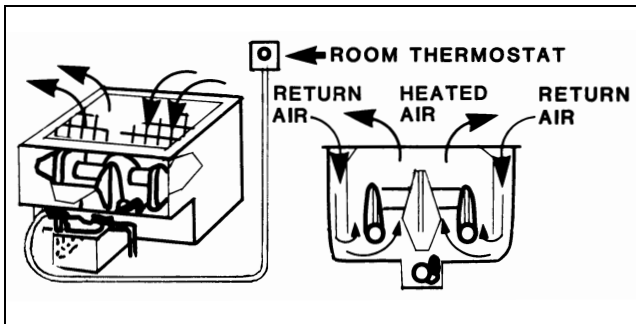

Fig. 3 Floor Furnace

two units that fit between the studs of adjacent rooms, thereby using a common vent.

Both vented-recessed and dual-wall furnaces are usually natural convection units. Cool room air enters at the bottom and is warmed as it passes over the heat exchanger, entering the room through the grillwork at the top of the heater. This process continues as long as the thermostat calls for the burners to be on. Accessory fans assist in the movement of air across the heat exchanger and help minimize air stratification.

Direct vent wall furnaces are constructed so that combustion air comes from outside, and all flue gases discharge into the outside atmosphere. These appliances include grilles or the equivalent and are designed to be attached to the structure permanently. Direct vent wall heaters are normally mounted on walls with outdoor exposure.

Direct vent wall furnaces can be used in extremely tight (well-insulated) rooms because combustion air is drawn from outside the room. There are no infiltration losses for dilution or combustion air. Most direct vent heaters are designed for natural convection, although some may be equipped with fans. Direct vent furnaces are available with inputs of 6000 to 65,000 Btu/h.

Floor Furnaces

Floor furnaces are self-contained units suspended from the floor of the heated space (Figure 3). Combustion air is taken from outside, and flue gases are also vented outside. Cold air returns at the periphery of the floor register, and warm air comes up to the room through the center of the register.

Table 1 Efficiency Requirements in the United States for Gas-Fired Direct Heating Equipment

Input, 1000 Btu/h	Minimum AFUE, %	Input, 1000 Btu/h	Minimum AFUE, %
<i>Wall Furnace (with fan)</i>		<i>Floor Furnace</i>	
< 42	73	< 37	56
> 42	74	> 37	57
<i>Wall Furnace (gravity type)</i>		<i>Room Heaters</i>	
< 10	59	< 18	57
10 to 12	60	18 to 20	58
12 to 15	61	20 to 27	63
15 to 19	62	27 to 46	64
19 to 27	63	> 46	65
27 to 46	64		
> 46	65		

United States Minimum Efficiency Requirements

The National Appliance Energy Conservation Act (NAECA) of 1987 mandates minimum annual fuel utilization efficiency (AFUE) requirements for gas-fired direct heating equipment (Table 1). The minimums (effective as of January 1, 1990) are measured using the U.S. Department of Energy test method (DOE 1984) and must be met by manufacturers of direct heating equipment (i.e., gas-fired room heaters, wall furnaces, and floor furnaces).

CONTROLS

Valves

Gas in-space heaters are controlled by four types of valves:

The full on-off, **single-stage valve** is controlled by a wall thermostat. Models are available that are powered by a 24 V supply or from energy supplied by the heat of the pilot light on the thermocouple (self-generating).

The **two-stage control valve** (with hydraulic thermostat) fires either at full input (100% of rating) or at some reduced step, which can be as low as 20% of the heating rate. The amount of time at the reduced firing rate depends on the heating load and the relative oversizing of the heater.

The **step-modulating control valve** (with a hydraulic thermostat) steps on to a low fire and then either cycles off and on at the low fire (if the heating load is light) or gradually increases its heat output to meet any higher heating load that cannot be met with the low firing rate. This control allows an infinite number of fuel firing rates between low and high fire.

The **manual control valve** is controlled by the user rather than by a thermostat. The user adjusts the fuel flow and thus the level of fire to suit heating requirements.

Thermostats

Temperature controls for gas in-space heaters are of the following two types.

- **Wall thermostats** are available in 24 and millivolt systems. The 24 V unit requires an external power source and a 24 V transformer. Wall thermostats respond to temperature changes and turn the automatic valve to either full-on or full-off. The millivolt unit requires no external power because the power is generated by multiple thermocouples and may be either 250 or 750 mV, depending on the distance to the thermostat. This thermostat also turns the automatic valve to either full-on or full-off.
- **Built-in hydraulic thermostats** are available in two types: (1) a snap-action unit with a liquid-filled capillary tube that responds to changes in temperature and turns the valve to either full-on or full-off; and (2) a modulating thermostat, which is similar to the

Table 2 Gas Input Required for In-Space Supplemental Heaters

Heater Type	Average AFUE, %	Steady State Efficiency, %	Gas Consumption per Unit House Volume, Btu/h per ft ³					
			Outside Air Temperature, °F					
			Older Bungalow ^a			Energy-Efficient House ^b		
Vented	54.6	73.1	6.5	3.8	1.6	2.8	1.6	0.7
Unvented	90.5	90.5	6.0	3.5	1.5	2.6	1.5	0.6
Direct vent	76.0	78.2	5.9	3.4	1.5	2.1	1.2	0.5

^aTested bungalow total heated volume = 6825 ft³ and $U \approx 0.3$ to 0.5 Btu/h·°F.

^bTested energy-efficient house total heated volume = 11,785 ft³ and $U \approx 0.2$ to 0.3 Btu/h·°F.

snap-action unit, except that the valve comes on and shuts off at a preset minimum input. Temperature alters the input anywhere from full-on to the minimum input. When the heating requirements are satisfied, the unit shuts off.

VENT CONNECTORS

Any vented gas-fired appliance must be installed correctly to vent combustion products. A detailed description of proper venting techniques is found in the *National Fuel Gas Code* and [Chapter 30](#).

SIZING UNITS

The size of the unit selected depends on the size of the room, the number and direction of exposures, the amount of insulation in the ceilings and walls, and the geographical location. Heat loss requirements can be calculated from procedures described in [Chapter 28 of the ASHRAE Handbook—Fundamentals](#).

DeWerth and Loria (1989) studied the use of gas-fired, in-space supplemental heaters in two test houses. They proposed a heater sizing guide, which is summarized in [Table 2](#). The energy consumption in [Table 2](#) is for unvented, vented, and direct vent heaters installed in (1) a bungalow built in the 1950s with average insulation, and (2) a townhouse built in 1984 with above-average insulation and tightness.

OIL AND KEROSENE IN-SPACE HEATERS

Vaporizing Oil Pot Heaters

These heaters have an oil-vaporizing bowl (or other receptacle) that admits liquid fuel and air in controllable quantities; the fuel is vaporized by the heat of combustion and mixed with the air in appropriate proportions. Combustion air may be induced by natural draft or forced into the vaporizing bowl by a fan. Indoor air is generally used for combustion and draft dilution. Window-installed units have the burner section outdoors. Both natural- and forced-convection heating units are available. A small blower is sold as an option on some models. The heat exchanger, usually cylindrical, is made of steel ([Figure 4](#)). These heaters are available as room units (both radiant and circulation), floor furnaces, and recessed wall heaters. They may also be installed in a window, depending on the cabinet construction. The heater is always vented to the outside. A 3 to 5 gal fuel tank may be attached to the heater, or a larger outside tank can be used.

Vaporizing pot burners are equipped with a single constant-level and metering valve. Fuel flows by gravity to the burner through the adjustable metering valve. Control can be manual, with an off pilot and variable settings up to maximum, or it can be thermostatically

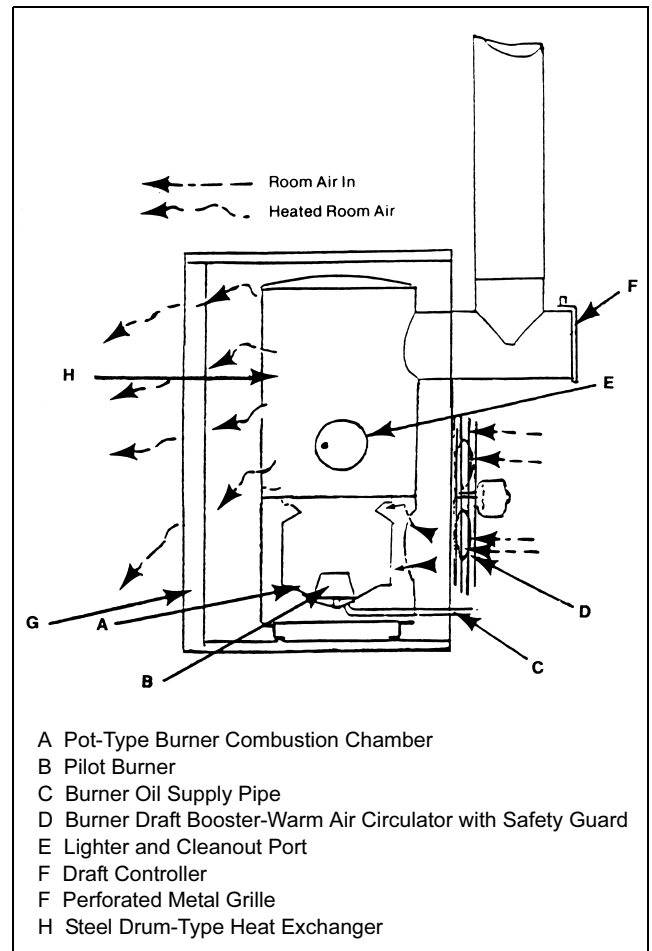

Fig. 4 Oil-Fueled Heater with Vaporizing Pot-Type Burner

controlled, with the burner operating at a selected firing rate between pilot and high.

Powered Atomizing Heaters

Wall furnaces, floor furnaces, and freestanding room heaters are also available with a powered gun-type burner using No. 1 or No. 2 fuel oil. For more information, refer to [Chapter 26](#).

Portable Kerosene Heaters

Because kerosene heaters are not normally vented, precautions must be taken to provide sufficient ventilation. Kerosene heaters are of four basic types: radiant, natural-convection, direct-fired, forced-convection, and catalytic.

The radiant kerosene heater has a reflector, while the natural convection heater is cylindrical in shape. Fuel vaporizes from the surface of a wick, which is immersed in an integral fuel tank of up to 2 gal capacity similar to that of a kerosene lamp. Fuel-burning rates range from about 5000 to 22,500 Btu/h. Radiant heaters usually have a removable fuel tank to facilitate refueling.

The direct-fired, forced-convection portable kerosene heater has a vaporizing burner and a heat-circulating fan. These heaters are available with thermostatic control and variable heat output.

The catalytic type uses a metal catalyst to oxidize the fuel. It is started by lighting kerosene at the surface; however, after a few moments, the catalyst surface heats to the point that flameless oxidation of the fuel begins.

ELECTRIC IN-SPACE HEATERS

Wall, Floor, Toe Space, and Ceiling Heaters

Heaters for recessed or surface wall mounting are made with open wire or enclosed, metal-sheathed elements. An inner liner or reflector is usually placed between the elements and the casing to promote circulation and minimize the rear casing temperature. Heat is distributed by both convection and radiation; the proportion of each depends on unit construction.

Ratings are usually 1000 to 5000 W at 120, 208, 240, or 277 V. Models with air circulation fans are available. Other types can be recessed into the floor. Electric convectors should be placed so that air moves freely across the elements.

Baseboard Heaters

These heaters consist of a metal cabinet containing one or more horizontal, enclosed, metal-sheathed elements. The cabinet is less than 6 in. in overall depth and can be installed 18 in. above the floor; the ratio of the overall length to the overall height is more than two to one.

Units are available from 2 to 12 ft in length, with ratings from 100 to 400 W/ft, and they fit together to make up any desired continuous length or rating. Electric hydronic baseboard heaters containing immersion heating elements and an antifreeze solution are made with ratings of 300 to 2000 W. The placement of any type of electric baseboard heater follows the same principles that apply to baseboard installations (see [Chapter 32](#)) because baseboard heating is primarily perimeter heating.

RADIANT HEATING SYSTEMS

Heating Panels and Heating Panel Sets

These systems have electric resistance wire or etched or graphite elements embedded between two layers of insulation. High-density thermal insulation behind the element minimizes heat loss, and the outer shell is formed steel with baked enamel finish. Heating panels provide supplementary heating by convection and radiation. They can be recessed into or surface mounted on hard surfaces or fit in standard T-bar suspended ceilings.

Units are usually rated between 250 and 1000 W in sizes varying from 24 in. by 24 in. to 24 in. by 96 in. in standard voltages of 120, 208, 240, and 277 V.

Embedded Cable and Storage Heating Systems

Ceiling and floor electric radiant heating systems that incorporate embedded cables are covered in [Chapter 6](#). Electric storage systems, including room storage heaters and floor slab systems, are covered in [Chapter 34 of the ASHRAE Handbook—Applications](#).

Cord-Connected Portable Heaters

Portable electric heaters are often used in areas that are not accessible to central heat. They are also used to maintain an occupied room at a comfortable level independent of the rest of the residence.

Portable electric heaters for connection to 120 V, 15 A outlets are available with outputs of 2050 to 5100 Btu/h (600 to 1500 W), the most common being 1320 and 1500 W. Many heaters are available with a selector switch for three wattages (e.g., 1100-1250-1500 W). Heavy-duty heaters are usually connected to 240 V, 20 A outlets with outputs up to 13,700 Btu/h (4000 W), while those for connection to 240 V, 30 A outlets have outputs up to 19,100 Btu/h (5600 W). All electric heaters of the same wattage produce the same amount of heat.

Portable electric heaters transfer heat by one of two predominant methods: radiation and convection. Radiant heaters provide heat for people or objects. An element in front of a reflector radiates heat

outward in a direct line. Conventional radiant heaters have ribbon or wire elements. Quartz radiant heaters have coil wire elements encased in quartz tubes. The temperature of a radiant wire element usually ranges between 1200 and 1600°F.

Convection heaters warm the air in rooms or zones. Air flows directly over the hot elements and mixes with room air. Convection heaters are available with or without fans. The temperature of a convection element is usually less than 930°F.

An adjustable, built-in bimetal thermostat usually controls the power to portable electric heaters. Fan-forced heaters usually provide better temperature control because the fan, in addition to cooling the case, forces room air past the thermostat. One built-in control uses a thermistor to signal a solid logic circuit that adjusts wattage and fan speed. Most quartz heaters use an adjustable control that operates the heater for a percentage of total cycle time from 0 (off) to 100% (full-on).

Controls

Low-voltage and line-voltage thermostats with on-off operation are used to control in-space electric heaters. Low-voltage thermostats, operating at 30 V or less, control relays or contactors that carry the rated voltage and current load of the heaters. Because the control current load is small (usually less than 1 A), the small switch can be controlled by a highly responsive sensing element.

Line-voltage thermostats carry the full load of the heaters at rated voltage directly through their switch contacts. Most switches carry a listing by Underwriters Laboratories (UL) at 22 A (resistive), 277 V rating. While most electric in-space heating systems are controlled by remote wall-mounted thermostats, many are available with integral or built-in line-voltage thermostats.

Most low-voltage and line-voltage thermostats use small internal heaters, either fixed or adjustable in heat output, that provide heat anticipation by energizing when the thermostat contacts close. The cycling rate of the thermostat is increased by the use of anticipation heaters, resulting in more accurate control of the space temperature.

Droop is an apparent shift or lowering of the control point and is associated with line-voltage thermostats. In these thermostats, switch heating caused by large currents can add materially to the amount of droop. Most line-voltage thermostats in residential use control room heaters of 3 kW (12.5 A at 240 V) or less. At this moderate load and with properly sized anticipation heaters, the droop experienced is acceptable. Cycling rates and droop characteristics have a significant effect on thermostat performance.

SOLID-FUEL IN-SPACE HEATERS

Most wood-burning and coal-burning devices, except central wood-burning furnaces and boilers, are classified as solid-fuel in-space heaters (see [Table 3](#)). An in-space heater can be either a fireplace or a stove.

FIREPLACES

Simple Fireplaces

Simple fireplaces, especially all-masonry and noncirculating metal built-in fireplaces, produce little useful heat. They lend atmosphere and a sense of coziness to a room. Freestanding fireplaces are slightly better heat producers. Simple fireplaces have an average efficiency of about 10%. In extreme cases, the chimney draws more heated air than the fire produces.

The addition of glass doors to the front of a fireplace has both a positive and a negative effect. The glass doors restrict the free flow of indoor heated air up the chimney, but at the same time they restrict the radiation of the heat from the fire into the room.

Table 3 Solid-Fuel In-Space Heaters

Type ^a	Approximate Efficiency ^a , %	Features	Advantages	Disadvantages
Simple fireplaces, masonry or prefabricated	-10 to +10	Open front. Radiates heat in one direction only.	Visual beauty.	Low efficiency. Heats only small areas.
High-efficiency fireplaces	25 to 45	Freestanding or built-in with glass doors, grates, ducts, and blowers.	Visual beauty. More efficient. Heats larger areas. Long service life. Maximum safety.	Medium efficiency.
Box stoves	20 to 40	Radiates heat in all directions.	Low initial cost. Heats large areas.	Fire hard to control. Short life. Wastes fuel.
Airtight stoves	40 to 55	Radiates heat in all directions. Sealed seams, effective draft control.	Good efficiency. Long burn times, high heat output. Longer service life.	Can create creosote problems.
High-efficiency catalytic wood heaters	65 to 75	Radiates heat in all directions. Sealed seams, effective draft control.	Highest efficiency. Long burn times, high heat output. Long life.	Creosote problems. High purchase price.

^aProduct categories are general; product efficiencies are approximate.

Factory-Built Fireplaces

A factory-built fireplace consists of a fire chamber, chimney, roof assembly, and other parts that are factory made and intended to be installed as a unit in the field. These fireplaces have fireboxes of refractory-lined metal rather than masonry. Factory-built fireplaces come in both radiant and heat-circulating designs. Typical configurations are open front designs, but corner-opening, three-sided units with openings either on the front or side; four-sided units; and see-through fireplaces are also available.

Radiant Design. The radiant system transmits heat energy from the firebox opening by direct radiation to the space in front of it. These fireplaces may also incorporate such features as an outside air supply and glass doors. Radiant design factory-built fireplaces are primarily used for aesthetic wood burning and typically have efficiencies similar to those of masonry fireplaces (0 to 10%).

Heat-Circulating Design. This unit transfers heat by circulating air around the fire chamber and releasing to the space to be heated. The air intake is generally below the firebox or low on the sides adjacent to the opening, and the heated air exits through grilles or louvers located above the firebox or high on the sides adjacent to it. In some designs, ducts direct heated air to spaces other than the area near the front of the fireplace. Some circulating units rely on natural convection, while others have electric fans or blowers to move air. These energy-saving features typically boosts efficiency 25 to 60%.

Freestanding Fireplaces

Freestanding fireplaces are open-combustion wood-burning appliances that are not built into a wall or chase. One type of freestanding fireplace is a fire pit in which the fire is open all around; smoke rises into a hood and then into a chimney. Another type is a prefabricated metal unit that has an opening on one side. Because they radiate heat to all sides, freestanding fireplaces are typically more efficient than radiant fireplaces.

STOVES

Conventional Wood Stoves

Wood stoves are chimney-connected, solid-fuel-burning room heaters designed to be operated with the fire chamber closed. They deliver heat directly to the space in which they are located. They are not designed to accept ducts and/or pipes for heat distribution to other spaces. Wood stoves are controlled-combustion appliances. Combustion air enters the firebox through a controllable air inlet; the air supply and thus the combustion rate are controlled by the user. Conventional controlled-combustion wood stoves manufactured prior to the mid-1980s typically have overall efficiencies ranging from 40 to 55%.

Most **controlled-combustion** appliances are constructed of steel, cast iron, or a combination of the two metals; others are constructed of soapstone or masonry. Soapstone and masonry have lower thermal conductivities but greater specific heats (the amount of heat that can be stored in a given mass). Other materials such as special refractories and ceramics are used in low-emission appliances. Wood stoves are classified as either radiant or convection (sometimes called circulating) heaters, depending on the way they heat interior spaces.

Radiant wood stoves are generally constructed with single exterior walls, which absorb radiant heat from the fire. This appliance heats primarily by infrared radiation; it heats room air only to the extent that air passes over the hot surface of the appliance.

Convection wood stoves have double vertical walls with an air space between the walls. The double walls are open at the top and bottom of the appliance to permit room air to circulate through the air space. The more buoyant hot air rises and draws in cooler room air at the bottom of the appliance. This air is then heated as it passes over the surface of the inner radiant wall. Some radiant heat from the inner wall is absorbed by the outer wall, but the constant introduction of room temperature air at the bottom of the appliance keeps the outer wall moderately cool. This characteristic generally allows convection wood stoves to be placed closer to combustible materials than radiant wood stoves. Fans in some wood stoves augment the movement of heated air. Convection wood stoves generally provide more even heat distribution than do radiant types.

Advanced Design Wood Stoves

Strict air pollution standards have prompted the development of new stove designs. These clean-burning wood stoves use either catalytic or noncatalytic technology to achieve very high combustion efficiency and to reduce creosote and particulate and carbon monoxide emission levels.

Catalytic combustors are currently available as an integral part of many new wood-burning appliances and are also available as add-on or retrofit units for most existing appliances. The catalyst may be platinum, palladium, rhodium, or a combination of these elements. It is bonded to a ceramic or stainless steel substrate. A catalytic combustor's function in a wood-burning appliance is to substantially lower the ignition temperatures of unburned gases, solids, and/or liquid droplets (from approximately 1000°F to 500°F). As these unburned combustibles leave the main combustion chamber and pass through the catalytic combustor, they ignite and burn rather than enter the atmosphere.

For the combustor to efficiently burn the gases, the proper amount of oxygen and a sufficient temperature to maintain ignition are required; further, the gases must have sufficient residence time in the combustor. A properly operating catalytic combustor has a

temperature in the range of 1000 to 1700°F. Catalyst-equipped wood stoves have a default efficiency, as determined by the U.S. Environmental Protection Agency (EPA), of 72%, although many stoves are considerably more efficient. This EPA default efficiency is the value one standard deviation below the mean of the efficiencies from a database of stoves.

Another approach to increasing combustion efficiency and meeting emissions requirements is the use of technologically advanced internal appliance designs and materials. Generally, noncatalytic, low-emission wood-burning appliances incorporate high-temperature refractory materials and have smaller fireboxes than conventional appliances. The fire chamber is designed to increase temperature, turbulence, and residence time in the primary combustion zone. Secondary air is introduced to promote continued burning of the gases, solids, and liquid vapors in a secondary combustion zone. Many stoves add a third and fourth burn area within the firebox. The location and design of the air inlets is critical because proper air circulation patterns are the key to approaching complete combustion. Noncatalytic wood stoves have an EPA default efficiency of 63%; however, many models approach 80%.

Fireplace Inserts

Fireplace inserts are closed-combustion wood-burning room heaters that are designed to be installed in an existing masonry fireplace. They combine elements of both radiant and convection wood stove designs. They have large radiant surfaces that face the room and circulating jackets on the sides that capture heat that would otherwise go up the chimney. Inserts may use either catalytic or non-catalytic technology to achieve clean burning.

Pellet-Burning Stoves

Pellet-burning stoves burn small pellets made from wood by-products rather than burning logs. An electric auger feeds the pellets from a hopper into the fire chamber, where air is blown through, creating very high temperatures in the firebox. The fire burns at such a high temperature that the smoke is literally burned up, resulting in a very clean burn, and no chimney is needed. Instead, the waste gases are exhausted to the outside through a vent. An air intake is operated by an electric motor; another small electric fan blows the heated air from the area around the fire chamber into the room. A microprocessor controls the operation, allowing the pellet-burning stove to be controlled by a thermostat. Pellet-burning stoves typically have the lowest emissions of all wood-burning appliances and have an EPA default efficiency of 78%. Because of the high air-fuel ratios used by pellet-burning stoves, these stoves are excluded from EPA wood stove emissions regulations.

GENERAL INSTALLATION PRACTICES

The criteria to ensure safe operation are normally covered by local codes and ordinances or, in rare instances, by state and federal requirements. Most codes, ordinances, or regulations refer to the following building codes and standards for in-space heating:

Building Codes

BOCA/National Building Code	BOCA
CABO One- and Two-Family Dwelling Code	CABO
International Building Code	ICC
National Building Code of Canada	NBCC
Standard Building Code	SBCCI
Uniform Building Code	ICBO

Mechanical Codes

National Mechanical Code	BOCA
Uniform Mechanical Code	ICBO/IAPMO

International Mechanical Code	ICC
Standard Mechanical Code	SBCCI
Electrical Codes	
National Electrical Code	NFPA 70
Canadian Electrical Code	CSA C22.1
Chimneys	
Chimneys, Fireplaces, Vents and Solid Fuel-Burning Appliances	NFPA 211
Chimneys, Factory-Built Residential Type and Building Heating Appliance	UL 103
Solid-Fuel Appliances	
Factory-Built Fireplaces	UL 127
Room Heaters, Solid-Fuel Type	UL 1482

The chapter on Codes and Standards has further information, including the names and addresses of these agencies. Safety and performance criteria are furnished by the manufacturer.

Safety with Solid Fuels

The evacuation of combustion gases is a prime concern in the installation of solid-fuel-burning equipment. NFPA *Standard* 211, Chimneys, Fireplaces, Vents and Solid Fuel-Burning Appliances, lists requirements that should be followed. Because safety requirements for connector pipes (stovepipes) are not always readily available, these requirements are summarized as follows:

- Connector pipe is usually black (or blue) steel single-wall pipe; thicknesses are shown in [Table 4](#). Stainless steel is a corrosion-resistant alternative that does not have to meet the thicknesses listed in [Table 4](#).
- Connectors should be installed with the crimped (male) end of the pipe toward the stove, so that creosote and water drip back into the stove.
- The pipe should be as short as is practical, with a minimum of turns and horizontal runs. Horizontal runs should be pitched 1/4 in. per foot up toward the chimney.
- Chimney connectors should not pass through ceilings, closets, alcoves, or concealed spaces.
- When passing through a combustible interior or exterior wall, connectors must be routed through a listed wall pass-through that has been installed in accordance with the conditions of the listing, or they must follow one of the home-constructed systems recognized in NFPA *Standard* 211 or local building codes. Adequate clearance and protection of combustible materials is extremely important. In general, listed devices are easier to install and less expensive than home-constructed systems.

Creosote forms in all wood-burning systems. The rate of formation is a function of the quantity and type of fuel burned, the appliance in which it is burned, and the manner in which the appliance is operated. Thin deposits in the connector pipe and chimney do not interfere with operation, but thick deposits (greater than 1/4 in.) may ignite. Inspection and cleaning of chimneys connected to wood-burning appliances should be performed on a regular basis (at least annually).

Only the solid fuel that is listed for the appliance should be burned. Coal should be burned only in fireplaces or stoves designed specifically for coal burning. The chimney used in coal-fired applications must also be designed and approved for coal and wood.

Solid-fuel appliances should be installed in strict conformance with the clearance requirements established as part of their safety listing. When clearance reduction systems are used, stoves must remain at least 12 in. and connector pipe at least 6 in. from combustibles, unless smaller clearances are established as part of the listing.

Table 4 Chimney Connector Wall Thickness^a

Diameter	Gage	Minimum Thickness, in.
Less than 6 in.	26	0.019
6 to 10 in.	24	0.023
10 to 16 in.	22	0.029
16 in. or greater	16	0.056

^aDo not use thinner connector pipe. Replace connectors as necessary. Leave at least 18 in. clearance between the connector and a wall or ceiling, unless the connector is listed for a smaller clearance or an approved clearance reduction system is used.

Utility-Furnished Energy

Those systems that rely on energy furnished by a utility are usually required to comply with local utility service rules and regulations. The utility usually provides information on the installation and operation of the equipment using their energy. Bottled gas (LPG) equipment is generally listed and tested under the same standards as natural gas. LPG equipment may be identical to natural gas equipment, but it always has a different orifice and sometimes has a different burner and controls. The listings and examinations are usually the same for natural, mixed, manufactured, and liquid petroleum gas.

Products of Combustion

The combustion chamber of equipment that generates products of combustion must be connected by closed piping to the outdoors. Gas-fired equipment may be vented through masonry stacks, chimneys, specifically designed venting, or, in some cases, venting incorporating forced- or induced-draft fans. [Chapter 30](#) covers chimneys, gas vents, and fireplace systems in more detail.

Agency Testing

The standards of several agencies contain guidelines for the construction and performance of in-space heaters. The following list summarizes the standards that apply to residential in-space heating; they are coordinated or sponsored by ASHRAE, the American National Standards Institute (ANSI), Underwriters Laboratories (UL), the American Gas Association (AGA), and the Canadian Gas Association (CGA). Some CGA standards have a CAN1 prefix.

ANSI Z21.11.1	Gas-Fired Room Heaters, Vented
ANSI Z21.11.2	Gas-Fired Room Heaters, Unvented
ANSI Z21.44	Gas-Fired Gravity and Fan-Type Direct-Vent Wall Furnaces
ANSI Z21.48	Gas-Fired Gravity and Fan-Type Floor Furnaces
ANSI Z21.49	Gas-Fired Gravity and Fan-Type Vented Wall Furnaces

ANSI Z21.60/ CSA 2.26-M96	Decorative Gas Appliances for Installation in Solid-Fuel Burning Fireplaces
ANSI Z21.76	Gas-Fired Unvented Catalytic Room Heaters for use with Liquefied Petroleum (LP) Gases
ANSI Z21.50/ CSA 2.22-M98	Vented Gas Fireplaces
ANSI Z21.86/ CSA 2.32-M98	Vented Gas-Fired Space Heating Appliances
ANSI Z21.88/ CSA 2.33-M98	Vented Gas Fireplace Heaters
CAN1-2.1-M86	Gas-Fired Vented Room Heaters
CAN/CGA-2.5-M86	Gas-Fired Gravity and Fan Type Vented Wall Furnaces
CAN1/CGA-2.19-M81	Gas-Fired Gravity and Fan Type Direct Vent Wall Furnaces
ANSI/UL 127	Factory-Built Fireplaces
UL 574	Electric Oil Heaters
UL 647	Unvented Kerosene-Fired Heaters and Portable Heaters
ANSI/UL 729	Oil-Fired Floor Furnaces
ANSI/UL 730	Oil-Fired Wall Furnaces
UL 737	Fireplace Stoves
ANSI/UL 896	Oil-Burning Stoves
ANSI/UL 1042	Electric Baseboard Heating Equipment
ANSI/UL 1482	Heaters, Room Solid-Fuel Type
ASHRAE 62	Ventilation for Acceptable Indoor Air Quality

REFERENCES

- DeWerth, D.W. and R.L. Loria. 1989. In-space heater energy use for supplemental and whole house heating. *ASHRAE Transactions* 95(1).
- DOE. 1984. Uniform test method for measuring the energy consumption of vented home heating equipment. *Federal Register* 49:12, 169 (March).
- GAMA. 1995. Directory of gas room heaters, floor furnaces and wall furnaces. Gas Appliance Manufacturers Association, Arlington, VA.
- MacKay, S., L.D. Baker, J.W. Bartok, and J.P. Lassoie. 1985. *Burning wood and coal*. Natural Resources, Agriculture, and Engineering Service, Cornell University, Ithaca, NY.
- NFPA. 1996. Standard for chimneys, fireplaces, vents and solid fuel-burning appliances. *Standard 211-1996*. National Fire Protection Association, Quincy, MA.
- NFPA/AGA. 1999. *National fuel gas code*. NFPA Standard 54-99. National Fire Protection Association, Quincy, MA. ANSI Standard Z223.1-99. American Gas Association, Arlington, VA.
- Wood Heating Education and Research Foundation. 1984. Solid fuel safety study manual for Level I solid fuel safety technicians. Washington, D.C.