

## CHAPTER 17

## ENGINE TEST FACILITIES

<i>Engine Heat Release</i> .....	17.1	<i>Chassis Dynamometer Rooms</i> .....	17.3
<i>Engine Exhaust</i> .....	17.1	<i>Ventilation</i> .....	17.4
<i>Internal Combustion Engine Test Cells</i> .....	17.2	<i>Combustion Air Supply</i> .....	17.4
<i>Test Cell Supply</i> .....	17.3	<i>Cooling Water Systems</i> .....	17.4
<i>Gas-Turbine Test Cells</i> .....	17.3	<i>Noise</i> .....	17.4

**I**NDUSTRIAL testing of turbine and internal combustion engines is performed in enclosed test spaces to control noise and isolate the test for safety or security. These spaces are ventilated or conditioned to control the facility environment and fumes. Isolated engines are tested in test cells; engines inside automobiles are tested on chassis dynamometers. The ventilation and safety principles for test cells also apply when large open areas in the plant are used for production testing and emissions measurements.

Enclosed test cells are normally found in research or emissions test facilities. Test cells may require instruments to measure cooling system water flow and temperature; exhaust gas flow, temperature, and emission concentrations; fuel flow; power output; and combustion air volume and temperature. Changes in the temperature and humidity of the test cell affect these measurements. Accurate control of the testing environment is becoming more critical. For example, the U.S. Environmental Protection Agency requires tests to demonstrate control of automobile contaminants in both hot and cold environments.

Air conditioning and ventilation of test cells must (1) supply and exhaust proper quantities of air to remove heat and control temperature; (2) exhaust sufficient air at proper locations to prevent buildup of combustible vapors; (3) supply and modulate large quantities of air to meet changing conditions; (4) remove exhaust fumes; (5) supply combustion air; (6) prevent noise transmission through the system; (7) provide for human comfort and safety during setup, testing, and tear-down; and (8) treat the exhaust effluent. Supply and exhaust systems for test cells may be unitary, central, or a combination of the two. Mechanical exhaust is necessary in all cases.

**Special Warning:** Certain industrial spaces may contain flammable, combustible, and/or toxic concentrations of vapors or dusts under either normal or abnormal conditions. In spaces such as these, there are life-safety issues that this chapter may not completely address. Special precautions must be taken in accordance with requirements of recognized authorities such as the National Fire Protection Association (NFPA), the Occupational Safety and Health Administration (OSHA), and the American National Standards Institute (ANSI). In all situations, engineers, designers, and installers who encounter conflicting codes and standards must defer to the code or standard that best addresses and safeguards life safety.

## 1. ENGINE HEAT RELEASE

The special air-conditioning requirements of an engine test facility stem from burning the fuel used to run the engine. For internal combustion engines at full load, 10% of the total heat content of the fuel is radiated and convected into the room or test cell atmosphere, and 90% is fairly evenly divided between the shaft output (work), exhaust gas heating, and heating of the jacket cooling water.

Air-cooled engines create a forced convection load on the test space equal to the jacket water heat that it replaces. For turbine

engines, the exhaust gas carries double the heat of the internal combustion engine exhaust and there is no jacket water to heat. The engine manufacturer can provide a more precise analysis of heat release characteristics at various speeds and power outputs.

Test facilities use dynamometers to determine the power supplied by the engine shaft. The dynamometer converts shaft work into heat that must be accounted for by a cooling system or as heat load into the space. Often, shaft work is converted into electricity through a generator and the electric power is dissipated by a resistance load bank or sold to the local utility. Inefficiencies of the various pieces of equipment add to the load of the space in which they are located.

Heat released into the jacket water must also be removed. If a closely connected radiator is used, the heat load is added to the room load. Many test facilities include a heat exchanger and a secondary cooling circuit transfers the heat to a cooling tower. Some engines require an oil cooler separate from the jacket water. Whichever system is used, the cooling water flow, temperature, and pressure are usually monitored as part of the test operation and heat from these sources needs to be accommodated by the facility's air conditioning.

Exhaust systems present several challenges to engine test cell design. Exhaust gases can exit the engine at 800°C or higher. Commonly, the exhaust gas is augmented by inserting the exhaust pipe into a larger-bore exhaust system (laboratory fixed system), which draws room air into the exhaust to both cool the gas and ventilate the test cell. Both the exhausted room air and combustion air must be supplied to the room from the HVAC or from the outdoor.

Radiation and convection from exhaust pipes, catalytic converter, muffler, etc., also add to the load. In most cases, the test cell's HVAC system should account for an engine that can fully load the dynamometer, and have capacity control for operation at partial and no load.

Large gas turbine engines have unique noise and airflow requirements; therefore, they usually are provided with dedicated test cells. Small gas turbines can often be tested in a regular engine test cell with minor modifications.

## 2. ENGINE EXHAUST

Engine exhaust systems remove combustible products, unburned fuel vapors, and water vapor. Flow loads and operating pressure need to be established for design of the supporting HVAC.

**Flow loads** are calculated based on the number of engines, the engine sizes and loads, and use factors or diversity.

**Operating pressure** is the engine discharge pressure at the connection to the exhaust. Systems may operate at positive pressure using available engine tail-pipe pressure to force the flow of gas, or at negative pressure with mechanically induced flow.

The simplest way to induce engine exhaust from a test cell is to size the exhaust pipe to minimize variations in pressure on the engine and to connect it directly to the outdoor (Figure 1A). Exhausts directly connected to the outdoor are subject to wind currents and air pressure, however, and can be hazardous because of positive pressure in the system.

The preparation of this chapter is assigned to TC 9.2, Industrial Air Conditioning.

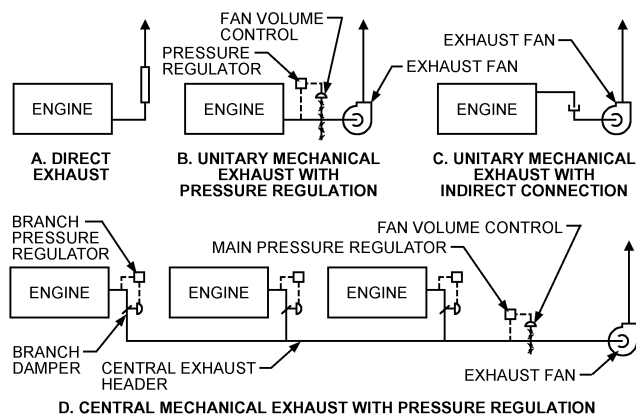

Fig. 1 Engine Exhaust Systems

Mechanical engine exhausts are either unitary or central. A **unitary exhaust** (Figure 1B) serves only one test cell, and can be closely regulated to match the engine's operation. A **central exhaust** (Figure 1D) serves multiple test cells with one or more exhaust fans and a duct system with branch connections to the individual test cells. Relief of a possible explosion in the ductwork should be considered.

Engine exhaust pressures fluctuate with changes in engine load and speed. Central exhausts should be designed to minimize effects of load variations in individual test cells on the system. Engine characteristics and diversity of operation determine the maximum airflow to be handled. Dampers and pressure regulators may be required to keep pressures within test tolerances.

An indirect connection between the engine exhaust pipe and mechanical exhaust gas removal (Figure 1C) eliminates variation in back pressure and augments exhaust gas flow by inducing room air into the exhaust stream. In this system the engine exhaust pipe terminates by being centered and inserted about 75 mm into the augmentation pipe, which is at least 25 mm larger in diameter. The induced room air is mixed with the exhaust gases, yielding a much cooler exhaust flow. However, the potential for increased corrosion in a cooler exhaust must be considered when selecting construction materials. The engine muffler should be located upstream of the augmentation connection to control noise. The indirect connection should be considered a potential point of ignition if the exhaust is fuel rich and the tail pipe reaches temperatures above 370°C.

Exhaust pipes and mufflers run very hot. A ventilated heat shield or a water-jacketed pipe reduces cell heat load, and some exhausts are equipped with direct water injection. Thermal expansion, stress, and pressure fluctuations must also be considered in the design of the exhaust fan and ducting. The equipment must be adequately supported and anchored to relieve the thermal expansion.

Exhaust systems for chassis dynamometer installations must capture high-velocity exhaust from the tail pipe to prevent fume buildup in the room. An exhaust flow rate of 330 L/s has been used effectively for automobiles at a simulated speed of 100 km/h.

Engine exhaust should discharge through a stack extending above the roof to an elevation sufficient to allow the fumes to clear the building. Chapter 45 has further details about exhaust stacks. Codes or air emission standards may require that exhaust gases be cleaned before being discharged to atmosphere.

### 3. INTERNAL COMBUSTION ENGINE TEST CELLS

#### Test Cell Exhaust

Ventilation for test cells is based on exhaust requirements for (1) removal of heat generated by the engine, (2) emergency purging (removal of fumes after a fuel spill), and (3) continuous cell

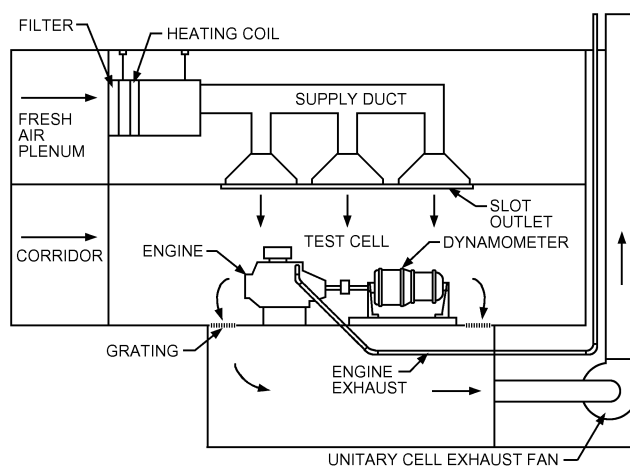

Fig. 2 Engine Test Cell Showing Direct Engine Exhaust: Unitary Ventilation System

scavenging during nonoperating periods. Heat is transferred to the test cell by convection and radiation from all of the heated surfaces, such as the engine and exhaust system. At a standard air density of  $\rho = 1.2 \text{ kg/m}^3$  and specific heat  $c_p = 1.0 \text{ kJ/(kg} \cdot \text{K)}$ ,

$$Q = \frac{q}{\rho c_p (t_e - t_s)} = \frac{q}{1.2(t_e - t_s)}$$

where

$$\begin{aligned} Q &= \text{airflow, m}^3/\text{s} \\ q &= \text{engine heat release, kW} \\ t_e &= \text{temperature of exhaust air, } ^\circ\text{C} \\ t_s &= \text{temperature of supply air, } ^\circ\text{C} \end{aligned}$$

The constant (1.2) should be corrected for other temperatures and pressures.

Heat radiated from the engine, dynamometer, and exhaust piping warms surrounding surfaces, which release heat to the air by convection. The value for  $(t_e - t_s)$  in the equation cannot be arbitrarily set when a portion of  $q$  is radiated heat. The section on Engine Heat Release discusses other factors required to determine the overall  $q$ .

**Vapor Removal.** The exhaust should remove vapors as quickly as possible. Emergency purging, often 50 L/s per square metre of floor area, should be controlled by a manual overriding switch for each test cell. In case of fire, provisions need to be made to shut down all equipment, close fire dampers at all openings, and shut off the fuel-flow solenoid valves.

**Cell Scavenging.** Exhaust air is the minimum amount of air required to keep combustible vapors from fuel leaks from accumulating. In general, the NFPA *Standard 30* requirement of 5 L/s per square metre of floor area is sufficient. Because gasoline vapors are heavier than air, exhaust grilles should be low even when an overhead duct is used. Exhausting close to the engine minimizes the convective heat that escapes into the cell.

In some installations, all air is exhausted through a floor grating surrounding the engine bed plate and into a cubicle or duct below. In this arrangement, slots in the ceiling over the engine supply a curtain of air to remove the heat. This scheme is particularly suitable for a central exhaust (Figure 2). Water sprays in the underfloor exhaust lessen the danger of fire or explosion in case of fuel spills.

Trenches and pits should be avoided in test cells. If they exist, as in most chassis dynamometer rooms, they should be mechanically exhausted at all times. Long trenches may require multiple exhaust takeoffs. The exhaust should sweep the entire area, leaving no dead

**Table 1 Exhaust Quantities for Test Cells**

	Minimum Exhaust Rates per Square Metre of Floor Area	
	L/s	ach <sup>a</sup>
Engine testing: cell operating	50	60 <sup>b</sup>
Cell idle	5	6
Trenches <sup>c</sup> and pits	50	—
Accessory testing	20	24
Control rooms and corridors	5	6

<sup>a</sup> Air changes per hour, based on cell height of 3 m.

<sup>b</sup> For chassis dynamometer rooms, this quantity is usually set by test requirements.

<sup>c</sup> For large trenches, use 0.5 m/s across the cross-sectional area of the trench.

air spaces. Because of fuel spills and vapor accumulation, suspended ceilings or basements should not be located directly below the engine test cell. If such spaces exist, they should be ventilated continuously and have no fuel lines running through them.

Table 1 lists exhaust quantities used in current practice; the exhaust should be calculated for each test cell on the basis of heat to be removed, evaporation of possible fuel spills, and the minimum ventilation needed during downtime.

#### 4. TEST CELL SUPPLY

The air supply to a test cell should be balanced to yield a slightly negative pressure. This is accomplished by having either an exhaust airflow 10% greater than the supply air or a differential pressure of the test cell at least 12.5 Pa less than the surrounding space. Test cell air should not be recirculated. Air taken from nontest areas can be used if good ventilation practices are followed, such as using air that is free of unacceptable contaminants, is sufficient for temperature control, and can maintain the proper test cell pressure.

Ventilation air should keep heat released from the engine away from cell occupants. Slot outlets with automatic dampers to maintain a constant discharge velocity have been used with variable-volume systems.

A variation of systems C and D in Figure 3 includes a separate air supply sized for the minimum (downtime) ventilation rate and for a cooling coil with room thermostat to regulate the coil to control the temperature in the cell. This system is useful in installations where much time is devoted to the setup and preparation of tests, or where constant temperature is required for complicated or sensitive instrumentation. Except for production and endurance testing, the actual engine operating time in test cells may be surprisingly low. The average test cell is used approximately 15 to 20% of the time.

Air should be filtered to remove particulates and insects. The degree of filtration is determined by the type of tests. Facilities in relatively unpolluted areas sometimes use unfiltered outdoor air.

Heating coils are needed to temper supply air if there is danger of freezing equipment or if low temperatures adversely affect tests. For low-temperature applications, a desiccant wheel with pre- and post-cooling may be needed with appropriate environmentally friendly refrigerants.

#### 5. GAS-TURBINE TEST CELLS

Large gas-turbine test cells must handle large quantities of air required by the turbine, attenuate the noise generated, and operate safely with a large flow of fuel. These cells are unitary and use the turbine to draw in untreated air and exhaust it through noise attenuators.

Small gas turbine engines can generally be tested in a conventional test cell with relatively minor modifications. The test-cell ventilation air supply and exhausts are sized for turbine-generated heat as

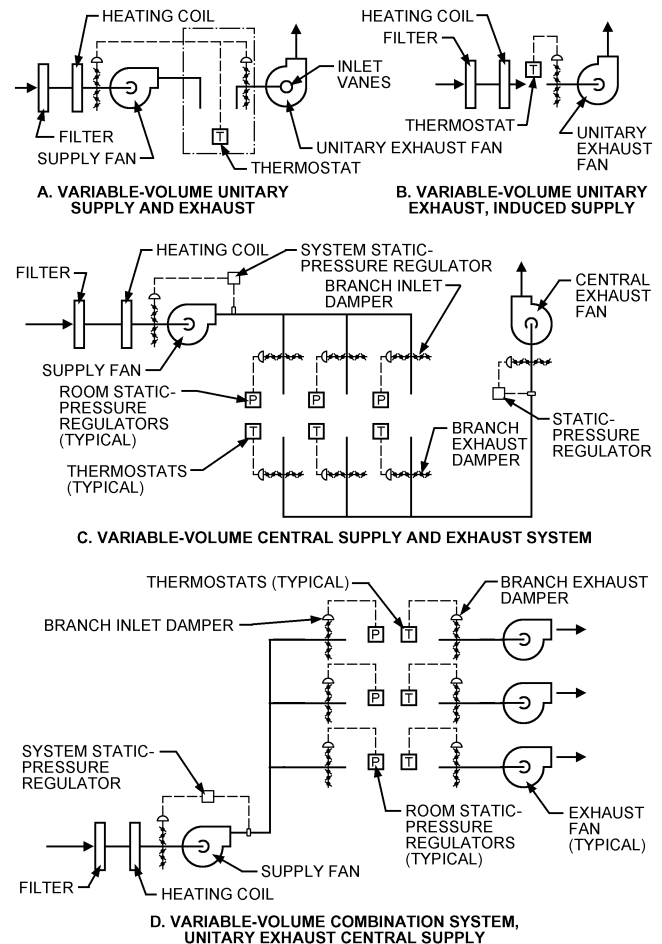
**Fig. 3 Heat Removal Ventilation Systems**

for a conventional engine. The combustion air supply for the turbine is considerable; it may be drawn from the cell, from outdoors, or through separate conditioning units that handle only combustion air.

Exhaust quantities are higher than from internal combustion engines and are usually ducted directly to the outdoors through muffling devices that provide little restriction to airflow. Exhaust air may be water-cooled, as temperature may exceed 700°C.

#### 6. CHASSIS DYNAMOMETER ROOMS

A chassis dynamometer (Figure 4) simulates road driving and acceleration conditions. The vehicle's drive wheels rest on a large roll, which drives the dynamometer. Air quantities, which are calibrated to correspond to air velocity at a particular road speed, flow across the front of the vehicle for radiator cooling and to approximate the effects of air speed on the body of the vehicle. Additional refinements may vary air temperature within prescribed limits from -40 to 55°C, control relative humidity, and/or add shakers to simulate road conditions. Air is usually introduced through an area approximating the frontal area of the vehicle. A duct with a return grille at the rear of the vehicle may be lowered so that air remains near the floor rather than cycling through a ceiling return air grille. Air is recirculated to air-handling equipment above the ceiling.

Chassis dynamometers are also installed in

- Cold rooms, where temperatures may be as low as -70°C
- Altitude chambers, where elevations up to 3700 m can be simulated
- Noise chambers for sound evaluation

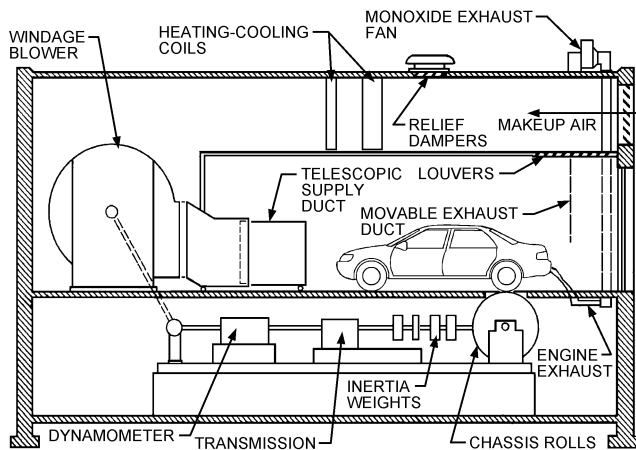

Fig. 4 Chassis Dynamometer Room

- Electromagnetic cells for evaluation of electrical components
- Environmental chambers
- Full-sized wind tunnels with throat areas much larger than the cross-sectional area of the vehicle. Combustion air is drawn directly from the room, but the engine exhaust must be installed in a way that will preserve the low temperature and humidity.

A temperature soak space is often placed near chassis dynamometer rooms having a controlled temperature. This space is used to cool or heat automobiles scheduled to enter the room. Generally, 18 to 24 h is required before the temperature of the vehicle stabilizes to the temperature of the room. The soak space and the temperature-controlled room are often isolated from the rest of the facility, with entry and egress through an air lock.

## 7. VENTILATION

Constant-volume systems with variable supply temperatures can be used; however, variable-volume, variable-temperature systems are usually selected. Ventilation is generally controlled on the exhaust side (see Figure 3). Unitary variable-volume systems (Figure 3A) use an individual exhaust fan and makeup air supply for each cell. Supply and exhaust fans are interlocked, and their operation is coordinated with the engine, usually by sensing the temperature of the cell. Some systems have exhaust only, with supply induced directly from outdoor (Figure 3B). The volume is varied by changing fan speed or damper position.

Ventilation with central supply fans, central exhaust fans, or both (Figure 3C) regulate air quantities by test cell temperature control of individual dampers or by two-position switches actuated by dynamometer operations. Air balance is maintained by static pressure regulation in the cell. Constant pressure in the supply duct is obtained by controlling supply fan inlet vanes, modulating dampers, or varying fan speed.

In systems with individual exhaust fans and central supply air, exhaust is controlled by cell temperature or a two-position switch actuated by dynamometer operation. The central supply system is controlled by a static pressure device in the cell to maintain room pressure (Figure 3D). Variable-volume exhaust airflow should not drop below minimum requirements. Exhaust requirements should override cell temperature requirements; thus, reheat may be needed.

Ventilation should be interlocked with fire protection to shut down the supply to and exhaust from the cell in case of fire. Exhaust fans should be nonsparking, and makeup air should be tempered.

Table 2 Typical Noise Levels in Test Cells

Type and Size of Engine	Sound Level 0.9 m from Engine, dBA			
	63 Hz	124 Hz	500 Hz	2000 Hz
Diesel				
Full load	105	107	98	99
Part load	70	84	56	49
Gasoline engine, 7.2 L at 5000 rpm				
Full load	107	108	104	104
Part load	75	—	—	—
Rotary engine, 75 kW				
Full load	90	90	83.5	86
Part load	79	78	75	72

## 8. COMBUSTION AIR SUPPLY

Combustion air is usually drawn from the test cell or introduced directly from the outdoors. Separate dedicated units can be used if combustion air must be closely regulated and conditioning of the entire test cell is impractical. These units filter, heat, and cool the supply air and regulate its humidity and pressure; they usually provide air directly to the engine air intake. Combustion air systems may be central units or portable packaged units.

## 9. COOLING WATER SYSTEMS

Dynamometers absorb and measure the useful output of an engine or its components. In a water-cooled dynamometer, engine work is converted to heat, which is absorbed by circulating water. Electrical dynamometers convert engine work to electrical energy, which can be used or dissipated as heat in resistance grids or load banks or sold to the local utility. Grids should be located outdoors or adequately ventilated.

Heat loss from electric dynamometers is approximately 8% of the measured output, plus a constant load of about 5 kW for auxiliaries in the cell. Recirculating water absorbs heat from the engine jacket water, oil coolers, and water cooled dynamometers through circulating pumps, cooling towers, or atmospheric coolers and hot- and cold-well collecting tanks.

## 10. NOISE

Noise generated by internal combustion engines and gas turbines must be considered in the design of a test cell air-handling system. Part of the engine noise is discharged through the tail pipe. If possible, internal mufflers should be installed to attenuate this noise at its source. Any ventilation ducts or pipe trenches that penetrate the cells must be insulated against sound transmission to other areas or to the outdoors. Attenuation equivalent to that provided by the cell structure should be applied to duct penetrations. Table 2 lists typical noise levels in test cells during engine operations.

## BIBLIOGRAPHY

- Bannasch, L.T., and G.W. Walker. 1993. Design factors for air-conditioning systems serving climatic automobile emission test facilities. *ASHRAE Transactions* 99(2):614-623.
- Computer controls engine test cells. *Control Engineering* 16(75):69.
- NFPA. 2008. Flammable and combustible liquids code. *Standard 30-2008*. National Fire Protection Association, Quincy, MA.
- Paulsell, C.D. 1990. *Description and specification for a cold weather emissions testing facility*. U.S. Environmental Protection Agency, Washington, D.C.
- Schuett, J.A., and T.J. Peckham. 1986. Advancements in test cell design. *SAE Transactions*, Paper 861215. Society of Automotive Engineers, Warrendale, PA.