

**CHAPTER 25**

**DRYING AND STORING SELECTED FARM CROPS**

<i>DRYING</i> .....	25.2	<i>Cotton</i> .....	25.8
<i>Drying Equipment and Practices</i> .....	25.2	<i>Peanuts</i> .....	25.8
<i>Shallow-Layer Drying</i> .....	25.3	<i>Rice</i> .....	25.9
<i>Deep -Bed Drying</i> .....	25.4	<i>STORAGE PROBLEMS AND PRACTICES</i> .....	25.9
<i>DRYING SPECIFIC CROPS</i> .....	25.7	<i>Moisture Migration</i> .....	25.9
<i>Soybeans</i> .....	25.7	<i>Grain Aeration</i> .....	25.9
<i>Hay</i> .....	25.7	<i>SEED STORAGE</i> .....	25.11

**C**ONTROL of moisture content and temperature during storage is critical to preserving the nutritional and economic value of farm crops as they move from the field to the market. Fungi (mold) and insects feed on poorly stored crops and reduce crop quality. Relative humidity and temperature affect mold and insect growth, which is reduced to a minimum if the crop is kept cooler than 10°C and if the relative humidity of the air in equilibrium with the stored crop is less than 60%.

Mold growth and spoilage are a function of elapsed storage time, temperature, and moisture content above critical values. Approximate allowable storage life for cereal grains is shown in [Table 1](#). For example, corn at 16°C and 20% wet basis (w.b.) moisture has a storage life of about 25 days. If it is dried to 18% w.b. after 12 days, half of its storage life has elapsed. Thus, the remaining storage life at 16°C and 18% w.b. moisture content is 25 days, not 50 days.

Insects thrive in stored grain if the moisture content and temperature are not properly controlled. At low moisture contents and temperatures below 10°C, insects remain dormant or die.

Most farm crops must be dried to, and maintained at, a suitable moisture content. For most grains, a suitable moisture content is in the range of 12 to 15% w.b., depending on the specific crop, storage temperature, and length of storage. Oilseeds such as peanuts, sunflower seeds, and flaxseeds must be dried to a moisture content of 8 to 9% w.b. Grain stored for more than a year, grain that is damaged,

and seed stock should be dried to a lower moisture content. Moisture levels above these critical values lead to the growth of fungi, which may produce toxic compounds such as aflatoxin.

The maximum yield of dry matter can be obtained by harvesting when the corn has dried in the field to an average moisture content of 26% w.b. However, for quality-conscious markets, the minimum damage occurs when corn is harvested at 21 to 22% w.b. Wheat can be harvested when it has dried to 20% w.b., but harvesting at these moisture contents requires expensive mechanical drying. Although field drying requires less expense than operating drying equipment, total cost may be greater because field losses generally increase as the moisture content decreases.

The price of grain to be sold through commercial market channels is based on a specified moisture content, with price discounts for moisture levels above the specified amount. These discounts compensate for the mass of excess water, cover the cost of water removal, and control the supply of wet grain delivered to market. Grain dried to below the base moisture content set by the market (15.0% w.b. for corn, 13.0% w.b. for soybeans, and 13.5% w.b. for wheat) is not generally sold at a premium; thus, the seller loses the opportunity to sell water for the price of grain.

**Grain Quantity**

The **bushel** is a volume measure (0.03524 m<sup>3</sup>) that is the common measure used for marketing grain in the United States, while the tonne (Mg) is the more common international measure. The legal mass for the bushel in the United States is set at 25.40 kg for corn and 27.22 kg for wheat. The densities of some crops are listed in [Table 2](#).

The percent of mass lost due to water removed may be calculated by the following equation:

$$\text{Moisture shrink, \%} = \frac{M_o - M_f}{100 - M_f} \times 100$$

where

$M_o$  = original or initial moisture content, wet basis  
 $M_f$  = final moisture content, wet basis

Applying the formula to drying a crop from 25% to 15%,

$$\text{Moisture shrink} = \frac{25 - 15}{100 - 15} \times 100 = 11.76\%$$

In this case, the moisture shrink is 11.76%, or an average 1.176% mass reduction for each percentage point of moisture reduction. The moisture shrink varies depending on the final moisture content. For example, the average shrink per point of moisture when drying from 20% to 10% is 1.111.

**Economics**

Producers generally have the choice of drying their grain on the farm before delivering it to market, or delivering wet grain with a price discount for excess moisture. The expense of drying on the farm

**Table 1 Approximate Allowable Storage Time (Days) for Cereal Grains**

Moisture Content, % w.b. <sup>a</sup>	Temperature, °C					
	-1	4	10	16	22	27
14	*	*	*	*	200	140
15	*	*	*	240	125	70
16	*	*	230	120	70	40
17	*	280	130	75	45	20
18	*	200	90	50	30	15
19	*	140	70	35	20	10
20	*	90	50	25	14	7
22	190	60	30	15	8	3
24	130	40	15	10	6	2
26	90	35	12	8	5	2
28	70	30	10	7	4	2
30	60	25	5	5	3	1

Based on composite of 0.5% maximum dry matter loss calculated on the basis of USDA research; *Transactions of ASAE* 333-337, 1972; and "Unheated Air Drying," Manitoba Agriculture Agdex 732-1, rev. 1986.

<sup>a</sup>Grain moisture content calculated as percent wet basis: (mass of water in a given amount of wet grain + mass of the wet grain) × 100.

\*Approximate allowable storage time exceeds 300 days.

The preparation of this chapter is assigned to TC 2.2, Plant and Animal Environment.

**Table 2** Calculated Densities of Grains and Seeds Based on U.S. Department of Agriculture Data

	Bulk Density, kg/m <sup>3</sup>
Alfalfa	768
Barley	614
Beans, dry	768
Bluegrass	180 to 384
Canola	643 to 770
Clover	768
Corn	
Ear, husked	448
Shelled	717
Cottonseed	410
Oats	410
Peanuts, unshelled	
Virginia type	218
Runner, Southeastern	269
Spanish	317
Rice, rough	576
Rye	717
Sorghum	640
Soybeans	768
Sudan grass	768
Sunflower	
Nonoil	307
Oilseed	410
Wheat	768

includes both fixed and variable costs. Once a dryer is purchased, the costs of depreciation, interest, taxes, and repairs are fixed and minimally affected by volume of crops dried. The costs of labor, fuel, and electricity vary directly with the volume dried. Total drying costs vary widely, depending on the volume dried, the drying equipment, and fuel and equipment prices. Energy consumption depends primarily on dryer type. Generally, the faster the drying speed, the greater the energy consumption (Table 3).

## 1. DRYING

### 1.1 DRYING EQUIPMENT AND PRACTICES

Contemporary crop-drying equipment depends on mass and energy transfer between the drying air and the product to be dried. The drying rate is a function of the initial temperature and moisture content of the crop, the air-circulation rate, the entering condition of the circulated air, the length of flow path through the products, and the time elapsed since the beginning of the drying operation. Outdoor air is frequently heated before it is circulated through the product. Heating increases the rate of heat transfer to the product, increases its temperature, and increases the vapor pressure of the product moisture. For more information on crop responses to drying, see Chapter 11 of the 2005 *ASHRAE Handbook—Fundamentals*.

Most crop-drying equipment consists of (1) a fan to move the air through the product, (2) a controlled heater to increase the ambient air temperature to the desired level, and (3) a container to distribute the drying air uniformly through the product. The exhaust air is vented to the atmosphere. Where climate and other factors are favorable, unheated air is used for drying, and the heater is omitted.

#### Fans

The fan selected for a given drying application should meet the same requirements important in any air-moving application. It must

**Table 3** Estimated Corn Drying Energy Requirement

Dryer Type	kJ/kg of Water Removed
Unheated air	2300 to 2800
Low temperature	2800 to 3500
Batch-in-bin, continuous-flow in-bin	3500 to 4700
High temperature	
Air recirculating	4200 to 5100
Without air recirculating	4700 to 7000
Combination drying, dryeration	3300 to 4200

*Note:* Includes all energy requirements for fans and heat.

deliver the desired amount of air against the static resistance of the product in the bin or column, the resistance of the delivery system, and the resistance of the air inlet and outlet.

Foreign material in the grain can significantly change the required air pressure in the following ways:

- Foreign particles larger than the grain (straw, plant parts, and larger seeds) reduce airflow resistance. The airflow rate may be increased by 60% or more.
- Foreign particles smaller than the grain (broken grain, dust, and small seeds) increase the airflow resistance. The effect may be dramatic, decreasing the airflow rate by 50% or more.
- The method used to fill the dryer or the agitation or stirring of the grain after it is placed in the dryer can increase pressure requirements by up to 100%. In some grain, high moisture causes less pressure drop than does low moisture.

Vaneaxial fans are normally recommended when static pressures are less than 0.75 kPa. Backward-curved centrifugal fans are commonly recommended when static pressures are higher than 1.0 kPa. Low-speed centrifugal fans operating at 1750 rpm perform well up to about 1.75 kPa, and high-speed centrifugal fans operating at about 3500 rpm have the ability to develop static pressure up to about 2.5 kPa. The in-line centrifugal fan consists of a centrifugal fan impeller mounted in the housing of an axial flow fan. A bell-shaped inlet funnels the air into the impeller. The in-line centrifugal fan operates at about 3450 rpm and has the ability to develop pressures up to 2.5 kPa on 6 kW or larger fans.

After functional considerations are made, the initial cost of the dryer fan should be taken into account. Drying equipment has a low percentage of annual use in many applications, so the cost of dryer ownership per unit of material dried is sometimes greater than the energy cost of operation. The same considerations apply to other components of the dryer.

#### Heaters

Most crop dryer heaters are fueled by either natural gas, liquefied petroleum gas, or fuel oil, though some electric heaters are used. Dryers using coal, biomass (e.g., corn cobs, stubble, or wood), and solar energy have also been built.

Fuel combustion in crop dryers is similar to combustion in domestic and industrial furnaces. Heat is transferred to the drying air either indirectly, by means of a heat exchanger, or directly, by combining the combustion gases with the drying air. Direct combustion heating is generally limited to natural gas or liquefied petroleum (LP) gas heaters. Most grain dryers use direct combustion. Indirect heating is sometimes used in drying products such as hay because of its greater fire hazard.

#### Controls

In addition to the usual temperature controls for drying air, all heated air units must have safety controls similar to those found on space-heating equipment. These safety controls shut off the fuel in case of flame failure and stop the burner in case of overheating or

excessive drying air temperatures. All controls should be set up to operate the machinery safely in the event of power failure.

## 1.2 SHALLOW-LAYER DRYING

### Batch Dryers

The batch dryer cycles through the loading, drying, cooling, and unloading of the grain. Fans force hot air through columns (typically 300 mm wide) or layers (600 to 1500 mm thick) of grain. Drying time depends on the type of grain and the amount of moisture to be removed. Some dryers circulate and mix the grain to prevent significant moisture content gradients from forming across the column. A circulation rate that is too fast or a poor selection of handling equipment may cause undue damage and loss of market quality. Batch dryers are suitable for farm operations and are often portable.

### Continuous-Flow Dryers

This type of self-contained dryer passes a continuous stream of grain through the drying chamber. Some dryers use a second chamber to cool the hot, dry grain before storage. Handling and storage equipment must be available at all times to move grain to and from the dryers. These dryers have cross-flow, concurrent flow, or counterflow designs.

**Cross-Flow Dryers.** A cross-flow dryer is a column dryer that moves air perpendicular to the grain movement. These dryers commonly consist of two or more vertical columns surrounding the drying and cooling air plenums. The columns range in thickness from 200 to 400 mm. Airflow rates range from 0.7 to 2.7 m<sup>3</sup>/s per cubic metre of grain. The thermal efficiency of the drying process increases as column width increases and decreases as airflow rate increases. However, moisture uniformity and drying capacity increase as airflow rate increases and as column width decreases. Dryers are designed to obtain a desirable balance of airflow rate and column width for the expected moisture content levels and drying air temperatures. Performance is evaluated in terms of drying capacity, thermal efficiency, and dried product moisture uniformity.

As with the batch dryer, a moisture gradient forms across the column because the grain nearest the inside of the column is exposed to the driest air during the complete cycle. Several methods minimize the problem of uneven drying.

One method uses turnflow devices that split the grain stream and move the inside half of the column to the outside and the outside half to the inside. Although effective, turnflow devices tend to plug if the grain is trashy. Under these conditions, a scalper/cleaner should be used to clean the grain before it enters the dryer.

Another method is to divide the drying chamber into sections and duct the hot air so that its direction through the grain is reversed in alternate sections. This method produces about the same effect as the turnflow method.

A third method is to divide the drying chamber into sections and reduce the drying air temperature in each section consecutively. This method is the least effective.

**Rack-Type Dryers.** In this special type of cross-flow dryer, grain flows over alternating rows of heated air supply ducts and air exhaust ducts (Figure 1). This action mixes the grain and alternates exposure to relatively hot drying air and air cooled by previous contact with the grain, promoting moisture uniformity and equal exposure of the product to the drying air.

**Concurrent-Flow Dryers.** In the concurrent-flow dryer, grain and drying air move in the same direction in the drying chamber. The drying chamber is coupled to a counterflow cooling section. Thus, the hottest air is in contact with the wettest grain, allowing the use of higher drying air temperatures (up to 230°C). Rapid evaporative cooling in the wettest grain prevents the grain temperature from reaching excessive levels. Because higher drying air temperatures are used, the energy efficiency is better than that

obtained with a conventional cross-flow dryer. In the cooling section, the coolest air initially contacts the coolest grain. The combination of drying and cooling chambers results in lower thermal stresses in the grain kernels during drying and cooling and, thus, a higher-quality product.

**Counterflow Dryers.** The grain and drying air move in opposite directions in the drying chamber of this dryer. Counterflow is common for in-bin dryers. Drying air enters from the bottom of the bin and exits from the top. The wet grain is loaded from overhead, and floor sweep augers can be used to bring the hot, dry grain to a center sump, where it is removed by another auger. The travel of the sweep is normally controlled by moisture- or temperature-sensing elements.

A drying zone exists only in the lower layers of the grain mass and is truncated at its lower edge so that the grain being removed is not overdried. As a part of the counterflow process, the warm, saturated or near-saturated air leaving the drying zone passes through the cool incoming grain. Some energy is used to heat the cool grain, but some moisture may condense on the cool grain if the bed is deep and the initial grain temperature is low.

### Reducing Energy Costs

**Recirculation.** In most commercially available continuous-flow dryers, optional ducting systems recycle some of the exhaust air from the drying and cooling chambers back to the inlet of the drying chamber (Figure 2). Systems vary, but most make it possible to recirculate all of the air from the cooling chamber and from the lower two-thirds of the drying chamber. The relative humidity of this recirculated air for most cross-flow dryers is less than 50%. Energy savings of up to 30% can be obtained from a well-designed system.

**Dryeration.** This is another means of reducing energy consumption and improving grain quality. In this process, hot grain with a moisture content one or two percentage points above that desired for storage is removed from the dryer (Figure 3). The hot grain is placed in a dryeration bin, where it tempers without airflow for at least 4 to 6 h. After the first grain delivered to the bin has tempered, the cooling fan is turned on as additional hot grain is delivered to the bin. The air cools the grain and removes 1 to 2% of its moisture before the grain is moved to final storage. If the cooling rate equals the filling rate, cooling is normally completed about 6 h after the last hot grain is added. The crop cooling rate should equal the filling rate of the dryeration bin. A faster cooling rate cools the grain before it has tempered. A slower rate may result in spoilage, since the allowable storage time for hot, damp grain may be only a few days. The required airflow rate is based on dryer capacity and crop density. An airflow rate of 0.2 m<sup>3</sup>/s for each cubic metre per hour of grain capacity provides cooling capacity to keep up with the dryer when drying

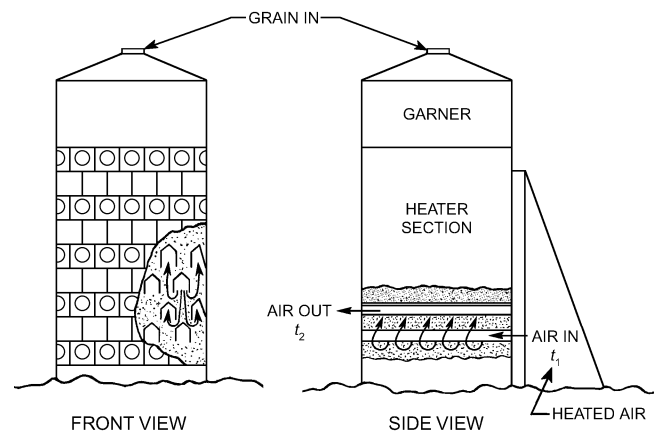

Fig. 1 Rack-Type Continuous-Flow Grain Dryer with Alternate Rows of Air Inlet and Outlet Ducts

corn that has a density of  $900 \text{ kg/m}^3$ . Recommended airflow rates for some crops are listed in Table 4.

**Combination Drying.** This method was developed to improve drying thermal efficiency and corn quality. First, a high-temperature dryer dries the corn to 18 to 20% moisture content. Then it is transferred to a bin, where the full-bin drying system brings the moisture down to a safe storage level.

**Dryer Temperature.** For energy savings, operating temperatures of batch and continuous-flow dryers are usually set at the highest level that will not damage the product for its end use.

### 1.3 DEEP-BED DRYING

A deep-bed drying system can be installed in any structure that holds grain. Most grain storage structures can be designed or adapted for drying if a means of distributing the drying air uniformly through the grain is provided. A perforated floor (Figure 4) and duct systems placed on the floor of the bin (Figure 5) are the two most common means.

Perforations in the floor should have a total area of at least 10% of the floor area. A perforated floor distributes air more uniformly and offers less resistance to airflow than do ducts, but a duct

system is less expensive for larger floor area systems. Ducts can be removed after the grain is removed, and the structure can be cleaned and used for other purposes. Ducts should not be spaced farther apart than one-half times the depth of the grain. The amount of perforated area or the duct length will affect airflow distribution uniformity.

Air ducts and tunnels that disperse air into the grain should be large enough to prevent the air velocity from exceeding  $10 \text{ m/s}$ ; slower speeds are desirable. Sharp turns, obstructions, or abrupt changes in duct size should be eliminated, as they cause pressure loss. Operating methods for drying grain in storage bins are (1) full-bin drying, (2) layer drying, (3) batch-in-bin drying, and (4) recirculating/continuous-flow bin drying.

### Full-Bin Drying

Full-bin drying is generally performed with unheated air or air heated up to  $11^\circ\text{C}$  above ambient. A humidistat is frequently used to sense the humidity of the drying air and turn off the heater if the weather conditions are such that heated air would cause overdrying. A humidistat setting of 55% stops drying at approximately the 12% moisture level for most farm grains, assuming that the ambient relative humidity does not go below this point.

Airflow rate requirements for full-bin drying are generally calculated on the basis of cubic metre per second of air required per cubic metre of grain. The airflow rate recommendations depend on the weather conditions and on the type of grain and its moisture content. Airflow rate is important for successful drying. Because faster drying results from higher airflow rates, the highest economical airflow rate should be used. However, the cost of full-bin drying at high airflow rates may exceed the cost of using column dryers, or the electric power requirement may exceed the available capacity.

Recommendations for full-bin drying with unheated air are shown in Tables 5, 6, and 7. These recommendations apply to the principal production areas of the continental United States and are based on experience under average conditions; they may not be applicable under unusual weather conditions or even usual weather conditions in the case of late-maturing crops. Full-bin drying may not be feasible in some geographical areas.

The maximum practical depth of grain to be dried (distance of air travel) is limited by the cost of the fan, motor, air distribution system, and power required. This depth seems to be  $6 \text{ m}$  for corn and soybeans, and about  $4.5 \text{ m}$  for wheat.

To ensure satisfactory drying, heated air may be used during periods of prolonged fog or rain. Burners should be sized to raise the temperature of the drying air by no more than  $6 \text{ K}$  above ambient.

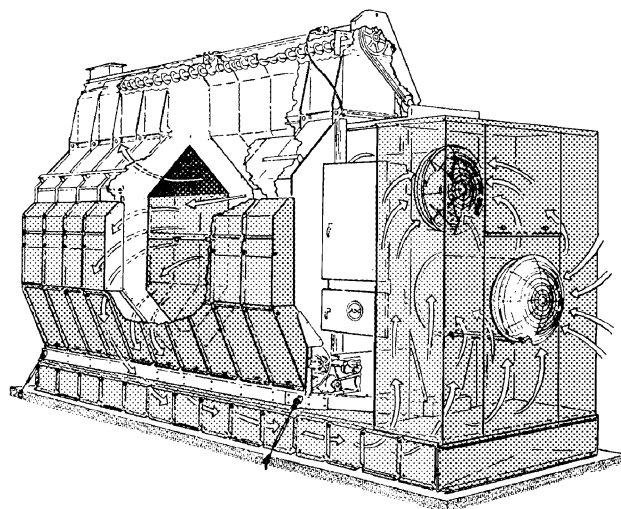

**Fig. 2 Crop Dryer Recirculation Unit**  
(Courtesy Farm Fans, Inc., a division of The GSI Group)

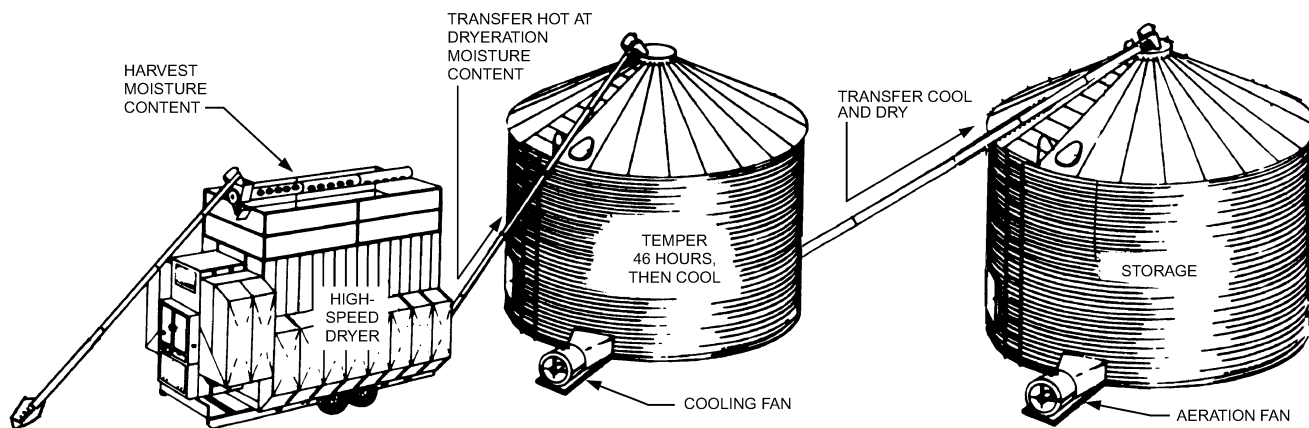

**Fig. 3 Dryeration System Schematic**

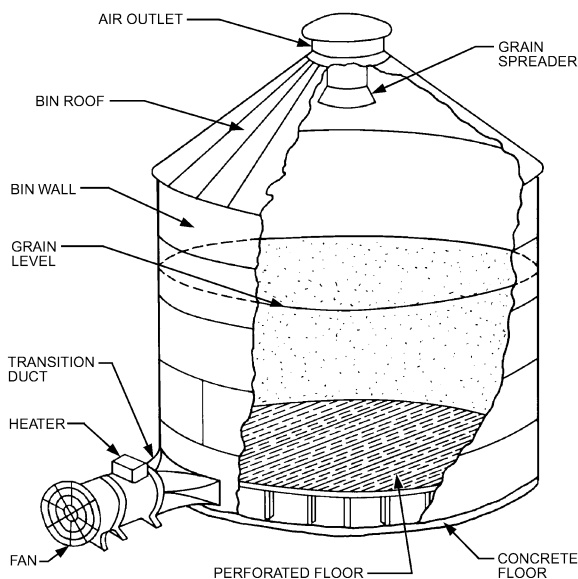

Fig. 4 Perforated Floor System for Bin Drying of Grain

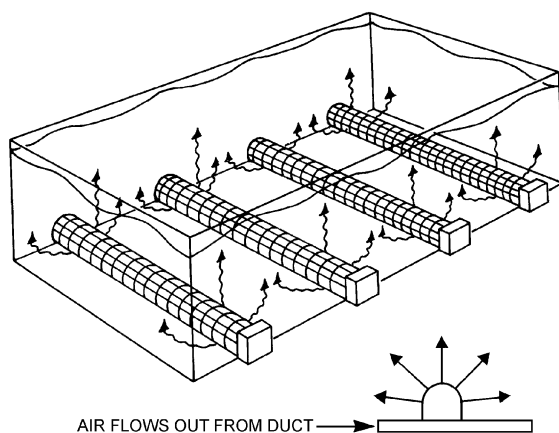

Fig. 5 Tunnel or Duct Air Distribution System

Table 4 Recommended Airflow Rates for Dryeration

Crop	Density, kg/m <sup>3</sup>	Recommended Dryeration Airflow Rate, m <sup>3</sup> /s per cubic metre per hour dryer capacity
Barley	768	0.17
Corn	896	0.20
Durum	960	0.21
Edible beans	960	0.21
Flaxseeds	896	0.20
Millet	800	0.18
Oats	512	0.11
Rye	896	0.20
Sorghum	896	0.20
Soybeans	960	0.21
Nonoil sunflower seeds	384	0.09
Oil sunflower seeds	512	0.11
Hard red spring wheat	960	0.21

Note: Basic air volume is 0.80 m<sup>3</sup>/kg.

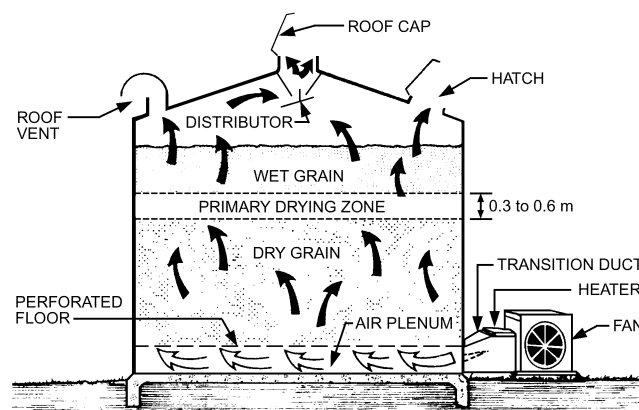

Fig. 6 Three Zones Within Grain During Full-Bin Drying

The temperature should not exceed about 27°C after heating. Overheating the drying air causes the grain to overdry and dry nonuniformly; heat is recommended only to counteract adverse weather conditions. Electric controllers can be applied to fan and heater operation to achieve the final desired grain moisture content.

Drying takes place in a drying zone, which advances upward through the grain (Figure 6). Grain above this drying zone remains at or slightly above the initial moisture content, while grain below the drying zone is at a moisture content in equilibrium with the drying air.

As the direction of air movement does not affect the rate of drying, other factors must be considered in choosing the direction. A pressure system moves the moisture-laden air up through the grain, and it is discharged under the roof. If there are insufficient roof outlets, moisture may condense on the underside of metal roofs. During pressure system ventilation, the wettest grain is near the top surface and is easy to monitor. Fan and motor waste heat enter into the airstream and contribute to drying.

A negative-pressure system moves air down through the grain. Moisture-laden air discharges from the fan to the outdoors; thus, roof condensation is not a problem. Also, the air picks up some solar heat from the roof. However, the wettest grain is near the bottom of the mass and is difficult to sample. Of the two systems, the pressure system is recommended because it is easier to manage.

The following management practices must be observed to ensure the best performance of the dryer:

1. Minimize foreign material. A scalper-cleaner is recommended for cleaning the grain to reduce air pressure and energy requirements and to help provide uniform airflow for elimination of wet spots.
2. Distribute the remaining foreign material uniformly by installing a grain distributor.
3. Place the grain in layers and keep it leveled.
4. Start the fan as soon as the floor or ducts are covered with grain.
5. Operate the fan continuously with unheated air unless it is raining heavily or there is a dense ground fog. Once all the grain is within 1% of desired storage moisture content, run the fans only when the relative humidity is below 70%.

### Layer Drying

In layer drying, successive layers of wet grain are placed on top of dry grain. When the top 150 mm has dried to within 1% of the desired moisture content, another layer is added (Figure 7). Compared to full-bin drying, layering reduces the time that the top layers of grain remain wet. Because the effective airflow rate is greater for lower layers, allowable harvest moisture content of grain in these levels can be

**Table 5 Maximum Corn Moisture Contents, Wet Mass Basis, for Single-Fill Unheated Air Drying**

Zone	Full-Bin Airflow Rate, m <sup>3</sup> /s per cubic metre of grain	Harvest Date						
		9-1	9-15	10-1	10-15	11-1	11-15	12-1
		Initial Moisture Content, %						
A	0.013	18	19.5	21	22	24	20	18
	0.017	20	20.5	21.5	23	24.5	20.5	18
	0.020	20	20.5	22.5	23	25	21	18
	0.027	20.5	21	23	24	25.5	21.5	18
	0.040	22	22.5	24	25.5	27	22	18
B	0.013	19	20	20	21	23	20	18
	0.017	19	20	20.5	21.5	24	20.5	18
	0.020	19.5	20.5	21	22.5	24	21	18
	0.027	20	21	22.5	23.5	25	21.5	18
	0.040	21	22.5	23.5	24.5	26	22	18
C	0.013	19	19.5	20	21	22	20	18
	0.017	19	20	20.5	21.5	22.5	20.5	18
	0.020	19.5	20	21	22	23.5	21.5	18
	0.027	20	21	22	23	24.5	21.5	18
	0.040	21	22	23.5	24.5	25.5	22	18
D	0.013	19	19.5	20	21	22	20	18
	0.017	19	19.5	20.5	21	22.5	20.5	18
	0.020	19	19.5	21	22	23	21	18
	0.027	19.5	21	21.5	23	24	21.5	18
	0.040	20.5	21.5	23	24	25	22	18

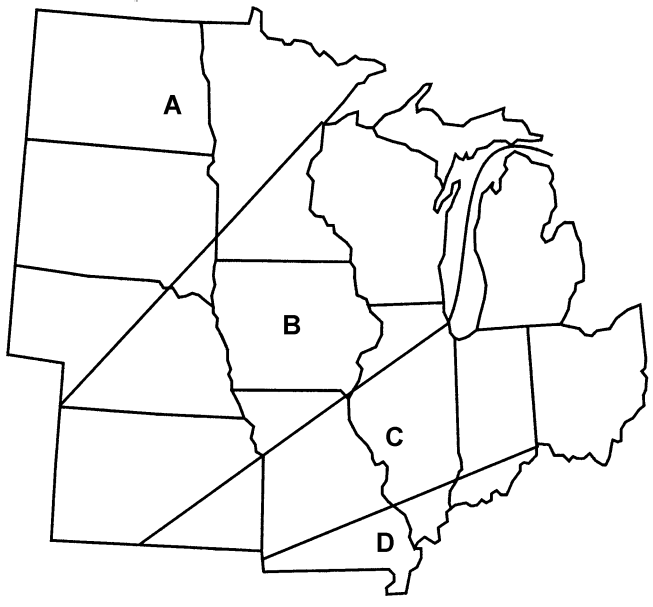

Source: Midwest Plan Service, 1980. Reprinted with permission.

**Table 6 Minimum Airflow Rate for Unheated Air Low-Temperature Drying of Small Grains and Sunflower in the Northern Plains of the United States**

Airflow Rate m <sup>3</sup> /s per cubic metre of grain	Maximum Initial Moisture Content, % Wet Basis	
	Small Grains	Sunflower
0.007	16	15
0.013	18	17
0.027	20	21

greater than that in the upper layers. Either unheated air or air heated 6 to 11°C above ambient may be used, but using heated air controlled with a humidistat to prevent overdrying is most common. The first layer may be about 2 m deep, with successive layers of about 1 m.

**Batch-in-Bin Drying**

A storage bin adapted for drying may be used to dry several batches of grain during a harvest season, if the grain is kept to a shallow layer so that higher airflow rates and temperatures can be used. After the batch is dry, the bin is emptied, and the cycle is repeated. The drying capacity of the batch system is greater than that of other in-storage drying systems. In a typical operation, batches of corn in 1 m depths are dried from an initial moisture content of 25% with 54°C air at the rate of about 0.33 m<sup>3</sup>/s per cubic metre. Considerable nonuniformity of moisture content may be present in the batch after drying is stopped; therefore, the grain should be well mixed as it is placed into storage. If the mixing is done well, grain that is too wet equalizes in moisture with grain that is too dry before spoilage can occur. Aeration of the grain in storage will facilitate the equalization of moisture.

Grain may be cooled in the dryer to ambient temperature before it is stored. Cooling is accomplished by operating the fan without the heater for about 1 h. Some additional drying occurs during the cooling process, particularly in the wetter portions of the batch.

**Grain stirring** devices are used with both full-bin and batch-in-bin drying systems. Typically, these devices consist of one or more

**Table 7 Recommended Unheated Air Airflow Rate for Different Grains and Moisture Contents in the Southern United States**

Type of Grain	Grain Moisture Content, %	Recommended Airflow Rate, m <sup>3</sup> /s per cubic metre of grain
Wheat	25	0.080
	22	0.067
	20	0.040
	18	0.027
	16	0.013
Oats	25	0.040
	20	0.027
	18	0.020
	16	0.013
Shelled Corn	25	0.067
	20	0.040
	18	0.027
	16	0.013
Ear Corn	25	0.107
	18	0.053
Grain Sorghum	25	0.080
	22	0.067
	18	0.040
	15	0.027
Soybeans	25	0.080
	22	0.067
	18	0.040
	15	0.027

Compiled from USDA Leaflet 332 (1952) and Univ. of Georgia Bulletin NS 33 (1958).

open, 50 mm diameter, standard pitch augers suspended from the bin roof and extending to near the bin floor. The augers rotate and simultaneously travel horizontally around the bin, mixing the drying grain to reduce moisture gradients and prevent overdrying of the bottom grain. The augers also loosen the grain, allowing a higher

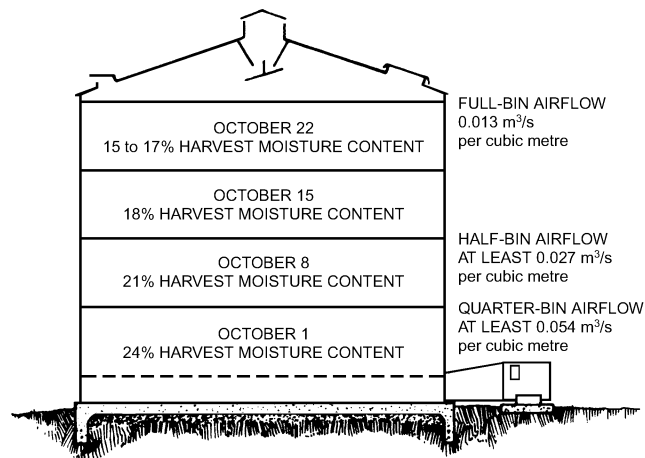

Fig. 7 Example of Layer Filling of Corn

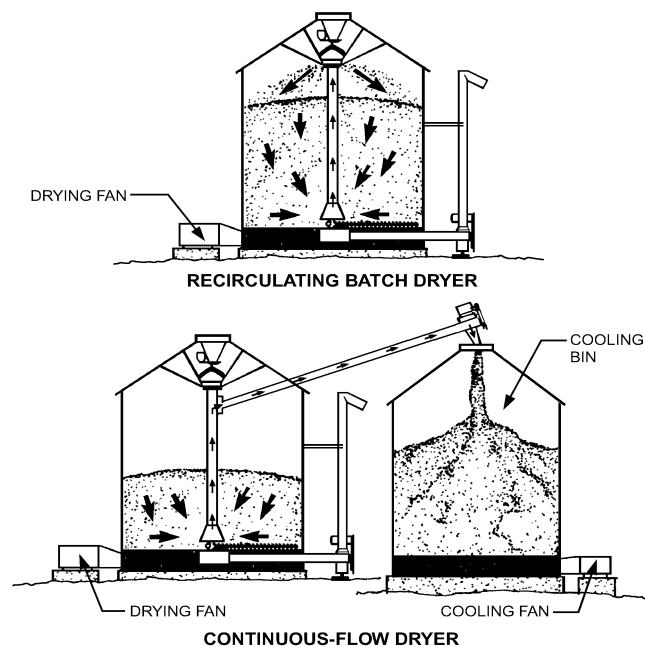

Fig. 8 Grain Recirculators Convert Bin Dryer to High-Speed Continuous-Flow Dryer

airflow rate for a given fan. Stirring equipment reduces bin capacity by about 10%. Furthermore, commercial stirring devices are available only for round storage enclosures.

### Recirculating/Continuous-Flow Bin Drying

This type of drying incorporates a tapered sweep auger that removes uniform layers of grain from the bottom of the bin as it dries (Figure 8). The dry grain is then redistributed on top of the pile of grain or moved to a second bin for cooling. The sweep auger may be controlled by temperature or moisture sensors. When the desired condition is reached, the sensor starts the sweep auger, which removes a layer of grain. After a complete circuit of the bin, the sweep auger stops until the sensor determines that another layer is dry. Some drying takes place in the cooling bin. Up to two percentage points of moisture may be removed, depending on the management of the cooling bin.

## 2. DRYING SPECIFIC CROPS

### 2.1 SOYBEANS

Soybeans usually need drying only when there is inclement weather during the harvest season. Mature soybeans left exposed to rain or damp weather develop a dark brown color and a mealy or chalky texture. Seed quality deteriorates rapidly. Oil from weather-damaged beans costs more to refine and is often not of edible grade. In addition to preventing deterioration, the artificial drying of soybeans offers the advantage of early harvest, which reduces the chance of loss from bad weather and reduces natural and combine shatter loss. Soybeans harvested with a wet basis moisture content greater than 13.5% exhibit less damage.

#### Drying Soybeans for Commercial Use

Conventional corn-drying equipment can be used for soybeans, with some limitations on heat input. Soybeans for commercial use can be dried at 55 to 60°C; drying temperatures of 90°C reduce the oil yield. If the relative humidity of the drying air is below 40%, excessive seedcoat cracking occurs, causing many split beans in subsequent handling. Physical damage can cause fungal growth on the beans, storage problems, and a slight reduction in oil yield and quality. Flow-retarding devices should be used during handling, and beans should not be dropped more than 6 m onto concrete floors.

#### Drying Soybeans for Seed and Food

The relative humidity of the drying air should be kept above 40%, regardless of the amount of heat used. The maximum drying temperature to avoid germination loss is 43°C. Natural air drying at a flow rate of 0.0267 m<sup>3</sup>/s per cubic metre is adequate for drying seed with an initial moisture content of up to 16% w.b.

If adding heat, raise the drying air temperature no more than 3 K above ambient. This drying method is slow, but it results in excellent quality and avoids overdrying. However, drying must be completed before spoilage occurs. At higher moisture contents, good results have been obtained using an airflow rate of 0.0534 m<sup>3</sup>/s per cubic metre with humidity control. Data on allowable drying time for soybeans are unavailable. Without better information, an estimate of storage life for oil crops can be made based on the values for corn, using an adjusted moisture content calculated by the following equation:

$$\text{Comparable moisture content} = \frac{\text{Oilseed moisture content}}{100 - \text{Seed oil content}} \times 100$$

A corn moisture content 2% greater than that of the soybeans should generally be used to estimate allowable drying time (e.g., 12% soybeans are comparable to 14% corn). Soybeans are dried from a lower initial moisture content than corn.

Dry high-moisture soybeans in a bin with the air temperature controlled to keep the relative humidity at 40% or higher. Airflow rates of 0.130 m<sup>3</sup>/s per cubic metre are recommended, with the depth of the beans not to exceed 1.2 m.

### 2.2 HAY

Hay normally contains 65 to 80% wet basis moisture at cutting. Field drying to 20% may result in a large loss of leaves. Alfalfa hay leaves average about 50% of the crop by mass, but they contain 70% of the protein and 90% of the carotene. The quality of hay can be increased and the risk of loss due to bad weather reduced if the hay is put under shelter when partially field dried (35% moisture content) and then artificially dried to a safe storage moisture content. In good drying weather, hay conditioned by

mechanical means can be dried sufficiently in one day and placed in the dryer. Hay may be long, chopped, or baled for this operation; unheated or heated air can be used.

### In-Storage Drying

Unheated air is normally used for in-storage or mow drying. Hay is dried in the field to 30 to 40% moisture content before being placed in the dryer. For unheated air drying, airflow should be at least  $0.10 \text{ m}^3/\text{s}$  per megagram. The fan should be able to deliver required airflow against static pressure of 250 to 500 Pa.

Slotted floors, with at least 50% of the area open, are generally used for drying baled hay. For long or chopped hay in mows narrower than 11 m wide, the center duct system is the most popular. A slotted floor should be placed on each side of the duct to within 1.5 m of its ends and the outer walls (Figure 9). If the mow is wider than 11 m, it should be divided crosswise into units of 8.5 m or narrower. These should then be treated as individual dryers. If the storage depth exceeds about 4 m, vertical flues and/or additional levels of ducts may be used. If tiered ducts are used, a vertical air chamber, about 75% of the probable hay depth, should be used. The supply ducts are then connected at 2 to 3 m vertical intervals as the mow is filled. With either of these methods, hay in total depths up to 9 m can be dried. The duct size should be such that the air velocity is less than 5 m/s.

The maximum depth of wet hay that should be placed on a hay-drying system at any time depends on hay moisture content, weather conditions, the physical form of the hay, and the airflow rate. The maximum drying depth is about 5 m for long hay, 4 m for chopped hay, and 7 small rectangular bales deep for baled hay. Baled hay should have a density of about  $130 \text{ kg/m}^3$ . For best results, bales should be stacked tightly together on edge (parallel to the stems) to ensure that no openings exist between them.

For mow drying, the fan should run continuously during the first few days. Afterward, it should be operated only during low relative humidity weather. During prolonged wet periods, the fan should be operated only enough to keep the hay cool.

### Batch Wagon Drying

Batch drying can be done on a slotted floor platform; however, because this method is labor-intensive, wagon dryers are more commonly used. With a wagon dryer system, hay is baled at about 45% moisture content to a density of about  $180 \text{ kg/m}^3$ . The hay is then stacked onto a wagon with tight, high sides and a slotted or expanded metal floor. Drying is accomplished most efficiently by forcing the heated air (up to  $70^\circ\text{C}$ ) down the canvas duct of a plenum chamber secured to the top of the wagon. After 4 or 5 h of drying, the exhaust air is no longer saturated with moisture, and

about 75% of it may be recirculated or passed through a second wagon of wet hay for greater drying efficiency.

In this method, the amount of hay harvested each day is limited by the capacity of the drying wagons. In this 24 h process, the hay cut one day is stored the following day; only enough hay to load the drying wagons should be harvested each day.

The airflow rate in this method is normally much higher than when unheated air is used. About  $0.2 \text{ m}^3/\text{s}$  per square metre of wagon floor space is required. As with mow drying, the duct size should be such that the air velocity is less than 5 m/s.

## 2.3 COTTON

Producers normally allow cotton to dry naturally in the field to 12% moisture content or less before harvest. Cotton harvested in this manner can be stored in trailers, baskets, or compacted stacks for extended periods with little loss in fiber or seed quality. Thus, cotton is not normally aerated or artificially dried before ginning. Cotton harvested during inclement weather and stored cotton exposed to precipitation must be dried at the cotton gin within a few days to prevent self heating and deterioration of the fiber and seed.

Though cotton may be safely stored at moisture contents as high as 12%, moisture levels near the upper limit are too high for efficient ginning and for obtaining optimum fiber grade. The cleaning efficiency of cotton is inversely proportional to its moisture content, with the most efficient level being 5% fiber moisture content. However, fiber quality is best preserved when the fiber is separated from the seed at moisture contents between 6.5 and 8%. Therefore, if cotton comes into the system below this level, it can be cleaned, but moisture should be added before separating the fiber from the seed to improve the ginning quality. Dryers in the cotton gins are capable of drying the cotton to the desired moisture level.

The tower dryer is the most commonly used among several types of commercially available dryers. This device operates on a parallel flow principle:  $0.015$  to  $0.025 \text{ m}^3/\text{s}$  of drying air per kilogram of cotton also serves as the conveying medium. As it moves through the dryer's serpentine passages, cotton impacts on the walls. This action agitates the cotton for improved drying and lengthens its exposure time. Drying time depends on many variables, but total exposure seldom exceeds 15 s. For extremely wet cotton, two stages of drying are needed for adequate moisture control.

Wide variations in initial moisture content dictate different drying amounts for each load of cotton. Rapid changes in drying requirements are accommodated by automatically controlling drying air temperature in response to moisture measurements taken before or after drying. These control systems prevent overdrying and reduce energy requirements. For safety and to preserve fiber quality, drying air temperature should not exceed  $177^\circ\text{C}$  in any portion of the drying system.

If the internal cottonseed temperature does not exceed  $60^\circ\text{C}$ , germination is unimpaired by drying. This temperature is not exceeded in a tower dryer; however, the moisture content of the seed after drying may be above the 12% level recommended for safe long-term storage. Wet cottonseed is normally processed immediately at a cottonseed oil mill. Cottonseed under the 12% level is frequently stored for several months before milling or delinting and treatment at a seed processing plant. The aeration that cools deep beds of stored cottonseed effectively maintains viability and prevents an increase in free fatty acid content. For aeration, ambient air is normally drawn downward through the bed at a rate of at least  $0.0004 \text{ m}^3/\text{s}$  per cubic metre of oil mill seed and  $0.0021 \text{ m}^3/\text{s}$  per cubic metre of planting seed.

## 2.4 PEANUTS

Peanuts normally have a moisture content of about 50% at the time of digging. Allowing the peanuts to dry on the vines in the

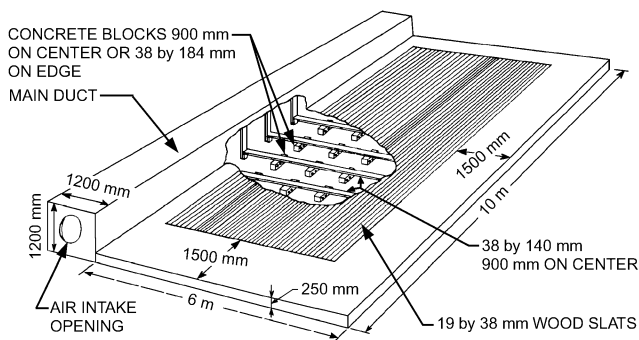

Fig. 9 Central Duct Hay-Drying System with Lateral Slatted Floor for Wide Mows

windrow for a few days removes much of this water. However, peanuts usually contain 20 to 30% moisture when removed from the vines, and some artificial drying is necessary. Drying should begin within 6 h after harvesting to keep the peanuts from self heating. Both the maximum temperature and the rate of drying must be carefully controlled to maintain quality.

High temperatures result in an off flavor or bitterness. Drying too rapidly without high temperatures results in blandness or nuts that do not develop flavor during roasting. High temperatures, rapid drying, or excessive drying cause the skin to slip easily and the kernels to become brittle. These conditions result in high damage rates in the shelling operation but can be avoided if the moisture removal rate does not exceed 0.5% per hour. Because of these limitations, continuous-flow drying is not usually recommended for peanuts.

Peanuts can be dried in bulk bins using unheated air or air with supplemental heat. Under poor drying conditions, unheated air may cause spoilage, so supplemental heat is preferred. Air should be heated no more than 7 to 8°C to a maximum temperature of 35°C. An airflow rate of 0.050 to 0.130 m<sup>3</sup>/s per cubic metre of peanuts should be used, depending on the initial moisture content.

The most common method of drying peanuts is bulk wagon drying. Peanuts are dried in depths of 1.5 to 1.8 m, using airflow rates of 0.05 to 0.08 m<sup>3</sup>/s per cubic metre of peanuts and air heated 6 to 8 K above ambient. This method retains quality and usually dries the peanuts in three to four days. Wagon drying reduces handling labor but may require additional investment in equipment.

## 2.5 RICE

Of all grains, rice is probably the most difficult to process without quality loss. Rice containing more than 13.5% moisture cannot be safely stored for long periods, yet the recommended harvest moisture content for best milling and germination ranges from 20 to 26%. When rice is harvested at this moisture content, drying must be started promptly to prevent souring. Normally, heated air is used in continuous-flow dryers, where large volumes of air are forced through 100 to 250 mm layers of rice. Temperatures as high as 55°C may be used, if (1) the temperature drop across the rice does not exceed 11 to 17 K, (2) the moisture reduction does not exceed two percentage points in a 0.5 h exposure, and (3) the rice temperature does not exceed 38°C. During the tempering period following drying, the rice should be aerated to ambient temperature before the next pass through the dryer. This removes additional moisture and eliminates one to two dryer passes. It is estimated that full use of aeration following dryer passes could increase the maximum daily drying capacity by about 14%.

Unheated air or air with a small amount of added heat (7 K above ambient, but not exceeding 35°C) should be used for deep-bed rice drying. Too much heat overdries the bottom, resulting in cracking, reduced milling qualities, and possible spoilage in the top. Because unheated air drying requires less investment and attention than supplemental heat drying, it is preferred when conditions permit. In the more humid rice-growing areas, supplemental heat is desirable to ensure that the rice dries. The time required for drying varies with weather conditions, moisture content, and airflow rate. In California, the recommended airflow rate is 0.001 to 0.012 m<sup>3</sup>/s per cubic metre. Because of less favorable drying conditions in Arkansas, Louisiana, and Texas, greater airflow rates are recommended (e.g., a minimum of 0.01 m<sup>3</sup>/s per cubic metre is recommended in Texas). Whether unheated air or supplemental heat is used, the fan should be turned on as soon as rice uniformly covers the air distribution system. The fan should then run continuously until the moisture content in the top 300 mm of rice is reduced to about 15%. At this point, the supplemental heat should be turned off. The rice can then be dried to a safe storage level by operating the fan only when the relative humidity is below 75%.

## 3. STORAGE PROBLEMS AND PRACTICES

### 3.1 MOISTURE MIGRATION

Redistribution of moisture generally occurs in stored grain when grain temperature is not controlled (Figure 10). Localized spoilage can occur even when the grain is stored at a safe moisture level. Grain placed in storage in the fall at relatively high temperatures cools nonuniformly through contact with the outer surfaces of the storage bin as winter approaches. Thus, the grain near the outer walls and roof may be at cool outdoor temperatures while the grain nearer the center is still nearly the same temperature it was at harvest. These temperature differentials induce air convection currents that flow downward along the outer boundaries of the porous grain mass and upward through the center. When the cool air from the outer regions contacts the warm grain in the interior, the air is heated and its relative humidity is lowered, increasing its capacity to absorb moisture from the grain. When the warm, humid air reaches the cool grain near the top of the bin, it cools again and transfers vapor to the grain. Under extreme conditions, water condenses on the grain. The moisture concentration near the center of the grain surface causes significant spoilage if moisture migration is uncontrolled. During spring and summer, the temperature gradients are reversed. The grain moisture content increases most at depths of 600 to 1200 mm below the surface. Daily variations in temperature do not cause significant moisture migration. Aside from seasonal temperature variations, the size of the grain mass is the most important factor in fall and winter moisture migration. In storages containing less than 35 m<sup>3</sup>, there is less trouble with moisture migration. The problem becomes critical in large storages and is aggravated by incomplete cooling of artificially dried grain. Artificially dried grain should be cooled to near ambient temperature soon after drying.

### 3.2 GRAIN AERATION

Aeration by mechanically moving ambient air through the grain mass is the best way to control moisture migration. Aeration systems are also used to cool grain after harvest, particularly in warmer climates where grain may be placed in storage at temperatures exceeding 38°C. After the harvest heat is removed, aeration may be continued in cooler weather to bring the grain to a temperature within 11 K of the coldest average monthly temperature. The temperature must be maintained below 10°C.

Aeration systems are not a means of drying because airflow rates are too low. However, in areas where the climate is favorable, carefully controlled aeration may be used to remove small amounts of moisture. Commercial storages may have pockets of higher-moisture grain if, for example, some batches of grain are delivered after a rain shower or early in the morning. Aeration can control heating damage in the higher-moisture pockets.

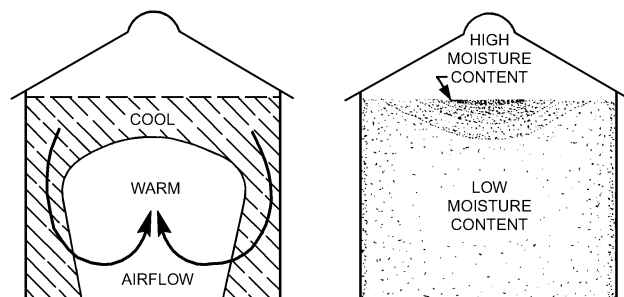

Fig. 10 Grain Storage Conditions Associated with Moisture Migration During Fall and Early Winter

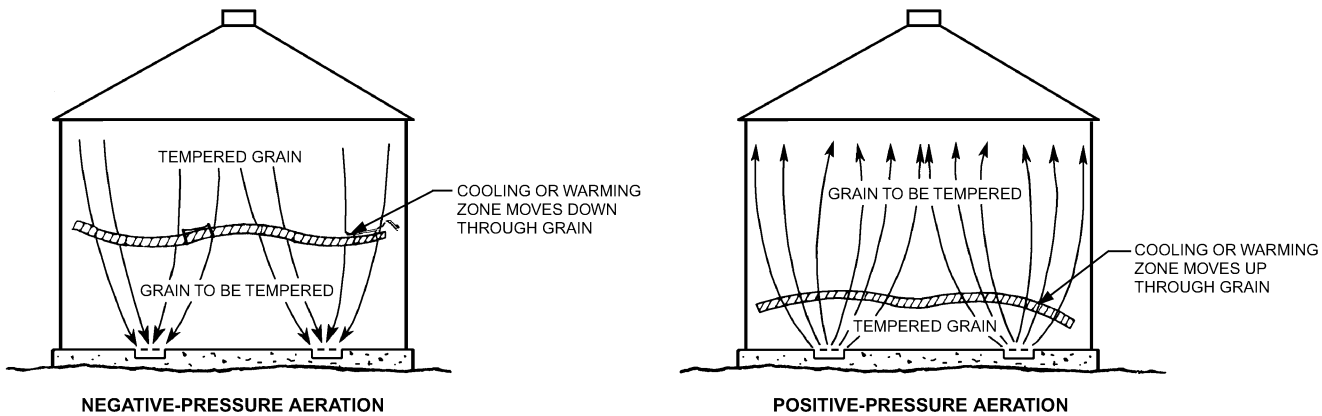

Fig. 11 Aerating to Change Grain Temperature

Table 8 Airflow Rates Corresponding to Approximate Grain Cooling Time

Airflow Rate, m <sup>3</sup> /s per cubic metre of grain	Cooling Time, h
0.0007	240
0.0013	120
0.0027	60
0.0040	40
0.0054	30
0.0067	24
0.0080	20
0.0107	15
0.0134	12

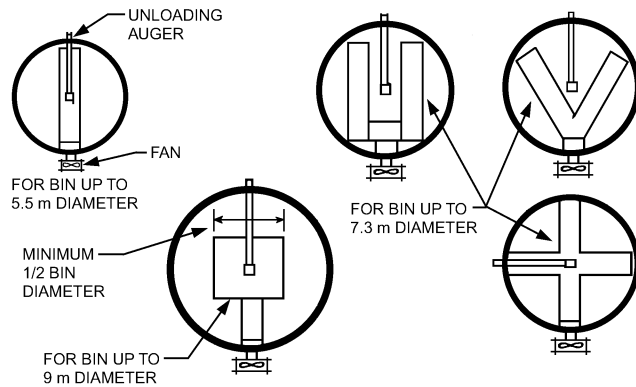

Fig. 12 Common Duct Patterns for Round Grain Bins

**Aeration Systems Design**

Aeration systems include fans capable of delivering the required amount of air at the required static pressure, suitable ducts or floors to distribute the air into the grain, and controls to regulate the operation of the fan. The airflow rate determines how many hours are required to cool the crop (Table 8). Most aeration systems are designed with airflow rates between 0.0007 to 0.0027 m<sup>3</sup>/s per cubic metre of grain.

Stored grain is aerated by forcing air up or down through the grain. Upward airflow is more common because it is easier to observe when the cooling front has moved through the entire grain mass. In large, flat storages with long ducts, upward airflow results in more uniform air distribution than downdraft systems.

During aeration, a warming or cooling front moves through the crop (Figure 11); it is important to run the fan long enough to move the front completely through the crop.

Static pressure for an aeration system can be determined using the airflow resistance information in Chapter 11 of the 2005 ASHRAE Handbook—Fundamentals. All common types of fans are used in aeration systems. Attention should be given to noise levels with fans that are operated near residential areas or where people work for extended periods. The supply ducts connecting the fan to the distribution ducts in the grain should be designed and constructed according to the standards of good practice for any air-moving application. A maximum air velocity of 13 m/s may be used, but 8 to 10 m/s is preferred. In large systems, one large fan may be attached to a manifold duct leading to several distribution ducts in one or more storages, or smaller individual fans may serve individual distribution ducts. Where a manifold is used, valves or dampers should be installed at each takeoff to allow adjustment or closure of airflow when part of the aerator is not needed.

Distribution ducts are usually perforated sheet metal with a circular or inverted U-shaped cross section, although many functional arrangements are possible. The area of the perforations should be at least 10% of the total duct surface. The holes should be uniformly spaced and small enough to prevent the passage of the grain into the duct (e.g., 2.5 mm holes or 2 mm wide slots do not pass wheat).

Since most problems develop in the center of the storage, and the crop cools naturally near the wall, the aeration system must provide good airflow in the center. Flush floor systems work well in storages with sweep augers and unloading equipment. Ducts should be easily removable for cleaning. Duct spacing should not exceed the depth of the crop; the distance between the duct and storage structure wall should not exceed one-half the depth of the crop for bins and flat storages. Common duct patterns for round bins are shown in Figure 12. Duct spacing for flat storages is shown in Figure 13.

When designing the distribution duct system for any type of storage, the following should be considered: (1) the cross-sectional area and length of the duct, which influences both the air velocity within the duct and the uniformity of air distribution; (2) the duct surface area, which affects the static pressure losses in the grain surrounding the duct; and (3) the distance between ducts, which influences the uniformity of airflow.

For upright storages where distribution ducts are relatively short, duct velocities up to 10 m/s are permissible. Maximum recommended air velocities in ducts for flat storages are shown in Table 9. Furthermore, these velocities should not be exceeded in the air outlets from the storage; therefore, an air outlet area at least equal to the duct cross-sectional area should be provided.

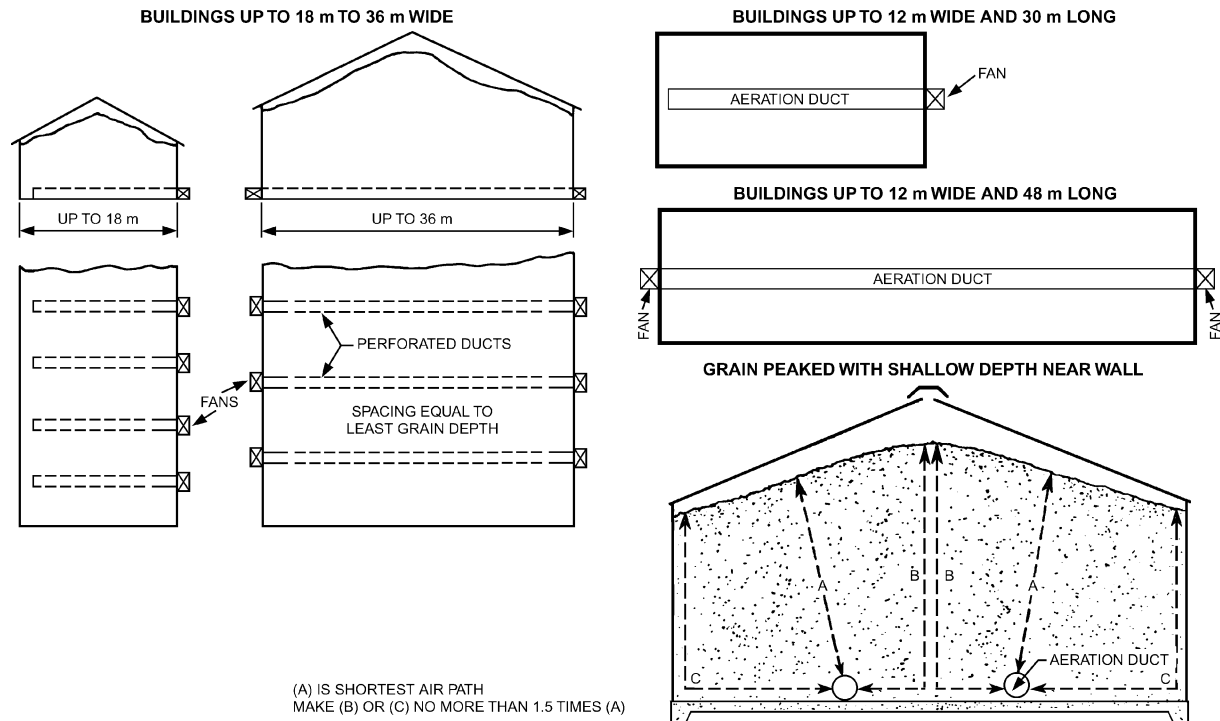

Fig. 13 Duct Arrangements for Large Flat Storages

The duct surface area that is perforated or otherwise open for air distribution must be great enough that the air velocity through the grain surrounding the duct is low enough to avoid excessive pressure loss. When a semicircular perforated duct is used, the entire surface area is effective; only 80% of the area of a circular duct resting on the floor is effective. For upright storages, the air velocity through the grain near the duct (duct face velocity) should be limited to 0.15 m/s or less; in flat storages, to 0.10 m/s or less.

Duct strength and anchoring are important. If ducts placed directly on the floor are to be held in place by the crop, the crop flow should be directly on top of the ducts to prevent movement and damage. Distribution ducts buried in the grain must be strong enough to withstand the pressure the grain exerts on them. In tall, upright storages, static grain pressures may reach 70 kPa. When ducts are located in the path of the grain flow, as in a hopper, they may be subjected to many times this pressure during grain unloading.

### Operating Aeration Systems

The operation of aeration systems depends largely on the objectives to be attained and the locality. In general, cooling should be carried out any time the outdoor air temperature is about 8 K cooler than the grain. Stored grain should not be aerated when the air humidity is much above the equilibrium humidity of the grain because moisture will be added. The fan should be operated long enough to cool the crop completely, but it should then be shut off and covered, thus limiting the amount of grain that is rewetted.

Aeration to cool the grain should be started as soon as the storage is filled, and cooling air temperatures are available. Aeration to prevent moisture migration should be started whenever the average air temperature is 6 to 8 K below the highest grain temperature. Aeration is usually continued as weather permits until the grain is uniformly cooled to within 11 K of the average temperature of the coldest month, or to 0 to 5°C.

Grain temperatures of about 0 to 10°C are desirable. In the northern corn belt, aeration may be resumed in the spring to equalize the grain temperature and raise it to between 5 to 10°C This

Table 9 Maximum Recommended Air Velocities Within Ducts for Flat Storages

Grain	Airflow Rate, m <sup>3</sup> /s per cubic metre (grain)	Air Velocity (m/s) within Ducts for Grain Depths of				
		3 m	6 m	9 m	12 m	15 m
Corn, soybeans, and other large grains	0.0007	—	3.8	5.0	6.3	6.3
	0.0013	3.8	5.0	6.3	7.6	8.8
	0.0027	5.0	6.3	—	—	—
Wheat, grain sorghum, and other small grains	0.0007	—	5.0	7.6	8.8	10.0
	0.0013	3.8	7.6	10.0	—	—
	0.0027	5.0	10.0	—	—	—

reduces the risk of localized heating from moisture migration. Storage problems are the only reason to aerate when air temperatures are above 15°C. Aeration fans and ducts should be covered when not in use.

In storages where fans are operated daily in fall and winter months, automatic controls work well when air is not too warm or humid. One thermostat usually prevents fan operation when the air temperature is too high, and another prevents operation when the air is too cold. A humidistat allows operation when the air is not too humid. Fan controllers that determine the equilibrium moisture content of the crop based on existing air conditions can regulate the fan based on entered information.

## 4. SEED STORAGE

Seed must be stored in a cool, dry environment to maintain viability. Most seed storages have refrigeration equipment to maintain a storage environment of 7 to 12°C. Seed storage conditions must be achieved before mold and insect damage occur.

### BIBLIOGRAPHY

- ASAE. 1993. Density, specific gravity, and mass-moisture relationships of grain for storage. ANSI/ASAE *Standard* D241.4. American Society of Agricultural Engineers (now American Society of Agricultural and Biological Engineers), St. Joseph, MI.
- ASAE. 1995. Moisture relationship of plant-based agricultural products. ASAE *Standard* D245.5. American Society of Agricultural Engineers (now American Society of Agricultural and Biological Engineers), St. Joseph, MI.
- ASAE. 1996. Resistance of airflow of grains, seeds, other agricultural products, and perforated metal sheets. ASAE *Standard* D272.2. American Society of Agricultural Engineers (now American Society of Agricultural and Biological Engineers), St. Joseph, MI.
- Brooker, D.B., F. Bakker-Arkema, and C. W. Hall. 1992. *Drying and storage of grains and oilseeds*. Van Nostrand, Reinhold, NY.
- MidWest Plan Service. 1988. *Grain drying, handling and storage handbook*. MWPS-13. Iowa State University, Ames.
- MidWest Plan Service. 1980. *Low temperature and solar grain drying handbook*. MWPS-22. Iowa State University, Ames.
- MidWest Plan Service. 1980. *Managing dry grain in storage*. AED-20. Iowa State University, Ames.
- Hall, C.A. 1980. *Drying and storage of agricultural crops*. AVI Publishing, Westport, CT.
- Hellevang, K.J. 1989. *Crop storage management*. AE-791. NDSU Extension Service, North Dakota State University, Fargo.
- Hellevang, K.J. 1987. *Grain drying*. AE-701. NDSU Extension Service, North Dakota State University, Fargo.
- Hellevang, K.J. 1983. *Natural air/low temperature crop drying*. EB-35. NDSU Extension Service, North Dakota State University, Fargo.
- Saver, D.B. (ed.) 1992. *Storage of cereal grains and their products*. American Association of Cereal Chemists, St. Paul, MN.
- Schuler, R.T, B.J. Holmes, R.J. Straub, and D.A. Rohweder. 1986. *Hay drying*. A3380. University of Wisconsin-Extension, Madison.