

**CHAPTER 48**

**NOISE AND VIBRATION CONTROL**

<i>DATA RELIABILITY</i> .....	48.1	<i>Equipment Vibration</i> .....	48.43
<i>ACOUSTICAL DESIGN OF HVAC SYSTEMS</i> .....	48.1	<i>Vibration Criteria</i> .....	48.43
<i>Receiver Considerations</i> .....	48.2	<i>Specification of Vibration Isolators</i> .....	48.45
<i>Basic Acoustical Design Techniques</i> .....	48.8	<i>Vibration- and Noise-Sensitive Facilities</i> .....	48.49
<i>Source Sound Levels</i> .....	48.8	<i>Internal Versus External Isolation</i> .....	48.49
<i>Path Noise Estimation and Control</i> .....	48.18	<i>Isolating Vibration and Noise in</i>	
<i>Receiver Room Sound Correction</i> .....	48.30	<i>Piping Systems</i> .....	48.50
<i>Sound Control for Outdoor Equipment</i> .....	48.33	<i>Seismic Protection</i> .....	48.52
<i>Fume Hood Duct Design</i> .....	48.34	<i>Vibration Investigations</i> .....	48.52
<i>Mechanical Equipment Room Sound Isolation</i> .....	48.35	<b>COMMISSIONING</b> .....	48.52
<i>HVAC Noise-Reduction Design Procedures</i> .....	48.38	<b>TROUBLESHOOTING</b> .....	48.52
<i>Vibration Isolation and Control</i> .....	48.41	<i>Determining Problem Source</i> .....	48.53
<i>Vibration Measurement</i> .....	48.42	<i>Determining Problem Type</i> .....	48.53

**H**VAC equipment for a building is one of the major sources of interior noise, and its effect on the acoustical environment is important. Also, noise from equipment located outdoors often propagates to the community. Therefore, mechanical equipment must be selected, and equipment spaces designed, with an emphasis on both the intended uses of the equipment and the goal of providing acceptable sound levels in occupied spaces of the building and in the surrounding community. Operation of HVAC equipment can also induce mechanical vibration that propagates into occupied spaces through structureborne paths such as piping, ductwork, and mounts. Vibration can cause direct discomfort and also create secondary radiation of noise from vibrating walls, floors, piping, etc.

In this chapter, *sound* and *noise* are used interchangeably, although only *unwanted* sound is considered to be noise.

System analysis for noise control uses the source-path-receiver concept. The source of the sound is the noise-generating mechanism. The sound travels from the source via a path, which can be through the air (airborne) or through the structure (structureborne), or a combination of both paths, until it reaches the receiver (building occupant or outdoor neighbor).

Components of the mechanical system (e.g., fans, dampers, diffusers, duct junctions) all may produce sound by the nature of the airflow through and around them. As a result, almost all HVAC components must be considered. Because sound travels effectively in the same or opposite direction of airflow, downstream and upstream paths are often equally important.

This chapter provides basic sound and vibration principles and data needed by HVAC system designers. Many of the equations associated with sound and vibration control for HVAC may be found in Chapter 8 of the 2013 *ASHRAE Handbook—Fundamentals*. Additional technical discussions along with detailed HVAC component and system design examples can be found in the references.

**1. DATA RELIABILITY**

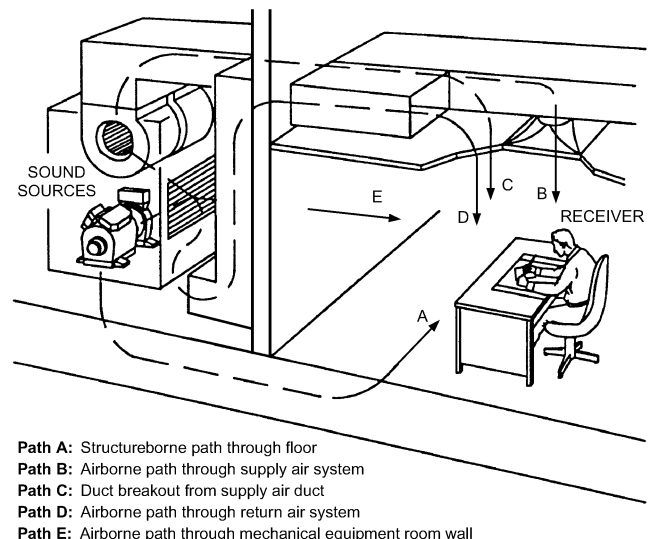
Data in this chapter come from both consulting experience and research studies. Use caution when applying the data, especially for situations that extrapolate from the framework of the original research. Test data tolerances and cumulative system effects lead to a typical uncertainty of  $\pm 2$  dB. However, significantly greater variations

may occur, especially in low frequency ranges and particularly in the 63 Hz octave band, where experience suggests that even correctly performed estimates may disagree with actual measured levels by 5 dB, so conservative design practices should be followed.

**2. ACOUSTICAL DESIGN OF HVAC SYSTEMS**

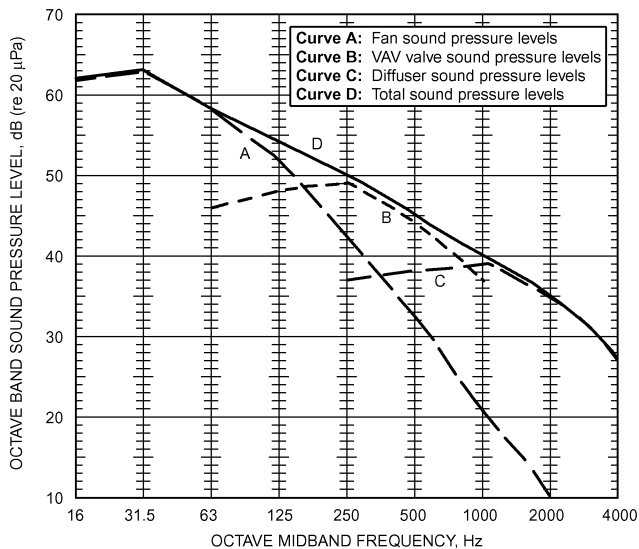
For most HVAC systems, sound sources are associated with the building’s mechanical and electrical equipment. As shown in [Figure 1](#), there are many possible paths for airborne and structureborne sound and vibration transmission between a sound source and receiver. Noise control involves (1) selecting a quiet source, (2) optimizing room sound absorption, and (3) designing propagation paths for minimal noise transmission.

Different sources produce sounds that have different frequency distributions, called **spectral characteristics**. For example, as shown in [Figure 2](#), fan noise generally contributes to sound levels in the 16 to 250 Hz octave bands (curve A). [Frequencies that designate

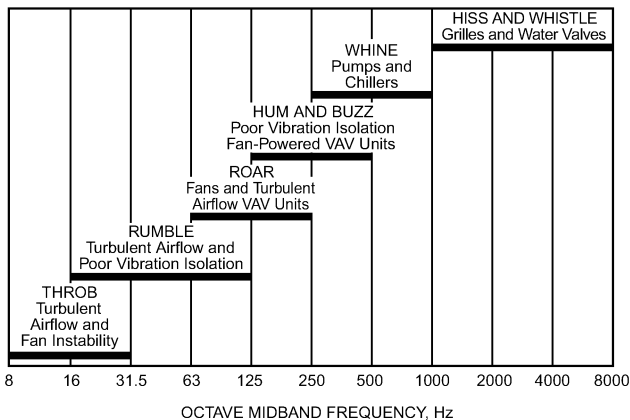


**Fig. 1 Typical Paths of Noise and Vibration Propagation in HVAC Systems**

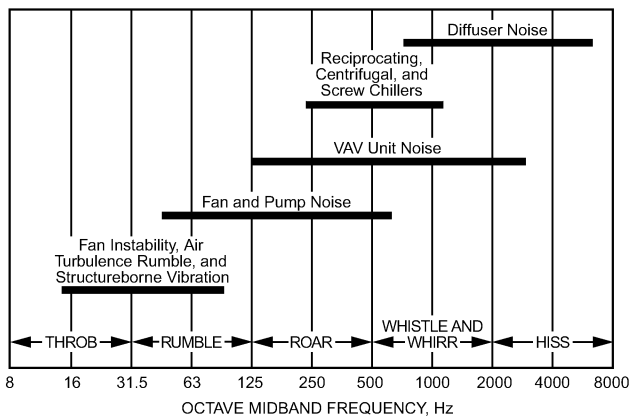
The preparation of this chapter is assigned to TC 2.6, Sound and Vibration Control.



**Fig. 2 HVAC Sound Spectrum Components for Occupied Spaces**



**Fig. 3 Frequency Ranges of Likely Sources of Sound-Related Complaints (Schaffer 2005)**



**Fig. 4 Frequencies at Which Different Types of Mechanical Equipment Generally Control Sound Spectra (Schaffer 2005)**

the octave bands are often called **octave midband** (or **center**) **frequencies**.) Variable-air-volume (VAV) valve noise usually contributes to sound levels in the 63 to 1000 Hz octave bands (curve B). Diffuser noise usually contributes to the overall HVAC noise in the 250 to 8000 Hz octave bands (curve C). The overall sound pressure level associated with all of these sound sources combined is shown as curve D.

Figure 3 (Schaffer 2005) shows the frequency ranges and descriptive terminology of the most likely sources of HVAC sound-related complaints. Figure 4 (Schaffer 2005) shows the frequencies at which different types of mechanical equipment generally control the sound spectra in a room. Occupant complaints may occur, however, despite a well-designed sound spectrum in the room. Criteria specified in this chapter do not necessarily correspond with all individuals' acceptability criteria.

**2.1 RECEIVER CONSIDERATIONS**

**Indoor Sound Criteria**

Whether an occupant considers the background noise acceptable generally depends on two factors. First is the **perceived loudness** of the noise relative to that of normal activities; if it is clearly noticeable, it is likely to be distracting and cause complaint. Second is the **sound quality** of the background noise; if the noise is perceived as a rumble, throb, roar, hiss, or tone, this may result in complaints of annoyance and stress. The frequency spectrum is then said to be unbalanced.

The acoustical design must ensure that HVAC noise is of sufficiently low level and unobtrusive quality so as not to interfere with occupancy use requirements. If background noise reduces speech intelligibility, for example, complaints of lost productivity can result. Accordingly, methods of rating HVAC-related noise ideally assess both perceived loudness and sound quality (Wang et al. 2013).

**Design Guidelines for HVAC-Related Background Sound in Rooms.** Table 1 presents recommended goals for indoor background noise levels in various types of unoccupied rooms served by HVAC systems. Perceived loudness and task interference are factored into the numerical part of the rating. The sound quality design target is assumed to be a neutral-sounding spectrum, although some spectral imbalance is probably tolerable within limits for most users. The criteria used are described in the next section.

An acceptable noise level depends on the specific use of the space, so each number rating typically represents a range of  $\pm 5$  dB for the design target. For example, private offices and conference rooms are listed as NC/RC 30. This means that unless there are extenuating circumstances, the background noise level should be less than NC/RC 35, but in some locations (e.g., executive offices or specialty conference rooms), a noise criterion of as low as NC/RC 25 might be warranted. On the other hand, there is not necessarily a benefit to achieving the lower number in regular offices, as some background noise maintains a minimum level of acoustic privacy between adjacent offices.

The NC/RC designations relate to reference curves with octave band sound pressure levels that are (1) selected based on appropriate loudness in the speech interference range (500 to 2000 Hz) and (2) show contours for high and low frequencies that are balanced at the same loudness level. Acoustical evaluation based on octave bands and target balanced contours is recommended, because overall dBA ratings do not reflect undesirable contributions of excessive low-frequency noise. The dBA and dBC levels are listed only as approximate references in the case of simplistic measurements, where dBA indicates relative loudness and dBC indicates prevalence of low-frequency noise. Exact specifications should be established by acoustical experts considering occupant sensitivity.

**Criteria Descriptions.** This section presents ways to rate or measure the sound to determine acceptability. The information

Licensed for single user. © 2015 ASHRAE, Inc.

Table 1 Design Guidelines for HVAC-Related Background Sound in Rooms

Room Types		Octave Band Analysis <sup>a</sup>		Approximate Overall Sound Pressure Level <sup>a</sup>	
		NC/RC <sup>b</sup>	dBA <sup>c</sup>	dBC <sup>c</sup>	
Rooms with Intrusion from Outdoor Noise Sources <sup>d</sup>	Traffic noise	N/A	45	70	
	Aircraft flyovers	N/A	45	70	
Residences, Apartments, Condominiums	Living areas	30	35	60	
	Bathrooms, kitchens, utility rooms	35	40	60	
Hotels/Motels	Individual rooms or suites	30	35	60	
	Meeting/banquet rooms	30	35	60	
	Corridors and lobbies	40	45	65	
	Service/support areas	40	45	65	
Office Buildings	Executive and private offices	30	35	60	
	Conference rooms	30	35	60	
	Teleconference rooms	25	30	55	
	Open-plan offices	40	45	65	
	Corridors and lobbies	40	45	65	
Courtrooms	Unamplified speech	30	35	60	
	Amplified speech	35	40	60	
Performing Arts Spaces	Drama theaters, concert and recital halls	20	25	50	
	Music teaching studios	25	30	55	
	Music practice rooms	30	35	60	
Hospitals and Clinics	Patient rooms	30	35	60	
	Wards	35	40	60	
	Operating and procedure rooms	35	40	60	
	Corridors and lobbies	40	45	65	
Laboratories	Testing/research with minimal speech communication	50	55	75	
	Extensive phone use and speech communication	45	50	70	
	Group teaching	35	40	60	
Churches, Mosques, Synagogues	General assembly with critical music programs <sup>e</sup>	25	30	55	
Schools <sup>f</sup>	Classrooms	30	35	60	
	Large lecture rooms with speech amplification	30	35	60	
	Large lecture rooms without speech amplification	25	30	55	
Libraries		30	35	60	
Indoor Stadiums, Gymnasiums	Gymnasiums and natatoriums <sup>g</sup>	45	50	70	
	Large-seating-capacity spaces with speech amplification <sup>g</sup>	50	55	75	

N/A = Not applicable

<sup>a</sup>Values and ranges are based on judgment and experience, and represent general limits of acceptability for typical building occupancies.

<sup>b</sup>NC: this metric plots octave band sound levels against a family of reference curves, with the number rating equal to the highest tangent line value.

RC: when sound quality in the space is important, the RC metric provides a diagnostic tool to quantify both the speech interference level and spectral imbalance.

<sup>c</sup>dBA and dBC: these are overall sound pressure level measurements with A- and C-weighting, and serve as good references for a fast, single-number measurement. They are also appropriate for specification in cases where no octave band sound data are available for design.

<sup>d</sup>Intrusive noise is addressed here for use in evaluating possible non-HVAC noise that is likely to contribute to background noise levels.

<sup>e</sup>An experienced acoustical consultant should be retained for guidance on acoustically critical spaces (below RC 30) and for all performing arts spaces.

<sup>f</sup>Some educators and others believe that HVAC-related sound criteria for schools, as listed in previous editions of this table, are too high and impede learning for affected groups of all ages. See ANSI/ASA *Standard* S12.60 for classroom acoustics and a justification for lower sound criteria in schools. The HVAC component of total noise meets the background noise requirement of that standard if HVAC-related background sound is approximately NC/RC 25. Within this category, designs for K-8 schools should be quieter than those for high schools and colleges.

<sup>g</sup>RC or NC criteria for these spaces need only be selected for the desired speech and hearing conditions.

should help the design engineer select the most appropriate background noise rating method for a specific project. Current methods described here and in other references include the traditional A-weighted sound pressure level (dBA) and tangent Noise Criteria (NC), the Room Criterion (RC) and more recent RC Mark II, the Balanced Noise Criterion (NCB), and the Room Noise Criteria (RNC). Each method was developed based on data for specific applications; hence, not all are equally suitable for rating HVAC-related noise in the variety of applications encountered. The preferred sound rating methods generally comprise two distinct parts: a family of criterion curves (specifying sound levels by octave bands), and a procedure for rating the calculated or measured sound data relative to the criterion curves with regard to sound quality.

Ideally, HVAC-related background noise should have the following characteristics:

- Balanced contributions from all parts of the sound spectrum with no predominant frequency bands of noise
- No audible tones such as hum or whine
- No fluctuations in level such as throbbing or pulsing

*dBA and dBC: A- and C-Weighted Sound Level.* The A-weighted sound level (described in Chapter 8 of the 2013 *ASHRAE Handbook—Fundamentals*) has been used for more than 60 years as a single-number measure of the relative loudness of noise, especially for outdoor environmental noise standards. The rating is expressed as a number followed by dBA (e.g., 40 dBA).

A-weighted sound levels can be measured with simple sound level meters. The ratings correlate fairly well with human judgments of relative loudness but take no account of spectral balance or sound quality. Thus, two different spectra can result in the same numeric value, but have quite different subjective qualities.

Along with dBA, there is also a C-weighted sound level, denoted as dBC, which is more sensitive to low-frequency sound contributions to the overall sound level than is dBA. When the quantity dBC – dBA is large (e.g., greater than 25 dB), significant low-frequency sound is present. It is recommended that when specifying background sound levels in dBA, the dBC is also included in the specification and does not exceed the dBA reading by more than 20 dB.

**NC: Noise Criteria Method.** The NC method for rating noise (described in Chapter 8 of the 2013 *ASHRAE Handbook—Fundamentals*) has been used for more than 50 years. It is a single-number rating that is somewhat sensitive to the relative loudness and speech interference properties of a given noise spectrum. The method consists of a family of criterion curves, shown in Figure 5, extending from 63 to 8000 Hz, and a **tangency rating procedure**. The criterion curves define the limits of octave band spectra that must not be exceeded to meet occupant acceptance in certain spaces. The rating is expressed as NC followed by a number (e.g., NC 40). The octave midband frequency of the point at which the spectrum is tangent to the highest NC curve should also be reported [e.g. NC 40 (125 Hz)]. The NC values are formally defined only in 5 dB increments, with intermediate values determined by discretionary interpolation.

Widely used and understood, the NC method is sensitive to level but has the disadvantage that the tangency method used to determine the rating does not require that the noise spectrum precisely follow the balanced shape of the NC curves. Thus, sounds with different frequency content can have the same numeric rating, but rank differently on the basis of sound quality. With the advent of VAV systems, low-frequency content (i.e., below the 63 Hz octave band) is prevalent, and the NC rating method fails to properly address this issue (Ebbling and Blazier 1992). Consequently, if the NC method is

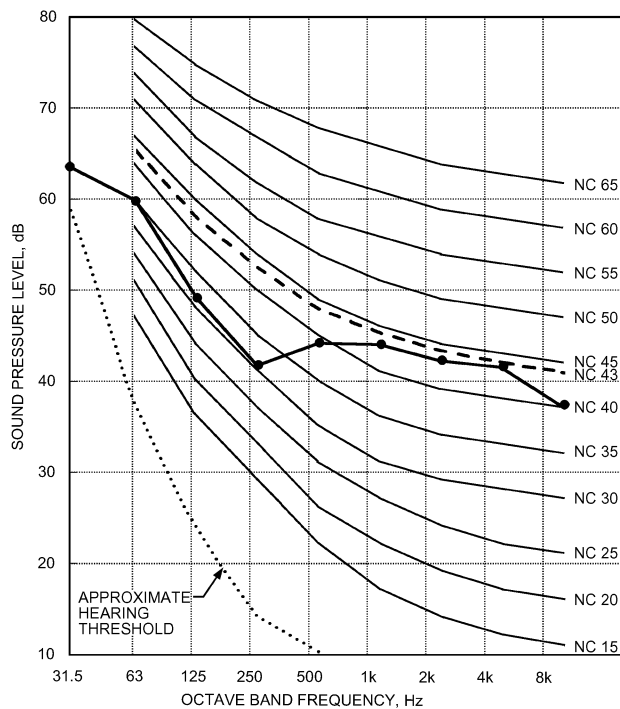


Fig. 5 Noise Criteria Curves

chosen, sound levels at frequencies below 63 Hz must be evaluated by other means.

In HVAC systems that do not produce excessive low-frequency noise and strong discernable pure tones, the NC rating correlates relatively well with occupant satisfaction if sound quality is not a significant concern. NC rating is often used because of its simplicity.

**RC/RC Mark II: Room Criteria Method.** ASHRAE previously recommended the Room Criterion (RC) curves (beginning in Chapter 43 in the 1995 *ASHRAE Handbook—HVAC Systems and Equipment*; Blazier 1981a, 1981b) as an enhanced method for rating HVAC system related noise. The revised RC Mark II method is now preferred.

The RC method is a family of criterion curves and a rating procedure. The shape of these curves represents a well-balanced, bland-sounding spectrum, including two additional octave bands (16 and 31.5 Hz) to deal with excessive low-frequency noise. This rating procedure assesses background noise in spaces on the basis of its effect on speech, and on subjective sound quality. The rating value is expressed as RC followed by a number that represents the level of noise in the speech interference region of the spectrum, and a letter to indicate the quality [e.g., RC 35(N), where N denotes the desirable neutral rating]. The RC method includes evaluation of the potential for noise-induced vibration from excessive airborne sound levels at and below 63 Hz.

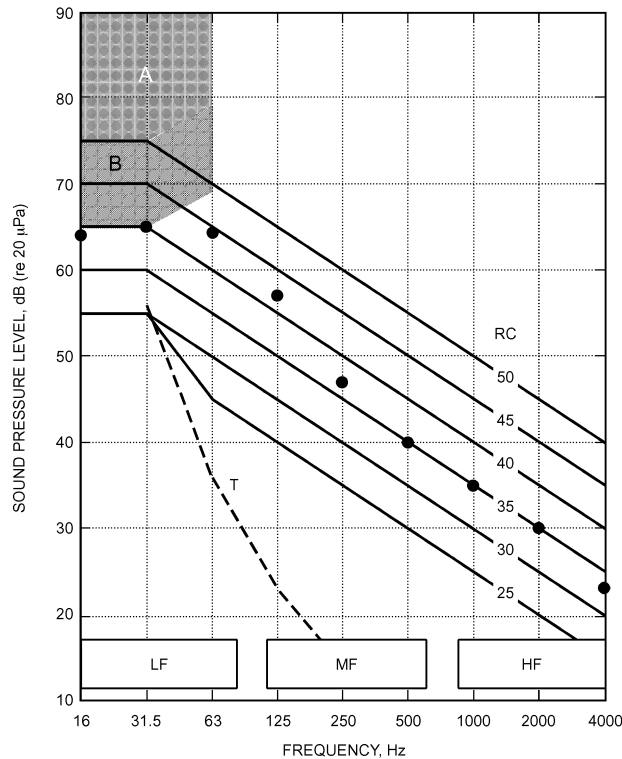
Based on experience and ASHRAE-sponsored research (Broner 1994), the RC method was revised to the RC Mark II method (Blazier 1997). Like its predecessor, the RC Mark II method is intended for use as a diagnostic tool for analyzing noise problems in the field. The RC Mark II method is complicated, but computerized spreadsheets and HVAC system analysis programs are available to perform the calculations and graphical analysis.

The RC Mark II method has three parts: (1) a family of criterion curves (Figure 6), (2) a procedure for determining the RC numerical rating and the noise spectral balance (quality), and (3) a procedure for estimating occupant satisfaction when the spectrum does not have the shape of an RC curve (quality assessment index) (Blazier 1995). The rating is expressed as RC followed by a number and a letter [e.g., RC 35(N)]. The number is the arithmetic average rounded to the nearest integer of sound pressure levels in the 500, 1000, and 2000 Hz octave bands (the main speech frequency region) and is known as the **preferred speech interference level (PSIL)**. The letter is a qualitative descriptor that identifies the sound's perceived character: (N) for neutral, (LF) for low-frequency rumble, (MF) for midfrequency roar, and (HF) for high-frequency hiss. There are also two subcategories of the low-frequency descriptor: (LF<sub>B</sub>), denoting a moderate but perceptible degree of sound-induced ceiling/wall vibration, and (LF<sub>A</sub>), denoting a noticeable degree of sound-induced vibration.

Each reference curve in Figure 6 identifies the shape of a neutral, bland-sounding spectrum, indexed to a curve number corresponding to the sound level in the 1000 Hz octave band. The shape of these curves is based on Blazier (1981a, 1981b), modified at 16 Hz following recommendations of the research in Broner (1994). Regions A and B denote levels at which sound can induce vibration in light wall and ceiling construction, which can potentially cause rattles in light fixtures, furniture, etc. Curve T is the octave band threshold of hearing as defined by ANSI Standard S12.2.

Procedure for Determining the RC Mark II Rating for a System.

**Step 1.** Obtain the arithmetic average of the sound levels in the principal speech frequency range represented by the levels in the 500, 1000, and 2000 Hz octave bands (PSIL). [This is not to be confused with the ANSI-defined "speech-interference level" (SIL), a four-band average obtained by including the 4000 Hz octave band as used with the NCB method.] The RC reference curve is chosen to



**Note:**  
 • Noise levels for lightweight wall and ceiling constructions:  
 – In shaded region B are likely to generate vibration that may be perceptible. There is a slight possibility of rattles in light fixtures, doors, windows, etc.  
 – In shaded region A have a high probability of generating easily perceptible noise-induced vibration. Audible rattling in light fixtures, doors, windows, etc. may be anticipated.  
 • Regions LF, MF, and HF are explained in the text.  
 • Solid dots are sound pressure levels for the example discussed in the text.

**Fig. 6 Room Criterion Curves, Mark II**

be that which has the same value at 1000 Hz as the calculated average value.

**Step 2.** Calculate the **quality assessment index (QAI)** (Blazier 1995), which measures the deviation of the spectrum under evaluation from the shape of the RC reference curve. Calculate the *energy-averaged* spectral deviations from the RC reference curve in each of three frequency groups: low (LF; 16 to 63 Hz), medium (MF; 125 to 500 Hz), and high (HF; 1000 to 4000 Hz). (A simple arithmetic average of these deviations is often adequate for most engineering purposes.) Equation (1) gives the procedure for the LF region; repeat for the MF and HF regions by substituting the corresponding values at each frequency.

$$LF = 10 \log[(10^{0.1\Delta L_{16}} + 10^{0.1\Delta L_{31.5}} + 10^{0.1\Delta L_{63}})/3] \quad (1)$$

The  $\Delta L$  terms are the differences between the spectrum being evaluated and the RC reference curve in each frequency band. In this way, three specific spectral deviation factors, expressed in dB with either positive or negative values, are associated with the spectrum being rated. QAI is the *range* in dB between the highest and lowest values of the spectral deviation factors.

If  $QAI \leq 5$  dB, the spectrum is assigned a *neutral* (N) rating. If QAI exceeds 5 dB, the sound quality descriptor of the RC rating is the letter designation of the frequency region of the deviation factor having the highest positive value.

**Example 1.** The spectrum plotted in Figure 6 indicated by large dots is processed in Table 2. The arithmetic average of the sound levels in the 500,

**Table 2 Example 1 Calculation of RC Mark II Rating**

	Frequency, Hz								
	16	31	63	125	250	500	1000	2000	4000
Spectrum levels	64	65	64	57	47	40	35	30	23
Average of 500 to 2000 Hz levels	35								
RC contour	60	60	55	50	45	40	35	30	25
Levels: RC contour	4	5	9	7	2	0	0	0	-2
Spectral deviations	LF			MF			HF		
	6.6			4.0			-0.6		
QAI	7.2								
RC Mark II rating	<b>RC 35(LF)</b>								

1000, and 2000 Hz octave bands is 35 dB, so the RC 35 curve is selected as the reference for spectrum quality evaluation.

The spectral deviation factors in the LF, MF, and HF regions are 6.6, 4.0, and -0.6 respectively, giving a QAI of 7.2. The maximum positive deviation factor occurs in the LF region and QAI exceeds 5; therefore, the rating of the spectrum is RC 35(LF). An average room occupant should perceive this spectrum as rumbly in character.

**Estimating Occupant Satisfaction Using QAI.**

The QAI estimates the probable reaction of an occupant when system design does not produce optimum sound quality. The basis for estimating occupant satisfaction is that changes in sound level of less than 5 dB do not cause subjects to change their ranking of sounds of similar spectral content. However, level changes greater than 5 dB do significantly affect subjective judgments. A QAI of 5 dB or less corresponds to a generally acceptable condition, provided that the perceived level of the sound is in a range consistent with the given type of space occupancy as recommended in Table 2. (An exception to this rule is when sound pressure levels in the 16 or 31 Hz octave bands exceed 65 dB. In such cases, there is potential for acoustically induced vibration in typical low-mass office construction. Levels above 75 dB in these bands indicate a significant problem with induced vibration.)

A QAI that exceeds 5 dB but is less than or equal to 10 dB represents a marginal situation, in which acceptance by an occupant is questionable. However, a QAI greater than 10 dB will likely be objectionable to the average occupant. Table 3 lists sound quality descriptors and QAI values and relates them to probable occupant reaction to the noise.

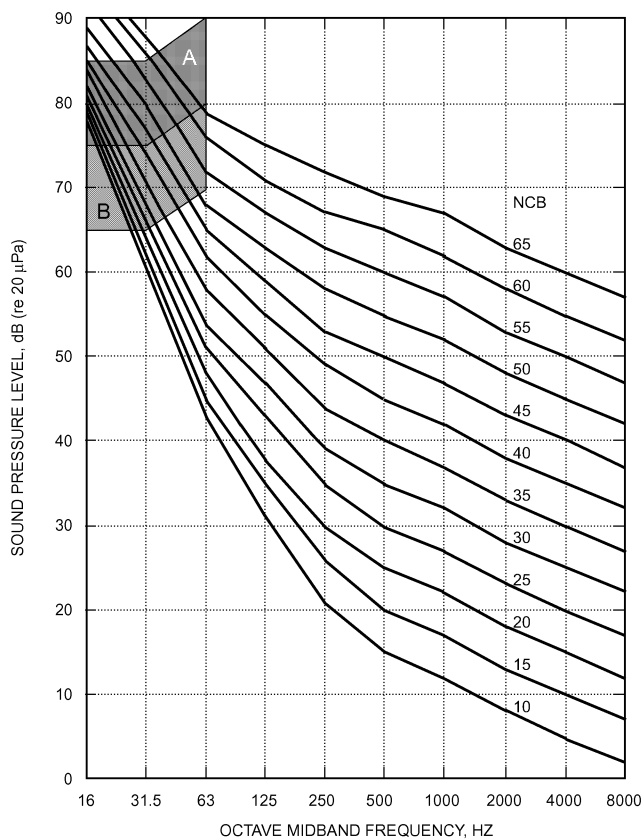
The numerical part of the RC rating may sometimes be less than the specified maximum for the space use, but with a sound quality descriptor other than the desirable (N). For example, a maximum of RC 40(N) is specified, but the actual noise environment turns out to be RC 35(MF). There is insufficient knowledge in this area to decide which spectrum is preferable.

Even at moderate levels, if the dominant portion of the background noise occurs at a very low frequency, some people can experience a sense of oppressiveness or depression in the environment (Persson-Wayne et al. 1997). Such a complaint may result after exposure to that environment for several hours, and thus may not be noticeable during a short exposure period.

*NCB: Balanced Noise Criteria Method.* The NCB method (ANSI Standard S12.2; Beranek 1989) is used to specify or evaluate room noise, including that from occupant activities. The NCB criterion curves (Figure 7) are intended as an improvement over the NC curves by including the two low-frequency octave bands (16 and 31.5 Hz), and by lowering permissible noise levels at high frequencies (4000 and 8000 Hz). Rating is based on the speech interference level (SIL = the average of the four sound pressure levels at octave midband frequencies of 500, 1000, 2000, and 4000 Hz) with additional tests for rumble and hiss compliance. The rating is expressed as NCB followed by a number (e.g., NCB 40).

**Table 3** Definition of Sound-Quality Descriptor and Quality-Assessment Index (QAI), to Aid in Interpreting RC Mark II Ratings of HVAC-Related Sound

Sound-Quality Descriptor	Description of Subjective Perception	Magnitude of QAI	Probable Occupant Evaluation, Assuming Level of Specified Criterion is Not Exceeded
(N) Neutral (Bland)	Balanced sound spectrum, no single frequency range dominant	$QAI \leq 5$ dB, $L_{16}, L_{31} \leq 65$	Acceptable
		$QAI \leq 5$ dB, $L_{16}, L_{31} > 65$	Marginal
(LF) Rumble	Low-frequency range dominant (16 to 63 Hz)	$5$ dB $< QAI \leq 10$ dB	Marginal
		$QAI > 10$ dB	Objectionable
(LFV <sub>B</sub> ) Rumble, with moderately perceptible room surface vibration	Low-frequency range dominant (16 to 63 Hz)	$QAI \leq 5$ dB, $65 < L_{16}, L_{31} < 75$	Marginal
		$5$ dB $< QAI \leq 10$ dB	Marginal
		$QAI > 10$ dB	Objectionable
(LFV <sub>A</sub> ) Rumble, with clearly perceptible room surface vibration	Low-frequency range dominant (16 to 63 Hz)	$QAI \leq 5$ dB, $L_{16}, L_{31} > 75$	Marginal
		$5$ dB $< QAI \leq 10$ dB	Marginal
		$QAI > 10$ dB	Objectionable
(MF) Roar	Mid-frequency range dominant (125 to 500 Hz)	$5$ dB $< QAI \leq 10$ dB	Marginal
		$QAI > 10$ dB	Objectionable
(HF) Hiss	High-frequency range dominant (1000 to 4000 Hz)	$5$ dB $< QAI \leq 10$ dB	Marginal
		$QAI > 10$ dB	Objectionable

**Fig. 7** NCB Noise Criterion Curves

The NCB method is better than the NC method in determining whether a noise spectrum has an unbalanced shape sufficient to demand corrective action, and it addresses the issue of low-frequency noise. Rating is, however, more complicated than the familiar NC tangency method. The NCB method can still be used as a tangency method; if so used, the point of tangency, which sets the rating, must be cited.

**RNC: Room Noise Criteria Method.** This rating method has been recently introduced and is described in detail in the American National Standards Institute (ANSI) *Standard* S12.2-2008. It is

mentioned here for reference only and, at present, ASHRAE has no formal position on the use of this method.

**Table 4** summarizes the essential differences, advantages, and disadvantages of rating methods used to characterize HVAC-related background noise. Unfortunately, at this time there is no acceptable and simple process to characterize the effects of audible tones and level fluctuations, so none of these rating methods address these issues.

**Noise Criteria for Plumbing Systems.** Acceptable noise levels from plumbing fixtures and piping have not been widely identified in the literature, except in ANSI/ASA *Standard* S12.60. Continuous noise from plumbing fixtures and piping systems with circulating fluids should meet the same noise criteria as HVAC systems. However, many sounds from plumbing fixtures and piping are of short duration or are transient, and typically have a somewhat higher threshold of acceptance. Examples of these sources include water flow noise associated with typical restroom fixtures; noise from waste lines connected to restroom, kitchen, and/or laundry drains; and noise from jetted bathtubs.

**Table 5** presents suggested maximum A-weighted sound pressure levels for various transient plumbing noise sources in buildings with multiple occupancies. These criteria are minimum standards and are intended to apply to plumbing systems serving adjacent and nearby units in multifamily housing projects (apartments and condominiums), hospitals, educational facilities, and office buildings. Plumbing noise levels in luxury condominiums or private homes should be 5 to 10 dB lower than levels shown in **Table 5**.

Achieving the recommended plumbing noise criteria in the finished space usually requires special attention to pipe installation details, selection of suitable piping materials, design flow velocities, and selection of appropriate fixtures.

**Determining Compliance.** When taking field measurements to determine whether a space complies with the guidelines presented in **Table 1**, follow ANSI/ASA *Standard* S12.72 and note these precautions:

- Measure the noise with an integrating sound level meter with a real-time frequency analyzer meeting type 1 or 2 specifications, as defined in ANSI *Standards* S1.4 and S1.11. The meter should have been calibrated by an accredited calibration laboratory, with some assurance that the calibration accuracy has been maintained.
- Set the meter to display and save the equivalent energy sound pressure level  $L_{eq}$  with the desired frequency filtering (e.g., octave bands, A-weighted, etc.). Each measurement should be a minimum of 15 s long.

Table 4 Comparison of Sound Rating Methods

Method	Overview	Considers Speech Interference Effects	Evaluates Sound Quality	Components Presently Rated by Each Method
dBA	No quality assessment Frequently used for outdoor noise ordinances	Yes	No	Cooling towers Water chillers Condensing units
NC	Can rate components Limited quality assessment Does not evaluate low-frequency rumble	Yes	Somewhat	Air terminals Diffusers
RC Mark II	Used to evaluate systems Should not be used to evaluate components Evaluates sound quality Provides improved diagnostics capability	Yes	Yes	Not used for component rating
NCB	Can rate components Some quality assessment	Yes	Somewhat	See NC
RNC	Some quality assessment Attempts to quantify fluctuations	Yes	Somewhat	Not used for component rating

Table 5 Plumbing Noise Levels

Receiving (listening) room	$L_{max}$ (slow response)
Residential bedroom/living room/dining room	35
Hospital patient room/classroom	40
Private office/conference room	40
Residential bathroom/kitchen	45
Open office/lobby/corridor	50

- Place the measurement microphone in potential listening locations at least 1 m from room boundaries and noise sources and at least 0.5 m from furniture. More than one location may be measured, and the microphone may be moved during measurement; movement should not exceed 0.15 m/s.
- Note the operational conditions of the HVAC system at the time of the test. Turn off all non-HVAC system noises during the test. If possible, measure in a normally furnished, unoccupied room.
- The test may be repeated with the entire HVAC system turned off, to determine whether the room's ambient noise level from non-HVAC sources is contributing to the results.
- Record the sound level meter make, model, and serial number; measured sound pressure levels for each microphone location; HVAC system's operating conditions; and microphone location(s).

When these levels are used as a basis for compliance verification, the following additional information must be provided:

- What sound metrics are to be measured (specify  $L_{eq}$  or  $L_{max}$  levels, etc., in each octave frequency band)
- Where and how the sound levels are to be measured (specify the space average over a defined area or specific points for a specified minimum time duration, etc.)
- What type(s) of instruments are to be used to make the sound measurements (specify ANSI or IEC Type 1 or Type 2 sound level meters with octave band filters, etc.)
- How sound measurements instruments are to be calibrated or checked (specify that instruments are to be checked with an acoustical calibrator both before and after taking sound level measurements, etc.)
- How sound level measurements are to be adjusted for the presence of other sound sources (specify that background sound level measurements be performed without other sound sources under consideration operating; if background sound levels are within 10 dB of operational sound levels, then corrections should be performed; etc.)
- How results of sound measurements are to be interpreted (specify whether octave band sound levels, NC, RC, dBA, dBC or other values are to be reported)

Unless these six points are clearly stipulated, the specified sound criteria may be unenforceable.

When applying the levels specified in Table 1 as a basis for design, sound from non-HVAC sources, such as traffic and office equipment, may establish the lower limit for sound levels in a space.

### Outdoor Sound Criteria

Acceptable outdoor sound levels are generally specified by local noise ordinances or other government codes, which almost always use the A-weighted noise level (dBA) as their metric. The usual metric is either  $L_{max}$  (maximum noise level over a period) or  $L_{eq}$  (average noise level over a period). The time constant (FAST or SLOW) used for  $L_{max}$  or  $L_p$  depends on the code.

Some communities have no ordinance and depend on state regulations that often use the day/night noise level descriptor  $L_{DN}$ , which is a combination of the daytime (7:00 AM to 10:00 PM) and nighttime (10:00 PM to 7:00 AM) average noise levels ( $L_{eq}$ ) with a 10 dB penalty for nighttime. Other descriptors also exist; specific requirements should be identified at the outset of each project. In some cases, regulatory agencies may also impose project-specific noise conditions on the basis of community reaction and for maintaining an appropriate acoustic environment at the project vicinity.

Measurement or estimation of community noise is based on a location, often at the receiver's property line, from a height of approximately 1.2 m that represents ear height for a typical person seated at ground level to any height to address upper-floor elevations, but can be anywhere within the property line, and often near the façade of the closest dwelling unit. Alternatively, the measurement may be made at the property line of the noise source.

In the absence of a local noise ordinance, county or state laws or codes or those of a similar community should be used. Even if activity noise levels do not exceed those specified by an ordinance, community acceptance is not ensured. Very low ambient levels or a noise source with an often-repeated, time-varying characteristic or strong tonal content may increase the likelihood of complaints. Without local ordinances, noise levels between 45 and 55 dBA may be considered in residential zones and 55 to 65 dBA in commercial zones. These are for outdoor use areas and, with standard building constructions, they also typically result in acceptable interior noise levels. Often, daytime noise levels (the period of daytime to be defined) are 10 dB higher than nighttime levels.

Although most ordinances are given as A-weighted pressure level, attenuation by distance, barriers, buildings, and atmosphere are all frequency dependent. Thus, A-weighted levels do not give an accurate estimation of noise levels at distances from the source. If A-weighted sound levels of sources must be determined by means other than measurement, then octave band or one-third octave band

measurements of source sound pressure level at a distance, or (preferably) sound power level, must be obtained before calculating the attenuation.

## 2.2 BASIC ACOUSTICAL DESIGN TECHNIQUES

To minimize sound transmitted from system components to occupied spaces, select fans and other related mechanical equipment and design air distribution systems considering the following:

- Design the air distribution system to minimize flow resistance and turbulence. High flow resistance increases required fan pressure, which results in higher noise being generated by the fan, especially at low frequencies. Turbulence also increases flow noise generated by duct fittings and dampers, especially at low frequencies.
- Select a fan to operate as near as possible to its rated peak efficiency when handling the required airflow and static pressure. Also, select a fan that generates the lowest possible noise at required design conditions. Using an oversized or undersized fan that does not operate at or near rated peak efficiency can substantially increase noise levels.
- Design duct connections at both fan inlet and outlet for uniform and straight airflow. Both turbulence (at fan inlet and outlet) and flow separation at the fan blades can significantly increase fan-generated noise. Turning vanes near fan outlets can also increase turbulence and noise, especially if airflow is not sufficiently uniform.
- Select duct silencers that do not significantly increase the required fan total static pressure. Silencers with static pressure losses of 90 Pa or less can minimize regenerated noise from silencer airflow.
- Place fan-powered mixing boxes associated with variable-volume air distribution systems away from noise-sensitive areas.
- Minimize flow-generated noise by elbows or duct branch takeoffs whenever possible by locating them at least four to five duct diameters from each other. For high-velocity systems, it may be necessary to increase this distance to up to 10 duct diameters in critical noise areas. Using flow straighteners or honeycomb grids, often called “egg crates,” in the necks of short-length takeoffs that lead directly to grilles, registers, and diffusers is preferred to using volume extractors that protrude into the main duct airflow.
- Keep airflow velocity in ducts serving sound-sensitive spaces as low as possible by increasing the duct size to minimize turbulence and flow-generated noise (see [Tables 8](#) and [9](#), in the section on Aerodynamically Generated Sound in Ducts).
- Duct transitions should not exceed an included expansion angle of 15°, or the resulting flow separation may produce rumble noise.
- Use turning vanes in large 90° rectangular elbows and branch takeoffs. This provides a smoother directional transition, thus reducing turbulence.
- Place grilles, diffusers, and registers into occupied spaces as far as possible from elbows and branch takeoffs.
- Minimize use of volume dampers near grilles, diffusers, and registers in acoustically critical situations.
- Vibration-isolate all reciprocating and rotating equipment connected to structure. Also, it is usually necessary to vibration-isolate mechanical equipment in the basement of a building as well as piping supported from the ceiling slab of a basement, directly below tenant space. It may be necessary to use flexible piping connectors and flexible electrical conduit between rotating or reciprocating equipment and pipes and ducts that are connected to the equipment.
- Vibration-isolate ducts and pipes, using spring and/or neoprene hangers for at least the first 15 m from vibration-isolated equipment.
- Use barriers near outdoor equipment when noise associated with the equipment will disturb adjacent properties. In normal practice,

barriers typically produce no more than 15 dB of sound attenuation in the midfrequency range. To be effective, the noise barrier must at least block the direct “line of sight” between the source and receiver.

[Table 6](#) lists several common sound sources associated with mechanical equipment noise. Anticipated sound transmission paths and recommended noise reduction methods are also listed. Airborne and/or structureborne sound can follow any or all of the transmission paths associated with a specified sound source. Schaffer (2005) has more detailed information in this area.

## 2.3 SOURCE SOUND LEVELS

Accurate acoustical analysis of HVAC systems depends in part on reliable equipment sound data. These data are often available from equipment manufacturers in the form of sound pressure levels at a specified distance from the equipment or, preferably, equipment sound power levels. Standards used to determine equipment and component sound data are listed at the end of this chapter.

When reviewing manufacturers’ sound data, obtain certification that the data have been obtained according to one or more of the relevant industry standards. If they have not, the equipment should be rejected in favor of equipment for which data have been obtained according to relevant industry standards. See Ebbing and Blazier (1998) for further information.

### Fans

**Prediction of Fan Sound Power.** The sound power generated by a fan performing at a given duty is best obtained from manufacturers’ test data taken under approved test conditions (*AMCA Standard 300* or *ASHRAE Standard 68/AMCA Standard 330*). Applications of air-handling products range from stand-alone fans to systems with various modules and attachments. These appurtenances and modules can have a significant effect on air-handler sound power levels. In addition, fans of similar aerodynamic performance can have significant acoustical differences.

Predicting air-handling unit sound power from fan sound levels is difficult. Fan sound determined by tests may be quite different once the fan is installed in an air handler, which in effect creates a new acoustical environment. Proper testing to determine resulting sound power levels once a fan is installed is essential. Fan manufacturers are in the best position to supply information on their products, and should be consulted for data when evaluating the acoustic performance of fans for an air handler application. Similarly, air handler manufacturers are in the best position to supply acoustic information on air handlers.

Air handler manufacturers typically provide discharge, inlet, and casing-radiated sound power levels for their units based on one of two methods. A common method is the **fan-plus-algorithm** method: the fan is tested as a stand-alone item, typically using *AMCA Standard 300*, and an algorithm is used to predict the effect of the rest of the air-handling unit on the sound as it travels from the fan to the discharge and intake openings or is radiated through a casing with known transmission loss values. Another method is described in *AHRI Standard 260*, in which the entire unit is tested as an assembly, including fans, filters, coils, plenums, casing, etc., and the sound power level at the inlet and discharge openings, as well as the radiated sound power, is measured in a qualified reverberant room. Whenever possible, data obtained by the *AHRI Standard 260* method should be used because it eliminates much of the uncertainty present in the fan-plus-algorithm method. For a detailed description of fan operations, see Chapter 21 in the 2012 *ASHRAE Handbook—HVAC Systems and Equipment*. Different fan types have different noise characteristics and within a fan type, several factors influence noise.

**Table 6 Sound Sources, Transmission Paths, and Recommended Noise Reduction Methods**

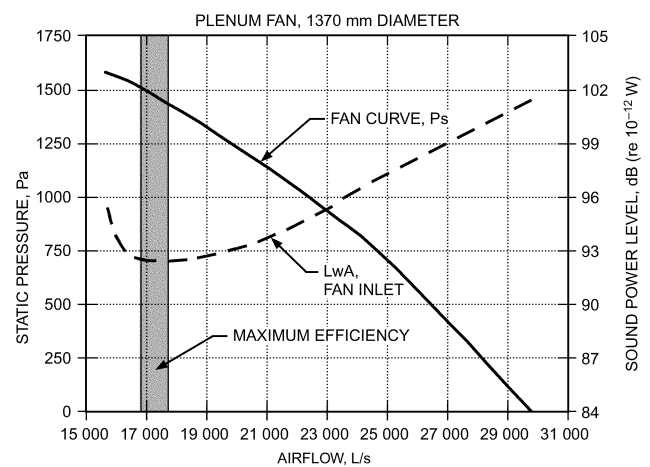
Sound Source		Path No.
Circulating fans; grilles; registers; diffusers; unitary equipment in room		1
Induction coil and fan-powered VAV mixing units		1, 2
Unitary equipment located outside of room served; remotely located air-handling equipment, such as fans, blowers, dampers, duct fittings, and air washers		2, 3
Compressors, pumps, and other reciprocating and rotating equipment (excluding air-handling equipment)		4, 5, 6
Cooling towers; air-cooled condensers		4, 5, 6, 7
Exhaust fans; window air conditioners		7, 8
Sound transmission between rooms		9, 10
No.	Transmission Paths	Noise Reduction Methods
1	Direct sound radiated from sound source to ear Reflected sound from walls, ceiling, and floor	Direct sound can be controlled only by selecting quiet equipment. Reflected sound is controlled by adding sound absorption to room and to equipment location.
2	Air- and structureborne sound radiated from casings and through walls of ducts and plenums is transmitted through walls and ceiling into room	Design duct and fittings for low turbulence; locate high-velocity ducts in noncritical areas; isolate ducts and sound plenums from structure with neoprene or spring hangers.
3	Airborne sound radiated through supply and return air ducts to diffusers in room and then to listener by Path 1	Select fans for minimum sound power; use ducts lined with sound-absorbing material; use duct silencers or sound plenums in supply and return air ducts.
4	Noise transmitted through equipment room walls and floors to adjacent rooms	Locate equipment rooms away from critical areas; use masonry blocks or concrete for mechanical equipment room walls; use floating floors in mechanical rooms.
5	Vibration transmitted via building structure to adjacent walls and ceilings, from which it radiates as noise into room by Path 1	Mount all machines on properly designed vibration isolators; design mechanical equipment room for dynamic loads; balance rotating and reciprocating equipment.
6	Vibration transmission along pipes and duct walls	Isolate pipe and ducts from structure with neoprene or spring hangers; install flexible connectors between pipes, ducts, and vibrating machines.
7	Noise radiated to outdoors enters room windows	Locate equipment away from critical areas; use barriers and covers to interrupt noise paths; select quiet equipment.
8	Indoor noise follows Path 1	Select quiet equipment.
9	Noise transmitted to an air diffuser in a room, into a duct, and out through an air diffuser in another room	Design and install duct attenuation to match transmission loss of wall between rooms; use crosstalk silencers in ductwork.
10	Sound transmission through, over, and around room partition	Extend partition to ceiling slab and tightly seal all around; seal all pipe, conduit, duct, and other partition penetrations.

**Point of Fan Operation.** The point of fan operation has a major effect on acoustical output. Fan selection at the calculated point of maximum efficiency is common practice to ensure minimum power consumption. In general, for a given design, fan sound is at a minimum near the point of maximum efficiency. Noise increases as the operating point shifts to the right, as shown in Figure 8 (higher airflow and lower static pressure). Low-frequency noise can increase substantially at operating points to the left of maximum efficiency (lower airflow and higher static pressure). These operating points should be avoided.

**Blade-Pass Frequency.** The blade-pass frequency is represented by the number of times per second a fan's impeller passes a stationary item:  $f_{bp} = (\text{rpm} \times \text{number of impeller blades})/60$ . All fans generate a tone at this frequency and its multiples (harmonics). Whether this tone is objectionable or barely noticeable depends on the type and design of the fan and the point of operation.

**Housed Centrifugal Fans.** Forward-curved (FC) fans are commonly used in a wide range of standard air-handler products. The blade-pass of FC fans is typically less prominent and is at a higher frequency than other fans. The most distinguishing acoustical concern of FC fans is the prevalent occurrence of low-frequency rumble from airflow turbulence generated at blade tips, which can be exacerbated by nonideal discharge duct conditions (less than five diameters of straight duct). FC fans are commonly thought to have 16, 31.5, and 63 Hz (full octave band) rumble, particularly when operating to the left of the maximum efficiency point.

Backward-inclined (BI) fans and airfoil (AF) fans are generally louder at the blade-pass frequency than a given FC fan selected for the same duty, but are much more energy efficient at higher pressures and airflow. The blade-pass tone generally increases in prominence with increasing fan speed and is typically in a frequency



**Fig. 8 Test Data for Plenum Fan, Comparing Operating Point (Static Pressure and Airflow), A-Weighted Sound Power Level**

range that is difficult to attenuate. Below the blade-pass frequency, these fans generally have lower sound amplitude than FC fans and are often quieter at high frequencies.

Care should be taken with all types of housed fans to allow adequate clearance around the inlets. Also, note that belt guards and inlet screens may decrease airflow and increase sound generation.

**Plenum Fans.** A plenum fan has no housing around the fan impeller and discharges directly into the chamber, pressurizing the plenum, and forcing air through the attached ductwork. Air flows

into the fan impeller through an inlet bell located in the chamber wall. These fans can substantially lower discharge sound power levels if the fan plenum is appropriately sized and acoustically treated with sound-absorptive material.

The plenum discharge should be located away from the fan's air blast, because blowing directly into the duct can aggravate the blade-pass sound. Avoid obstructing the inlet or crowding the coils or filters.

**Vaneaxial Fans.** Generally thought to have the lowest amplitudes of low-frequency sound of any of the fan types, axial fans are often used in applications where the higher-frequency noise can be managed with attenuation devices. In the useful operating range, noise from axial fans is a strong function of the inlet airflow symmetry and blade tip speed.

**Propeller Fans.** Sound from propeller fans generally has a low-frequency-dominated spectrum shape; the blade-pass frequency is typically prominent and occurs in the low-frequency bands because of the small number of blades. Propeller fan blade-pass frequency noise is very sensitive to inlet obstructions. For some propeller fan designs, the shape of the fan venturi (inlet) is also a very important parameter that affects sound levels. In some applications, noise of a propeller fan is described as sounding like a helicopter. Propeller fans are most commonly used on condensers and for power exhausts.

**Minimizing Fan Noise.** To minimize the required air distribution system sound attenuation, proper fan selection and installation are vital. The following factors should be considered:

- Design the air distribution system for minimum airflow resistance. High system resistance requires fans to operate at a higher wattage, which generates higher sound power levels.
- Carefully analyze system pressure losses. Higher-than-expected system resistance may result in higher sound power levels than originally estimated.
- Examine the sound power levels of different fan types and designs. Select a fan (or fans) that generates the lowest sound power levels while meeting other fan selection requirements.
- Many fans generate tones at the blade-pass frequency and its harmonics that may require additional acoustical treatment of the system. Amplitude of these tones can be affected by resonance in the duct system, fan design, and inlet flow distortions caused by poor inlet duct design, or by operation of an inlet volume control damper. When possible, use variable-speed volume control instead of volume control dampers.
- Design duct connections at both fan inlet and outlet for uniform and straight airflow. Avoid unstable, turbulent, and swirling inlet airflow. Deviation from acceptable practice can severely degrade both aerodynamic and acoustic performance of any fan and invalidate manufacturers' ratings or other performance predictions.

### Variable-Air-Volume (VAV) Systems

**General Design Considerations.** As in other aspects of HVAC system design, ducts for VAV systems should be designed for the lowest practical static pressure loss, especially ductwork closest to the fan or air-handling unit (AHU). High airflow velocities and convoluted duct routing with closely spaced fittings can cause turbulent airflow that results in excessive pressure drop and fan instabilities that can cause excessive noise, fan stall, or both.

Many VAV noise complaints have been traced to control problems. Although most problems are associated with improper installation, many are caused by poor design. The designer should specify high-quality fans or air handlers within their optimum ranges, not at the edge of their operation ranges where low system tolerances can lead to inaccurate fan flow capacity control. Also, in-duct static pressure sensors should be placed in duct sections having the lowest possible air turbulence (i.e., at least three equivalent duct diameters from any elbow, takeoff, transition, offset, or damper).

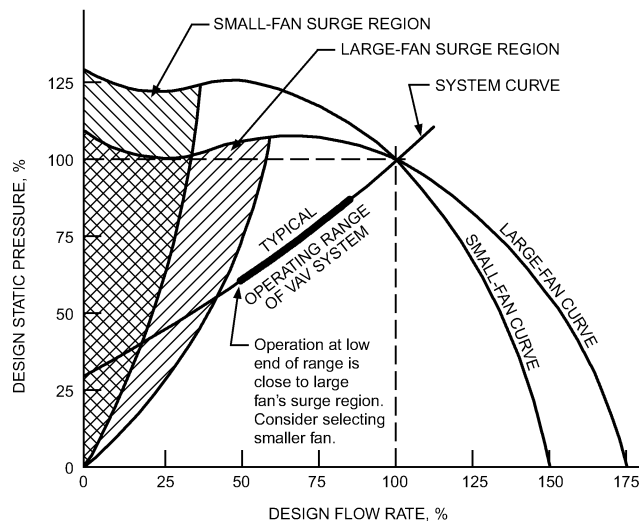


Fig. 9 Basis for Fan Selection in VAV Systems

**Balancing.** VAV noise problems have also been traced to improper air balancing. For example, air balance contractors commonly balance an air distribution system by setting all damper positions without considering the possibility of reducing fan speed. The result is a duct system in which no damper is completely open and the fan delivers air at a higher static pressure than would otherwise be necessary. If the duct system is balanced with at least one balancing damper wide open, fan speed and corresponding fan noise could be reduced. Lower sound levels occur if most balancing dampers are wide open or eliminated. The specified goal should be to balance the system at the lowest static pressure required to operate the box located at the farthest point in the system.

**Fan Selection.** For constant-volume systems, fans should be selected to operate at maximum efficiency at design airflow. However, VAV systems must be selected to operate with efficiency and stability throughout the operating range. For example, a fan selected for peak efficiency at full output may aerodynamically stall at an operating point of 50% of full output, resulting in significantly increased low-frequency noise and unstable airflow. A stalling fan can indicate operation in the **surge region**, an area of operational instability where airflow reverses direction at the fan blade because of insufficient air entering the fan wheel. Similarly, a fan selected to operate most efficiently at the 50% output point may be very inefficient at full output, resulting in substantially increased fan noise at all frequencies. In general, a fan for a VAV system should be selected for peak efficiency at an operating point between 70 and 80% of the maximum required system capacity, which is where the fan will operate most of the time. This usually means selecting a fan that is one size smaller than that required for peak efficiency at 100% of maximum required system capacity (Figure 9). When the smaller fan operates at higher capacities, it produces up to 5 dB more noise. This occasional increase in sound level is usually more tolerable than stall-related sound problems that can occur with a larger fan operating at less than 100% design capacity most of the time.

**Air Modulation Devices.** The control method selected to vary the air capacity of a VAV system is important. Variable-capacity control methods can be divided into three general categories: (1) variable inlet vanes (sometimes called inlet guide vanes) or discharge dampers that yield a new fan system curve at each vane or damper setting, (2) variable-pitch fan blades (usually used on axial fans) that adjust the blade angle for optimum efficiency at varying capacity requirements, and (3) variable-speed motor drives in which motor speed is varied by modulation of the power line frequency or

by mechanical means such as gears or continuous belt adjustment. Inlet vane and discharge damper volume controls can add noise to a fan system at reduced capacities, whereas variable-speed motor drives and variable-pitch fan blade systems are quieter at reduced air output than at full air output.

*Variable-Inlet Vanes and Discharge Dampers.* Variable-inlet vanes vary airflow capacity by changing inlet airflow to a fan wheel. This type of air modulation varies the total air volume and pressure at the fan, but fan speed remains constant. Although fan pressure and air volume reductions at the fan reduce duct system noise by reducing air velocities and pressures in the duct work, there is an associated increase in fan noise caused by airflow turbulence and flow distortions at the inlet vanes. Fan manufacturers' test data show that, on airfoil centrifugal fans, as vanes mounted inside the fan inlet (nested inlet vanes) close, the sound level at the blade-pass frequency of the fan increases by 2 to 8 dB, depending on the percent of total air volume restricted. For externally mounted inlet vanes, the increase is on the order of 2 to 3 dB. The increase for forward-curved fan wheels with inlet vanes is about 1 to 2 dB less than that for airfoil fan wheels. In-line axial fans with inlet vanes generate increased noise levels of 2 to 8 dB in the low-frequency octave bands for a 25 to 50% closed vane position.

Discharge dampers, typically located immediately downstream of the supply air fan, reduce airflow and increase pressure drop across the fan while fan speed remains constant. Because of air turbulence and flow distortions created by the high pressure drop across discharge dampers, there is a high probability of duct rumble near the damper location. If the dampers are throttled to a very low flow, a stall condition can occur at the fan, resulting in an increase in low-frequency noise.

*Variable-Pitch Fans for Capacity Control.* Variable-pitch fan blade controls vary the fan blade angle to reduce airflow. This type of system is predominantly used in axial fans. As air volume and pressure are reduced at the fan, there is a corresponding noise reduction. In the 125 to 4000 Hz octave bands, this reduction usually varies between 2 to 5 dB for a 20% reduction in air volume, and between 8 to 12 dB for a 60% reduction in air volume.

*Variable-Speed-Motor-Controlled Fan.* Three types of electronic variable-speed control units are used with fans: (1) current source inverter, (2) voltage source inverter, and (3) pulse-width modulation (PWM). The current source inverter and third-generation PWM control units are usually the quietest of the three controls. In all three types, matching motors to control units and the quality of the motor windings determine the motor's noise output. The motor typically emits a pure tone with an amplitude that depends on the smoothness of the waveform from the line current. The frequency of the motor tone depends on the motor type, windings, and speed, but is typically at the drive's switching frequency. Some drives allow adjustment to a higher frequency that does not carry as well, but at a cost of lower drive efficiency. Both inverter control units and motors should be enclosed in areas, such as mechanical rooms or electrical rooms, where the noise effect on surrounding rooms is minimal. The primary acoustic advantage of variable-speed fans is reduction of fan speed, which translates into reduced noise; dB reduction is approximately equal to  $50 \times \log$  (higher speed/lower speed). Because this speed reduction generally follows the fan system curve, a fan selected at optimum efficiency initially (lowest noise) does not lose efficiency as the speed is reduced. When using variable-speed controllers,

- Select fan vibration isolators on the basis of the lowest practical speed of the fan. For example, the lowest rotational speed might be 600 rpm for a 1000 rpm fan in a commercial system.
- Select a controller with a feature typically called **critical frequency jump band**. This feature allows a user to program the controller to avoid certain fan or motor rpm settings that might

excite vibration isolation system or building structure resonance frequencies, or correspond to speeds of other fans in the same system.

- Check the intersection of the fan's curve at various speeds against the duct system curve. When selecting a fan controlled by a variable-speed motor controller, keep in mind that the system curve does not go to zero static pressure at no flow. The system curve is asymptotic at the static pressure control set point, typically 250 to 370 Pa. An improperly selected fan may be forced to operate in its stall range at slower fan speeds.

**Terminal Units.** Fans and pressure-reducing valves in VAV units should have manufacturer-published sound data indicating sound power levels that (1) are discharged from the low-pressure end of the unit and (2) radiate from the exterior shell of the unit. These sound power levels vary as a function of valve position and fan point of operation. Sound data for VAV units should be obtained according to the procedures specified by the latest AHRI *Standard* 880. In critical situations, a mock-up test should be conducted of a production terminal box under project conditions and space finishes. The test is required because minor changes in box motor, fan, or valve components can affect the noise generated by such equipment.

If the VAV unit is located in noncritical areas (e.g., above a store-room or corridor), sound radiated from the shell of the unit may be of no concern. If, however, the unit is located above a critical space and separated from the space by a ceiling with little or no sound transmission loss at low frequencies, sound radiated from the shell into the space below may exceed the desired noise criterion. In this case, it may be necessary to relocate the unit to a noncritical area or to enclose it with a high-transmission-loss construction. Room sound levels can be estimated using attenuation factors detailed in AHRI *Standard* 885. In general, fan-powered VAV units should not be placed above or near any room with a required sound criterion rating of less than RC 40(N) (Schaffer 2005). For further information, see the section on Indoor Sound Criteria.

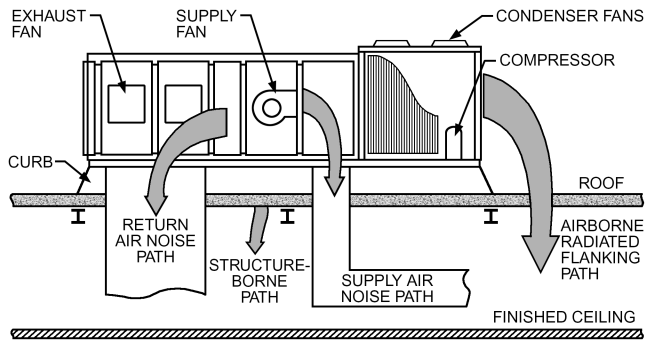
Full shutoff of VAV units can produce excessive duct system pressure at low flow, sometimes causing a fan to go into stall, resulting in accompanying roar, rumble, and surge. Systems providing more than 30% of their air to VAV devices should be provided with a means of static pressure control. Variable-frequency drives are preferred, but in the case of constant-volume air handlers, some means of bypass pressure control should be used to relieve system pressure as VAV devices close down (Schaffer 2005).

### Rooftop-Mounted Air Handlers

Rooftop air handlers can have unique noise control requirements because these units are often integrated into a low-mass roof construction. Large roof openings are often required for supply and return air duct connections. These ducts run directly from noise-generating rooftop air handlers to the building interior. Generally, there is insufficient space or distance between roof-mounted equipment and the closest occupied spaces below the roof to apply standard sound control treatments. Rooftop units should be located above spaces that are not acoustically sensitive and should be placed as far as possible from the nearest occupied space. This measure can reduce the amount of sound control treatment necessary to achieve an acoustically acceptable installation.

The common sound transmission paths associated with rooftop air handlers (Figure 10) are

- Flanking-path-borne sound from condenser fans, or compressors breaking in through low-mass roofs or through windows
- Airborne through bottom of rooftop unit to spaces below
- Structureborne from vibrating equipment in rooftop unit to building structure
- Ductborne through supply air duct from air handler
- Ductborne through return air duct to air handler



**Fig. 10 Sound Paths for Typical Rooftop Installations**

- Duct breakout noise (see the section on Sound Radiation Through Duct Walls)

Flanking-path noise can enter through low-mass roof structures, adjacent walls, and windows. Avoid placing rooftop units on light structure over sensitive spaces or close to higher sidewalls with windows or other lightly constructed building elements. If it is necessary to place the rooftop unit over sensitive spaces or lightly constructed walls, then lagging with additional layers of gypsum board or other similar material may be required in these areas.

Using proper vibration isolation can minimize structureborne sound and vibration from vibrating equipment in a rooftop unit. Special curb mounting bases are available to support and provide vibration isolation for rooftop units. For roofs constructed with open web joists, thin long-span slabs, wooden construction, and any unusually light construction, evaluate all equipment with a mass of more than 130 kg to determine the additional deflection of the structure at mounting points caused by the equipment. Isolator deflection should be a minimum of 10 times the additional static deflection. If the required spring isolator deflection exceeds commercially available products, stiffen the supporting structure or change the equipment location.

Airborne paths are associated with casing-radiated sound that passes through the air handler enclosure and roof structure to the spaces below. Airborne sound can result from air handler noise or from other equipment components in the rooftop unit. Rooftop units should not be placed on open curbs or over a large opening in the roof structure through which both supply and return air ducts pass. Roof penetrations should be limited to two openings sized to accommodate only the supply and return air ducts. These openings should be properly sealed after installation of the ducts. If a large single opening exists under the rooftop unit, it should be structurally, acoustically, and flexibly sealed with one or more layers of gypsum board or other similar material around the supply and return air ducts. Airborne sound transmission to spaces below a rooftop unit can be greatly reduced by placing the rooftop unit on a structural support extending above the roof structure, and running supply and return air ducts horizontally along the roof for several duct diameters before the ducts turn to penetrate the roof. The roof deck/ceiling system below the unit can be constructed to adequately attenuate sound radiated from the bottom of the unit.

Ductborne transmission of sound through the supply air duct consists of two components: sound transmitted from the air handler through the supply air duct system to occupied areas, and sound transmitted via duct breakout through a section or sections of the supply air duct close to the air handler to occupied areas. Sound transmission below 250 Hz through duct breakout is often a major acoustical limitation for many rooftop installations. Excessive low-frequency noise associated with fan noise and air turbulence in the region of the discharge section of the fan (or air handler) and the first duct elbow results in duct rumble, which is difficult to attenuate. This

problem is often worsened by the presence of a high-aspect-ratio duct at the discharge section of the fan (or air handler). Rectangular ducts with duct lagging are often ineffective in reducing duct breakout noise. Using either a single- or dual-wall round duct with a radius elbow coming off the discharge section of the fan can reduce duct breakout. If space does not allow for the use of a single duct, the duct can be split into several parallel round ducts. Another effective method is using an acoustic plenum chamber constructed of a minimum 50 mm thick, dual-wall plenum panel, lined with fiberglass and with a perforated inner liner, at the discharge section of the fan. Either round or rectangular ducts can be taken off the plenum as necessary for the rest of the supply air distribution system. Table 7 shows 12 possible rooftop discharge duct configurations with their associated low-frequency noise reduction potential (Beatty 1987; Harold 1986, 1991).

Ductborne transmission of sound through the return air duct of a rooftop unit is often a problem because there is generally only one short return air duct section between the plenum space above a ceiling and the return air section of the air handler. This does not allow for adequate sound attenuation between the fan inlet and spaces below the air handler. Sound attenuation through the return air duct system can be improved by adding at least one (more if possible) branch division where the return air duct is split into two sections that extend several duct diameters before they terminate into the plenum space above the ceiling. The inside surfaces of all return air ducts should be lined with a minimum of 25 mm thick duct liner. If conditions permit, duct silencers in duct branches or an acoustic plenum chamber at the air-handler inlet section give better sound conditions.

### Aerodynamically Generated Sound in Ducts

Aerodynamic sound is generated when airflow turbulence occurs at duct elements such as duct fittings, dampers, air modulation units, sound attenuators, and room air devices. For details on air modulation units and sound attenuators, see the sections on Variable-Air-Volume (VAV) Systems and Duct Silencers.

Although fans are a major source of sound in HVAC systems, aerodynamically generated sound can often exceed fan sound because of close proximity to the receiver. When making octave-band fan sound calculations using a source-path-receiver analysis, aerodynamically generated sound must be added in the path sound calculations at the location of the element.

**Duct Velocities.** The extent of aerodynamic sound is related to the airflow turbulence and velocity through the duct element. The sound amplitude of aerodynamically generated sound in ducts is proportional to the fifth, sixth, and seventh power of the duct airflow velocity in the vicinity of a duct element (Bullock 1970; Ingard et al. 1968). Therefore, reducing duct airflow velocity significantly reduces flow-generated noise. Tables 8 (Schaffer 2005) and 9 (Egan 1988) give guidelines for recommended airflow velocities in duct sections and duct outlets to avoid problems associated with aerodynamically generated sound in ducts.

**Fixed Duct Fittings.** Fixed duct fittings include elbows, tees, transitions, fixed dampers, and branch takeoffs. In all cases, less generated air turbulence and lower airflow velocities result in less aerodynamic sound. Figures 11 and 12 show typical frequency spectra for specific sizes of elbows and transitions. Data in these figures are based on empirical data obtained from ASHRAE RP-37 (Ingard et al. 1968). Normalized data from ASHRAE RP-37 and others, which can apply to all types of duct fittings and dampers, have been published (Bullock 1970) and presented in ASHRAE RP-265 (Ver 1983a). When multiple duct fittings are installed adjacent to each other, aerodynamic sound can increase significantly because of the added air turbulence and increased velocity pressures. Note that the magnitude of the field-measured static pressure drop across fixed duct fittings does not relate to the aerodynamic

**Table 7 Duct Breakout Insertion Loss—Potential Low-Frequency Improvement over Bare Duct and Elbow**

Discharge Duct Configuration, 3660 mm of Horizontal Supply Duct	Duct Breakout Insertion Loss at Low Frequencies, dB			Side View	End View
	63 Hz	125 Hz	250 Hz		
Rectangular duct: no turning vanes (reference)	0	0	0		0.7 mm THICK 
Rectangular duct: one-dimensional turning vanes	0	1	1		
Rectangular duct: two-dimensional turning vanes	0	1	1		
Rectangular duct: wrapped with foam insulation and two layers of lead	4	3	5	SEE END VIEW	FOAM INSULATION WITH TWO LAYERS LEAD 
Rectangular duct: wrapped with glass fiber and one layer 16 mm gypsum board	4	7	6	SEE END VIEW	GLASS FIBER PRESSED FLAT AGAINST DUCT 
Rectangular duct: wrapped with glass fiber and two layers 16 mm gypsum board	7	9	9	SEE END VIEW	GYPSUM BOARD SCREWED TIGHT 
Rectangular plenum drop (2.5 mm thick): three parallel rectangular supply ducts (0.7 mm thick)	1	2	4	2.5 mm THICK 	0.7 mm THICK 
Rectangular plenum drop (2.5 mm thick): one round supply duct (1.2 mm thick)	8	10	6	2.5 mm THICK 	1.2 mm THICK 
Rectangular plenum drop (2.5 mm thick): three parallel round supply ducts (0.6 mm thick)	11	14	8	2.5 mm THICK 	0.6 mm THICK 
Rectangular (2.0 mm thick) to multiple drop: round mitered elbows with turning vanes, three parallel round supply ducts (0.6 mm thick)	18	12	13	0.6 mm THICK 	2.0 mm THICK 
Rectangular (2.0 mm thick) to multiple drop: round mitered elbows with turning vanes, three parallel round lined double-wall, 560 mm OD supply ducts (0.6 mm thick)	18	13	16	0.6 mm THICK 	2.0 mm THICK 
Round drop: radiused elbow (2.0 mm thick), single 940 mm diameter supply duct	15	17	10	2.0 mm THICK 1.2 mm THICK 	

generated sound. However, total pressure drop across a duct fitting, which includes the velocity pressure change resulting from air turbulence, does affect aerodynamically generated sound.

**Operable Volume Dampers.** Operable damper aerodynamic sound is created because the damper is an obstacle in the airstream, and air turbulence increases as the damper closes. Because total pressure drop across the damper also increases with closure, the aerodynamic sound is related to the total pressure drop. Both single-blade and multiblade dampers, used to balance and control the airflow in a duct system and at room air devices, have similar frequency spectra. Figure 13 shows the frequency spectrum for a 45° damper in a 600 by 600 mm duct (Ingard et al. 1968).

Depending on its location relative to a room air device, a damper can generate sound that is transmitted down the duct to the room air device, or radiate sound through the ceiling space into the occupied space below. When an operable control damper is installed close to an air device to achieve system balance, the acoustic performance of the air outlet must be based not only on the air volume handled, but also on the magnitude of the air turbulence generated at the damper.

The sound level produced by closing the damper is accounted for by adding a correction to the air device sound rating. As the damper is modulated for air balance, this quantity is proportional to the pressure ratio (PR), that is, the throttled total pressure drop across the damper divided by the minimum total pressure drop across the damper. Table 10 provides decibel corrections to determine the effect of damper location on linear diffuser sound ratings.

Volume dampers in sound-critical spaces should always be a minimum of 5 to 10 duct diameters from the air device, with an acoustically lined duct between the damper and air device. Acoustically lined plenums may also be used between the damper and room air device to reduce damper sound. Linear air devices with a round duct connected to an insulated plenum have been successfully used for damper sound control. However, acoustical lining in this type of plenum does not minimize the sound generated by air flowing through a short section of the linear air device. If multiple inlets/outlets are used to spread airflow uniformly over the lined plenum and air device, then the linear slot generates less sound.

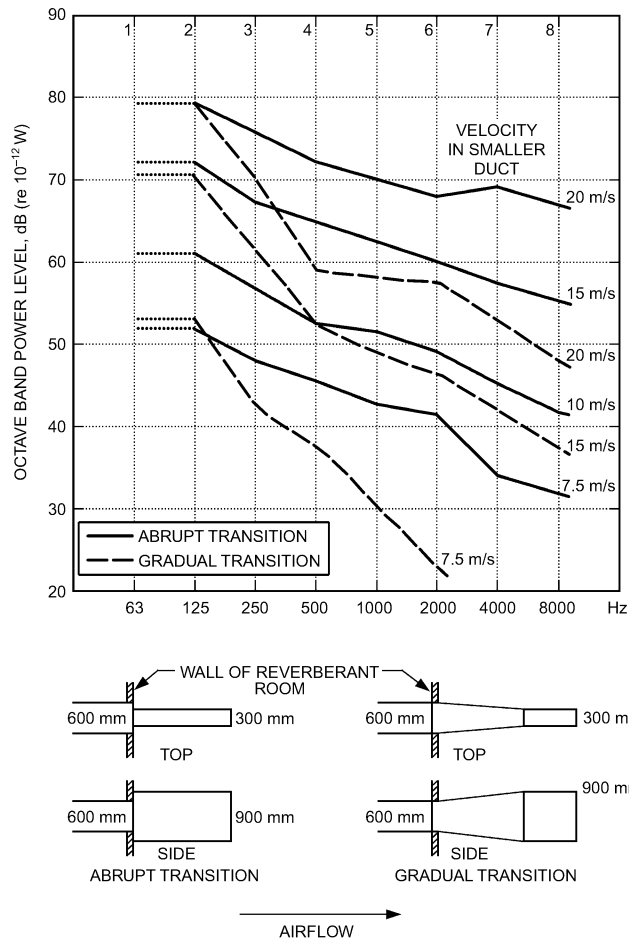
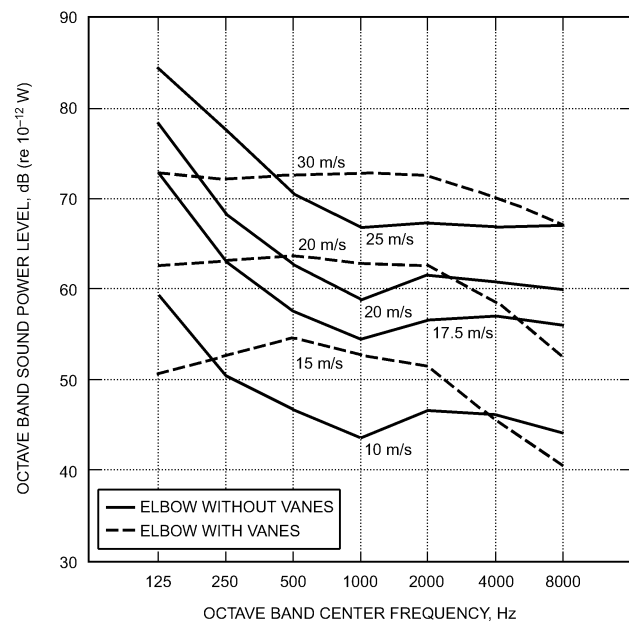


Fig. 11 Velocity-Generated Sound of Duct Transitions



Note: Comparison of octave band sound power levels produced by airflow through 200 x 200 mm rectangular elbow with and without 7 circular arc turning vanes.

Fig. 12 Velocity-Generated Sound of Elbows

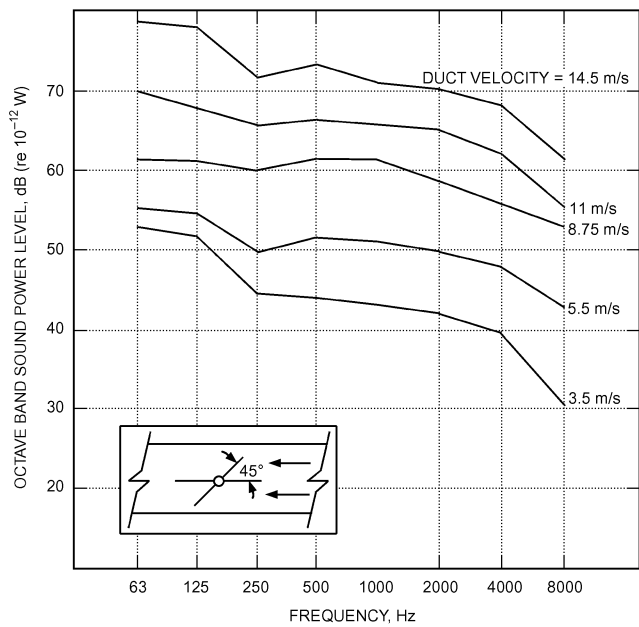


Fig. 13 Velocity-Generated Sound of 600 by 600 mm Volume Damper (Ingard et al. 1968)

Table 8 Maximum Recommended Duct Airflow Velocities to Achieve Specified Acoustic Design Criteria

Main Duct Location	Design RC(N)	Maximum Airflow Velocity, m/s	
		Rectangular Duct	Circular Duct
In shaft or above drywall ceiling	45	17.8	25.4
	35	12.7	17.8
	25	8.6	12.7
Above suspended acoustic ceiling	45	12.7	22.9
	35	8.9	15.2
	25	6.1	10.2
Duct located within occupied space	45	10.2	19.8
	35	7.4	13.2
	25	4.8	8.6

Notes:

1. Branch ducts should have airflow velocities of about 80% of values listed.
2. Velocities in final runouts to outlets should be 50% of values or less.
3. Elbows and other fittings can increase airflow noise substantially, depending on type. Thus, duct airflow velocities should be reduced accordingly.

Proper air balancing of a fan/duct system directly affects aerodynamically generated sound even in a correctly designed and installed duct system. Primary volume dampers in the longest duct from a fan should always be nearly wide open. If the primary damper in the longest duct run is more than 20% closed, the duct system has not been properly air balanced, and the fan may operate at a higher speed than required for the duct system. The result is an increase in air velocities and turbulence throughout the entire duct system, with excessive aerodynamic sound generated at all duct elements.

**Room Air Devices (Grilles, Registers, Diffusers).** Manufacturers' test data should be obtained in accordance with ASHRAE Standard 70 for room air devices such as grilles, registers, diffusers, air-handling light fixtures, and air-handling suspension bars. Devices should be selected to meet the noise criterion required or specified for the room. However, the manufacturer's sound power

**Table 9 Maximum Recommended Air Velocities at Neck of Supply Diffusers or Return Registers to Achieve Specified Acoustical Design Criteria**

Type of Opening	Design RC(N)	“Free” Opening Airflow Velocity, m/s
Supply air outlet	45	3.2
	40	2.8
	35	2.5
	30	2.2
	25	1.8
Return air opening	45	3.8
	40	3.4
	35	3.0
	30	2.5
	25	2.2

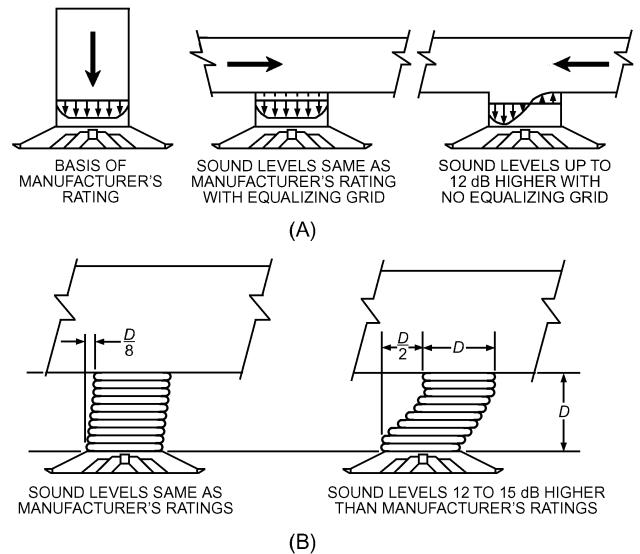
Note: Table intended for use when no sound data are available for selected grilles or diffusers, or no diffuser or grille is used. The number of diffusers or grilles increases sound levels, depending on proximity to receiver. Allowable outlet or opening airflow velocities should be reduced accordingly in these cases.

**Table 10 Decibels to Be Added to Diffuser Sound Rating to Allow for Throttling of Volume Damper**

Location of Volume Damper	Damper Pressure Ratio					
	1.5	2	2.5	3	4	6
	dB to Be Added to Diffuser Sound Rating					
In neck of linear diffuser	5	9	12	15	18	24
In inlet of plenum of linear diffusers	2	3	4	5	6	9
In supply duct at least 1.5 m from inlet plenum of linear diffuser	0	0	0	2	3	5

rating is obtained with a uniform velocity distribution throughout the air device neck or grille collar; this is often not met in practice when a duct turn, sharp transition, or balancing damper immediately precedes the entrance to the diffuser. In these cases, airflow is turbulent and noise generated by the device can be substantially higher than the manufacturer’s published data (by as much as 12 dB). In some cases, placing an equalizer grid in the neck of the air device can greatly reduce this turbulence by helping to provide a uniform velocity gradient in the neck of the device, so the sound power generated in the field is closer to that listed in the manufacturer’s catalog.

At present, air devices are rated by manufacturers in terms of noise criterion (NC) levels, which usually includes a receiver room effect sound correction of 10 dB. The NC ratings may be useful for comparison between different air devices, but are not helpful for source-path-receiver calculations in terms of octave bands. For a complete analysis, the designer should request the component sound power level data in octave bands from the manufacturer. Whether using NC levels or sound power levels, the designer should also correct manufacturer’s data for actual room effect, location of air devices, and number of air devices used in a specific design. The acoustical room effect is the reduction in sound level caused by distance from the sound source (e.g., air outlet); the room volume and amount of acoustical absorption present also affect the value. For example, in a small room with an actual calculated room effect of 6 dB, and given a manufacturer’s room effect correction of 10 dB, the discrepancy (in this case, 4 dB) must be added to the manufacturer’s data. When an air device is located at the intersection of the ceiling and vertical wall, 6 dB should be added, and in the corner of a room, 9 dB should be added to manufacturer’s data. When multiple room air devices are located in a small room or grouped together in a large room, the sound of air devices is additive by up to  $10 \times \log(\text{number of air devices})$ . For more information, see the section on Receiver Room Sound Correction.



**Fig. 14 (A) Proper and Improper Airflow Condition to an Outlet; (B) Effect of Proper and Improper Alignment of Flexible Duct Connector**

A flexible duct connection between a branch air duct and an air device provides a convenient means to align the air device with the ceiling grid. The resulting misalignment in this connection, as shown in Figure 14, can cause as much as 12 to 15 dB higher sound levels in the air device’s aerodynamically generated sound.

**Avoiding Aerodynamically Generated Noise.** Aerodynamic noise in duct systems can be avoided by

- Sizing ductwork and duct elements for low air velocities
- Avoiding abrupt changes in duct cross-sectional area or direction
- Providing smooth airflow at all duct elements, including branches, elbows, tees, transitions, and room air devices
- Providing straight ductwork (preferably 5 to 10 duct diameters) between duct elements
- Air-balancing duct system for lowest reasonable fan speed with dampers generally open
- Locating volume control dampers a minimum of 3 (preferably 5 to 10) duct diameters away from room air devices (Schaffer 2005)

### Water and Air-Cooled Chillers and Air-Cooled Condensers

Chillers and air-cooled condensers have components such as compressors, motors, gears, and fans that can produce significant amounts of both broadband and tonal noise. The broadband noise is typically caused by flows of refrigerant, water, and air, whereas the tonal noise is caused by rotation of compressors, motors, gears, and fans (in fan-cooled equipment). Chiller and condenser noise is significant in the octave bands from 63 to 4000 Hz and depends primarily on the type of compressor used.

**Noise from Compressors and Chillers.** All compressors produce tonal noise to varying degrees. Acoustical differences among compressors relate in large part to their tonal content:

- **Centrifugal compressor** tonal noise comes from rotation of the impeller, refrigerant flow, and gears (if present). Impeller blade-related tonal content is typically not very strong; sound radiates mainly from the compressor and condenser shell. Centrifugal chiller noise can increase at low capacity (10 to 25%) because changing the inlet guide vane to lower the pressure also increases turbulence. The noise gets worse as flow approaches rotating stall. If capacity is reduced using motor speed control, the

resulting compressor sound levels generally decrease with decreasing capacity.

- **Reciprocating compressor** noise has a low-frequency drumming quality, caused by the oscillatory motion of pistons. The tonal content is high, and the sound level decreases very little with decreasing capacity.
- **Scroll compressors** tend to produce relatively weak tones.
- **Screw compressors** (sometimes called helical rotor or rotary compressors) generate very strong tones in the 250 to 2000 Hz octave bands. Rotor-induced tones can be amplified by resonances in the oil separation component or refrigerant lines, and by sound radiation from the condenser shells. Screw compressors have been a source of chiller noise complaints in many installations where their tonal characteristics have not been properly accounted for in the building design process.
- **Absorption chillers** produce relatively little noise themselves, but the flow of steam in associated pumps and valves causes significant high-frequency noise. Noise levels may increase with decreasing capacity as valves close, and combustion air blowers on direct gas-fired units can be noisy.

The noise levels of indoor chillers are used primarily for determining compliance with occupational noise exposure in the workplace [in accordance with U.S. Occupational Safety and Health Administration (OSHA) regulations], and secondarily for determining equipment room transmission loss requirements to ensure that the desired sound levels in adjacent or remote spaces are achieved. The noise levels of outdoor chillers and condensing units are primarily used to determine compliance with local noise ordinances at property lines and to predict sound levels inside adjacent or nearby buildings and residences.

*Indoor Water-Cooled Chillers.* The dominant noise sources in water-cooled chillers are the compressor (most often centrifugal or screw) and condenser. As physical sizes of chillers increase, their radiated sound power levels also increase.

Factory-provided sound data for indoor chillers are typically obtained following AHRI *Standard 575*, which requires measuring the A-weighted and octave band sound pressure level ( $L_p$ ) values at many locations 1 m from the chiller and 1.5 m above the floor. AHRI 575 sound pressure levels are generally available at operating points of 25, 50, and 100% of a chiller's nominal full capacity. The average A-weighted sound pressure levels can be used directly along with exposure times to determine OSHA compliance (OSHA 2011) in the machinery room. An example of the ranges of AHRI *Standard 575* values for atypical centrifugal and screw chiller are shown in Figures 15 and 16, respectively. The sound levels depend on manufacturer design, type and size of compressor, and operating conditions.

AHRI *Standard 575* measurements for factory-provided ratings are often made in very large rooms with an anechoic or minimally reverberant environment rather than that typically found in mechanical equipment rooms. For that reason, assessment of sound pressure levels in situ should typically be adjusted for each chiller installation to account for the mechanical room's size and surface treatment. For a given chiller at a given operating point, a small equipment room (or one with mostly hard surface finishes) has higher  $L_p$  values than one that is large or has sound-absorbing treatments on its ceiling and walls. Figure 17 shows maximum typical adjustment factors that should be added to factory-provided AHRI *Standard 575* values to estimate the  $L_p$  values in specific installations caused by reverberant (reflective) sound effects. The adjustment for each octave band requires knowing the size of an imaginary box that is circumscribed 1 m away from the top and sides of the chiller (the AHRI *Standard 575* measurement surface), the dimensions of the equipment room, and the average sound absorption coefficient of the room surfaces. The adjustment in each octave band depends on the ratio of the

areas of the equipment room and the imaginary box as well as the average sound absorption of the room finishes. Each curve in Figure 17 is for a different value of the average sound absorption, with the higher curves being for lower values.

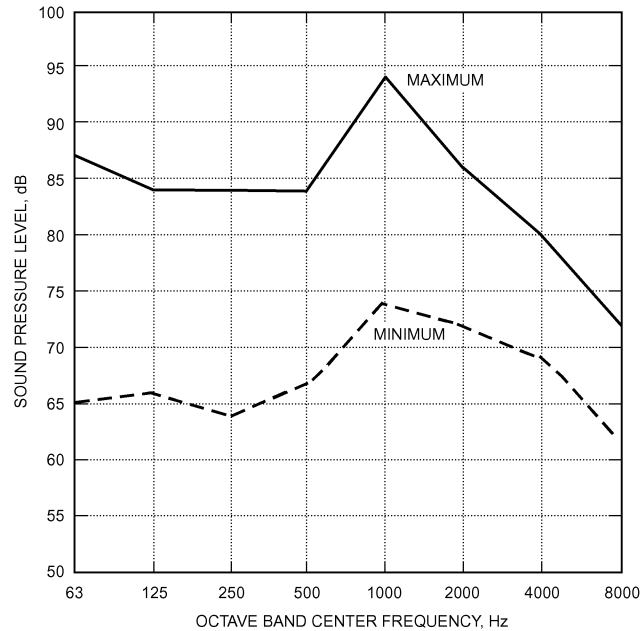


Fig. 15 Typical Minimum and Maximum AHRI *Standard 575*  $L_p$  Values for Centrifugal Chillers (450 to 4500 kW)

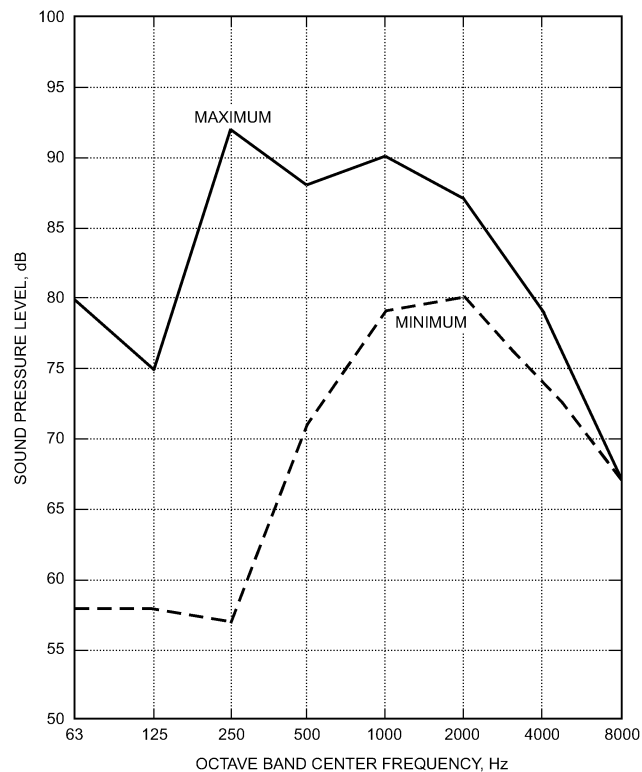
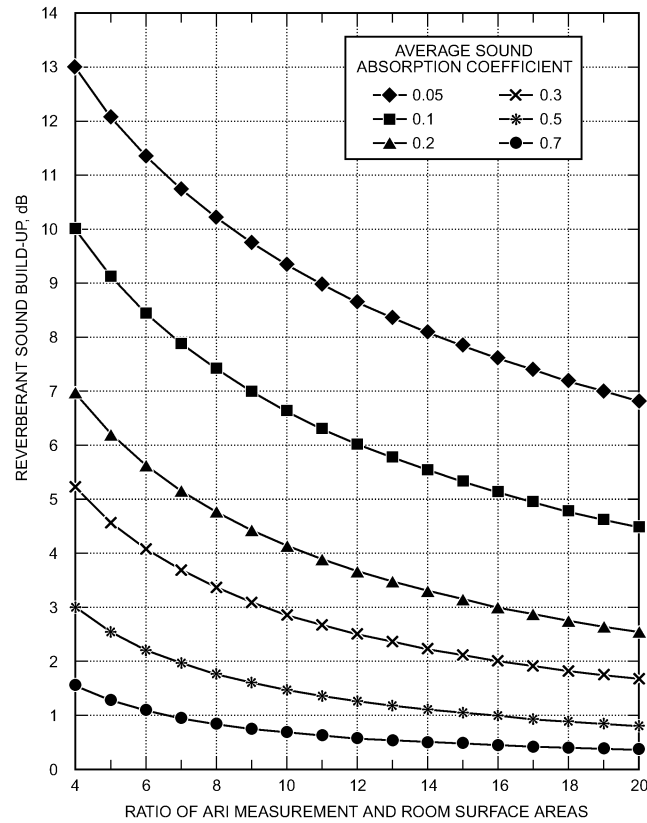


Fig. 16 Typical Minimum and Maximum AHRI *Standard 575*  $L_p$  Values for Screw Chillers (450 to 1400 kW)



**Fig. 17 Estimated Sound Level Build-Up in Mechanical Room for AHRI Standard 575 Chiller Sound Levels**

**Example 2.** Estimate the reverberant  $L_p$  values in a 13.7 by 12.2 by 6.1 m tall mechanical equipment room (MER) that houses a 1260 kW centrifugal chiller. The room has a concrete floor and gypsum board walls and ceiling; all surfaces have an average absorption coefficient of 0.1. The chiller dimensions are 1500 mm wide, 2000 mm tall, and 3000 mm long.

**Solution:**

The AHRI Standard 575 measurement surface area  $S_M$  is determined by adding 1 m to the chiller height and 2 m to both its length and width. The floor area is not included in this calculation. The result is a box 3500 mm wide, 5000 mm long, and 3000 mm tall. The surface area of this box is approximately 68.5 m<sup>2</sup>. The surface area of the equipment room (floor included)  $S_R$  is 650 m<sup>2</sup>. Therefore, the ratio of the areas  $S_R/S_M$  is 650/68.5 = 9.5. Because the average absorption coefficient value for room is 0.1 for all octave bands, see Figure 17 for the adjustment factor and Table 11 for calculations.

The approximate reverberant  $L_p$  values in the last line of Example 2 can be used with sound transmission loss data of the construction to estimate transmitted  $L_p$  values in rooms adjacent to a chiller room.

An alternative approach to this method for estimating  $L_p$  in adjacent rooms is to use an estimate of the sound power levels of the chiller from the factory-provided AHRI Standard 575 values (Stabley 2006) in conjunction with sound transmission loss data. A conversion factor (CF) is determined and used to convert the AHRI Standard 575 sound pressure values to sound power  $L_w$  values. The conversion factor is calculated using

$$CF = 10 \log(S/S_o) \tag{2}$$

where

$$S = \text{area of measurement parallelepiped (excluding the top) used in AHRI Standard 575} \\ = 2(L \times H) + 2(W \times H)$$

**Table 11 Calculations for Reverberation Build-Up**

	Octave Midband Frequency, Hz							
	63	125	250	500	1000	2000	4000	8000
AHRI Standard 575 $L_p$ values	73	74	73	72	74	72	69	63
Adjustment from Figure 17	7	7	7	7	7	7	7	7
Approximate revised $L_p$ in MER	80	81	80	79	81	79	76	70

$L, W,$   
and  $H$  = length, width, and height of measurement parallelepiped, m  
 $S_o = 1 \text{ m}^2$

and

$$L_w = L_p + CF \tag{3}$$

where

$L_w$  = sound power level (A-weighted or octave band)  
 $L_p$  = sound pressure levels per AHRI Standard 575

This approach assumes that the factory-provided data were obtained in a free-field environment.

Indoor chillers are often offered with various types of factory noise-reduction options. These options can include variable-speed drives, or variable-geometry diffusers on centrifugal compressors, to reduce the strength of the noise sources inside the machine. They may also include various external noise-attenuation devices ranging from compressor, refrigerant line, and heat exchanger blankets (typically providing overall noise reduction of 2 to 6 dBA), to complete enclosures with sound-absorbing inner surfaces (which may reduce the overall noise by as much as 18 dBA). The amount of compressor noise reduction achieved by external attenuation approaches is usually limited by structureborne transmission of compressor vibration into the equipment frame and heat exchanger shells, which act as sounding boards. Attenuation options for chiller noise control vary widely, depending on the application and the type of compressor used. Typically, they either reduce the sound radiating from the source (using acoustic enclosures or blankets) or reduce the internal sound-generating mechanisms of the source (using variable-speed drives on compressors and variable-geometry diffusers for centrifugal compressors). The effectiveness of each approach is affected by variables such as the type of compressor and its behavior with load, heat exchanger design, and type of prime mover used.

Field-installed noise-control options include full-sized sheet metal housings with specially treated openings for piping, electrical conduit, and ventilation. This option may require upgraded building construction. For more information, refer to the section on Mechanical Equipment Room Sound Isolation.

**Outdoor Air-Cooled Chillers and Condensers.** Outdoor units often use either reciprocating, scroll, or screw compressors. They are also used as the chiller portion of rooftop packaged units. The dominant noise sources in outdoor air-cooled chillers are the compressors and the condenser fans, which are typically low-cost, high-speed propeller fans. For air-cooled condensing units, propeller fans are the only significant noise source.

Factory sound data for outdoor equipment are obtained in accordance with AHRI Standard 370, which requires determination of the equipment's octave band sound power levels ( $L_w$ ), A-weighted overall sound power level ( $L_{wa}$ ), and tone-adjusted A-weighted overall sound power level ( $L_{wat}$ ). Because AHRI Standard 370 is a sound power measurement technique, it provides certifiable sound data that can be compared across chiller manufacturers with greater certainty than is possible using the sound-pressure-based AHRI Standard 575. An example of the range of AHRI Standard 370  $L_w$  values for outdoor chillers in the 70 to 1300 kW range is given in Figure 18.

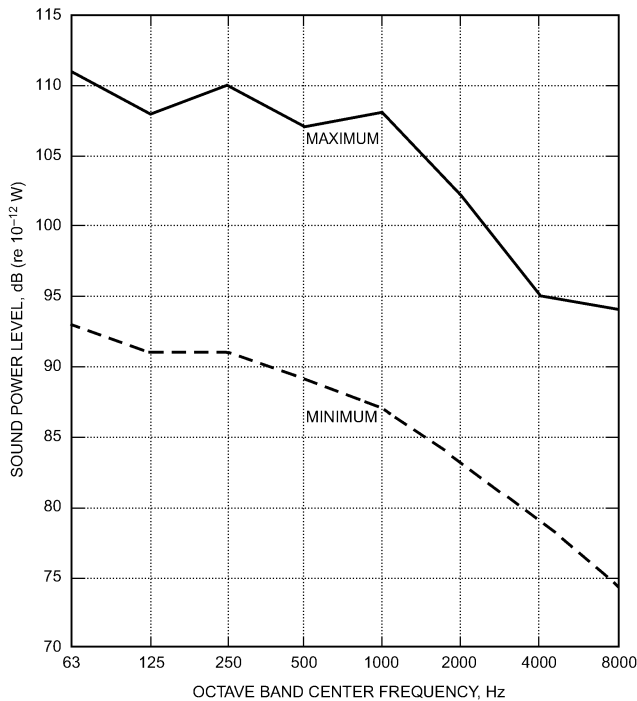


Fig. 18 Typical AHRI 370  $L_w$  Values for Outdoor Chillers (70 to 1300 kW)

Factory-supplied noise reduction options for outdoor equipment include compressor enclosures, component sound blankets, oversized condenser fans, and variable-speed condenser fans. Because air-cooled equipment needs a free flow of cooling air, full enclosures are not feasible. However, strategically placed barriers can help reduce noise propagation on a selective basis. For more information, see the section on Sound Control for Outdoor Equipment.

### Emergency Generators

Emergency or standby generators create very high sound levels and require special consideration, especially if used inside an occupied building. The primary noise sources include the engine casing, radiator, and engine exhaust, and must be considered separately if the generator is installed indoors. Sound power levels for these units depend on the power rating, fuel type, engine speed, exhaust muffler design, and radiator system. Overall sound power levels can be as high as 130 dBA (re  $10^{-12}$  W) for larger (1.5 to 2.0 MW) diesel-powered units with standard mufflers. Noise levels inside generator rooms almost always exceed 100 dBA if the power rating of the unit is greater than 50 kW.

Noise from the generator casing is broadband with a relatively uniform spectrum. Octave band noise data are usually available from the generator manufacturer. Casing noise does not vary much with load. Conversely, exhaust noise typically contains strong tones at the engine shaft's running frequency and at the engine firing rate. Standard engine exhaust mufflers reduce exhaust noise by 20 to 25 dBA (compared to unsilenced exhaust), but even with this noise reduction, strong tones still radiate from the exhaust outlet in most cases. High-performance (critical- and supercritical-grade) mufflers are available but are larger and more expensive than standard units. Exhaust pipes should be routed away from noise-sensitive areas, and the exhaust outlet should be located and oriented to ensure that community noise levels are not excessive. In occupied buildings, the entire exhaust pipe should be suspended from the structure above with spring hangers.

Engine casing noise is best controlled by enclosing the generator in a sound-rated enclosure. The biggest problem with generator room design is finding adequate space for ventilation air. Generators require a substantial volume of air for engine cooling, and controlling engine noise transmission using air intake and exhaust paths can be difficult. In most cases, air intake and exhaust openings require sound attenuators. Because engine radiators usually use propeller fans to move air across the radiator core, the ventilation system cannot always handle the added pressure drop created by sound attenuators. In some cases, auxiliary fans are needed to draw fresh air into the generator room through the intake silencers. Sound attenuators at the discharge opening should be located between the radiator and exhaust louver. A smooth, slowly expanding transition duct is required between the radiator and the discharge louver. Non-symmetrical transitions and transitions with expansion angles greater than  $15^\circ$  usually result in nonuniform airflow through the sound attenuators, causing a higher-than-expected pressure drop and reduced airflow. Unless careful space planning is done early in the design phase, there is often not enough space in the generator room to fit the sound attenuators with a proper transition fitting.

Emergency generator radiator fans usually make as much or more noise than the engine casing. In noise-sensitive installations, consider using a remote radiator. Most manufacturers offer remote radiators as an option, available in a wide variety of designs and noise levels. Lower sound levels with remote radiators are usually achieved by using larger fans running at lower speeds. Using a remote radiator can often save substantial expense in noise-sensitive applications because airflow requirements in the generator room are dramatically reduced.

## 2.4 PATH NOISE ESTIMATION AND CONTROL

### Duct Element Sound Attenuation

A major transmission path of noise from mechanical equipment is through air distribution ductwork. Duct elements and concepts covered in this section include plenums, unlined rectangular ducts, acoustically lined rectangular ducts, unlined round ducts, acoustically lined round ducts, elbows, acoustically lined round radiused elbows, duct silencers, duct branch power division, duct end reflection loss, and terminal volume regulation units. Simplified tabular procedures for obtaining the sound attenuation associated with these elements are presented.

**Plenums.** Plenums are often placed between a fan and main air distribution ducts to smooth turbulent airflow. They are typically lined with acoustically absorbent material to reduce fan and other mechanical noise. Plenums are usually large rectangular enclosures with an inlet and one or more outlets.

Based on experience, ASHRAE-sponsored research (Mouratidis and Becker 2004), and earlier work (Wells 1958), transmission loss associated with a plenum can be expressed using the following considerations:

- Frequency range (based on the cutoff frequency described in the following paragraphs), which is defined as the upper limit for plane wave sound propagation
- In-line inlet and outlet openings
- End-in/end-out versus end-in/side-out orientation (i.e., in-line versus elbow configuration)

At frequencies above the **cutoff frequency**, as defined by the plenum's inlet duct dimensions, the wavelength of sound is small compared to the characteristic dimensions of the plenum. Plane wave propagation in a duct exists at frequencies below the cutoff, creating a need to consider two frequency ranges, where

$$f_{co} = \frac{c}{2a} \quad \text{or} \quad f_{co} = 0.586 \frac{c}{d} \quad (4)$$

where

- $f_{co}$  = cutoff frequency, Hz
- $c$  = speed of sound in air, m/s
- $a$  = larger cross-sectional dimension of rectangular duct, m
- $d$  = diameter of round duct, m

The **cutoff frequency**  $f_{co}$  is the frequency above which plane waves no longer propagate in a duct. At these higher frequencies, waves that propagate in the duct create **cross** or **spinning modes**. The **transmission loss (TL)** in this higher frequency range may be predicted using the following relationship:

$$TL = b \left[ \frac{S_{out} Q}{4\pi r^2} + \frac{S_{out}(1 - \alpha_a)}{S\alpha_a} \right]^n + OAE \quad (5)$$

where

- TL = transmission loss, dB
- $b = 3.505$
- $n = -0.359$
- $S_{out}$  = area of plenum outlet, m<sup>2</sup>
- $S$  = total inside surface area of plenum minus inlet and outlet areas, m<sup>2</sup>
- $r$  = distance between centers of inlet and outlet of plenum, m
- $Q$  = directivity factor; taken as 2 for opening near center of wall, or 4 for opening near corner of plenum
- $\alpha_a$  = average absorption coefficient of plenum lining [see Equation (8)]
- OAE = offset angle effect; additional attenuation found in Tables 14 and 15, which tabulate frequency-dependent sound transmission properties that are manifested when inlet and outlet of plenum are not in a direct line; 90° angle is referred to as elbow effect

The average absorption coefficient  $\alpha_a$  of plenum lining is given by

$$\alpha_a = \frac{S_1 \alpha_1 + S_2 \alpha_2}{S_1 + S_2} \quad (6)$$

where

- $\alpha_1$  = sound absorption coefficient of any bare or unlined inside surfaces of plenum
- $S_1$  = surface area of any bare or unlined inside surfaces of plenum, m<sup>2</sup>
- $\alpha_2$  = sound absorption coefficient of acoustically lined inside surfaces of plenum
- $S_2$  = surface area of acoustically lined inside surfaces of plenum, m<sup>2</sup>

In many situations, inner surfaces of a plenum chamber are lined with a sound-absorbing material. For these situations,  $\alpha_a = \alpha_2$ . Table 12 gives sound absorption coefficients for selected common plenum materials.

*Note:* transmission loss (TL) of a plenum is the difference between the duct sound power level at the outlet and inlet of the plenum, unlike **insertion loss (IL)** ratings for silencers, which represent the difference (at a downstream measurement location) between the duct sound pressure levels with the silencer and with no silencer (replaced with an empty duct). For purposes here, both TL and IL are interpreted as attenuation, or the net reduction in propagating duct sound power.

For frequencies that correspond to plane wave propagation in the duct (below the cutoff frequency), the following relationship applies, with a lower frequency limit of 50 Hz:

$$TL = 10.76A_f S + W_e + OAE \quad (7)$$

where

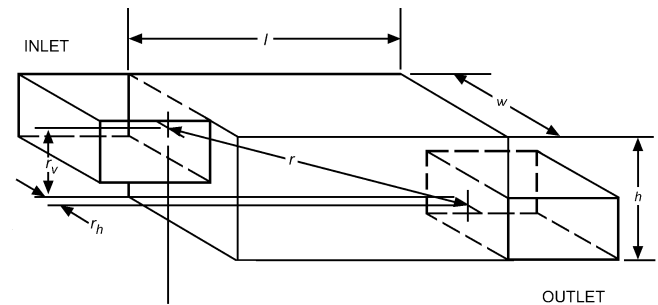
- $A_f$  = surface area coefficient, dB/m<sup>2</sup> (see Table 13 for small and large plenum size ranges)
- $W_e$  = wall effect, dB (see Table 13 for common HVAC plenum wall types)
- OAE = offset angle effect

The maximum TL predicted by Equation (7) should be limited to 20 dB.

**Table 12 Sound Absorption Coefficients  $\alpha$  of Selected Plenum Materials**

	Octave Midband Frequency, Hz						
	63	125	250	500	1000	2000	4000
<b>Non-sound-absorbing material</b>							
Concrete	0.01	0.01	0.01	0.02	0.02	0.02	0.03
Bare sheet metal	0.04	0.04	0.04	0.05	0.05	0.05	0.07
<b>Sound-absorbing material (fiberglass insulation board)</b>							
25 mm, 48 kg/m <sup>3</sup>	0.05	0.11	0.28	0.68	0.90	0.93	0.96
50 mm, 48 kg/m <sup>3</sup>	0.10	0.17	0.86	1.00	1.00	1.00	1.00
75 mm, 48 kg/m <sup>3</sup>	0.30	0.53	1.00	1.00	1.00	1.00	1.00
100 mm, 48 kg/m <sup>3</sup>	0.50	0.84	1.00	1.00	1.00	1.00	0.97

*Note:* 63 Hz values estimated from higher-frequency values.



**Fig. 19 Schematic of End-In/End-Out Plenum**

For an end-in/end-out plenum configuration, where the openings are not in-line, the offset angle  $\theta$  must be considered in the TL calculation. The value of  $\theta$  is obtained from the following relationship:

$$\cos \theta = \frac{l}{r} = \frac{l}{\sqrt{l^2 + r_v^2 + r_h^2}} \quad (8)$$

where (refer to Figure 19)

- $\theta$  = offset angle representing  $r$  to long axis  $l$  of duct
- $l$  = length of plenum, m
- $r_v$  = vertical offset between axes of plenum inlet and outlet, m
- $r_h$  = horizontal offset between axes of plenum inlet and outlet, m

For a given offset angle, apply the applicable effects on TL (decibel addition or subtraction) for angles up to 45° (Table 14).

For an end-in/side-out plenum configuration, where openings are perpendicular to each other, the **elbow effect** must be considered in the TL calculation. For any plenum configuration involving an elbow condition, apply the applicable effects on TL (decibel addition or subtraction) for the two frequency ranges, both above and below the cutoff (Table 15).

For plenum applications within a practical size envelope of 0.5 to 30 m<sup>3</sup> volume or 5 to 60 m<sup>2</sup> surface area, using duct sizes in the range 300 <  $d$  < 1200 mm, this model may be applied with an anticipated standard deviation of  $\pm 3.5$  to 5.0 dB for 50 Hz <  $f \leq f_c$  and  $\pm 1.5$  to 3.0 for  $f_c < f \leq 5000$  Hz. Use caution when applying these prediction methods for plenum configurations where either the width or height dimension is < 1.5 $d$ . In this case, the plenum may not perform as an expansion chamber, thus changing its broadband TL characteristics significantly.

**Example 3.** A small plenum with acoustically lined surfaces is 1.8 m high, 1.2 m wide, and 1.8 m long. The inlet and outlet are each 0.9 m wide by 0.6 m high. The horizontal offset between centers of the plenum inlet

**Table 13 Low-Frequency Characteristics of Plenum TL**

Frequency	Area Coefficient $A_f$ , dB/m <sup>2</sup>		Wall Effect $W_e$ , dB Added					
	For Plenum Volume		25 mm, 40 kg/m <sup>3</sup>	50 mm, 40 kg/m <sup>3</sup>	100 mm, 40 kg/m <sup>3</sup> (Perf. Facing)	200 mm, 40 kg/m <sup>3</sup> (Perf. Facing)	100 mm (Tuned, No Media)	100 mm, 40 kg/m <sup>3</sup> (Double Solid Metal)
	<1.5 m <sup>3</sup>	>1.5 m <sup>3</sup>	(Fabric Facing)	(Fabric Facing)				
50	1.4	0.3	1	1	0	1	0	0
63	1.0	0.3	1	2	3	7	1	3
80	1.1	0.3	2	2	3	9	2	7
100	2.3	0.3	2	2	4	12	1	6
125	2.4	0.4	2	3	6	12	1	4
160	2.0	0.4	3	4	11	11	0	2
200	1.0	0.3	4	10	16	15	4	3
250	2.2	0.4	5	9	13	12	1	1
315	0.7	0.3	6	12	14	14	5	2
400	0.7	0.2	8	13	13	14	7	1
500	1.1	0.2	9	13	12	13	8	0

Source: Mouratidis and Becker (2004).

**Table 14 Offset Angle Effects on TL for End-Outlet Plenum**

Offset Angle Effects on TL for $f \leq f_c$						
Frequency, Hz	Offset Angle $\theta$					
	0	15.0	22.5	30.0	37.5	45.0
50	0	0	0	0	0	0
63	0	0	0	0	0	0
80	0	0	-1	-3	-4	-6
100	0	1	0	-2	-3	-6
125	0	1	0	-2	-4	-6
160	0	0	-1	-2	-3	-4
200	0	0	-1	-2	-3	-5
250	0	1	2	3	5	7
315	0	4	6	8	10	14
400	0	2	4	6	9	13
500	0	1	3	6	10	15
$\geq 630$	N/A	N/A	N/A	N/A	N/A	N/A

Offset Angle Effects on TL for $f > f_c$						
Frequency, Hz	Offset Angle $\theta$					
	0	15.0	22.5	30.0	37.5	45.0
$\leq 160$	N/A	N/A	N/A	N/A	N/A	N/A
200	0	1	4	9	14	20
250	0	2	4	8	13	19
315	0	1	2	3	4	5
400	0	1	2	3	4	6
500	0	0	1	2	4	5
630	0	1	2	3	5	7
800	0	1	2	2	3	3
1000	0	1	2	4	6	9
1250	0	0	2	4	6	9
1600	0	0	1	1	2	3
2000	0	1	2	4	7	10
2500	0	1	2	3	5	8
3150	0	0	2	4	6	9
4000	0	0	2	5	8	12
5000	0	0	3	6	10	15

N/A = not applicable

and outlet is 0.3 m. The vertical offset is 1.2 m. The inside of the plenum is completely lined with 25 mm thick fibreglass insulation board, with sound absorption values as shown in Table 8. Determine the transmission loss TL associated with this plenum.

**Solution:**

The areas of the inlet section, outlet section, and overall surfaces are

**Table 15 Elbow Effect, dB**

Frequency, Hz	$> f_c$	$\leq f_c$
50	0	2
63	0	3
80	0	6
100	0	5
125	0	3
160	0	0
200	3	-2
250	6	-3
315	3	-1
400	3	0
500	2	0
630	3	0
800	3	0
1000	2	0
1250	2	0
1600	2	0
2000	2	0
2500	2	0
3150	2	0
4000	2	0
5000	1	0

N/A = not applicable

$$S_{in} = 0.9 \times 0.6 = 0.54 \text{ m}^2$$

$$S_{out} = 0.9 \times 0.6 = 0.54 \text{ m}^2$$

$$S = \text{Total surface area (all walls with lining)} \\ = 2(1.2 \times 1.8) + 2(1.2 \times 1.8) + 2(1.8 \times 1.8) - 0.54 - 0.54 \\ = 14.04 \text{ m}^2$$

with  $l = 1.8$  m,  $r_v = 1.2$  m, and  $r_h = 0.3$  m,

$$r = (1.8^2 + 1.2^2 + 0.3^2)^{1/2} = 2.184 \text{ m}$$

$$\theta = \cos^{-1}(1.8/2.184) = 35^\circ$$

The cutoff frequency  $f_c$  is

$$f_c = 343/(2 \times 0.9) = 190 \text{ Hz}$$

where 343 m/s is the approximate speed of sound in standard air.

**Frequency Range #1** (1/3-octave TL in 50 Hz  $\leq f \leq f_c$  range)

$$TL = 10.76 \times A_f \times S + W_e + \text{OAE} \tag{9}$$

(Consult Table 13 for  $A_f$  and  $W_e$  and Table 14 for offset angle effect.)

Frequency Range #2 (1/3-octave TL in  $f_c < f \leq 5000$  Hz range)

$$TL = b \left[ \frac{S_{out} Q}{4\pi r^2} \frac{S_{out}(1 - \alpha_a)}{S\alpha_a} \right]^n + OAE \quad (10)$$

where

$b = 3.505$

$n = -0.359$

$Q = 4$  (directivity factor for inlet opening close to adjacent wall or bihedral corner of plenum)

$\alpha_a = 1/3$ -octave average absorption values for 25 mm fiberglass lining (see Table 12)

OAE = see Table 14

Note: for angles between tabulated values in Table 14, use linear interpolation.

The results are tabulated as follows:

	(1)	(2)	(3)	(4)	(5)	(6)	
1/3-Octave TL in	1/3-Octave Freq., Hz	$A_f$ , dB/m <sup>2</sup>	$W_e$ , dB	OAE, dB	TL for Frequency Range 1, <sup>a</sup> dB	TL for Frequency Range 2, <sup>b</sup> dB	Net TL, <sup>c</sup> dB
$50 \leq f \leq 189$ Hz	50	0.3	1	0	6		6
	63	0.3	1	0	6		6
	80	0.3	2	-4	3		3
	100	0.3	2	-3	4		4
	125	0.4	2	-4	4		4
	160	0.4	3	-3	6		6
$f_c < f \leq 5000$ Hz	200			12		20	20
	250			11		19	19
	315			4		13	13
	400			4		14	14
	500			3		13	13
	630			4		14	14
	800			3		14	14
	1000			5		16	16
	1300			5		16	16
	1600			2		13	13
	2000			6		17	17
	2500			4		15	15
	3200			5		16	16
4000			7		18	18	
5000			8		19	19	

OAE = offset angle effect

<sup>a</sup>Column 1  $\times$  S + column 2 + column 3

<sup>b</sup>Includes OAE value from column 3 per calculation from Equation (10).

<sup>c</sup>From column 4 or 5, depending on appropriate frequency range.

**Unlined Rectangular Sheet Metal Ducts.** Straight, unlined rectangular sheet metal ducts provide a fairly significant amount of low-frequency sound attenuation. Table 16 shows the results of selected unlined rectangular sheet metal ducts (Cummings 1983; Reynolds and Bledsoe 1989a; Ver 1978; Woods Fan Division 1973). Attenuation values in Table 16 apply only to rectangular sheet metal ducts with the lightest gages allowed by Sheet Metal and Air Conditioning Contractors' National Association, Inc. (SMACNA) HVAC duct construction standards. Attenuation for lengths greater than 3 m is not well documented.

Sound energy attenuated at low frequencies in rectangular ducts may manifest itself as breakout noise along the duct. Low-frequency breakout noise should therefore be checked. For additional information on breakout noise, see the section on Sound Radiation Through Duct Walls.

**Acoustically Lined Rectangular Sheet Metal Ducts.** Internal duct lining for rectangular sheet metal ducts can be used to provide both thermal insulation and sound attenuation. The thickness of

Table 16 Sound Attenuation in Unlined Rectangular Sheet Metal Ducts

Duct Size, mm	$P/A$ , 1/mm	Attenuation, dB/m			
		Octave Midband Frequency, Hz			
		63	125	250	>250
150 $\times$ 150	0.26	0.98	0.66	0.33	0.33
305 $\times$ 305	0.13	1.15	0.66	0.33	0.20
305 $\times$ 610	0.10	1.31	0.66	0.33	0.16
610 $\times$ 610	0.07	0.82	0.66	0.33	0.10
1220 $\times$ 1220	0.03	0.49	0.33	0.23	0.07
1830 $\times$ 1830	0.02	0.33	0.33	0.16	0.07

duct linings for thermal insulation usually varies from 15 to 50 mm; density of fiberglass lining usually varies between 24 and 48 kg/m<sup>3</sup>, but may be as low as 12 kg/m<sup>3</sup>. For fiberglass duct lining to attenuate fan sound effectively, it should have a minimum thickness of 25 mm. Tables 17 and 18 give attenuation values of selected rectangular sheet metal ducts for 25 and 50 mm duct lining, respectively (Kuntz 1986; Kuntz and Hoover 1987; Machen and Haines 1983; Reynolds and Bledsoe 1989a). Note that attenuation values shown in these tables are based on laboratory tests using 3 m lengths of duct; for designs incorporating other distances, actual values will be different. The total attenuated noise will never be below the generated noise level in the duct.

**Insertion loss** values in Tables 17 and 18 are the difference in the sound pressure level measured in a reverberation room with sound propagating through an unlined section of rectangular duct minus the corresponding sound pressure level measured when the unlined section of rectangular duct is replaced with a similar section of acoustically lined rectangular duct. The net result is the attenuation resulting from adding duct liner to a sheet metal duct.

Insertion loss and attenuation values discussed in this section apply only to rectangular sheet metal ducts made with the lightest gages allowed by SMACNA HVAC duct construction standards. Attenuation for lengths greater than 3 m is not well documented.

**Unlined Round Sheet Metal Ducts.** As with unlined rectangular ducts, unlined round ducts provide some natural sound attenuation that should be taken into account when designing a duct system. Compared to rectangular ducts, round ducts are much more rigid and thus do not absorb as much sound energy. Because of this, round ducts only provide about one-tenth the sound attenuation at low frequencies as rectangular ducts. However, breakout from round ducts is significantly less than that from other shapes. Table 19 lists sound attenuation values for unlined round ducts (Kuntz and Hoover 1987; Woods Fan Division 1973).

**Acoustically Lined Round Sheet Metal Ducts.** The literature provides very little information on insertion loss for acoustically lined round ducts; usually only manufacturers' product data are available. Tables 20 and 21 give insertion loss values for dual-wall round sheet metal ducts with 25 and 50 mm acoustical lining, respectively (Reynolds and Bledsoe 1989b). The acoustical lining is a 12 kg/m<sup>3</sup> density fiberglass blanket, which is covered by an internal liner of perforated galvanized sheet metal with an open area of 25%. The data in Tables 20 and 21 were collected from 6 m duct sections. Because there are many options available for round ducts, attenuation may significantly vary from the data provided in the tables.

**Rectangular Sheet Metal Duct Elbows.** Table 22 displays insertion loss values for unlined and lined square elbows without turning vanes (Beranek 1960). For lined square elbows, duct lining must extend at least two duct widths  $w$  beyond the elbow. Table 22 applies only where the duct is lined before and after the elbow. Table 23 gives insertion loss values for unlined radiused elbows. Table 24 gives insertion loss values for unlined and lined square elbows with turning vanes. The quantity  $f_w$  in Tables 22 to 24 is the midfrequency of the

**Table 17 Insertion Loss for Rectangular Sheet Metal Ducts with 25 mm Fiberglass Lining**

Dimensions, mm	Insertion Loss, dB/m					
	Octave Band Center Frequency, Hz					
	125	250	500	1000	2000	4000
150 × 150	2.0	4.9	8.9	19.0	24.3	14.1
150 × 250	1.6	3.9	7.9	16.7	20.0	12.1
150 × 300	1.6	3.9	7.5	16.4	19.0	11.8
150 × 460	1.6	3.3	7.2	15.4	17.1	10.8
200 × 200	1.6	3.9	7.5	16.4	19.0	11.8
200 × 300	1.3	3.3	6.9	14.8	16.1	10.5
200 × 460	1.3	3.0	6.6	14.1	14.8	9.8
200 × 610	1.3	2.6	6.2	13.1	13.5	9.2
250 × 250	1.3	3.3	6.9	14.4	15.4	10.2
250 × 410	1.3	2.6	6.2	13.1	13.1	8.9
250 × 510	1.0	2.6	5.9	12.5	12.1	8.5
250 × 760	1.0	2.3	5.6	11.8	10.8	7.9
300 × 300	1.3	2.6	6.2	13.1	13.5	9.2
300 × 460	1.0	2.3	5.6	12.1	11.5	8.2
300 × 610	1.0	2.0	5.6	11.5	10.5	7.5
300 × 910	1.0	2.0	5.2	10.8	9.5	7.2
380 × 380	1.0	2.3	5.6	11.8	10.8	7.9
380 × 560	1.0	2.0	5.2	10.8	9.5	7.2
380 × 760	1.0	1.6	4.9	10.2	8.5	6.6
380 × 1140	0.7	1.6	4.6	9.5	7.9	6.2
460 × 460	1.0	2.0	5.2	10.8	9.5	7.2
460 × 710	0.7	1.6	4.6	9.8	7.9	6.2
460 × 910	0.7	1.6	4.6	9.2	7.2	5.9
460 × 1370	0.7	1.3	4.3	8.9	6.6	5.6
610 × 610	0.7	1.6	4.6	9.2	7.2	5.9
610 × 910	0.7	1.3	3.9	8.5	6.2	5.2
610 × 1220	0.7	1.3	3.9	7.9	5.6	4.9
610 × 1830	0.7	1.0	3.6	7.5	5.2	4.6
760 × 760	0.7	1.3	3.9	8.2	5.9	5.2
760 × 1140	0.7	1.0	3.6	7.5	5.2	4.6
760 × 1520	0.7	1.0	3.6	7.2	4.6	4.3
760 × 2290	0.3	1.0	3.3	6.9	4.3	3.9
910 × 910	0.7	1.0	3.6	7.5	5.2	4.6
910 × 1370	0.3	1.0	3.3	6.9	4.3	3.9
910 × 1830	0.3	1.0	3.3	6.6	3.9	3.9
910 × 1830	0.3	0.7	3.0	6.2	3.6	3.6
1070 × 1070	0.7	1.0	3.3	6.9	4.6	4.3
1070 × 1630	0.3	1.0	3.0	6.2	3.9	3.6
1070 × 2130	0.3	0.7	3.0	5.9	3.6	3.6
1070 × 3200	0.3	0.7	3.0	5.6	3.3	3.3
1220 × 1220	0.3	1.0	3.3	6.6	3.9	3.9
1220 × 1830	0.3	0.7	3.0	5.9	3.3	3.3
1020 × 2440	0.3	0.7	2.6	5.6	3.3	3.3
1020 × 3660	0.3	0.7	2.6	5.2	3.0	3.0

octave band times the width of the elbow (Figure 20) (Beranek 1960; Ver 1983b).

**Nonmetallic Insulated Flexible Ducts.** Nonmetallic insulated flexible ducts can significantly reduce airborne noise. Insertion loss values for specified duct diameters and lengths are given in Table 25 and in Appendix D of ARI Standard 885. Recommended duct lengths are normally 0.9 to 1.8 m. Take care to keep flexible ducts straight; bends should have as long a radius as possible. Although an abrupt bend may provide some additional insertion loss, the noise associated with airflow in the bend may be unacceptably high. Because of potentially high breakout sound levels associated with

**Table 18 Insertion Loss for Rectangular Sheet Metal Ducts with 50 mm Fiberglass Lining**

Dimensions, mm	Insertion Loss, dB/m					
	Octave Band Center Frequency, Hz					
	125	250	500	1000	2000	4000
150 × 150	2.6	9.5	16.1	23.6	24.3	14.1
150 × 250	2.3	7.9	14.4	21.0	20.0	12.1
150 × 300	2.0	7.5	13.8	20.3	19.0	11.8
150 × 460	2.0	6.9	13.1	19.0	17.1	10.8
200 × 200	2.0	7.5	13.8	20.3	19.0	11.8
200 × 300	2.0	6.2	12.8	18.4	16.1	10.5
200 × 460	1.6	5.9	12.1	17.7	14.8	9.8
200 × 610	1.6	5.2	11.5	16.4	13.5	9.2
250 × 250	2.0	6.2	12.5	18.0	15.4	10.2
250 × 410	1.6	5.2	11.2	16.4	13.1	8.9
250 × 510	1.3	4.9	10.8	15.7	12.1	8.5
250 × 760	1.3	4.3	10.2	14.8	10.8	7.9
300 × 300	1.6	5.2	11.5	16.4	13.5	9.2
300 × 460	1.3	4.6	10.5	15.1	11.5	8.2
300 × 610	1.3	4.3	9.8	14.1	10.5	7.5
300 × 910	1.3	3.9	9.5	13.5	9.5	7.2
380 × 380	1.3	4.3	10.2	14.8	10.8	7.9
380 × 560	1.3	3.9	9.5	13.5	9.5	7.2
380 × 760	1.0	3.6	8.9	12.8	8.5	6.6
380 × 1140	1.0	3.3	8.5	11.8	7.9	6.2
460 × 460	1.3	3.9	9.5	13.5	9.5	7.2
460 × 710	1.0	3.3	8.5	12.1	7.9	6.2
460 × 910	1.0	3.0	8.2	11.5	7.2	5.9
460 × 1370	1.0	2.6	7.5	10.8	6.6	5.6
610 × 610	1.0	3.0	8.2	11.5	7.2	5.9
610 × 910	1.0	2.6	7.5	10.5	6.2	5.2
610 × 1220	0.7	2.3	7.2	9.8	5.6	4.9
610 × 1830	0.7	2.3	6.6	9.5	5.2	4.6
760 × 760	0.7	2.6	7.2	10.2	5.9	5.2
760 × 1140	0.7	2.3	6.6	9.5	5.2	4.6
760 × 1520	0.7	2.0	6.2	8.9	4.6	4.3
760 × 2290	0.7	1.6	5.9	8.5	4.3	3.9
910 × 910	0.7	2.3	6.6	9.5	5.2	4.6
910 × 1370	0.7	2.0	6.2	8.5	4.3	3.9
910 × 1830	0.7	1.6	5.9	8.2	3.9	3.9
910 × 1830	0.7	1.6	5.6	7.5	3.6	3.6
1070 × 1070	0.7	2.0	6.2	8.5	4.6	4.3
1070 × 1630	0.7	1.6	5.6	7.9	3.9	3.6
1070 × 2130	0.7	1.6	5.2	7.5	3.6	3.6
1070 × 3200	0.3	1.3	5.2	7.2	3.3	3.3
1220 × 1220	0.7	1.6	5.9	8.2	3.9	3.9
1220 × 1830	0.7	1.3	5.2	7.5	3.3	3.3
1020 × 2440	0.3	1.3	4.9	6.9	3.3	3.3
1020 × 3660	0.3	1.3	4.9	6.6	3.0	3.0

**Table 19 Sound Attenuation in Straight Round Ducts**

Diameter, mm	Attenuation, dB/m						
	Octave Band Center Frequency, Hz						
	63	125	250	500	1000	2000	4000
$D \leq 180$	0.10	0.10	0.16	0.16	0.33	0.33	0.33
$180 < D \leq 380$	0.10	0.10	0.10	0.16	0.23	0.23	0.23
$380 < D \leq 760$	0.07	0.07	0.07	0.10	0.16	0.16	0.16
$760 < D \leq 1520$	0.03	0.03	0.03	0.07	0.07	0.07	0.07

flexible ducts, take care when using flexible ducts above sound-sensitive spaces.

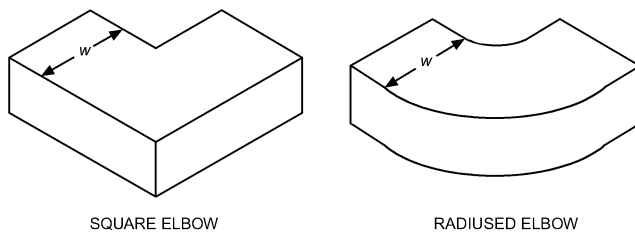
**Duct Branch Sound Power Division.** When sound traveling in a duct encounters a junction, the sound power contained in the incident sound waves in the main feeder duct is distributed between the branches associated with the junction (Ver 1982, 1983b). This

**Table 20 Insertion Loss for Acoustically Lined Round Ducts with 25 mm Lining**

Diameter, mm	Insertion Loss, dB/m Octave Band Center Frequency, Hz							
	63	125	250	500	1000	2000	4000	8000
150	1.25	1.94	3.05	5.02	7.12	7.58	6.69	4.13
205	1.05	1.77	2.92	4.92	7.19	7.12	6.00	3.87
255	0.89	1.64	2.79	4.86	7.22	6.69	5.38	3.67
305	0.75	1.51	2.66	4.76	7.15	6.27	4.86	3.44
355	0.62	1.38	2.53	4.69	7.02	5.87	4.40	3.28
405	0.52	1.25	2.40	4.59	6.82	5.48	3.97	3.12
460	0.43	1.15	2.26	4.49	6.59	5.12	3.61	2.95
510	0.36	1.02	2.13	4.40	6.30	4.76	3.28	2.85
560	0.26	0.92	2.00	4.30	5.97	4.40	3.02	2.72
610	0.23	0.82	1.87	4.20	5.61	4.07	2.79	2.62
660	0.16	0.72	1.74	4.07	5.22	3.74	2.59	2.53
710	0.10	0.62	1.61	3.94	4.79	3.41	2.43	2.43
760	0.07	0.52	1.48	3.81	4.36	3.12	2.26	2.33
815	0.03	0.46	1.38	3.67	3.94	2.85	2.17	2.26
865	0	0.36	1.25	3.51	3.51	2.59	2.07	2.17
915	0	0.26	1.15	3.35	3.05	2.33	1.97	2.10
965	0	0.20	1.02	3.15	2.62	2.10	1.90	2.00
1015	0	0.10	0.92	2.99	2.23	1.87	1.80	1.90
1070	0	0.03	0.82	2.76	1.84	1.64	1.74	1.80
1120	0	0	0.75	2.56	1.48	1.44	1.67	1.71
1170	0	0	0.66	2.33	1.15	1.28	1.57	1.57
1220	0	0	0.59	2.07	0.85	1.12	1.48	1.44
1270	0	0	0.49	1.80	0.62	0.95	1.35	1.31
1320	0	0	0.46	1.51	0.43	0.82	1.21	1.12
1370	0	0	0.39	1.21	0.30	0.72	1.02	0.95
1420	0	0	0.33	0.92	0.26	0.59	0.82	0.72
1475	0	0	0.30	0.56	0.26	0.52	0.59	0.49
1525	0	0	0.26	0.20	0.33	0.46	0.30	0.23

**Table 21 Insertion Loss for Acoustically Lined Round Ducts with 50 mm Lining**

Diameter, mm	Insertion Loss, dB/m Octave Band Center Frequency, Hz							
	63	125	250	500	1000	2000	4000	8000
150	1.84	2.62	4.49	7.38	7.12	7.58	6.69	4.13
205	1.67	2.46	4.36	7.32	7.19	7.12	6.00	3.87
255	1.51	2.33	4.23	7.22	7.22	6.69	5.38	3.67
305	1.38	2.20	4.10	7.15	7.15	6.27	4.86	3.44
355	1.25	2.07	3.97	7.05	7.02	5.87	4.40	3.28
405	1.15	1.94	3.84	6.96	6.82	5.48	3.97	3.12
460	1.05	1.84	3.71	6.89	6.59	5.12	3.61	2.95
510	0.95	1.71	3.58	6.79	6.30	4.76	3.28	2.85
560	0.89	1.61	3.44	6.66	5.97	4.40	3.02	2.72
610	0.82	1.51	3.31	6.56	5.61	4.07	2.79	2.62
660	0.79	1.41	3.18	6.43	5.22	3.74	2.59	2.53
710	0.72	1.31	3.05	6.33	4.79	3.41	2.43	2.43
760	0.69	1.21	2.95	6.17	4.36	3.12	2.26	2.33
815	0.66	1.12	2.82	6.04	3.94	2.85	2.17	2.26
865	0.62	1.05	2.69	5.87	3.51	2.59	2.07	2.17
915	0.59	0.95	2.59	5.71	3.05	2.33	1.97	2.10
965	0.56	0.89	2.49	5.54	2.62	2.10	1.90	2.00
1015	0.52	0.79	2.40	5.35	2.23	1.87	1.80	1.90
1070	0.49	0.72	2.30	5.15	1.84	1.64	1.74	1.80
1120	0.43	0.66	2.20	4.92	1.48	1.44	1.67	1.71
1170	0.39	0.56	2.10	4.69	1.15	1.28	1.57	1.57
1220	0.36	0.49	2.03	4.46	0.85	1.12	1.48	1.44
1270	0.30	0.39	1.97	4.20	0.62	0.95	1.35	1.31
1320	0.23	0.33	1.90	3.90	0.43	0.82	1.21	1.12
1370	0.16	0.26	1.84	3.61	0.30	0.72	1.02	0.95
1420	0.07	0.16	1.80	3.28	0.26	0.59	0.82	0.72
1475	0	0.10	1.74	2.95	0.26	0.52	0.59	0.49
1525	0	0	1.74	2.59	0.33	0.46	0.30	0.23



**Fig. 20 Rectangular Duct Elbows**

division of sound power is called branch sound power division. The corresponding attenuation of sound power transmitted down each branch of the junction is comprised of two components. The first is associated with reflection of the incident sound wave if the sum of the cross-sectional areas of individual branches  $\sum S_{Bi}$  differs from the cross-sectional area of the main feeder duct. The second and more dominant component is associated with energy division according to the ratio of the cross-sectional area of an individual branch  $S_{Bi}$  divided by  $\sum S_{Bi}$ . Values for the attenuation of sound power  $\Delta L_{Bi}$  are given in Table 26.

**Duct Silencers.** Silencers, sometimes called sound attenuators, sound traps, or mufflers, are designed to reduce the noise transmitted from a source to a receiver. For HVAC applications, the most common silencers are duct silencers, installed on the intake and/or discharge side of a fan or air handler. Also, they may be used on the receiver side of other noise generators such as terminal boxes, valves, dampers, etc.

Duct silencers are available in varying shapes and sizes to fit project ductwork. Generally, a duct silencer's outer appearance is

**Table 22 Insertion Loss of Unlined and Lined Square Elbows Without Turning Vanes**

	Insertion Loss, dB	
	Unlined Elbows	Lined Elbows
$fw < 48$	0	0
$48 \leq fw < 96$	1	1
$96 \leq fw < 190$	5	6
$190 \leq fw < 380$	8	11
$380 \leq fw < 760$	4	10
$fw > 760$	3	10

Note:  $f$  = center frequency, kHz, and  $w$  = width, mm

**Table 23 Insertion Loss of Radiused Elbows**

	Insertion Loss, dB
$fw < 48$	0
$48 \leq fw < 96$	1
$96 \leq fw < 190$	2
$fw > 190$	3

Note:  $f$  = center frequency, kHz, and  $w$  = width, mm

similar to a piece of ductwork. It consists of a sheet metal casing with length commonly ranging from 0.9 to 3 m. Common shapes include rectangular, round, elbow, tee, and transitional. Figure 21 shows some duct silencer configurations.

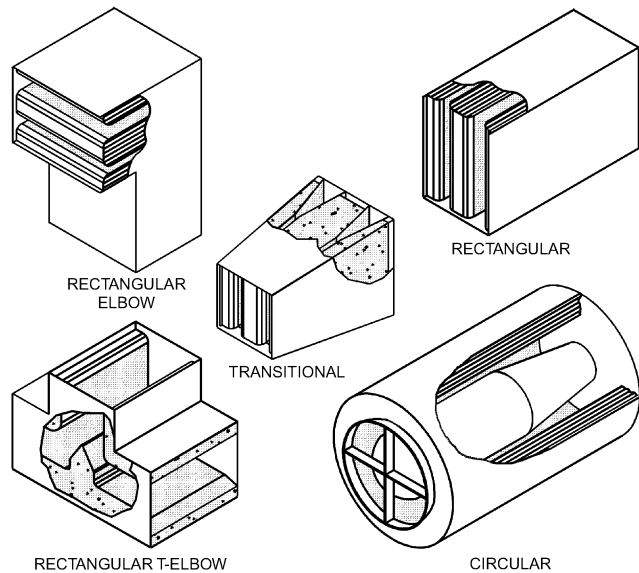
All silencers can be rated for (1) insertion loss, (2) dynamic insertion loss, (3) pressure drop, and (4) self-generated noise in accordance with ASTM Standard E477 test standards. As such, the performance is under rather ideal conditions as seen in Figure 22.

**Insertion loss** is the reduction in the sound power level at the receiver after the silencer is installed ("inserted") in the system.

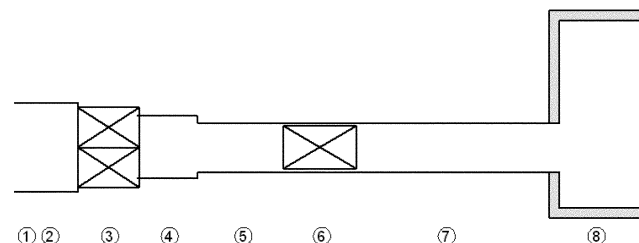
**Table 24 Insertion Loss of Unlined and Lined Square Elbows with Turning Vanes**

	Insertion Loss, dB	
	Unlined Elbows	Lined Elbows
$fw < 48$	0	0
$48 \leq fw < 96$	1	1
$96 \leq fw < 190$	4	4
$190 \leq fw < 380$	6	7
$fw > 380$	4	7

Note:  $f$  = center frequency, kHz, and  $w$  = width, mm



**Fig. 21 Duct Silencer Configurations**



- 1 - Airflow measurement station
- 2 - System fan
- 3 - System silencer
- 4 - Signal source chamber
- 5 - Pressure test station
- 6 - Straight silencer under test
- 7 - Pressure test station
- 8 - Reverberation room

**Fig. 22 Typical Facility for Rating Straight Duct Silencers With or Without Airflow**

Insertion loss is measured as a function of frequency and commonly published in full octave bands ranging from 63 to 8000 Hz.

**Dynamic insertion loss** is insertion loss with given airflow direction and velocity. A silencer's insertion loss varies depending on whether sound is traveling in the same or opposite direction as airflow. Silencer performance changes with absolute duct velocity. However, airflow velocity generally does not significantly affect silencers giving a pressure drop of 90 Pa or less, including system effects.

**Pressure drop** is measured across the silencer at a given velocity. Good flow conditions are required for accurate measurements at both the inlet and discharge of the silencer. The measuring points are usually 2.5 to 5 duct diameters upstream and downstream of the

**Table 25 Insertion Loss for Lined Flexible Duct**

Diameter, mm	Length, m	Insertion Loss, dB						
		Octave Midband Frequency, Hz						
		63	125	250	500	1000	2000	4000
100	3.7	6	11	12	31	37	42	27
	2.7	5	8	9	23	28	32	20
	1.8	3	6	6	16	19	21	14
	0.9	2	3	3	8	9	11	7
125	3.7	7	12	14	32	38	41	26
	2.7	5	9	11	24	29	31	20
	1.8	4	6	7	16	19	21	13
	0.9	2	3	4	8	10	10	7
150	3.7	8	12	17	33	38	40	26
	2.7	6	9	13	25	29	30	20
	1.8	4	6	9	17	19	20	13
	0.9	2	3	4	8	10	10	7
175	3.7	9	12	19	33	37	38	25
	2.7	6	9	14	25	28	29	19
	1.8	4	6	10	17	19	19	13
	0.9	2	3	5	8	9	10	6
200	3.7	8	11	21	33	37	37	24
	2.7	6	8	16	25	28	28	18
	1.8	4	6	11	17	19	19	12
	0.9	2	3	5	8	9	9	6
225	3.7	8	11	22	33	37	36	22
	2.7	6	8	17	25	28	27	17
	1.8	4	6	11	17	19	18	11
	0.9	2	3	6	8	9	9	6
250	3.7	8	10	22	32	36	34	21
	2.7	6	8	17	24	27	26	16
	1.8	4	5	11	16	18	17	11
	0.9	2	3	6	8	9	9	5
300	3.7	7	9	20	30	34	31	18
	2.7	5	7	15	23	26	23	14
	1.8	3	5	10	15	17	16	9
	0.9	2	2	5	8	9	8	5
350	3.7	5	7	16	27	31	27	14
	2.7	4	5	12	20	23	20	11
	1.8	3	4	8	14	16	14	7
	0.9	1	2	4	7	8	7	4
400	3.7	2	4	9	23	28	23	9
	2.7	2	3	7	17	21	17	7
	1.8	1	2	5	12	14	12	5
	0.9	1	1	2	6	7	6	2

Note: 63 Hz insertion loss values estimated from higher-frequency insertion loss values.

silencer to avoid turbulent flow areas near the silencer and to allow for any static pressure regain. For nonideal installations, with duct elbows or transitions closer than 2.5 to 5 duct diameters, the total system effect will be larger than the laboratory test data.

**Airflow-generated self noise** is the sound power generated on the receiving side by the silencer when quiet air flows through it. This represents the **noise floor**, or the lowest level achievable regardless of high insertion loss values. A silencer's self-generated noise is a function of frequency and internal geometry, and is referenced to specific velocities and airflow direction (forward or reverse). The airflow-generated sound power of the silencer is logarithmically proportional to silencer cross-sectional area. Self noise generally does not vary with silencer length.

**Table 26 Duct Branch Sound Power Division**

$S_{Bi}/\Sigma S_{Bi}$	$\Delta L_{Bi}$	$S_{Bi}/\Sigma S_{Bi}$	$\Delta L_{Bi}$
1.00	0	0.10	10
0.80	1	0.08	11
0.63	2	0.063	12
0.50	3	0.050	13
0.40	4	0.040	14
0.32	5	0.032	15
0.25	6	0.025	16
0.20	7	0.020	17
0.16	8	0.016	18
0.12	9	0.012	19

There are three types of HVAC duct silencers: dissipative (with acoustic media), fiber-free reactive (no media), and active.

**Dissipative Silencers.** Dissipative silencers use sound-absorptive media such as fiberglass as the primary means of attenuating sound; mineral wool can be used in high-temperature applications but may contain too much contamination (“shot”) for commercial HVAC applications. Usually, the absorptive medium is covered by perforated metal to protect it from erosion by airflow. If internal silencer velocities are high (faster than 23 m/s), media erosion may be further reduced by a layer of material such as fiberglass cloth or polymer film liner placed between the absorptive media and the perforated metal. Dissipative silencers may be supplied as hospital-grade or as film-lined silencers that include special polymer film linings to prevent contamination of the airstream by acoustical media fibers and prevent particles from the airstream from getting into the media. These silencers are commonly used in hospitals, pharmaceutical facilities, cleanrooms, and other places where indoor air quality is of paramount concern. Consult manufacturers for construction and testing performance details.

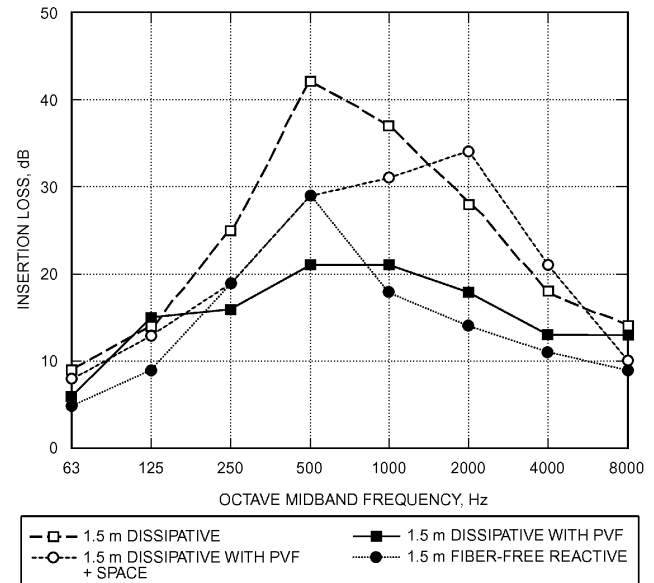
Dissipative silencer performance is primarily a function of silencer length; airflow constriction; number, thickness, and shape of splitters or centerbodies; and type and density of absorptive media. The absorptive media allows dissipative silencers to provide significant insertion loss performance over a wide frequency range.

Insertion loss performance does not necessarily increase linearly with silencer length; for a given length, silencer designs can produce varying insertion loss and pressure drop data. Even at the same pressure drop and length, silencers can be configured to provide varying insertion loss performance across the frequency spectrum.

**Reactive Silencers.** Reactive silencers are constructed only of metal, both solid and perforated, with chambers of specially designed shapes and sizes behind the perforated metal that are tuned as resonators to react with and reduce sound power at certain frequencies. The outward appearance of reactive silencers is similar to that of their dissipative counterparts. However, because of tuning, insertion loss over a wide frequency range is more difficult to achieve. Longer lengths may be required to achieve similar insertion loss performance as dissipative silencers. Airflow generally increases the insertion loss of reactive silencers.

**Figure 23** compares insertion loss of dissipative silencers, with and without protective film materials, against that of a reactive silencer for the same pressure drop.

**Active Silencers.** Active duct silencers, sometimes called noise canceling systems, produce inverse sound waves that cancel noise primarily at low frequencies. An input microphone measures noise in the duct and converts it to electrical signals, which are processed digitally to generate opposite, mirror-image sound signals of equal amplitude. A secondary noise source destructively interferes with the primary noise and cancels a significant portion of it. An error microphone measures residual sound beyond the silencer and provides



**Fig. 23 Comparison of 1.5 m Long Dissipative and Fiber-Free Reactive Silencer Performance**

Because components are mounted outside the airflow, there is no pressure loss or airflow-generated noise. Performance is limited, however, if excessive turbulence is detected by the microphones. Manufacturers recommend using active silencers where duct velocities are less than 7.6 m/s and where duct configurations are conducive to smooth, evenly distributed airflow.

Active silencers have significant low-frequency insertion loss, and are self-regulating because, if fan noise levels increase, an active silencer can increase performance to compensate for the increased source noise. Mid- and high-frequency insertion loss is minimal, however, so if required, combinations of active (for low-frequency components) and passive (for mid- and high-frequency components) can be used to achieve insertion loss over a wide frequency range.

**Test Standard.** Data for dissipative and reactive silencers should be obtained from tests consistent with the procedures outlined in ASTM Standard E477. (This standard has not been verified for determining performance of active silencers.) Because insertion loss measurements use a substitution technique, reasonably precise insertion loss values can be achieved ( $\pm 3$  dB down to 125 Hz, and  $\pm 5$  dB at lower frequencies). Airflow-generated noise values can be obtained with similar accuracy. Round-robin tests performed at several manufacturers’ and independent testing laboratories showed that airflow-generated sound power data have an expected standard deviation of  $\pm 3$  to 6 dB over the octave band frequency range of 125 to 8000 Hz. (For normal distribution, uncertainty with a 95% confidence interval is about two standard deviations.)

**Silencer Selection Issues.** When selecting a duct silencer, consider the following:

- Insertion loss required to achieve required room sound criteria
- Allowable pressure drop (if no specific requirement, then keep under 90 Pa, including system effects; when system effects are unknown, keep under 50 Pa, excluding system effects) at system duct velocity
- Silencer location and available space
- Amount of airflow-generated noise that can be tolerated
- Indoor air quality concerns
- Duct configuration

**Table 27 Approximate Silencer System Effect Factors**

Silencer Condition	Pressure Drop Factor*
Inlet (within 3 to 4 duct diameters)	
Straight unobstructed duct	1.0
Free air/plenum with smooth inlet	1.05
Radiused elbow, with turning vanes	1.05
no turning vanes	1.1
Miter elbow	1.3
Free air/plenum with sharp inlet	1.1 to 1.30
Fan	1.1 to 1.3
Outlet (within 3 to 4 duct diameters)	
Straight unobstructed duct	1.0
Duct doubles area abruptly	1.4
Radiused elbow, with turning vanes	1.5
no turning vanes	1.9
Miter elbow	2.0
Abrupt expansion/plenum	2.0
Fan	1.2 to 1.4

\*Silencer pressure drop (including system effects) = silencer pressure drop per test code  $\times$  pressure drop factor (inlet)  $\times$  pressure drop factor (outlet).

#### Insertion Loss Issues

To determine the insertion loss required, analyze the duct system, summing noise-generating mechanisms and subtracting attenuation elements (not including the silencer). The silencer's required insertion loss is the amount by which the estimated resultant sound pressure level in the space exceeds the room criteria for the space. The user should consider both the sound path through the ductwork and outlets as well as potential locations where sound may break out of the ductwork.

#### Allowable Pressure Drop Issues

Care should be taken in applying test data to actual project installations. Adverse aerodynamic system effects can significantly affect silencer performance. That is, if the silencer is located where less-than-ideal conditions exist on the inlet and/or the discharge of the silencer (3 to 5 duct diameters of straight duct), then the silencer's effective **pressure drop (PD)** is increased (total silencer PD = silencer PD per ASTM *Standard* E477 + system effect losses). In some situations, the added system effect losses can be greater than the silencer's pressure drop. Some manufacturers give guidelines for estimated pressure loss increases from varying silencer inlet and discharge configurations (Table 27); these should be considered as general guidelines. Substantial variations can occur depending on the type of silencer, its internal geometry, size of silencer, size of duct, airflow turbulence, etc. For example, an elbow fitting located immediately after a silencer prevents regain of the silencer's leaving velocity pressure. In addition, local velocities in the elbow fitting are greater than the average duct velocity that produces higher overall static pressure losses.

#### Silencer Location Issues

Silencers should generally be located as close to the noise source as possible but far enough away to allow a uniform flow profile to develop. This helps contain noise at the source and limits potential points where unsilenced noise may break out. However, because turbulent airflow usually exists close to noise sources such as fans, valves, dampers, etc., the user should carefully evaluate aerodynamic system effects.

A straight silencer has a lower first cost than a transitional or elbow silencer. If space limitations prohibit effective use of a straight silencer, or if pressure drop (including system effects) is greater than the loss allowed, use of elbow or transitional silencers should be evaluated. Special fan inlet and discharge silencers,

**Table 28 Duct End Reflection Loss (ERL): Duct Terminated Flush with Wall**

Duct Diameter, mm	End Reflection Loss, dB				
	Octave Midband Frequency, Hz				
	63	125	250	500	1000
150	18	12	7	3	1
200	15	10	5	2	1
250	14	8	4	1	0
300	12	7	3	1	0
400	10	5	2	1	0
510	8	4	1	0	0
610	7	3	1	0	0
710	6	2	1	0	0
810	5	2	1	0	0
910	4	2	0	0	0
1220	3	1	0	0	0
1830	1	0	0	0	0

including cone and inlet box silencers, minimize aerodynamic system effects, and contain noise at the source.

#### Airflow-Generated Noise Issues

In most installations, airflow-generated noise is much less than, and does not contribute to, the reduced noise level on the receiver side of the silencer. This is especially true if the silencer is properly located close to the source. In general, airflow-generated noise should be evaluated if pressure drops exceed 90 Pa (including system effects), the noise criterion is below NC/RC 35, or if the silencer is located very close to or in the occupied space.

To evaluate airflow-generated noise, sum the noise-generating mechanisms (from noise source to silencer) and subtract the attenuation elements (including silencer) in the order they occur to determine the resultant sound power level on the quiet side of the silencer. This resultant level must be summed logarithmically with the silencer's generated noise (referenced to actual duct velocities, inlet and discharge configurations, and cross-sectional area). If the generated noise is more than 10 dB below the residual sound, then the silencer's generated noise will have no effect on system noise levels.

**Duct End Reflection Loss.** When low-frequency sound waves encounter the end of a duct that is terminated into a large room, some of the incident sound energy is reflected back into the duct. Duct **end reflection loss (ERL)** values for a duct terminated flush with a wall are shown in Table 28.

To use Table 28 for a rectangular duct, calculate the effective duct diameter  $D$  by

$$D = \sqrt{4A/\pi} \quad (11)$$

where  $A$  is the cross-sectional area of the rectangular duct ( $m^2$ ). For the frequency range and duct sizes of interest to HVAC designers, the duct ERL may be accurately computed using a simplified equation (Cunefare and Michaud 2008) of the form

$$ERL = 10 \log_{10} \left[ 1 - \left( \frac{a_1 c_o}{\pi f D} \right)^{a_2} \right] \quad (12)$$

where

$c_o$  = speed of sound (dimensionally consistent with  $D$ ), m/s

$f$  = frequency, Hz

$a_1$  and  $a_2$  = dimensionless constants determined as follows:

Termination	$a_1$	$a_2$
Flush	0.7	2
Free space	1	2

ERL varies slightly with the frequency spectrum and measurement bandwidth. The constants apply to a pink spectrum in octave bands, which is representative of HVAC noise. ERLs greater than 20 dB are difficult to confirm in practice. Many test standards, such as AHRI *Standard* 260 for ducted equipment, limit ERL to 14 dB when reporting equipment sound power levels.

There are many limitations associated with the use of the ERL equation. Free-space conditions may not exist, except for duct terminations of  $5D$  or more from a reflecting plane such as a wall or the floor. Such conditions may exist in test laboratories, but are not typical of HVAC duct applications.

Research (Cunefare and Michaud 2008) has changed our understanding of ERL for ducts terminated with commercial devices. Ducts that terminate with blade-type diffusers and grilles should be treated as having ERL for a flush termination. This includes terminal devices mounted in suspended acoustical ceiling systems. Slot diffusers characterized by high aspect ratios and mounted in a rigid baffle have frequency-independent ERL that may be determined by the analytical expression for the area ratio of the diffuser to duct cross-sectional area. Finally, using flexible duct upstream of diffusers, grilles and other terminal devices reduces ERL to near zero above 63 Hz for all terminal devices. This research suggests that a significant amount of the low-frequency sound that would normally be reflected back into the duct from an open termination is either transmitted through the flexible duct or radiated by the termination. There is however a frequency-independent ERL associated with the area change in the transition to the flexible duct.

Finally, ERL values are based on analytical assumptions and empirical data for long and straight duct sections. Many air distribution

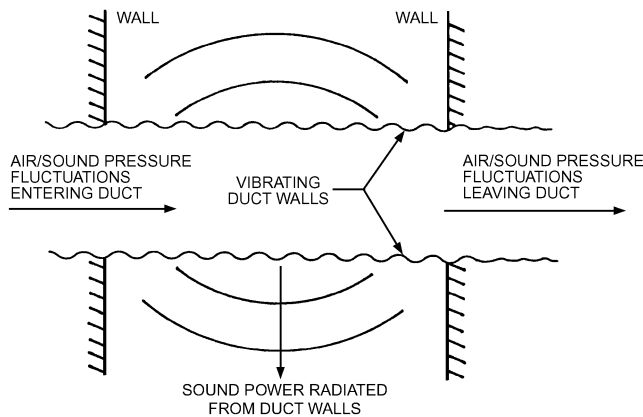
systems do not have long straight sections (greater than  $3D$ ) before they terminate into a room. Many duct sections between a main feed branch and a diffuser may be curved or short. The effects of these configurations on duct end reflection loss are not known. [Table 28](#) can be used with reasonable accuracy for many diffuser configurations. However, use caution when a diffuser configuration differs from the conditions used to derive these ERL values.

**Sound Radiation Through Duct Walls**

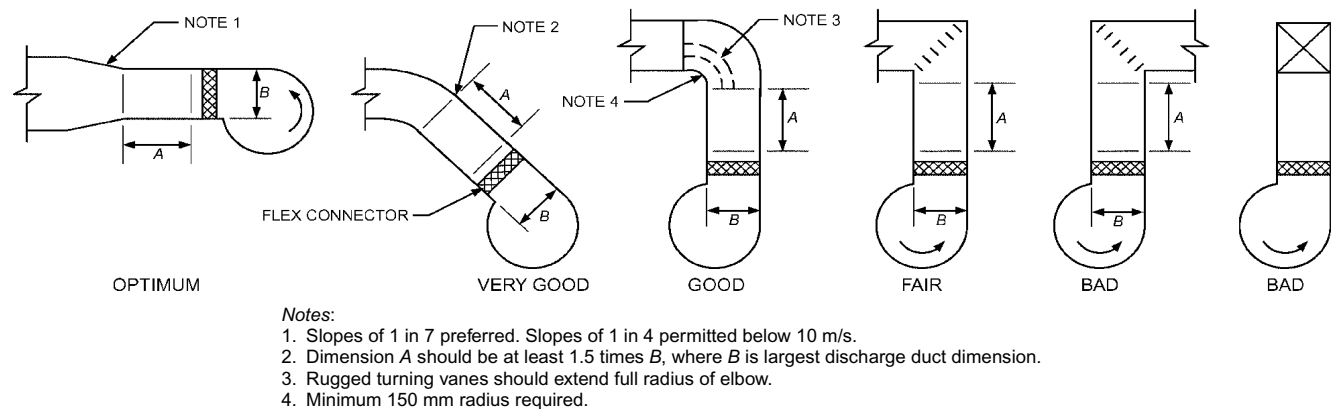
**Duct Rumble.** Duct rumble is low-frequency sound generated by vibration of a flat duct surface. The vibration is caused when an HVAC fan and its connected ductwork act as a semiclosed, compressible-fluid pumping system; both acoustic and aerodynamic air pressure fluctuations at the fan are transmitted to other locations in the duct system. Rumbling occurs at the duct’s resonance frequencies (Ebbing et al. 1978), and duct rumble levels of 65 to 95 dB in the 16 to 100 Hz frequency range have been measured in occupied spaces. With belt-driven fans, the rumble sound level fluctuates above and below the mean dB level by 5 to 25 dB at a rate of 2 to 10 “beats” per second (Blazier 1993). The most common beat frequency occurs at the difference between the fan rpm and twice the belt frequency (belt rpm = fan sheave diameter × sheave rpm ×  $\pi$ /belt length). As shown in [Figure 24](#), duct rumble is dependent on the level of duct vibration. The very low resonant frequencies at which duct rumble occurs means that the sound wavelengths are very long (3 to 20 m), and the rumble can exert sound energy over long distances. Low-mass architectural structures such as metal frame and drywall systems near a source of duct rumble can easily vibrate and rattle in sympathy to the rumble.

Case histories indicate that duct vibration is much more prevalent when there is a dramatic change in airflow direction near the fan, and at large, flat, unreinforced duct surfaces (usually greater than 1200 mm in any dimension) near the fan. Problems can occur with dimensions as small as 460 mm if high noise levels are present. [Figure 25](#) shows duct configurations near a centrifugal fan. Good to optimum designs of fan discharge transitions minimize potential for duct rumble; however, this may not completely eliminate the potential for duct rumble, which also depends heavily on flow turbulence at the fan wheel, duct stiffness, air velocity in the duct, and duct resonant characteristics.

Duct liner, sound attenuators, and duct lagging with mass-loaded vinyl over fiberglass do not reduce duct rumble. One approach to eliminate or reduce rumble is to alter the fan or motor speed, which changes the frequency of air pressure fluctuations so that they differ from duct wall resonance frequencies. Another method is to apply rigid materials, such as duct reinforcements and drywall, directly to the duct wall to change the wall resonance frequencies ([Figure 26](#)).



**Fig. 24 Transmission of Rumble Noise Through Duct Walls**



**Fig. 25 Various Outlet Configurations for Centrifugal Fans and Their Possible Rumble Conditions**

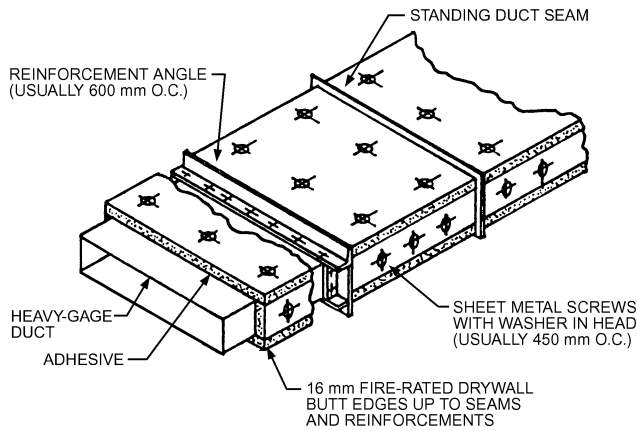


Fig. 26 Drywall Lagging for Duct Rumble

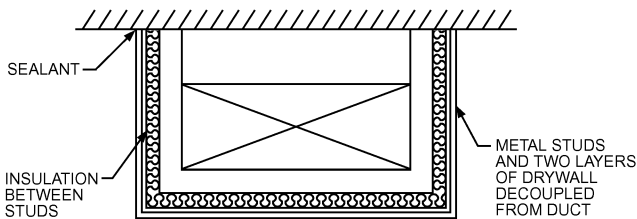


Fig. 27 Decoupled Drywall Enclosure for Duct Rumble

Noise reductions of 5 to 11 dB in the 31.5 and 63 Hz octave frequency bands are possible using this treatment.

Mass-loaded materials applied in combination with absorptive materials do not alleviate duct rumble noise unless both materials are completely decoupled from the duct by a large air separation (preferably greater than 150 mm). The mass-loaded material should have a surface density greater than 20 kg/m<sup>2</sup>. An example of this type of construction, using two layers of drywall, is shown in Figure 27. Because the treatment is decoupled from the duct wall, it provides the greatest noise reduction. Mass-loaded/absorptive material directly attached to a round duct can be an effective noise control treatment for high-frequency noise above the duct rumble frequency range of 16 to 100 Hz. In addition, the stiffness of round ductwork prevents flexure of the duct wall. Where space allows, round ductwork is an effective method to prevent duct rumble (Harold 1986). However, unless round ducts are used throughout the primary duct system, duct rumble can be still generated at a remote point where round duct is converted to rectangular or flat oval.

Round ducts can have a resonant ring resonance frequency, which depends on duct material and diameter. The ring frequency is a resonance frequency that occurs where the circumference of the duct is equal to the wavelength of the bending waves in the duct wall. On rare occasions, loud in-duct noise, such as blade-pass frequency noise from a centrifugal or axial fan, can excite this resonance. In all cases, this resonance causes an increase in radiated noise in the frequency region close to the ring frequency.

**Sound Breakout and Break-In from Ducts.** Breakout is sound associated with fan or airflow noise inside a duct that radiates through duct walls into the surrounding area (Figure 28). Breakout can be a problem if it is not adequately attenuated before the duct runs over an occupied space (Cummings 1983; Lilly 1987). Sound that is transmitted into a duct from the surrounding area is called break-in (Figure 29). The main factors affecting breakout and break-in sound transmission are the transmission loss of the duct, total exposed surface area of the duct, and presence of any acoustical duct liner.

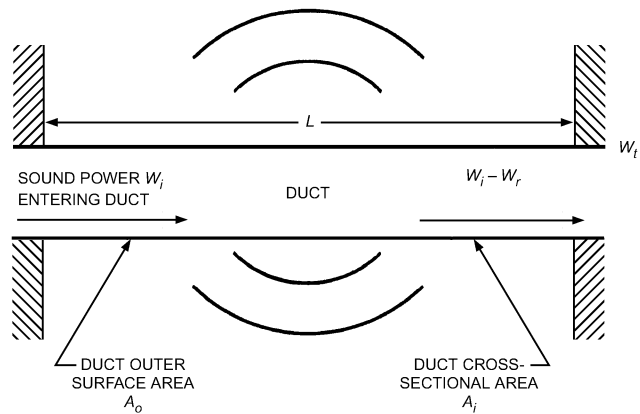


Fig. 28 Breakout Noise

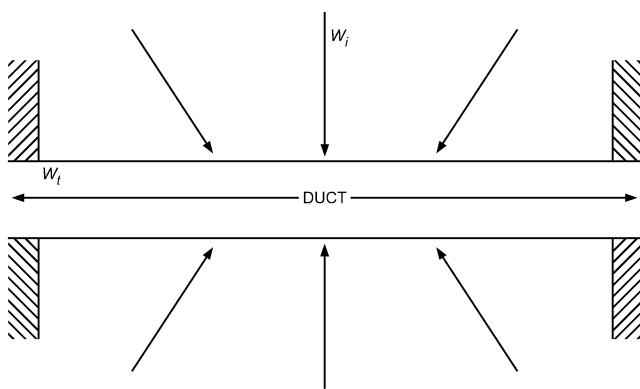


Fig. 29 Break-In Noise

**Transmission loss (TL)** is the ratio of sound power incident on a partition to the sound power transmitted through a partition. This ratio varies with acoustic frequency as well as duct shape, size, and wall thickness. Higher values of transmission loss result in less noise passing through the duct wall.

**Breakout sound transmission from ducts** is the sound transmitted through a duct wall and then radiated from the exterior surface of the duct wall. Its sound power level is given by

$$L_{w(out)} = L_{w(in)} + 10 \log \left( \frac{S}{A} \right) - TL_{out} \quad (13)$$

where

$L_{w(out)}$  = sound power level of sound radiated from outer surface of duct walls, dB

$L_{w(in)}$  = sound power level of sound inside duct, dB

$S$  = surface area of outer sound-radiating surface of duct, m<sup>2</sup>

$A$  = cross-section area of inside of duct, m<sup>2</sup>

$TL_{out}$  = normalized duct breakout transmission loss (independent of  $S$  and  $A$ ), dB

Equation (13) is a simplified expression that assumes that the sound power level inside the duct does not decrease with distance over the length of the duct. In fact, for very long ducts (when  $S \gg A$ ), the radiated sound power level  $L_{w(out)}$  could become greater than the sound power level inside the duct, which would violate the conservation of energy principle. A more accurate expression for breakout is presented in Equation (20).

Values of  $TL_{out}$  for rectangular ducts are given in Table 29, for round ducts in Table 30, and for flat oval ducts in Table 31 (Cummings 1983, 1985; Lilly 1987).

**Table 29** TL<sub>out</sub> Versus Frequency for Rectangular Ducts

Duct Size, mm	Gage	TL <sub>out</sub> , dB							
		Octave Midband Frequency, Hz							
		63	125	250	500	1000	2000	4000	8000
305 × 305	24	21	24	27	30	33	36	41	45
305 × 610	24	19	22	25	28	31	35	41	45
305 × 1220	22	19	22	25	28	31	37	43	45
610 × 610	22	20	23	26	29	32	37	43	45
610 × 1220	20	20	23	26	29	31	39	45	45
1220 × 1220	18	21	24	27	30	35	41	45	45
1220 × 2440	18	19	22	25	29	35	41	45	45

Note: Data are for duct lengths of 6.1 m, but values may be used for cross section shown regardless of length.

**Table 30** Experimentally Measured TL<sub>out</sub> Versus Frequency for Round Ducts

Diameter, Length, mm m	Gage	Octave Midband Frequency, Hz							
		63	125	250	500	1000	2000	4000	
<b>Long Seam Ducts</b>									
200	4.6	26	>45	(53)	55	52	44	35	34
350	4.6	24	>50	60	54	36	34	31	25
560	4.6	22	>47	53	37	33	33	27	25
810	4.6	22	(51)	46	26	26	24	22	38
<b>Spiral Wound Ducts</b>									
300	3.6	26*	52	51	53	51	50	46	36
610	7.3	24	51	53	51	44	36	26	29
	7.3	24*	51	51	54	44	39	33	47
	3	16	>48	53	36	32	32	28	41
915	7.3	20	51	51	52	46	36	32	55

\*Ducts internally lined with 25 mm thick 24 kg/m<sup>3</sup> fiberglass with 0.6 mm perforated sheet metal inner liner.

**Table 31** TL<sub>out</sub> Versus Frequency for Flat Oval Ducts

Duct Size, mm	Gage	TL <sub>out</sub> , dB							
		Octave Midband Frequency, Hz							
		63	125	250	500	1000	2000	4000	
305 × 152	24	31	34	37	40	43	—	—	
610 × 152	24	24	27	30	33	36	—	—	
610 × 305	24	28	31	34	37	—	—	—	
1220 × 305	22	23	26	29	32	—	—	—	
1220 × 610	22	27	30	33	—	—	—	—	
2440 × 610	20	22	25	28	—	—	—	—	
2440 × 1220	18	28	31	—	—	—	—	—	

Note: Data are for duct lengths of 6.1 m, but values may be used for cross section shown regardless of length.

Equations for *S* and *A* for rectangular ducts are

$$S = 2L(a + b) \tag{14}$$

$$A = ab \tag{15}$$

where

*a* = larger duct cross-section dimension, m

*b* = smaller duct cross-section dimension, m

*L* = length of duct sound-radiating surface, m

Equations for *S* and *A* for round ducts are

$$S = L\pi d \tag{16}$$

$$A = \pi \frac{d^2}{4} \tag{17}$$

where

*d* = duct diameter, m

*L* = length of duct sound-radiating surface, m

For flat oval ducts,

$$S = L[2(a - b) + \pi b] \tag{18}$$

$$A = b(a - b) + \frac{\pi b^2}{4} \tag{19}$$

where

*a* = length of major axis, m

*b* = length of minor axis, m

*L* = length of duct sound-radiating surface, m

Equation (13) assumes no decrease in the internal sound power level with distance along the length of the duct. Thus, it is valid only for relatively short lengths of unlined duct. For long ducts or ducts that have internal acoustic lining, one approach is to divide the duct into sections, each of which is short enough to be modeled as a section of duct with constant internal sound power level over the length of each section. The recommended maximum length of each section is the length that would result in a 1 dB reduction in the internal sound power level at the frequency of interest. Alternatively, the total sound power radiated from any duct of any length (including an internally lined duct) can be calculated in a single step with a modified version of Equation (13) (Lilly 1987):

$$L_{w(out)} = L_{w(in)} + 10 \log \left( \frac{S^*}{A} \right) - TL_{out} \tag{20}$$

where *S\** is the effective surface area of the duct. *S\** = *PL\**, where *P* = duct perimeter, and *L\** = effective length. The effective length *L\** is calculated as

$$L^* = \frac{\gamma^L - 1}{\ln \gamma} \tag{21}$$

where

$$\gamma = 10^{-(\alpha/10)} \tag{22}$$

where  $\alpha$  = duct attenuation rate, dB/m (see Tables 16 to 21). For lined rectangular ducts, Tables 17 and 18 do not have data at 63 Hz. For rough approximations, use Table 16 values.

In most rooms where the listener is close to the duct, an estimate of the breakout sound pressure level can be obtained from

$$L_p = L_{w(out)} - 10 \log(\pi r L) \tag{23}$$

where

*L<sub>p</sub>* = sound pressure level at a specified point in the space, dB

*L<sub>w(out)</sub>* = sound power level of sound radiated from outer surface of duct walls, given by Equation (13) or Equation (20), dB

*r* = distance between duct and position for which *L<sub>p</sub>* is calculated, m

*L* = length of the duct sound-radiating surface, m

Note that Equation (23) gives sound pressure from a duct that is in a wide-open ceiling plenum space. If the duct is in a tight space between floor slab and ceiling, it may be up to 6 dB louder.

**Example 4.** A 610 mm by 610 mm by 7.5 m long rectangular supply duct is constructed of 0.75 mm sheet metal. Given the following sound power levels in the duct, what are the breakout sound pressure levels 1.5 m from the surface of the duct?

**Solution:** Using Equations (13) and (23),

	Octave Midband Frequency, Hz						
	63	125	250	500	1000	2000	4000
<i>L<sub>w(in)</sub></i>	90	85	80	75	70	65	60
-TL <sub>out</sub> (Table 29)	-20	-23	-26	-29	-32	-37	-43
10 log( <i>S</i> / <i>A</i> )	17	17	17	17	17	17	17
<i>L<sub>w(out)</sub></i>	89	79	71	63	55	45	34
-10 log( $\pi r L$ )	-16	-16	-16	-16	-16	-16	-16
<i>L<sub>p</sub></i> , dB	71	62	55	47	39	29	18

Using Equations (21) to (23),

	Octave Midband Frequency, Hz						
	63	125	250	500	1000	2000	4000
$L_{w(in)}$	90	85	80	75	70	65	60
$-TL_{out}$ (Table 29)	-20	-23	-26	-29	-32	-37	-43
$\alpha$ , dB/m (Table 16)	0.82	0.66	0.33	0.10	0.10	0.10	0.10
$\gamma$	0.94	0.95	0.98	0.99	0.99	0.99	0.99
$L^*$ , m	4.0	4.5	5.7	6.9	6.9	6.9	6.9
$10 \log(S^*/A)$	14	15	16	17	17	17	17
$L_{w(out)}$	84	77	70	63	55	45	34
$-10 \log(\pi rL)$	-16	-16	-16	-16	-16	-16	-16
$L_{pp}$ , dB	68	61	54	47	39	29	18

**Example 5.** Repeat Example 4, but with 50 mm thick internal duct liner.

**Solution:** Using Equations (13) and (23),

	Octave Midband Frequency, Hz						
	63	125	250	500	1000	2000	4000
$L_{w(in)}$	90	85	80	75	70	65	60
$-TL_{out}$ (Table 29)	-20	-23	-26	-29	-32	-37	-43
$10 \log(S/A)$	17	17	17	17	17	17	17
$L_{w(out)}$	87	79	71	63	55	45	34
$-10 \log(\pi rL)$	-16	-16	-16	-16	-16	-16	-16
$L_{pp}$ , dB	71	63	55	47	39	29	18

Using Equations (21) to (23),

	Octave Midband Frequency, Hz						
	63	125	250	500	1000	2000	4000
$L_{w(in)}$	90	85	80	75	70	65	60
$-TL_{out}$ (Table 29)	-20	-23	-26	-29	-32	-37	-43
$\alpha$ , dB/m (Table 18)	0.5	1.0	3.0	8.2	11.5	7.2	5.9
$\gamma$	0.94	0.93	0.81	0.56	0.45	0.60	0.66
$L^*$ , m	5.0	3.6	1.4	0.5	0.4	0.6	0.7
$10 \log(S^*/A)$	14	14	10	5	4	6	7
$L_{w(out)}$	84	76	64	51	42	34	24
$-10 \log(\pi rL)$	-16	-16	-16	-16	-16	-16	-16
$L_{pp}$ , dB	68	60	48	35	26	18	8

**Example 6.** Repeat Example 5 using 610 mm diameter spiral round duct, with 0.6 mm, 7.6 m long with 25 mm thick acoustical duct lining.

**Solution:** Using Equations (21) and (23),

	Octave Midband Frequency, Hz						
	63	125	250	500	1000	2000	4000
$L_{w(in)}$	90	85	80	75	70	65	60
$-TL_{out}$ (Table 30)	-51	-51	-54	-44	-39	-33	-47
$10 \log(S/A)$	17	17	17	17	17	17	17
$L_{w(out)}$	56	51	43	48	48	49	30
$-10 \log(\pi rL)$	-16	-16	-16	-16	-16	-16	-16
$L_{pp}$ , dB	40	35	27	32	32	33	14

Using Equations (21) to (23) yields

	Octave Midband Frequency, Hz						
	63	125	250	500	1000	2000	4000
$L_{w(in)}$	90	85	80	75	70	65	60
$-TL_{out}$ (Table 30)	-51	-51	-54	-44	-39	-33	-47
$\alpha$ , dB/m (Table 20)	0.23	0.82	1.87	4.2	5.61	4.07	2.79
$\gamma$	0.95	0.83	0.65	0.38	0.27	0.39	0.53
$L^*$ , m	6.2	4.0	2.2	1.0	0.8	1.1	1.5
$10 \log(S^*/A)$	16	14	12	8.3	7.1	8.5	10
$L_{w(out)}$	55	48	38	39	38	40	23
$-10 \log(\pi rL)$	-16	-16	-16	-16	-16	-16	-16
$L_{pp}$ , dB	39	32	22	23	22	25	7

**Table 32** Experimentally Measured  $TL_{in}$  Versus Frequency for Circular Ducts

Diameter, Length, mm m	Gage	$TL_{in}$ , dB							
		Octave Midband Frequency, Hz							
		63	125	250	500	1000	2000	4000	
<b>Long Seam Ducts</b>									
203	4.57	26	>17 (31)	39	42	41	32	31	
356	4.57	24	>27	43	43	31	31	28	22
559	4.57	22	>28	40	30	30	30	24	22
813	4.57	22	(35)	36	23	23	21	19	35
<b>Spiral Wound Ducts</b>									
203	3.05	26	>20 >42	>59	>62	53	43	26	
356	3.05	26	>20 >36	44	28	31	32	22	
660	3.05	24	>27	38	20	23	22	19	33
660	3.05	16	>30 >41	30	29	29	25	38	
813	3.05	22	>27	32	25	22	23	21	37

Note: In cases where background sound swamped sound radiated from duct walls, a lower limit on  $TL_{in}$  is indicated by >. Parentheses indicate measurements in which background sound produced greater uncertainty than usual.

**Table 33**  $TL_{in}$  Versus Frequency for Rectangular Ducts

Duct Size, mm	Gage	$TL_{in}$ , dB							
		Octave Midband Frequency, Hz							
		63	125	250	500	1000	2000	4000	8000
305 × 305	24	16	16	16	25	30	33	38	42
305 × 610	24	15	15	17	25	28	32	38	42
305 × 1220	22	14	14	22	25	28	34	40	42
610 × 610	22	13	13	21	26	29	34	40	42
610 × 1220	20	12	15	23	26	28	36	42	42
1220 × 1220	18	10	19	24	27	32	38	42	42
1220 × 2440	18	11	19	22	26	32	38	42	42

Note: Data are for duct lengths of 6.1 m.

Using round duct eliminates the low-frequency rumble present with rectangular ducts but introduces some mid- and high-frequency noise that can be reduced by adding duct liner as shown.

When sound is not transmitted through the wall of a round duct, it propagates down the duct and may become a problem at another point in the duct system. Round flexible and rigid fiberglass ducts do not have high transmission loss properties because they lack the mass or stiffness associated with round sheet metal ducts.

Whenever duct sound breakout is a concern, fiberglass or flexible round duct should not be used; these ducts have little or no transmission loss, and are essentially transparent to sound.

**Break-in sound transmission into ducts** is sound transmitted into a duct through the duct walls from the space outside the duct. Its sound power level is given by

$$L_{w(in)} = L_{w(out)} - TL_{in} - 3 \tag{24}$$

where

- $L_{w(in)}$  = sound power level of sound transmitted into duct and then transmitted upstream or downstream of point of entry, dB
- $L_{w(out)}$  = sound power level of sound incident on outside of duct walls, dB
- $TL_{in}$  = duct break-in transmission loss, dB

Values for  $TL_{in}$  for rectangular ducts are given in Table 32, for round ducts in Table 33, and for flat oval ducts in Table 34 (Cummings 1983, 1985).

## 2.5 RECEIVER ROOM SOUND CORRECTION

The sound pressure level at a given location in a room caused by a particular sound source is a function of the sound power level and sound radiation characteristics of the sound source, acoustic properties of the room (surface treatments, furnishings, etc.), room

**Table 34**  $TL_{in}$  Versus Frequency for Flat Oval Ducts

Duct Size, mm	Gage	$TL_{in}$ , dB						
		Octave Midband Frequency, Hz						
		63	125	250	500	1000	2000	4000
305 × 152	24	18	18	22	31	40	—	—
610 × 152	24	17	17	18	30	33	—	—
610 × 305	24	15	16	25	34	—	—	—
1220 × 305	22	14	14	26	29	—	—	—
1220 × 610	22	12	21	30	—	—	—	—
2440 × 610	20	11	22	25	—	—	—	—
2440 × 1220	18	19	28	—	—	—	—	—

Note: Data are for duct lengths of 6.1 m.

volume, and distance between the sound source and point of observation. Two types of sound sources are typically encountered in HVAC system applications: **point** and **line**. Typical point sources are grilles, registers, and diffusers; air-valve and fan-powered air terminal units and fan-coil units located in ceiling plenums; and return air openings. Line sources are usually associated with sound breakout from air ducts and long slot diffusers.

For a point source in an enclosed space, classical diffuse-field theory predicts that as the distance between the source and point of observation is increased, the sound pressure level initially decreases at the rate of 6 dB per doubling of distance. At some point, the reverberant sound field begins to dominate and the sound pressure level remains at a constant level.

For point sound sources in **reflective unfurnished rooms**, the classic diffuse equation for converting sound power to pressure could be used:

$$L_p = L_w + 10 \log(Q/4\pi r^2 + 4/R) \quad (25)$$

where

- $L_p$  = sound pressure level, dB (re 20 μPa)
- $L_w$  = sound power level, dB (re 10<sup>-12</sup> W)
- $Q$  = directivity of sound source, dimensionless; see Figure 30
- $r$  = distance from source, m
- $R$  = room constant =  $[S\alpha/(1 - \alpha)]$  = sum of all surface areas and their corresponding absorption coefficients, m<sup>2</sup>

A further discussion of assumptions used in converting power to pressure is available in Chapter 8 of the 2013 *ASHRAE Handbook—Fundamentals*.

However, investigators have found that diffuse-field theory does not apply in rooms with furniture or other sound-scattering objects (Schultz 1985; Thompson 1981). Instead, sound pressure levels decrease at the rate of around 3 dB per doubling of distance between sound source and point of observation. Generally, a true reverberant sound field does not exist in small rooms (room volumes less than 425 m<sup>3</sup>). In larger rooms reverberant fields usually exist, but typically at distances from the sound sources that are significantly greater than those predicted by diffuse-field theory.

Most **normally furnished rooms** of regular proportions have acoustic characteristics that range from *average* to *medium dead*. These usually include carpeted rooms with sound-absorptive ceilings. If such a room has a volume less than 425 m<sup>3</sup> and the sound source is a single point source, sound pressure levels associated with the sound source can be obtained from (Schultz 1985).

$$L_p = L_w - 10 \log r - 5 \log V - 3 \log f + 12 \quad (26)$$

or

$$L_p = L_w + A - B \quad (27)$$

where

- $L_p$  = sound pressure level at specified distance from sound source, dB (re 20 μPa)
- $L_w$  = sound power level of sound source, dB (re 10<sup>-12</sup> W)

**Table 35** Values for  $A$  in Equation (26)

Room Volume, m <sup>3</sup>	Value for $A$ , dB						
	Octave Midband Frequency, Hz						
	63	125	250	500	1000	2000	4000
42	4	3	2	1	0	-1	-2
71	3	2	1	0	-1	-2	-3
113	2	1	0	-1	-2	-3	-4
170	1	0	-1	-2	-3	-4	-5
283	0	-1	-2	-3	-4	-5	-6
425	-1	-2	-3	-4	-5	-6	-7

**Table 36** Values for  $B$  in Equation (26)

Distance from Sound Source, m	Value for $B$ , dB
0.9	5
1.2	6
1.5	7
1.8	8
2.4	9
3.0	10
4.0	11
4.9	12
6.1	13

**Table 37** Values for  $C$  in Equation (28)

Distance from Sound Source, m	Value for $C$ , dB						
	Octave Midband Frequency, Hz						
	63	125	250	500	1000	2000	4000
0.9	5	5	6	6	6	7	10
1.2	6	7	7	7	8	9	12
1.5	7	8	8	8	9	11	14
1.8	8	9	9	9	10	12	16
2.4	9	10	10	11	12	14	18
3.0	10	11	12	12	13	16	20
4.0	11	12	13	13	15	18	22
4.9	12	13	14	15	16	19	24
6.1	13	15	15	16	17	20	26
7.6	14	16	16	17	19	22	28
9.8	15	17	17	18	20	23	30

- $r$  = distance from source to receiver, m
- $V$  = volume of room, m<sup>3</sup>
- $f$  = frequency

Values for  $A$  and  $B$  are given in Tables 35 and 36.

In an alternative calculation for a normally furnished room with volume greater than 425 m<sup>3</sup> and a single-point sound source, sound pressure levels associated with the sound source can be obtained from

$$L_p = L_w - C - 5 \quad (28)$$

Values for  $C$  are given in Table 37. Equation (28) can be used for room volumes of up to 4250 m<sup>3</sup>, with accuracy typically within 2 to 5 dB.

### Distributed Array of Ceiling Sound Sources

In many office buildings, air supply outlets are located flush with the ceiling of the conditioned space and constitute an array of distributed ceiling sound sources. The geometric pattern depends on the floor area served by each outlet, ceiling height, and thermal load distribution. In interior zones of a building where thermal load

requirements are essentially uniform, air delivery per outlet is usually the same throughout the space; thus, these outlets emit nominally equal sound power levels. One way to calculate sound pressure levels in a room with a distributed array is to use Equation (26), (27), or (28) to calculate the sound pressure levels for each individual air outlet at specified locations in the room and then logarithmically add the sound pressure levels for each diffuser at each observation point. This procedure can be very tedious for a room with a large number of ceiling air outlets.

For a distributed array of ceiling sound sources (air outlets) of nominally equal sound power, room sound pressure levels tend to be uniform in a plane parallel to the ceiling. Although sound pressure levels decrease with distance from the ceiling along a vertical axis, they are nominally constant along any selected horizontal plane. Equation (29) simplifies calculation for a distributed ceiling array. For this case, use a reference plane 1.5 m above the floor.

Thus,  $L_{p(1.5)}$  is obtained from

$$L_{p(1.5)} = L_{W(s)} - D \quad (29)$$

where

$L_{p(1.5)}$  = sound pressure level at distance of 1.5 m above floor, dB (re 20  $\mu$ Pa)

$L_{W(s)}$  = sound power level of single diffuser in array, dB (re  $10^{-12}$  W)

Values of  $D$  are given in Table 38.

### Nonstandard Rooms

The previous equations assume that the acoustical characteristics of a room range from average to medium dead, which is generally true of most rooms. However, some rooms may be acoustically *medium live to live* (i.e., they have little sound absorption). These rooms may be sports or athletic areas, concert halls, or other rooms designed to be live, or they may be rooms that are improperly designed from an acoustic standpoint. The previous equations should not be used for acoustically live rooms because they can overestimate the decrease in sound pressure levels associated with room sound correction by as much as 10 to 15 dB. When these or other types of nonstandard rooms are encountered, it is best to use the services of an acoustical engineer.

### Line Sound Sources

Sound from breakout from air ducts or long slot diffusers may be modeled as line sources. To convert sound power levels to the corresponding sound pressure levels in a room for such cases, the following equation may be used:

$$L_p = L_W + 10 \log(Q/\pi r L + 4/R) \quad (30)$$

where

$L_p$  = sound pressure level, dB (re 20  $\mu$ Pa)

$L_W$  = sound power level, dB (re  $10^{-12}$  W)

$Q$  = 1 if line source is away from reflecting surfaces; 2 if line source is near a flat reflective surface.

$r$  = distance from source, m

$L$  = length of line source, m

$R$  = room constant =  $[S\alpha/(1 - \alpha)]$  = sum of all surface areas and their corresponding absorption coefficients,  $m^2$

This is the classic diffuse room equation for a line source, and may not produce accurate results for standard nondiffuse rooms. Unfortunately, no information is available at this time on how to correct more accurately for the effect of the receiver room on line sources.

### Room Noise Measurement

Measuring HVAC system noise in a room is complicated by several factors, including the spatial and temporal variability of the noise, variable HVAC system operating conditions, modal characteristics of the room, and intrusion of noise from exterior sources. How noise measurements should be taken depends to some extent on the purpose of the measurement. Is the purpose of the measurement to verify that the noise level in the room meets a specific criteria, or is it meant to troubleshoot an alleged problem? The specific measurement requirements vary depending on the intent.

For commissioning purposes, there are two levels of assessment: (1) a survey method may be used to make a quick assessment of a space and (2) an engineering method for a more detailed and accurate assessment. The **survey approach** is typically used to assess whether there may be a noise problem in the room. This method requires a Type 1 integrating sound level meter equipped with octave band filters if octave band levels are specified by the applicable noise criterion. Measurements can be taken at a single point or at several points, but all measurement points must be at a likely location for the listener's ears. No measurement locations may be less than 1 m from a room boundary or less than 0.5 m from any object in the room. The measurement microphone must be fixed (or slowly moving) for each measurement, and the minimum duration of each measurement is 15 s. It is recognized that HVAC noise is a time-varying signal, so the energy average sound pressure level  $L_{eq}$  must be compared against the noise criterion, not the maximum sound level recorded during the measurement.

If the survey method detects a potential noise problem or if a complaint has been registered by an occupant of the space, the **engineering method** may be implemented if compliance with a noise level specification is required. This method uses the same instrumentation but requires a minimum of four separate measurement locations, uniformly distributed throughout the room. For larger rooms (greater than 20  $m^2$ ), additional measurement points must be added, proportional to the floor area of the room. Unless specified otherwise, the energy average  $L_{eq}$  of all measurement locations in the room is compared against the noise criterion.

If the purpose of the noise measurement is troubleshooting a known problem, more sophisticated instrumentation (e.g., narrow band analyzers, vibration sensors, intensity probes) may be required. Troubleshooting work should be provided by a competent acoustical consultant with specific experience in this field of work. Contact the Institute of Noise Control Engineering ([www.inceusa.org](http://www.inceusa.org)) or the National Council of Acoustical Consultants ([www.ncac.com](http://www.ncac.com)) for a list of experts.

In any case, it is important for the operating conditions of the HVAC system to be known at the time of the measurements. If the system contains compressors that cycle on and off during normal operation, the measurements must be taken while the compressors are running. For variable-volume systems, the measurements should be taken at design (maximum) volume. If the condition rarely operates under design flow conditions, measurements must also be taken at a more typical operating condition.

**Table 38 Values for  $D$  in Equation (29)**

Floor Area per Diffuser, $m^2$	Value for $D$ , dB						
	Octave Midband Frequency, Hz						
	63	125	250	500	1000	2000	4000
Ceiling height 2.4 to 2.7 m							
9.3 to 14	2	3	4	5	6	7	8
18.5 to 23	3	4	5	6	7	8	9
Ceiling height 3.0 to 3.7 m							
14 to 18.5	4	5	6	7	8	9	10
23 to 28	5	6	7	8	9	10	11
Ceiling height 4.3 to 4.9 m							
23 to 28	7	8	9	10	11	12	13
32.5 to 37	8	9	10	11	12	13	14

It is also important to make sure that noise from extraneous (non-HVAC) sources does not contaminate the measurements. Room noise measurements may be corrected for these sounds by taking one set of measurements with the HVAC system operating under test conditions and additional measurements with the HVAC system shut down entirely. This correction can only be applied if the ambient noise is shown to be relatively constant with time. If the energy average of two independent ambient noise level measurements (one obtained before and the other obtained after the HVAC system noise measurement) is more than 6 dB below the HVAC noise level in any octave band, then the ambient adjusted HVAC noise level in that octave band may be computed using the following equation:

$$L_{p \text{ ambient adjusted}} = 10 \log \left[ 10^{(L_{p \text{ HVAC}}/10)} - 10^{(L_{p \text{ ambient}}/10)} \right]$$

where

$L_{p \text{ HVAC}}$  = sound pressure level with HVAC system operating  
 $L_{p \text{ ambient}}$  = energy average ambient sound pressure level with HVAC system off

The ambient noise correction cannot be allowed if the difference between the two ambient noise levels in any frequency band is more than 3 dB. If this occurs, the ambient noise is not constant with time and the entire set of measurements should be repeated. Remember that that the ambient noise correction is not required.

For more information, see the section on Troubleshooting.

## 2.6 SOUND CONTROL FOR OUTDOOR EQUIPMENT

Outdoor mechanical equipment should be carefully selected, installed, and maintained to minimize sound radiated by the equipment, and to comply with local noise codes. Equipment with strong tonal components is more likely to provoke complaints than equipment with a broadband noise spectrum.

### Sound Propagation Outdoors

If the equipment sound power level spectrum and ambient sound pressure level spectrum are known, the contribution of the equipment to the sound level at any location can be estimated by analyzing the sound transmission paths involved. When there are no intervening barriers and no attenuation because of berms, ground absorption, or atmospheric effects, the principal factor in sound pressure level reduction is distance. The following equation may be used to estimate the sound pressure level of equipment at a distance from it and at any frequency when the sound power level is known:

$$L_p = L_w + 10 \log Q - 20 \log d - 11 \quad (31)$$

where

$d$  = distance from acoustic center of source to distant point, m  
 $L_p$  = sound pressure level at distance  $d$  from sound source, dB  
 $L_w$  = sound power level of sound source, dB  
 $Q$  = directivity factor associated with way sound radiates from sound source (see Figure 30)

Equation (31) does not apply where  $d$  is less than twice the maximum dimension of the sound source.  $L_p$  may be low by up to 5 dB where  $d$  is between two and five times the maximum sound source dimension. Also, if the distance is greater than about 150 m, wind, thermal gradients, and atmospheric sound absorption need to be considered.

For complex cases, refer to texts on acoustics (e.g., Beranek 1971) and international standards such as ISO Standard 9613-2.

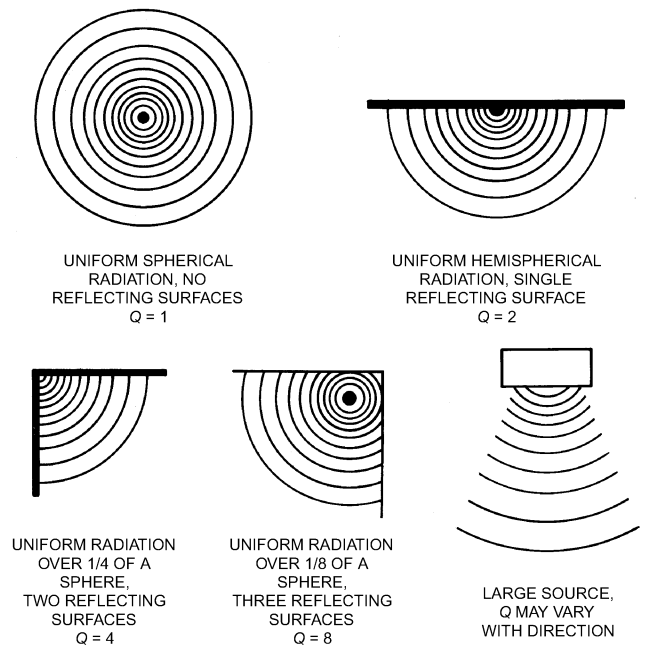


Fig. 30 Directivity Factors for Various Radiation Patterns

### Sound Barriers

A sound barrier is a solid structure that intercepts the direct sound path from a sound source to a receiver. It reduces the sound pressure level within its shadow zone. Figure 31 illustrates the geometrical aspects of an outdoor barrier where no extraneous surfaces reflect sound into the protected area. Here the barrier is treated as an intentionally constructed noise control structure. If a sound barrier is placed between a sound source and receiver location, the sound pressure level  $L_p$  in Equation (26) is reduced by the **insertion loss (IL)** associated with the barrier.

Table 39 gives the insertion loss of an outdoor ideal solid barrier when no surfaces reflect sound into the shadow zone, and the sound transmission loss of the barrier wall or structure is at least 10 dB greater at all frequencies than the insertion loss expected of the barrier. The path-length difference referred to in Table 39 is given by

$$\text{Path-length difference} = A + B - D \quad (32)$$

where  $A$ ,  $B$ , and  $D$  are as specified in Figure 31.

The limiting value of about 24 dB is caused by sound scattering and refracting into the shadow zone formed by the barrier. Practical factors such as size and space restrictions often limit sound barrier performance to 10 to 15 dBA. For large distances outdoors, this scattering and bending of sound waves into the shadow zone reduces barrier effectiveness. At large distances, atmospheric conditions can significantly affect sound path losses by amounts even greater than those provided by the barrier, with typical differences of 10 dBA. For a conservative estimate, the height of the sound source location should be taken as the topmost part of the sound source, and the height of the receiver should be taken as the topmost location of a sound receiver, such as the top of the second-floor windows in a two-floor house or at a height of 1.5 m for a standing person.

**Reflecting Surfaces.** No other surfaces should be located where they can reflect sound around the ends or over the top of the barrier into the barrier shadow zone. Figure 32 shows examples of reflecting surfaces that can reduce the effectiveness of a barrier wall.

**Width of Barrier.** Each end of the barrier should extend horizontally beyond the line of sight from the outer edge of the source to the outer edge of the receiver position by a distance of at least

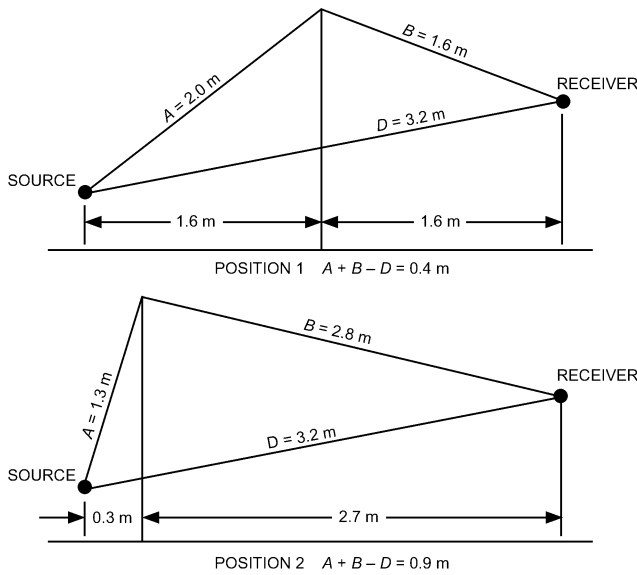


Fig. 31 Noise Barrier

Table 39 Insertion Loss Values of Ideal Solid Barrier

Path-Length Difference, m	Insertion Loss, dB							
	Octave Midband Frequency, Hz							
	31	63	125	250	500	1000	2000	4000
0.003	5	5	5	5	5	6	7	8
0.006	5	5	5	5	5	6	8	9
0.015	5	5	5	5	6	7	9	10
0.03	5	5	5	6	7	9	11	13
0.06	5	5	6	8	9	11	13	16
0.15	6	7	9	10	12	15	18	20
0.3	7	8	10	12	14	17	20	22
0.6	8	10	12	14	17	20	22	23
1.5	10	12	14	17	20	22	23	24
3.0	12	15	17	20	22	23	24	24
6.1	15	18	20	22	23	24	24	24
15.2	18	20	23	24	24	24	24	24

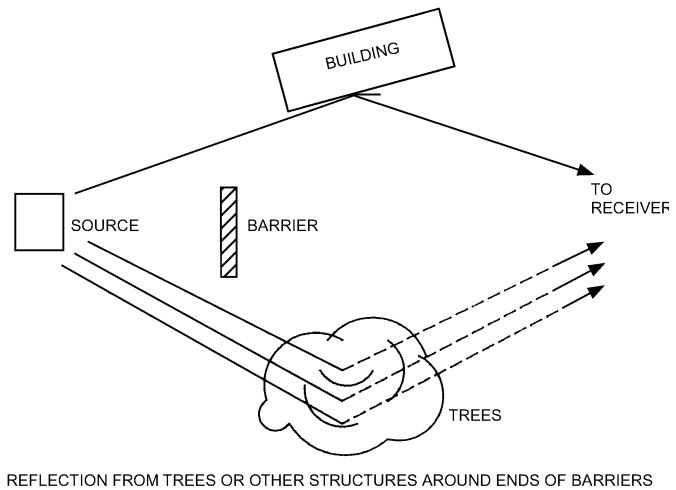
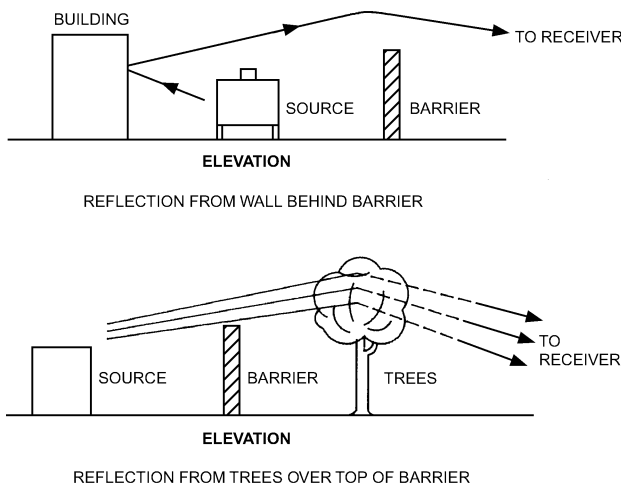


Fig. 32 Reflecting Surfaces That Can Diminish Barrier Effectiveness

three times the path-length difference. Near the ends of the barrier, the effectiveness of the noise isolation is reduced because some sound is diffracted over the top and around the ends. Also, some sound is reflected or scattered from various nonflat surfaces along the ground near the ends of the barrier. In critical situations, the barrier should completely enclose the sound source to eliminate or reduce the effects of reflecting surfaces.

**Reflection from a Barrier.** A large, flat reflecting surface, such as a barrier wall, may reflect more sound toward the source than there would have been with no wall present. If the wall produces no special focusing effect, reflections from the wall will produce levels on the side of the barrier facing the source that are 2 to 3 dB higher. Using acoustical absorption on the barrier surface (source side) reduces this increase.

### 2.7 FUME HOOD DUCT DESIGN

Fume hood exhaust systems are often the major sound source in a laboratory. The exhaust system may consist of individual exhaust fans ducted to separate fume hoods, or a central exhaust fan connected through a collection duct system (commonly known as a manifold) to a large number of hoods, as shown in Figure 33. In either case, a redundancy system consisting of two fans might be used. In addition to fan noise, other sound sources are the air terminal unit serving the hood and aerodynamically generated noise from airflow in the ducts and control valves. Sound pressure levels produced in the laboratory space should be estimated using procedures described in this section and manufacturer-supplied noise emission data. Recommended noise level design criteria for laboratory spaces using fume hoods are given in Table 1.

To minimize static pressure loss and fan power consumption in a duct system, fume hood ducts should be sized to allow rated airflow at no greater than 10 m/s or at a velocity consistent with regulatory requirements. Duct velocities over 10 m/s should be avoided for acoustical reasons and to conserve energy. Above this speed, the design criteria given in Table 1 are unlikely to be met, even with a silenced fan(s).

Noise control measures for fume hood systems include the following:

**Fan(s)**

- Where conditions allow, use backward-inclined, airfoil, or forward-curved centrifugal fans instead of radial-blade fans, and use caution if applying axial-blade fans.

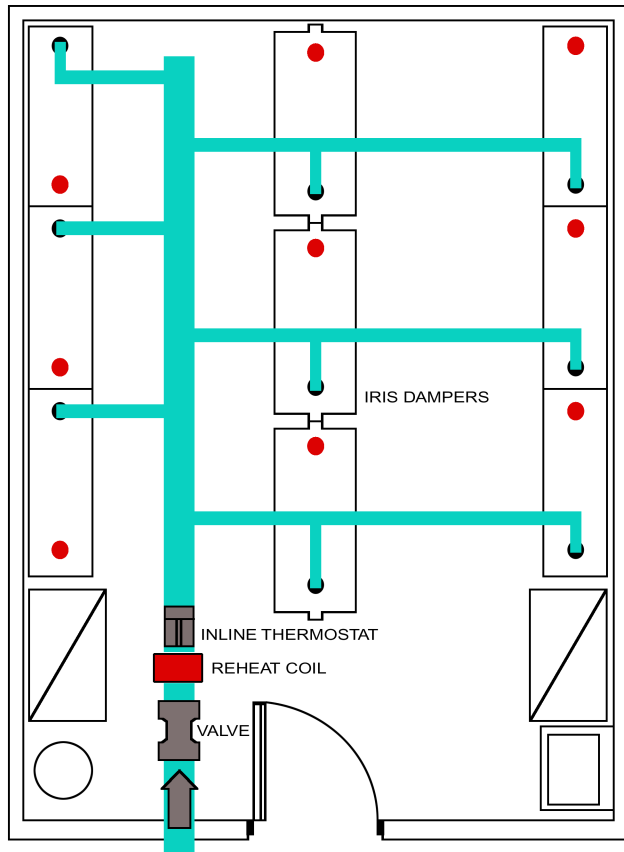


Fig. 33 Typical Manifold Lab Exhaust Layout

- Select fan(s) to operate at a low tip speed and maximum efficiency.
- Try to run redundant fans at reduced capacity instead of operating one fan at full capacity.

#### Manifold

- Design the manifold upstream of the exhaust fan(s) to double as an acoustic plenum as shown in Figure 34 with sound-absorbent sidewall panels, which can be constructed with nonporous lining or packless cavities with perforated inner wall. Fan low-frequency noise can be reduced when the manifold is parallel-piped, with large surface area compared to the cross-sectional area of the fume hood ducts connecting to it.

#### Duct silencers

- Use prefabricated duct silencers or sections of lined ducts where conditions allow. In addition to galvanized steel, silencers can be fabricated with stainless steel, aluminum, or plastic.
- Silencers should be packless design, or have nonporous fill.

#### Exhaust silencers

- Where outdoor noise is an issue, round silencers may be required between the fan and the discharge cone. These should be packless or nonporous-fill design.

#### Duct design

- Design duct elements such as elbows and junctions with low friction to minimize duct pressure loss and aerodynamically generated noise. Use round ducts, because rectangular ducts can have a noise breakout issue.

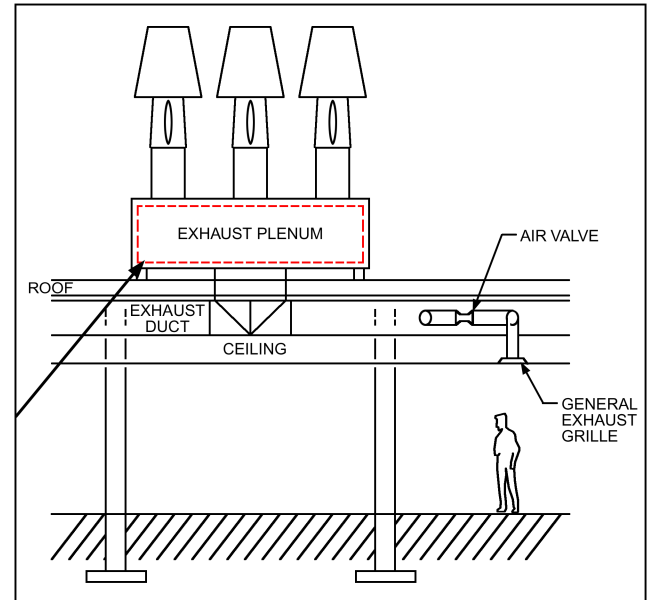


Fig. 34 Inlet Plenum for Multiple Exhaust Fans

#### Laboratory flow control valves and air terminal units

- Allow 600 to 900 mm minimum of straight duct upstream and downstream from the terminal unit to reduce aerodynamically generated noise at the unit.
- Additional straight length may be required on the room side of valves to accommodate high-performance silencers.
- Noise generation in flow control valves increases exponentially with pressure loss, so system supply or exhaust pressure should be set at the level necessary to achieve design flow rate with minimal safety factor.

#### Fume hood location

- Where possible, locate fume hoods in private alcoves to reduce lab occupant's noise exposure.

All potential noise control measures should be carefully evaluated for compliance with applicable codes, safety requirements, and corrosion resistance requirements of the specific fume hood system. In addition, vibration isolation for fume hood exhaust fans is generally required. For some laboratory facilities, particularly those with highly vibration-sensitive instruments such as electron microscopes, vibration control can be critical, and a vibration specialist should be consulted.

## 2.8 MECHANICAL EQUIPMENT ROOM SOUND ISOLATION

#### Location

Locating HVAC equipment in a common room allows the designer to control noise affecting nearby spaces. Often, these spaces have background noise level criteria that dictate the type of construction and treatment necessary to achieve sufficient reduction in equipment noise transmitted to other spaces.

The most effective noise control measure for indoor mechanical equipment rooms is to locate them as far away as possible from noise-sensitive areas. In some cases, this requires a separate structure, such as a central chiller plant, to house equipment. Subterranean basement locations are typically best for noisy equipment because the basement usually affects the fewest adjacent locations. Penthouse equipment rooms are common but can create significant challenges for noise and vibration isolation. Rooms containing air-handling units should provide sufficient room for the equipment and

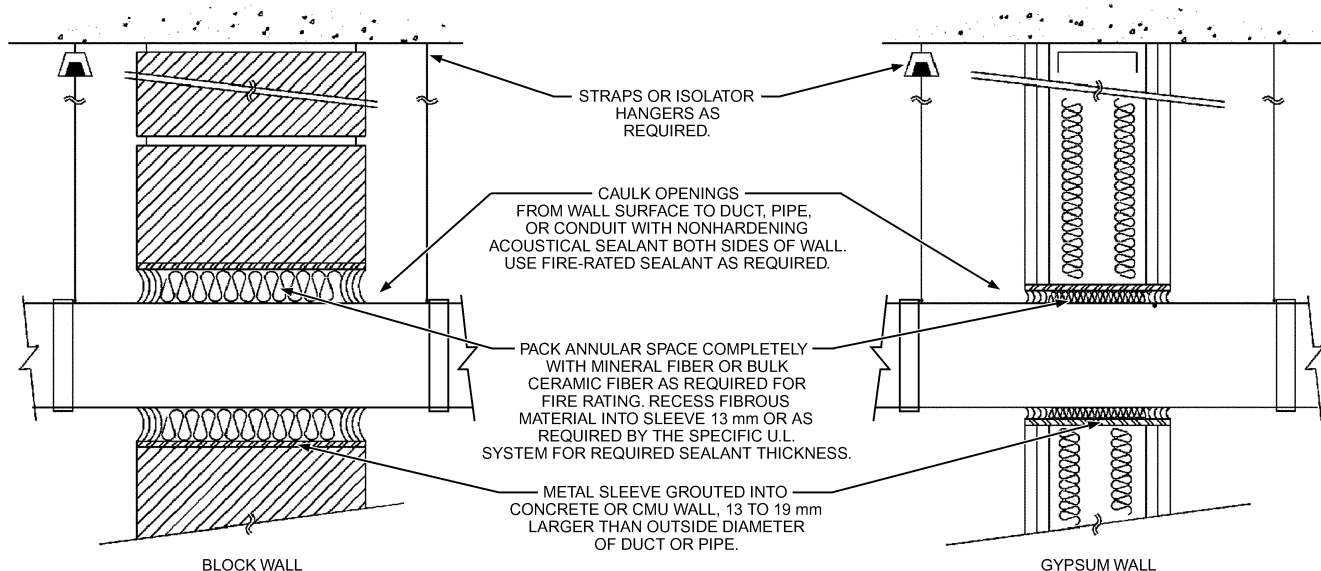


Fig. 35 Duct, Conduit, and Pipe Penetration Details

Table 40 Sound Transmission Class (STC) and Transmission Loss Values of Typical Mechanical Equipment Room Wall, Floor, and Ceiling Types, dB

Room Construction Type	STC	Octave Midband Frequency, Hz						
		63	125	250	500	1000	2000	4000
200 mm CMU*	50	35	35	41	44	50	57	64
200 mm CMU with 16 mm GWB* on furring strips	53	33	32	44	50	56	59	65
16 mm GWB on both sides of 92 mm metal studs	38	18	16	33	47	55	43	47
16 mm GWB on both sides of 92 mm metal studs with fiberglass insulation in cavity	49	16	23	44	58	64	52	53
2 layers of 16 mm GWB on both sides of 92 mm metal studs with fiberglass insulation in cavity	56	19	32	50	62	67	58	63
Double row of 92 mm metal studs, 25 mm apart, each with 2 layers of 16 mm GWB and fiberglass insulation in cavity	64	23	40	54	62	71	69	74
150 mm solid concrete floor/ceiling	53	40	40	40	49	58	67	76
150 mm solid concrete floor with 100 mm isolated concrete slab and fiberglass insulation in cavity	72	44	52	58	73	87	97	100
150 mm solid concrete floor with two layers of 16 mm GWB hung on spring isolators with fiberglass insulation in cavity	84	53	63	70	84	93	104	105

Note: Actual material composition (e.g., density, porosity, stiffness) affects transmission loss and STC values.

\*CMU = concrete masonry unit; GWB = gypsum wallboard.

associated ductwork to allow smooth transitions and full-radius curved elbows. A building corner location can work well by reducing the number of adjacent interior spaces and the amount of associated outdoor-air ductwork. Using adjacent spaces such as corridors, closets, and storage rooms as buffer zones can provide effective noise control. A common mistake in locating mechanical equipment rooms is to position the room in the core of the building between a stairway, an elevator shaft, and a telecommunications closet, leaving only one wall where supply and return air ductwork can enter and leave the room. This leads to high-velocity air in the ductwork and high static pressures for fans to overcome, leading to higher noise levels.

Once the mechanical equipment room location has been established, the amount of noise created in the room should be assessed and appropriate constructions selected for walls, ceilings, and floors. Concrete masonry units of various available thickness and densities are often used for their durability and effectiveness in reducing low-frequency noise levels. Typically, heavier and thicker materials contain more sound within the space. Special masonry

units that provide a limited amount of acoustical absorption using slotted openings and resonator cavities can also be used. The sound isolation of a masonry wall can be significantly improved by using furred-out gypsum wallboard and insulation in cavities. Chillers and other equipment with very high noise levels are best situated in rooms with concrete masonry unit walls.

### Wall Design

Often, because of structural issues and mass limitations, mechanical equipment room walls are built from gypsum wallboard on metal or wood studs. To adequately attenuate low-frequency noise, sufficient mass and thickness must be provided in the wall partition construction. This typically entails using multiple layers of gypsum wallboard on both sides of the wall with batt insulation in the cavities. Where greater levels of noise reduction are required, walls are built on double, staggered-stud construction using two separate rows of studs on separate tracks with multiple layers of gypsum wallboard and batt insulation in the cavities (see Table 40).

## Doors

Doors into mechanical equipment rooms are frequently the weak link in the enclosure. Where noise control is important, the doors should be as heavy as possible, gasketed around the perimeter, have no grilles or other openings, and be self-closing. If they lead to sensitive spaces, two doors separated by a 1 to 3 m corridor may be necessary.

## Penetrations

For all types of walls, service penetrations should be fully caulked and sealed. Pipes, ducts, and conduits that penetrate walls, ceilings, or floors of mechanical rooms should be acoustically treated. Typically, a 13 mm gap around the penetrating element is filled with an appropriate material such as mineral fiber insulation. The penetration is then sealed airtight with resilient caulk (Figure 35).

Ducts passing through the mechanical equipment room enclosure pose an additional problem. Sound can be transmitted to either side of the wall through duct walls. Airborne sound in the mechanical room can be transmitted into the duct (break-in) and enter an adjacent space by reradiating (breakout) from duct walls, even if the duct contains no grilles, registers, diffusers, or other openings.

Sound levels in ducts close to fans are usually high. Sound can come not only from the fan but also from pulsating duct walls, excessive air turbulence, and air buffeting caused by tight or restricted fan airflow entrance or exit configurations. Duct layout for good aerodynamics and airflow conditions should minimize low-frequency sound generation, which, once generated, is difficult or impossible to remove, especially near noise-sensitive areas. Avoid elements conducive to increased breakout noise transmission and/or with a tendency to vibrate at low frequencies because of non-laminar airflow. Round ductwork is most resistant to these problems, followed by square and rectangular ducts with aspect ratios less than 2:1. Heavier-than-normal gage metal ductwork, such as 16 ga (1.6 mm thickness) within the mechanical room and over noise-sensitive spaces, can also be used.

## Mechanical Chases

Mechanical chases and shafts should be acoustically treated the same way as mechanical equipment rooms, especially if they contain noise-producing ductwork, pipes, and equipment such as fans and pumps. The shaft should be closed at the mechanical equipment room, and shaft wall construction must provide sufficient reduction of mechanical noise from the shaft to noise-sensitive areas to obtain acceptable noise levels. Chases should not be allowed to become “speaking tubes” between spaces requiring different acoustical environments. Crosstalk through the shaft must be prevented. Pipes, ducts, conduits, or equipment should be vibration isolated so that mechanical and structureborne noise is not transmitted to the shaft walls and into the building structure.

When mechanical equipment rooms are used as supply or return plenums, all openings into the equipment room plenum space may require noise control treatment, especially if any sound-critical space is immediately adjacent. This is particularly true if the space above an acoustical tile ceiling just outside the equipment room is used as a return air plenum. Most acoustical tile ceilings are almost acoustically transparent at low frequencies.

Often, supply ducts are run inside a chase that is also used for return air. It is best to attenuate supply and return paths at the fan rather than let duct breakout noise require additional noise control at the chase return air inlets. Take care to prevent turbulent noise generation in the supply duct through proper supply duct design.

## Special Construction Types

Sound transmission loss values for some typical constructions are given in Table 40. These data are compiled from controlled laboratory tests and represent a condition typically superior to that found in field installations, because the in situ acoustical performance of any wall, floor, or ceiling is adversely affected by flanking paths, holes, penetrations, and other anomalies. Flanking paths include intersections of the wall, floor, or ceiling surface with another wall, floor, or ceiling that is structurally connected. Higher levels of sound isolation can be achieved by decoupling the surfaces and using double-walled, floating floor, or barrier-ceiling constructions.

### Floating Floors and Barrier Ceilings

Correctly installed floating floors and barrier ceilings can provide very high levels of sound isolation, allowing mechanical equipment rooms to be placed adjacent to noise-sensitive spaces. Like double-walled construction, these configurations decouple two surfaces by providing separate supporting structures. However, these types of construction can add significant cost and coordination complexity and should be carefully evaluated.

In a floating floor, the upper floor slab is typically a 100 mm concrete slab resting on spring, neoprene, and/or fiberglass vibration isolators supported by the subfloor (typically another concrete slab of appropriate thickness). An air gap is maintained between the two slabs and resilient materials are used around the upper slab’s perimeter to decouple it from surrounding walls. Air gap and upper slab thickness both affect noise isolation performance and should be considered. Any heavy equipment should be properly supported to account for additional loading and possible short circuiting.

Because natural frequencies for floating floor systems are limited by the dynamic response of the air trapped between the floating and structural slabs, these types of systems are not recommended to control structureborne vibration. It is extremely difficult on a floating floor to achieve a natural frequency of less than 15 Hz. While this is low enough to have a significant impact on audible frequencies, it is not low enough to control the vibrations generated by common equipment types.

Mounting equipment directly to a floating floor can reduce flanking paths and result in some acoustic benefits. However, ensure that adequate damping is provided in the floating floor and that there are no common natural frequencies present between the floating floor isolation system and any equipment isolation mounted to it. Improper selection can increase the transmitted vibration rather than reduce it.

Similarly, barrier ceilings are typically composed of multiple layers of gypsum wallboard attached to a frame suspended from the structure above with vibration-isolating hangers. A sound barrier ceiling’s construction is influenced by its purpose. If the ceiling isolates two vertically adjacent spaces, mechanical equipment should be placed below the ceiling to ensure a continuous drywall barrier. If noise levels in the occupied space below the sound barrier ceiling are critical, mechanical equipment should be placed above with minimal ceiling penetrations that are properly sealed. Regardless, ductwork, piping, and other equipment require careful coordination of hangers and supports to ensure no rigid contact with the ceiling. Ceiling penetrations should be minimized, because these reduce barrier ceiling performance. In the case of recessed lighting, it is often necessary to use a gypsum wallboard enclosure around the entire fixture so that it does not serve as a flanking path for noise.

Design and selection of the floating floor or ceiling should be carefully considered to properly support the dead and live loads it must carry. The floating system (floor or ceiling) is *not meant as a means of equipment vibration isolation and serves primarily to control airborne sound transmission*. Acoustical performance of the

floating system depends greatly on construction quality, which requires careful coordination between all trades. All penetrations and intersections with other surfaces must allow the floor or ceiling to float without any rigid connections. This typically entails maintaining clearances of at least 6 mm and filling all gaps with resilient materials such as nonhardening caulk.

### Sound Transmission in Return Air Systems

The fan return air system provides a sound path (through ducts or a ceiling plenum) between a fan and occupied rooms. Where there is a direct opening to the mechanical equipment room from the ceiling plenum, sound levels in adjacent spaces can be high, originating from the fan and other sources in the mechanical equipment room. Low system attenuation between the mechanical equipment room and adjacent spaces exacerbates the problem.

Fan intake sound power levels control sound in ducted return air systems; sound power levels of the fan intake and casing-radiated noise components affect plenum return air systems. In some installations, sound from other equipment located in the mechanical equipment room may also radiate through the wall opening and into adjacent spaces. Good design yields room return air system sound levels that are approximately 5 dB below the corresponding room supply air system sound levels.

When sound levels in spaces adjacent to mechanical equipment rooms are too high, noise control measures must be provided. The controlling sound paths between the mechanical equipment room and adjacent spaces must be identified. Ducted return air systems can be modified using methods applicable to ducted supply systems. Ceiling plenum return systems should only be used for spaces that are remote from mechanical equipment rooms.

Ceiling plenum systems may require additional modifications. Prefabricated silencers can be effective when installed at the mechanical equipment room wall opening or at the suction side of the fan. Improvements in ceiling transmission loss are often limited by typical ceiling penetrations and lighting fixtures. Modifications to the mechanical equipment room wall can be effective for some constructions. Adding acoustical absorption in the mechanical equipment room reduces build-up of reverberant sound energy in this space; however, this typically reduces high-frequency noise by a maximum of 4 dB and low-frequency noise only slightly in areas near the return opening.

### Sound Transmission Through Ceilings

When terminal units, fan-coil units, air-handling units, ducts, or return air openings to mechanical equipment rooms are located in a ceiling plenum above a room, sound transmission through the ceiling system can be high enough to cause excessive noise levels in that room. There is no standard test procedure for measuring direct transmission of sound through ceilings from sources close to the ceiling. As a result, ceiling product manufacturers rarely publish data that can be used in calculations. The problem is complicated by the presence of light fixtures, diffusers, grilles, and speakers that reduce the ceiling's transmission loss. Experiments have shown that, for ceiling panels supported in a T-bar grid system, leakage between the panels and grid is the major transmission path; differences among panel types are small, and light fixtures, diffusers, etc., have only a localized effect.

To estimate room sound pressure levels associated with sound transmission through the ceiling, sound power levels in the ceiling plenum must be adjusted to account for the transmission loss of the ceiling system and plenum. Measured data must also be adjusted to account for sound absorption in the room. The procedures given here are based on ASHRAE research (Warnock 1998):

1. Obtain octave band radiated sound power levels of device.
2. Subtract environmental correction from [Table 41](#).

**Table 41 Environmental Correction to Be Subtracted from Device Sound Power**

Octave Band Frequency, Hz						
63	125	250	500	1000	2000	4000
4	2	1	0	0	0	0

**Table 42 Compensation Factors for Source Area Effect**

Area range, m <sup>2</sup>			
63 Hz	125 Hz	250 Hz	Adjustment, dB
<0.24	<0.20		-3
0.26 to 0.46	0.22 to 0.43	<0.21	-2
0.47 to 0.67	0.46 to 0.66	0.25 to 0.56	-1
0.69 to 0.87	0.68 to 0.88	0.62 to 0.96	0
0.90 to 1.09	0.91 to 1.12	0.99 to 1.33	1
1.11 to 1.30	1.13 to 1.34	1.37 to 1.70	2
1.32 to 1.52	1.36 to 1.56	1.74 to 2.07	3
1.53 to 1.72	1.59 to 1.79		4
1.75 to 1.93	1.81 to 2.02		5
1.95 to 2.15			6

Note: Find correct area in each frequency column and read adjustment from last column on right.

3. Calculate surface area of bottom panel of source closest to ceiling tiles (m<sup>2</sup>).
4. From [Table 42](#), find adjustment to be subtracted from sound power values at three frequencies given there.
5. Select ceiling/plenum attenuation from [Table 43](#) according to ceiling type in use. Note that these values include a typical room effect, so when using these data in analysis, there is no additional line item from Equation (20) or (30).
6. Subtract the three sets of values, taking account of sign where necessary, from sound power values. The result is the average sound pressure level in the room.
7. The sound field in the room may be assumed as uniform up to distances of 5 m from the source.

**Example 7.** A terminal unit with an area of 1.3 m<sup>2</sup> and a known sound power level is to be used above a standard 16 mm thick mineral fiber ceiling system in a T-bar grid. What room sound pressure levels can be expected?

**Solution:**

Step	Octave Band Frequency, Hz						
	63	125	250	500	1000	2000	4000
1 Sound power	71	71	65	55	54	53	45
2 Environmental ( <a href="#">Table 41</a> )	-4	-2	-1	0	0	0	0
4 Area adjustment ( <a href="#">Table 42</a> )	-2	-2	-1	0	0	0	0
5 Ceiling/plenum ( <a href="#">Table 43</a> )	-13	-15	-17	-19	-25	-30	-33
6 Room sound pressure levels, dB	52	52	46	36	29	23	12

## 2.9 HVAC NOISE-REDUCTION DESIGN PROCEDURES

These HVAC system design procedures address the 63 to 4000 Hz octave band midfrequency range. Although it is desirable to extend this frequency range down into the 31.5 Hz octave band, acoustical calculations below the 125 Hz octave band are generally not reliable. With a few exceptions, if acoustical design criteria are met at 4000 Hz, then the 8000 Hz requirements are also met. Guidelines in this chapter and other guides maximize the probability of meeting acoustical design criteria in the 31.5 to 8000 Hz octave bands.

There is reasonable probability that the acoustical design criteria will be met when the following requirements are satisfied:

Table 43 Ceiling/Plenum/Room Attenuations in dB for Generic Ceiling in T-Bar Suspension Systems

Tile Type	Approximate Density, kg/m <sup>2</sup>	Tile Thickness, mm	Octave Midband Frequency, Hz						
			63	125	250	500	1000	2000	4000
Mineral fiber	4.9	16	13	16	18	20	26	31	36
	2.4	16	13	15	17	19	25	30	33
Glass fiber	0.5	16	13	16	15	17	17	18	19
	2.9	50	14	17	18	21	25	29	35
Glass fiber with TL backing	2.9	50	14	17	18	22	27	32	39
Gypsum board tiles	8.8	13	14	16	18	18	21	22	22
Solid gypsum board ceiling	8.8	13	18	21	25	25	27	27	28
	11.2	16	20	23	27	27	29	29	30
Double layer of gypsum board	18.1	25	24	27	31	31	33	33	34
	22	32	26	29	33	33	35	35	36
Mineral fiber tiles, concealed spline mount.	2.4 to 4.9	16	20	23	21	24	29	33	34

Source: Warnock (1998)

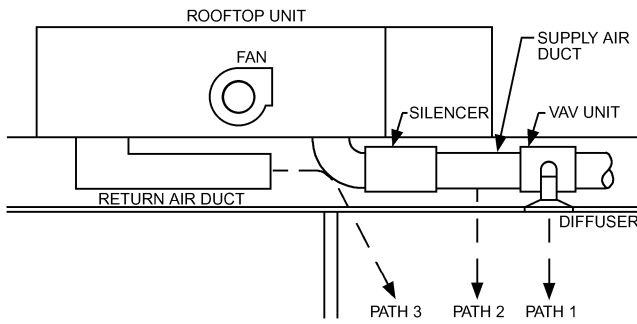
- Systems are designed in accordance with the equipment selection, placement, and integration guidelines in this chapter, other ASHRAE guides, and manufacturers' application notes and bulletins.
- Acoustical calculations based on the information included in this chapter and the information provided by the equipment manufacturer indicate that the system will not exceed the selected acoustical design criteria values in the 63 to 4000 Hz octave band frequency range.

The following suggested design procedure uses the Noise Criteria (NC) method, which is the most commonly used. Other criteria, such as NCB or RC, may be used. (See the Criteria Descriptions section of this chapter or Chapter 8 of the 2013 *ASHRAE Handbook—Fundamentals* for detailed explanations of these methods.) However, it is often difficult to acquire low-frequency sound data, and low-frequency acoustical calculations for HVAC system components are not reliable.

1. Determine the design goal for HVAC system noise for each critical area according to its use and construction. Choose the desirable NC criterion from Table 1.
2. Select equipment and fittings (e.g., air inlet and outlet grilles, registers, diffusers, and air terminal and fan-coil units that radiate sound directly into a room) that are operating comfortably with their specified duty and are quiet for the class of equipment in question. The appropriate selection of equipment and fitting will generally result in an efficient acoustic design to meet design goals.
3. Complete initial design and layout of the HVAC system. Include typical duct lining where appropriate. Provide space for duct sound attenuators. Confirm that the airflow velocities are compliant with the specified rates in Tables 8 and 9 of the Aerodynamically Generated Sound in Ducts section of this Chapter.
4. Calculate sound pressure level in the room of interest:
  - (a) Acquire sound power data from manufacturers for equipment such as air-handling units, packaged rooftop units, exhaust fans, variable-air-volume terminal units, fan-powered terminal units, etc. If manufacturers' data are not available, estimate sound power level based on methods in this chapter or other authoritative sources.
  - (b) Calculate sound attenuation and regenerated sound power of duct elements in the air distribution system of interest.
  - (c) Tabulate sound power and attenuation for each component in each sound transmission path. Start at the supply air fan or packaged air-conditioning unit and end at the room. Investigate both the supply and return air paths in similar ways. Investigate possible duct sound breakout when fans

are adjacent to, or roof-mounted fans are above, the room of interest. Combine sound power levels from all paths. See Example 8 for calculation procedures for supply and return air paths, including duct breakout noise contributions. Include a placeholder for the duct sound attenuator so that it is a simple matter to include in calculations later.

- (d) Convert sound power levels to corresponding sound pressure levels in the room using the ASHRAE room correction procedure. (See the Receiver Room Sound Correction section of this chapter.)
5. If the mechanical equipment room is adjacent to the room of interest, determine sound pressure levels in the room of interest that are associated with sound transmitted through the mechanical equipment room wall. Air-handling units, ventilation and exhaust fans, chillers, pumps, electrical transformers, and instrument air compressors are typical equipment to consider. Make sure that noise transmission from adjacent external spaces outside the room in question, such as cooling towers or air-cooled chillers, is also considered. Also consider the vibration isolation requirements for equipment, piping, and ductwork. [See Egan (1988) or Reynolds and Bledsoe (1991) for calculation procedure.]
  6. Combine on an energy basis the sound pressure levels in the room of interest that are associated with all sound paths between the mechanical equipment room or roof-mounted unit(s) and the room of interest. Establish the controlling noise-transmission paths.
  7. Determine the corresponding NC level associated with the calculated total sound pressure levels in the room of interest. Take special note of unbalanced sound spectra and tonal characteristics.
  8. If the NC level satisfies the criteria established in step 1, analysis is complete. If the NC level exceeds the design goal, determine the octave frequency bands in which the corresponding sound pressure levels are exceeded and the sound paths associated with these octave frequency bands as determined in step 6. If the resulting noise levels are high enough to cause perceivable vibration, consider both airborne and structureborne noise.
  9. Redesign the system:
    - (a) Reselect the offending noise source. This is typically the least costly, most energy-efficient, and most effective change, but is not always possible.
    - (b) Add sound attenuation to paths that contribute to excessive sound pressure levels in the room of interest. This may be achieved by using thicker internal acoustic-grade insulation or proprietary silencers. Note that silencers preferably should be inserted at the penetration of the mechanical



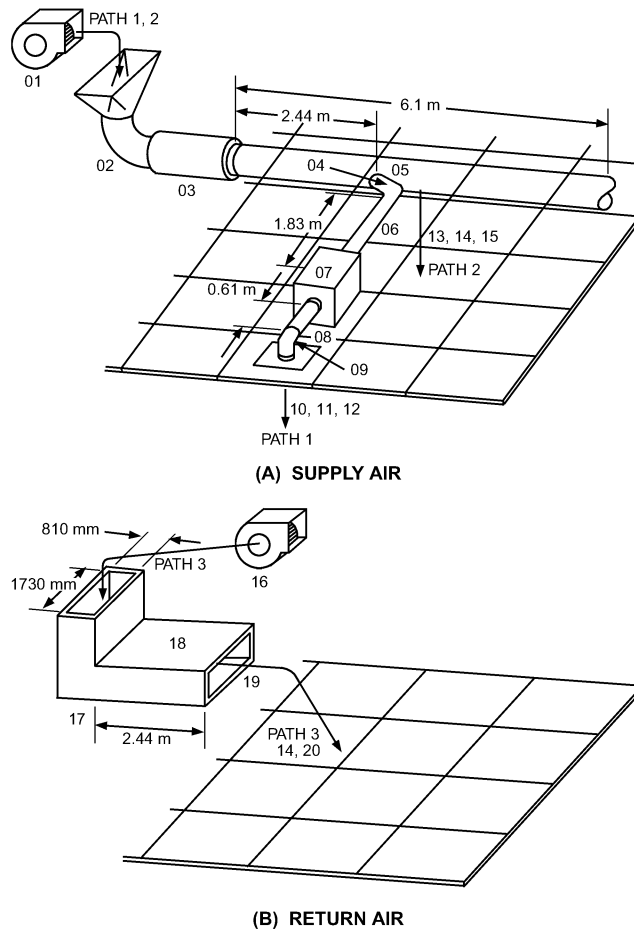
**Fig. 36 Sound Paths Layout for Example 8**

equipment room (MER) walls or external building elements to minimize breakout before the silencer.

- (c) Consider increasing the length of ductwork or introducing bends or a plenum to increase the sound attenuation. Care needs to be taken to ensure that the breakout noise path(s) are still acceptable where additional ductwork is introduced.
  - (d) Increase the sound transmission loss properties of building elements where this is the controlling noise path. This may be achieved by installing additional mass [e.g., thicker walls or filled concrete masonry units (CMUs)] or by introducing an air gap with a secondary layer (e.g., double glazing).
  - (e) Consider installing noise barriers around the external plant to minimize the direct line of sight between plant and critical spaces. The manufacturers' requirements for access and airflow around equipment must be carefully considered where noise barriers are used.
  - (f) If resultant noise levels are high enough to cause perceivable vibration, then major redesign and possibly use of supplemental vibration isolation for equipment and building systems are often required.
  - (g) Reference should also be made to this chapter's sections on Acoustical Design of HVAC Systems and Basic Acoustical Design Techniques.
10. Repeat steps 4 to 9 until the desired design goal is achieved. Involve the complete design team where major problems are found. Often, simple design changes to building architectural and equipment selection can eliminate potential problems once the problems are identified. Ensure that all valid noise-transmission paths are assessed.
  11. Repeat steps 3 through 10 for every room that is to be analyzed.
  12. Make sure that environmental noise radiated by outdoor equipment such as air-cooled chillers, exhaust fans, condensers, and cooling towers does not disturb adjacent properties or interfere with criteria established in step 1 or any applicable building or zoning noise ordinances.

**Example 8.** This example illustrates step 4 in the design process. Previous examples demonstrate how to calculate equipment- and air distribution system airflow-generated sound power levels and attenuation values. Here, the individual elements are combined to determine sound pressure levels associated with a specific HVAC system. Only a summary of tabulated results is listed rather than showing complete calculations for each element. Calculations for each element are strictly based on the methods in this chapter or manufacturers' data. Noise transmission via the roof structure has not been considered in this example.

Air is supplied to the HVAC system by the rooftop unit shown in Figure 36, with a supply and return layout as in Figure 37. The receiver room is directly below the unit. The room has the following dimensions: length = 6.1 m, width = 6.1 m, and height = 2.75 m. Assume that the roof penetrations for supply and return air ducts are well sealed and there are no other roof penetrations. In this example, it is assumed that



**Fig. 37 (A) Supply and (B) Return Air Layout for Example 8**

breakout noise (upstream of the supply air silencer) is negligible. The supply side of the rooftop unit is ducted to a VAV terminal control unit serving the room in question. Although these units can create both ductborne and radiated noise, only the ductborne noise has been considered in this example. A return air grille conducts air to a common ceiling return air plenum. The return air is then directed to the rooftop unit through a short rectangular return air duct.

The following three sound paths are to be examined. Note that in this example, neither noise transmission via the roof structure nor any other breakout noise upstream of the silencer has been considered. Those paths, plus VAV unit-radiated noise and other potential breakout noise paths, have been excluded from the analysis for simplification. In critical applications, each of those separate elements must also be considered.

- Path 1.** Fan airborne supply air sound that enters the room from the supply air system through the ceiling diffuser
- Path 2.** Fan airborne supply air sound that breaks out through the wall of the main supply air duct into the plenum space above the room
- Path 3.** Fan airborne return air sound that enters the room from the inlet of the return air duct

The tabulated calculations for each path follow, and are graphed in Figure 38:

Path Description	Path Sound Pressure Level, dB						
	63	125	250	500	1000	2000	4000 NC
1 Ducted supply air path	62	64	60	55	52	49	43 52
2 Breakout noise from 560 mm main duct	39	29	17	12	13	18	9 19
3 Return air path	64	57	53	47	34	31	25 44
Total $L_p$	66	65	60	56	52	49	43 52

Path 1: Ducted Supply Air

Element		Sound Power Attenuation, dB							Regenerated Sound Power, dB							Path Sound Power, dB						
ID	Description	63	125	250	500	1000	2000	4000	63	125	250	500	1000	2000	4000	63	125	250	500	1000	2000	4000
1	Supply air fan, 3.3 m <sup>3</sup> /s, 620 Pa static pressure (SP)	0	0	0	0	0	0	0	92	86	80	78	78	74	71	92	86	80	78	78	74	71
2	560 mm dia., 90° rad. unlined elbow	0	1	2	3	3	3	3	0	0	0	0	0	0	0	92	85	78	75	75	71	68
3	560 mm × 1.12 m long sound attenuator	4	7	19	31	38	38	27	68	79	69	60	59	59	55	88	82	69	60	59	59	55
4	560 mm dia., 2.44 m long unlined duct	0	0	0	0	0	0	0	0	0	0	0	0	0	0	88	82	69	60	59	59	55
5.2	250 mm dia. branch, 560 mm dia. main, branch path	8	8	8	8	8	8	8	0	0	0	0	0	0	0	80	74	61	52	51	51	47
6	250 mm dia., 1.83 m long unlined duct	0	0	0	0	0	0	0	0	0	0	0	0	0	0	80	74	61	52	51	51	47
7	VAV terminal	0	0	0	0	0	0	0	74	70	65	63	60	55	80	77	71	65	63	61	56	
8	250 mm dia., 600 mm long unlined duct	0	0	0	0	0	0	0	0	0	0	0	0	0	0	80	77	71	65	63	61	56
9	250 mm dia., 90° rad. unlined elbow	0	0	1	2	3	3	3	0	0	0	0	0	0	0	80	77	70	63	60	58	53
10	250 mm dia. diffuser, end reflection	14	8	4	1	0	0	0	0	0	0	0	0	0	0	66	69	66	62	60	58	53
11	380 × 380 mm rectangular diffuser	0	0	0	0	0	0	0	31	36	39	40	39	36	30	66	69	66	62	60	58	53
12	ASHRAE room correction: point source*	4	5	6	7	8	9	10	0	0	0	0	0	0	0	62	64	60	55	52	49	43

Path 2: Breakout Noise from 560 mm Main Duct

Element		Sound Power Attenuation, dB							Regenerated Sound Power, dB							Path Sound Power, dB						
ID	Description	63	125	250	500	1000	2000	4000	63	125	250	500	1000	2000	4000	63	125	250	500	1000	2000	4000
1	Supply air fan, 3.3 m <sup>3</sup> /s, 620 Pa SP	0	0	0	0	0	0	0	92	86	80	78	78	74	71	92	86	80	78	78	74	71
2	560 mm dia., 90° rad. unlined elbow	0	1	2	3	3	3	3	0	0	0	0	0	0	0	92	85	78	75	75	71	68
3	560 mm × 1.12 m long sound attenuator	4	7	19	31	38	38	27	68	79	69	60	59	59	55	88	82	69	60	59	59	55
4	560 mm dia., 2.4 m long unlined duct	0	0	0	0	0	0	0	0	0	0	0	0	0	0	88	82	69	60	59	59	55
5.1	250 mm dia. branch, 560 mm dia. main, main path	1	1	1	1	1	1	0	0	0	0	0	0	0	0	87	81	68	59	58	58	54
13	560 mm dia., 6 m long, 0.6 m duct breakout	35	37	35	28	20	10	13	0	0	0	0	0	0	0	52	44	34	32	38	48	42
14	600 × 1200 × 16 mm lay-in ceiling	13	15	17	19	25	30	33	0	0	0	0	0	0	0	39	29	17	13	13	18	9

Path 3: Return Air

Element		Sound Power Attenuation, dB							Regenerated Sound Power, dB							Path Sound Power, dB						
ID	Description	63	125	250	500	1000	2000	4000	63	125	250	500	1000	2000	4000	63	125	250	500	1000	2000	4000
16	Return air fan, 3.3 m <sup>3</sup> /s, 620 Pa SP	0	0	0	0	0	0	0	82	79	80	78	78	74	71	82	79	80	78	78	74	71
17	915 × 1830 mm, 90° mitered unlined elbow	1	5	8	4	3	3	3	0	0	0	0	0	0	0	81	74	72	74	75	71	68
18	915 × 1830 mm, 2.44 m long lined duct	0	1	2	8	16	10	10	0	0	0	0	0	0	0	81	73	70	66	59	61	58
19	915 × 1830 mm end reflection loss	4	1	0	0	0	0	0	0	0	0	0	0	0	0	77	72	70	66	59	61	58
14	600 × 1200 × 16 mm lay-in ceiling	13	15	17	19	25	30	33	0	0	0	0	0	0	0	64	57	53	47	34	31	25

\*Based on a location 1.5 m above floor at a receiver 1200 mm from source

Calculation Procedure

Analysis for each path begins at the rooftop unit and proceeds through the different system elements to the receiver room. The element numbers in the tables correspond to those in Figure 37. The source of each element calculation is listed in Table 44. Sound data for the rooftop unit (supply and return openings), VAV terminal, diffuser, and duct sound attenuator are manufacturers' data.

A spreadsheet was used to perform the calculations associated with this example. This type of calculation is often performed iteratively, as described in the preceding design procedure, but using a well-crafted spreadsheet increases the speed and accuracy of calculations.

Calculation tables for paths 1, 2, and 3 are organized with an element in each row. Three spectra (63 Hz to 4000 Hz) are shown for each element. The first and second spectra (sound power attenuation and regenerated sound power) are either calculated based on the equations and tables in this chapter or acquired from a manufacturer. It is important to note that sound power data and not sound pressure data must be used in these calculations.

The spreadsheet subtracts the sound attenuation spectrum, band by band, from the path sound power spectrum in the previous row. Then, the resultant sound power is logarithmically added per band to the element sound power. This calculation is performed for each element (row).

$$L_w = 10 \log(10^{L_{w1}/10} + 10^{L_{w2}/10}) \quad (33)$$

The last element in each path is either the ASHRAE room sound correction or the ceiling/plenum/room attenuations outlined in

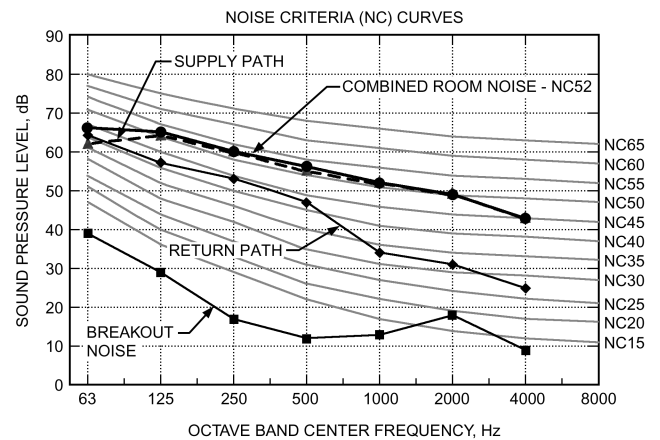


Fig. 38 NC Rating Calculated

Table 43, which is entered as an attenuation spectrum as it is subtracted directly from the final path sound power spectrum.

3. VIBRATION ISOLATION AND CONTROL

Mechanical vibration and vibration-induced noise are common sources of occupant complaints in modern buildings. Low-mass construction in buildings provides conditions that can result in vibration-related problems. Mandates for energy conservation have

**Table 44 Path Element Sound Calculation Reference**

ID	Description	Data Source Reference
01	Supply air fan, 3.3 m <sup>3</sup> /s, 620 Pa static pressure (SP)	Manufacturer's data
02	560 mm dia., 90° rad. unlined elbow	Attenuation: <a href="#">Table 23</a>
03	560 mm dia. 1.12 m long sound attenuator	Manufacturer's data
04	560 mm dia., 2.4 m long unlined duct	Attenuation: <a href="#">Table 16</a>
05.2	250 mm dia. branch, 560 mm dia. main, branch path	Attenuation: <a href="#">Table 26</a>
05.1	250 mm dia. branch, 560 mm dia. main, main path	Attenuation: <a href="#">Table 26</a>
06	250 mm dia., 1.83 m long unlined duct	Attenuation: <a href="#">Table 16</a>
07	VAV terminal	Manufacturer's data
08	250 mm dia., 600 m long unlined duct	Attenuation: <a href="#">Table 16</a>
09	250 mm dia., 90° rad. unlined elbow	Attenuation: <a href="#">Table 23</a>
10	250 mm dia. diffuser, end reflection	Attenuation: <a href="#">Table 28</a>
11	380 × 380 mm rectangular diffuser	Manufacturer's data
12	ASHRAE room correction: point source	Equation (26) or (27), <a href="#">Tables 35 and 36</a>
13	560 mm dia., 6 m long, 0.6 mm duct breakout	Attenuation: Equation (20), <a href="#">Table 30</a>
14	600 × 1200 × 16 mm lay-in ceiling	Attenuation: <a href="#">Table 32</a>
16	Return air fan, 3.3 m <sup>3</sup> /s, 620 Pa SP	Manufacturer's data
17	915 × 1830 mm, 90° mitered unlined elbow	Attenuation: <a href="#">Tables 22 and 24</a>
18	915 × 1830 mm, 2.44 m long lined duct	Attenuation: <a href="#">Table 18</a> ; assume 0 dB at 63 Hz
19	915 × 1830 mm end reflection loss	Attenuation: <a href="#">Table 27</a> , $D = 1.1$ m
20	ASHRAE Room Correction	Point source: Equation (26) or (27), <a href="#">Tables 35 and 36</a>

resulted in many buildings being designed with variable air volume systems with variable-speed equipment. As rotating equipment spins slower, its forcing frequency approaches the structure's resonant frequency, which can amplify vibration-induced noise and generate vibration at the structure's resonant frequency. Mechanical equipment is often located in penthouses or on the roof, where structures are typically the most susceptible to inducing vibration-related problems. Mechanical equipment rooms are typically located on intermediate level floors, close to the occupied areas they serve.

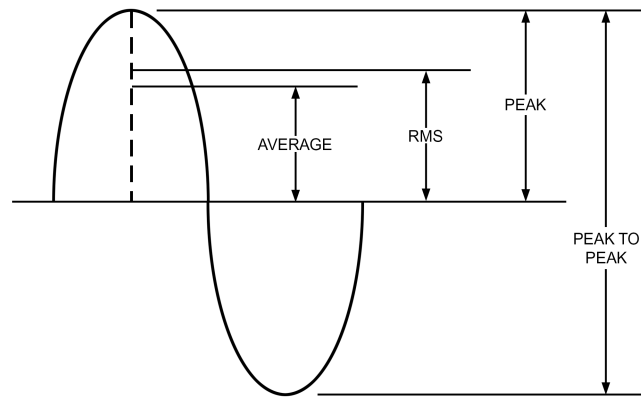
Occupant complaints associated with building vibration typically take one or more of three forms:

- The level of vibration perceived by building occupants is of sufficient magnitude to cause annoyance, concern, or alarm
- Vibration energy from mechanical equipment, which is transmitted to the building structure, is transmitted to various parts of the building and then is radiated as structureborne noise
- Vibration in a building may interfere with proper operation of sensitive equipment or instrumentation

The following sections present basic information to properly select and specify vibration isolators and to analyze and correct field vibration problems.

### 3.1 VIBRATION MEASUREMENT

Understanding the vibratory characteristics of HVAC equipment can be of great use in diagnosing the sources of both tonal and broadband sound or vibration. The advent of low-cost vibration measurement systems has made detailed vibration evaluation much more practical and commonplace. At the same time, it is important to bear in mind that vibration measurement is a specialty that is best done by, or at least overseen by, a specialist.

**Fig. 39 Vibration Amplitude Terminology**

Components of a vibration measurement system include the following:

- A **transducer**, which outputs an electrical signal proportional to its vibration level. The most common transducer, called an **accelerometer**, measures vibratory acceleration at its point of attachment to the structure. As explained in Chapter 8 of the 2013 *ASHRAE Handbook—Fundamentals*, accelerometers are the preferred transducers in most situations. They are compact, relatively rugged, capable of a wide measurement range in terms of both vibration level and frequency, and are easy to install (depending on the frequency range of interest).
- A **preamplifier** for the transducer, which amplifies the signal to a level suitable to the data acquisition system and for the signal conditioner. Depending on the transducer and analyzer type, a preamplifier may not be needed.
- An **analyzer**, or **vibration meter**, with a display showing the vibration level. The most basic analyzers measure the overall vibration amplitude across a specified frequency range, which does not by itself yield enough analytical detail for troubleshooting. Many are capable of measuring vibration as a function of frequency, with constant frequency spacing. These so-called “narrowband,” or fast Fourier transform (FFT), analyzers display the vibration frequency spectrum with a very high degree of resolution. Alternative analyzers of the constant-percentage bandwidth type display the vibration spectrum across a number of frequency bands, the widths of which increase proportionally to the center frequency of each band. These often display vibration at octave, 1/3rd octave, or 1/12th octave frequencies.

Any steady-state vibration, such as that generated by a machine operating at a fixed speed, can be expressed as acceleration, velocity, or displacement. By integrating the acceleration signal, it is possible to convert each of these quantities to the others. Integrating the velocity signal yields the displacement. Note that many transducers cannot measure vibration below a minimum frequency associated with the transducer. The practical implication of that limitation is that, in many cases, measured acceleration cannot be fully converted to displacement, and can never be used to quantify static displacement. For that reason, where very-low-frequency vibration measurements are required, special transducers, such as displacement probes, are needed.

Vibration measurements must specify how the amplitudes are expressed. These can be either peak (maximum level), peak-to-peak (the range between minima and maxima), or rms (root mean square). For a sine wave, the peak-to-peak value is twice the peak, and the rms is the peak divided by the square root of two ([Figure 39](#)).

Several factors must be considered when making vibration measurements. One of these is transducer attachment to the vibrating

object. An extremely rigid attachment method, such as dental cement, or a screwed connection with oil between the surfaces, is required for accurate measurement at very high frequency (about 5 kHz). Epoxies or other high-quality glues tend to be somewhat more limited but are acceptable in nearly all situations up to 1 kHz. Using magnetic attachments, though convenient and fully acceptable in many cases, limits the upper frequency range of accurate data (typically about 1 kHz). Another common but frequency-limited method of attachment is wax, typically reliable up to 80 Hz. In any case, it is essential to validate that the attachment used in a given application is capable of measuring vibration to the needed degree of accuracy. It is best to contact transducer/analyzer manufacturers to ensure frequency limits can be accurately measured.

Several data processing factors must be considered for narrow-band (FFT) measurement. These significantly affect the quality of spectral data and how they are interpreted. Among them are the window type, number of averages, window overlap, frequency resolution, and sampling frequency. Again, guidance from a specialist should be sought when establishing these factors for a given measurement.

Typical applications of vibration measurement include

- Comparison of overall vibration levels (the total across a defined frequency range) with general guidelines representing typical levels to be expected from various classes of machinery. This most basic measurement is often used in connection with routine machinery maintenance or monitoring.
- Comparison of vibration spectral values with either equipment specifications, building specifications, or general guidelines. These more complete data, sometimes defined in terms of octave or 1/3 octave frequencies, provide more detailed guidance for machinery health monitoring, equipment qualification, or building certification.
- Comparison of vibration spectral values above and below vibration isolators, such as pads or springs, to determine if they are providing the anticipated vibration reduction. Note that, as explained in Chapter 8 of the 2013 *ASHRAE Handbook—Fundamentals*, interpretation of the results of these measurements may not be straightforward, especially for multiple-degree-of-freedom systems.
- Using a narrowband measurement system, determination of exact frequencies of tonal vibration sources. This information can be critical in identifying the specific machine or vibration component responsible for excessive vibration or noise. In some cases, a high degree of measurement resolution is required to separate closely spaced tones. For example, in 60 Hz applications, twice the motor or compressor running speeds are typically close to 118 Hz, while twice the electrical line frequency is 120 Hz. Clearly, while the difference between these frequencies is inaudible, knowing which source is responsible for a problem is essential to developing a solution.

Finally, it is noted that many specialized applications of vibration and dynamic measurement require advanced data acquisition equipment, data analysis software, and associated training. Examples are

- Transient vibration measurement
- Impact/frequency response measurement
- Modal testing
- Rotating equipment balancing
- Direct displacement measurement (e.g., rotating shaft orbit analysis)

### 3.2 EQUIPMENT VIBRATION

Any vibrating, reciprocating, or rotating equipment should be mounted such that it does not transmit significant levels of vibration into the surrounding or supporting structure. Vibrations transmitted

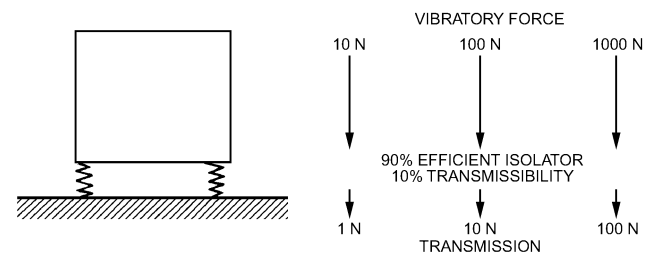


Fig. 40 Transmission to Structure Varies as Function of Magnitude of Vibration Force

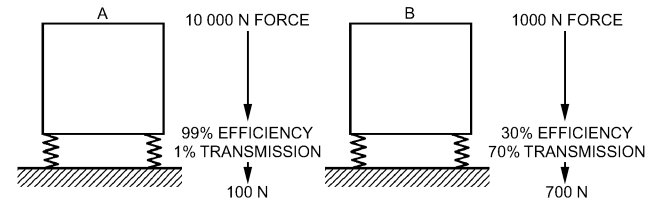


Fig. 41 Interrelationship of Equipment Vibration, Isolation Efficiency, and Transmission

via machine mounts or attached piping, ductwork, or electrical connections can result in vibrating walls, floors, and/or ceilings, which in turn radiate sound and/or vibration. Hence, it is important to provide vibration isolation for all attachments to a vibrating machine, including structural mounts and the connections to piping, ductwork, and the electrical system. It is also important to mitigate residual vibrations in attached piping and ductwork, even when equipment is properly isolated.

Vibration can be isolated or reduced to a fraction of the original force with resilient mounts between the equipment and the supporting structure, provided that the supporting structure has sufficient stiffness and mass. Isolation transmissibility is the percentage of the vibratory force transmitted to the support. **Isolation efficiency** is the percentage of vibratory force *not* transmitted to the support structure. Figure 40 shows that 90% efficiency results in 10% of the vibration force being transmitted. In this case, the magnitude of the transmission to the building is a function of the magnitude of the vibration force. Figure 41 shows the effect of different efficiency levels. See Equation (48) in Chapter 8 of the 2013 *ASHRAE Handbook—Fundamentals*, for a more detailed explanation of isolation transmissibility and efficiency.

Transmissibility and isolation efficiency are a function of the frequency of the transmitted (disturbing) force, and the natural frequency of the isolation system. The transmissibility is given by

$$T = \left| \frac{1}{1 - \left(\frac{f_d}{f_n}\right)^2} \right| \times 100\% \quad (34)$$

where  $f_d$  is the frequency of the disturbing force and  $f_n$  is the natural frequency of the isolator. The efficiency is given by

$$E = 100\% - T \quad (35)$$

where  $T$  is the transmissibility given by Equation (34).

### 3.3 VIBRATION CRITERIA

For the HVAC designer, vibration criteria are specified relative to three areas: (1) human response to vibration, (2) vibration levels associated with potential disruption to the use of sensitive equipment in a building, and (3) vibration severity of an operating machine. Figure 42 and Table 45 present recommended acceptable criteria for

**Table 45 Human Comfort and Equipment Vibration Criteria (in rms velocity) from Continuous Vibration**

Human Comfort <sup>a</sup>	Time of Day	8 to 80 Hz Curve, <sup>a,b</sup> mm/s rms
Workshops	All	0.813
Office areas	All <sup>c</sup>	0.406
Residential (good environmental standards)	0700-2200 <sup>c</sup>	0.203
	2200-0700 <sup>c</sup>	0.144
Hospital operating rooms and critical work areas	All	0.102
Equipment Requirements (For critical, highly sensitive situations, consult manufacturer's requirements)		Curve <sup>c</sup>
Adequate for computer equipment, probe test equipment, and microscopes less than 40×		0.203
Bench microscopes up to 100× magnification; laboratory robots		0.102
Bench microscopes up to 400× magnification; optical and other precision balances; coordinate measuring machines; metrology laboratories; optical comparators; microelectronics manufacturing equipment; proximity and projection aligners, etc.		0.051
Microsurgery, eye surgery, neurosurgery; bench microscopes at magnification greater than 400×; optical equipment on isolation tables; microelectronic manufacturing equipment, such as inspection and lithography equipment (including steppers) to 3 mm line widths <sup>d</sup>		0.025
Electron microscopes up to 30 000× magnification; microtomes; magnetic resonance imagers; microelectronics manufacturing equipment, such as lithography and inspection equipment to 1 mm detail size <sup>d</sup>		0.013
Electron microscopes at magnification greater than 30 000×; mass spectrometers; cell implant equipment; microelectronics manufacturing equipment, such as aligners, steppers, and other critical equipment for photolithography with line widths of 1/2 μm; includes electron beam systems <sup>d</sup>		0.0064
Unisolated laser and optical research systems; microelectronics manufacturing equipment, such as aligners, steppers, and other critical equipment for photolithography with line widths of 1/4 μm; includes electron beam systems <sup>d</sup>		0.0032

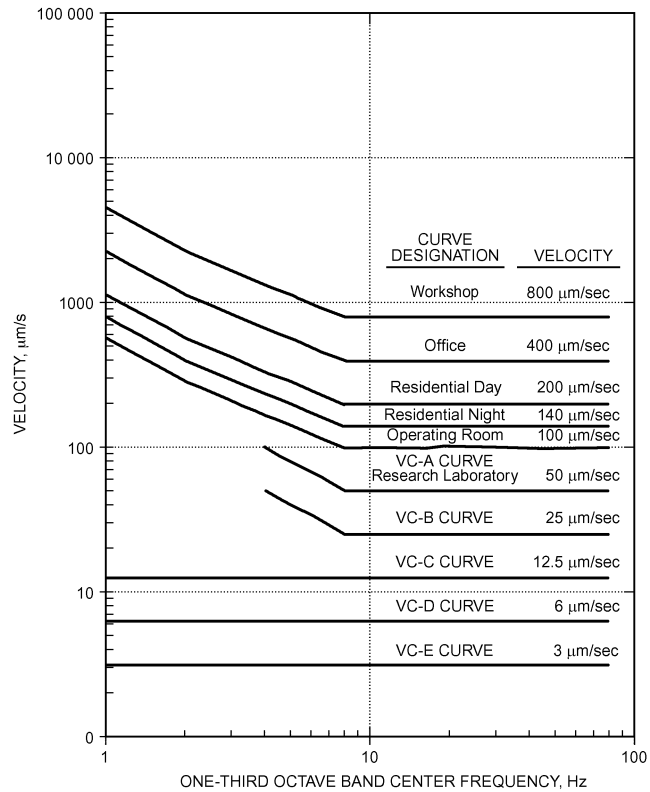
<sup>a</sup>Any acoustical noise caused by vibrating walls is not considered.  
<sup>b</sup>See Figure 41 for corresponding curves.  
<sup>c</sup>In areas where individuals are sensitive to vibration, use Residential Day curve.  
<sup>d</sup>Classes of microelectronics manufacturing equipment.

**Table 46 Maximum Allowable rms Velocity Levels**

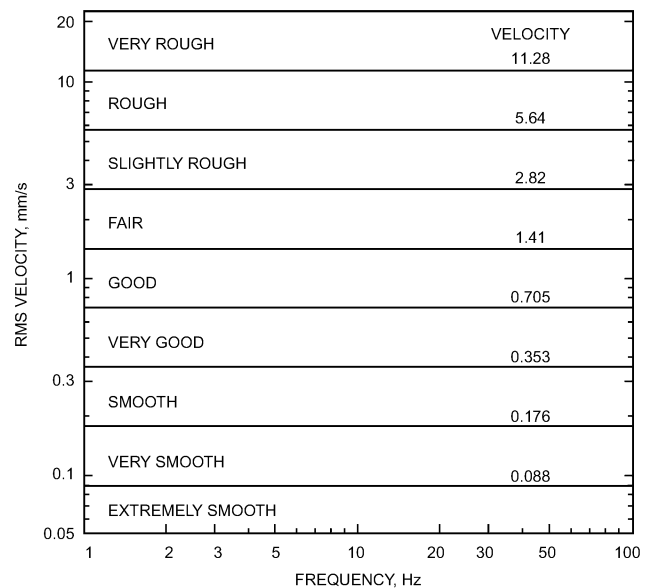
Equipment	Allowable rms Velocity, mm/s
Pumps	3.3
Centrifugal compressors	3.3
Fans (vent sets, centrifugal, axial)	2.3

vibration in a building structure (IEST 2007; Murray et al. 1997). The vibration values in Figure 42 are measured in one-third octave bands using vibration transducers (usually accelerometers) placed on the building structure near vibrating equipment or in areas containing occupants or sensitive equipment. Occupant vibration criteria are based on guidelines recommended in ANSI Standard S2.71-1983 (R2006) and ISO Standard 2631-2. For sensitive equipment, acceptable vibration values specified by equipment manufacturers should be used. If none are available, then criteria from IEST (2007), as reflected in Figure 42 and Table 45, can be used.

If acceptable vibration values are not available from equipment manufacturers, the values specified in Figure 43 can be used. This figure gives recommended equipment vibration severity ratings based on measured rms velocity values (IRD 1988). The vibration values in Figure 43 are measured by vibration transducers (usually



**Fig. 42 Building Vibration Criteria for Vibration Measured on Building Structure**



**Fig. 43 Equipment Vibration Severity Rating for Vibration Measured on Equipment Structure or Bearing Caps**

accelerometers) mounted directly on equipment, equipment structures, or bearing caps. Vibration levels measured on equipment and components can be affected by equipment unbalance, misalignment of equipment components, and resonance interaction between a

vibrating piece of equipment and the floor on which it is placed. If a piece of equipment is aligned and balanced within acceptable tolerances and excessive vibration levels still exist, the equipment and installation should be checked for possible resonant conditions Table 46 gives maximum allowable rms velocity levels for selected pieces of equipment.

Vibration levels measured on equipment structures should be in or below the “good” region in Figure 43. Machine vibration levels in the “fair” or “slightly rough” regions may indicate potential problems requiring maintenance. Machines with vibration levels in these regions should be monitored to ensure problems do not arise. Machine vibration levels in the “rough” and “very rough” regions

indicate a potentially serious problem; immediate action should be taken to identify and correct the problem.

### 3.4 SPECIFICATION OF VIBRATION ISOLATORS

Vibration isolators must be selected not only to provide required isolation efficiency but also to ensure that the natural frequency of the isolated system is not close to the natural frequency of the floor. If vibration isolators are not correctly selected, the isolator may actually amplify the force transmitted. Floor spans, equipment operating speeds, equipment power, damping, and other factors are considered in Table 47.

Table 47 Selection Guide for Vibration Isolation

Equipment Type	Shaft Power kW and Other	RPM	Equipment Location (Notes for Table 47, Item 1)												Reference Notes	
			Slab on Grade		Floor Span											
					Up to 6 m			6 to 9 m			9 to 12 m					
			Base Type	Isolator Type	Min. Defl., mm	Base Type	Isolator Type	Min. Defl., mm	Base Type	Isolator Type	Min. Defl., mm	Base Type	Isolator Type	Min. Defl., mm		
<b>Refrigeration Machines and Chillers</b>																
Water-cooled reciprocating	All	All	A	2	6.4	A	4	19	A	4	38	A	4	64	2,3,12	
Water-cooled centrifugal, scroll	All	All	A	1	6.4	A	4	19	A	4	38	A	4	38	2,3,4,8,12	
Water-cooled screw Absorption	All	All	A	4	25	A	4	38	A	4	64	A	4	64	2,3,4,12	
Air-cooled recip., scroll	All	All	A	1	6.4	A	4	38	A	4	38	A	4	64	2,4,5,12	
Air-cooled screw	All	All	A	4	25	A	4	38	B	4	64	B	4	64	2,4,5,8,12	
<b>Air Compressors and Vacuum Pumps</b>																
Tank-mounted horiz.	≤7.5	All	A	3	19	A	3	19	A	3	38	A	3	38	3,15	
	≥7.5	All	C	3	19	C	3	19	C	3	38	C	3	38	3,15	
Tank-mounted vert.	All	All	C	3	19	C	3	19	C	3	38	C	3	38	3,15	
Base-mounted	All	All	C	3	19	C	3	19	C	3	38	C	3	38	3,14,15	
Large reciprocating	All	All	C	3	19	C	3	19	C	3	38	C	3	38	3,14,15	
<b>Pumps</b>																
Close-coupled	≤5.6	All	B	2	6.4	C	3	19	C	3	19	C	3	19	16	
	≥5.6	All	C	3	19	C	3	19	C	3	38	C	3	38	16	
Large inline	3.7 to 19	All	A	3	19	A	3	38	A	3	38	A	3	38		
	≥19	All	A	3	38	A	3	38	A	3	38	A	3	64		
End suction and split case	≤30	All	C	3	19	C	3	19	C	3	38	C	3	38	16	
	30 to 93	All	C	3	19	C	3	19	C	3	38	C	3	64	10,16	
Packaged pump systems	≥93	All	C	3	19	C	3	38	C	3	64	C	3	89	10,16	
	All	All	A	3	19	A	3	19	A	3	38	C	3	64		
<b>Cooling Towers</b>																
All	Up to 300	A	1	6.4	A	4	89	A	4	89	A	4	89	5,8,18		
		A	1	6.4	A	4	64	A	4	64	A	4	64	5,18		
		A	1	6.4	A	4	19	A	4	19	A	4	38	5,18		
<b>Boilers</b>																
Fire-tube	All	All	A	1	6.4	B	4	19	B	4	38	B	4	64	4	
Water-tube, copper fin	All	All	A	1	3	A	1	3	A	1	3	B	4	6.4		
<b>Axial Fans, Plenum Fans, Cabinet Fans, Fan Sections, Centrifugal Inline Fans</b>																
Up to 560 mm diameter	All	All	A	2	6.4	A	3	19	A	3	19	C	3	19	4,9	
610 mm diameter and up	≤500 Pa SP	Up to 300	B	3	64	C	3	89	C	3	89	C	3	89	9,8	
		300 to 500	B	3	19	B	3	38	C	3	64	C	3	64	9,8	
		501 and up	B	3	19	B	3	38	B	3	38	B	3	38	9,8	
		≥501 Pa SP	Up to 300	C	3	64	C	3	89	C	3	89	C	3	89	3,8,9
		300 to 500	C	3	38	C	3	38	C	3	64	C	3	64	3,8,9	
		501 and up	C	3	19	C	3	38	C	3	38	C	3	64	3,8,9	
<b>Centrifugal Fans</b>																
Up to 560 mm diameter	All	All	B	2	6.4	B	3	19	B	3	19	B	3	38	9,19	
610 mm diameter and up	≤30	Up to 300	B	3	64	B	3	89	B	3	89	B	3	89	8,19	
		300 to 500	B	3	38	B	3	38	B	3	64	B	3	64	8,19	
		501 and up	B	3	19	B	3	19	B	3	19	B	3	38	8,19	
		≥37	Up to 300	C	3	64	C	3	89	C	3	89	C	3	89	2,3,8,9,19
		300 to 500	C	3	38	C	3	38	C	3	64	C	3	64	2,3,8,9,19	
		501 and up	C	3	25.4	C	3	38	C	3	38	C	3	64	2,3,8,9,19	

Table 47 Selection Guide for Vibration Isolation (Continued)

Equipment Type	Shaft Power kW and Other	RPM	Equipment Location (Notes for Table 47, Item 1)												Reference Notes
			Slab on Grade		Floor Span										
					Up to 6 m		6 to 9 m		9 to 12 m						
			Base Type	Min. Defl., mm	Base Type	Min. Defl., mm	Base Type	Min. Defl., mm	Base Type	Min. Defl., mm	Base Type	Min. Defl., mm			
<b>Propeller Fans</b>															
Wall-mounted	All	All	A	1	6.4	A	1	6.4	A	1	6.4	A	1	6.4	
Roof-mounted	All	All	A	1	6.4	A	1	6.4	B	4	38	D	4	38	
<b>Heat Pumps, Fan-Coils, Computer Room Units</b>															
	All	All	A	3	19	A	3	19	A	3	19	A/D	3	38	
<b>Condensing Units</b>															
	All	All	A	1	6.4	A	4	19	A	4	38	A/D	4	38	
<b>Packaged AH, AC, H and V Units</b>															
All	7.5	All	A	3	19	A	3	19	A	3	19	A	3	19	19
	7.5 to 11	Up to 300	A	3	19	A	3	89	A	3	89	C	3	89	2,4,8,19
	≤ 1kPa SP	301 to 500	A	3	19	A	3	64	A	3	64	A	3	64	4,19
		501 and up	A	3	19	A	3	38	A	3	38	A	3	38	4,19
	>11,	Up to 300	B	3	19	C	3	89	C	3	89	C	3	89	2,3,4,8,9
	> 1kPa SP	301 to 500	B	3	19	C	3	38	C	3	64	C	3	64	2,3,4,9
		501 and up	B	3	19	C	3	38	C	3	38	C	3	64	2,3,4,9
<b>Packaged Rooftop Equipment</b>															
	All	All	A/D	1	6.4	D	3	19	See Reference Note 17				5,6,8,17		
<b>Ducted Rotating Equipment</b>															
Small fans, fan-powered boxes	≤300 L/s	All	A	3	12.7	A	3	12.7	A	3	12.7	A	3	12.7	7
	≥301 L/s	All	A	3	19	A	3	19	A	3	19	A	3	19	7
<b>Engine-Driven Generators</b>															
	All	All	A	3	19	C	3	38	C	3	64	C	3	89	2,3,4

Piping and Ducts (See sections on Isolating Vibration and Noise in Piping Systems and Isolating Duct Vibration for isolator selection.)

**Base Types:**

- A. No base, isolators attached directly to equipment (Note 28)
- B. Structural steel rails or base (Notes 29 and 30)
- C. Concrete inertia base (Note 30)
- D. Curb-mounted base (Note 31)

**Isolator Types:**

- 1. Pad, rubber, or glass fiber (Notes 20 and 21)
- 2. Rubber floor isolator or hanger (Notes 20 and 25)
- 3. Spring floor isolator or hanger (Notes 22, 23, and 26)
- 4. Restrained spring isolator (Notes 22 and 24)
- 5. Thrust restraint (Note 27)
- 6. Air spring (Note 25)

**Notes for Table 47: Selection Guide for Vibration Isolation**

These notes are keyed to the column titled *Reference Notes* in Table 47 and to other reference numbers throughout the table. Although the guide is conservative, cases may arise where vibration transmission to the building is still excessive. If the problem persists after all short circuits have been eliminated, it can almost always be corrected by altering the support path (e.g., from ceiling to floor), increasing isolator deflection, using low-frequency air springs, changing operating speed, improving rotating component balancing, or, as a last resort, changing floor frequency by stiffening or adding more mass. Assistance from a qualified vibration consultant can be very useful in resolving these problems.

**Note 1.** Isolator deflections shown are based on a reasonably expected floor stiffness according to floor span and class of equipment. Certain spaces may dictate higher levels of isolation. For example, bar joist roofs may require a static deflection of 38 mm over factories, but 64 mm over commercial office buildings.

**Note 2.** For large equipment capable of generating substantial vibratory forces and structureborne noise, increase isolator deflection, if necessary, so isolator stiffness is less than one-tenth the stiffness of the supporting structure, as defined by the deflection due to load at the equipment support.

**Note 3.** For noisy equipment adjoining or near noise-sensitive areas, see the section on Mechanical Equipment Room Sound Isolation.

**Note 4.** Certain designs cannot be installed directly on individual isolators (type A), and the equipment manufacturer or a vibration specialist should be consulted on the need for supplemental support (base type).

**Note 5.** Wind load conditions must be considered. Restraint can be achieved with restrained spring isolators (type 4), supplemental bracing, snubbers, or limit stops. Also see Chapter 55.

**Note 6.** Certain types of equipment require a curb-mounted base (type D). Airborne noise must be considered.

**Note 7.** See section on Resilient Pipe Hangers and Supports for hanger locations adjoining equipment and in equipment rooms.

**Note 8.** To avoid isolator resonance problems, select isolator deflection so that resonance frequency is 40% or less of the lowest normal operating speed of equipment (see Chapter 8 in the 2013 ASHRAE Handbook—

*Fundamentals*). Some equipment, such as variable-frequency drives, and high-speed equipment, such as screw chillers and vaneaxial fans, contain very-high-frequency vibration. This equipment creates new technical challenges in the isolation of high-frequency noise and vibration from a building's structure. Structural resonances both internal and external to the isolators can significantly degrade their performance at high frequencies. Unfortunately, at present no test standard exists for measuring the high-frequency dynamic properties of isolators, and commercially available products are not tested to determine their effectiveness for high frequencies. To reduce the chance of high-frequency vibration transmission, add a minimum 20 mm thick elastomeric pad (type 1, Note 20) to the base plate of spring isolators (type 3, Note 22, 23, 24). For some sensitive locations, air springs (Note 25) may be required. If equipment is located near extremely noise-sensitive areas, follow the recommendations of an acoustical consultant.

**Note 9.** To limit undesirable movement, thrust restraints (type 5) are required for all ceiling-suspended and floor-mounted units operating at 500 Pa or more total static pressure.

**Note 10.** Pumps over 55 kW may need extra mass and restraints.

**Note 11.** See text for full discussion.

**Isolation for Specific Equipment**

**Note 12. Refrigeration Machines:** Large centrifugal, screw, and reciprocating refrigeration machines may generate very high noise levels; special attention is required when such equipment is installed in upper-story locations or near noise-sensitive areas. If equipment is located near extremely noise-sensitive areas, follow the recommendations of an acoustical consultant.

**Note 13. Compressors:** The two basic reciprocating compressors are (1) single- and double-cylinder vertical, horizontal or L-head, which are usually air compressors; and (2) Y, W, and multihead or multicylinder air and refrigeration compressors. Single- and double-cylinder compressors generate high vibratory forces requiring large inertia bases (type C) and are generally not suitable for upper-story locations. If this equipment

**Notes for Table 47: Selection Guide for Vibration Isolation (Continued)**

must be installed in an upper-story location or at-grade location near noise-sensitive areas, the expected maximum unbalanced force data must be obtained from the equipment manufacturer and a vibration specialist consulted for design of the isolation system.

**Note 14. Compressors:** When using Y, W, and multihead and multicylinder compressors, obtain the magnitude of unbalanced forces from the equipment manufacturer so the need for an inertia base can be evaluated.

**Note 15. Compressors:** Base-mounted compressors through 4 kW and horizontal tank-type air compressors through 8 kW can be installed directly on spring isolators (type 3) with structural bases (type B) if required, and compressors 10 to 75 kW on spring isolators (type 3) with inertia bases (type C) with a mass 1 to 2 times the compressor mass.

**Note 16. Pumps:** Concrete inertia bases (type C) are preferred for all flexible-coupled pumps and are desirable for most close-coupled pumps, although steel bases (type B) can be used. Close-coupled pumps should not be installed directly on individual isolators (type A) because the impeller usually overhangs the motor support base, causing the rear mounting to be in tension. The primary requirements for type C bases are strength and shape to accommodate base elbow supports. Mass is not usually a factor, except for pumps over 55 kW, where extra mass helps limit excess movement due to starting torque and forces. Concrete bases (type C) should be designed for a thickness of one-tenth the longest dimension with minimum thickness as follows: (1) for up to 20 kW, 150 mm; (2) for 30 to 55 kW, 200 mm; and (3) for 75 kW and up, 300 mm.

Pumps over 55 kW and multistage pumps may exhibit excessive motion at start-up ("heaving"); supplemental restraining devices can be installed if necessary. Pumps over 90 kW may generate high starting forces; consult a vibration specialist.

**Note 17. Packaged Rooftop Air-Conditioning Equipment:** This equipment is usually installed on low-mass structures that are susceptible to sound and vibration transmission problems. The noise problems are compounded further by curb-mounted equipment, which requires large roof openings for supply and return air.

The table shows type D vibration isolator selections for all spans up to 6 m, but extreme care must be taken for equipment located on spans of over 6 m, especially if construction is open web joists or thin, low-mass slabs. The recommended procedure is to determine the additional deflection caused by equipment in the roof. If additional roof

deflection is 6 mm or less, the isolator should be selected for up to 10 times the additional roof deflection. If additional roof deflection is over 6 mm, supplemental roof stiffening should be installed to bring the roof deflection down below 6 mm, or the unit should be relocated to a stiffer roof position.

For mechanical units capable of generating high noise levels, mount the unit on a platform above the roof deck to provide an air gap (buffer zone) and locate the unit away from the associated roof penetration to allow acoustical treatment of ducts before they enter the building.

Some rooftop equipment has compressors, fans, and other equipment isolated internally. This isolation is not always reliable because of internal short-circuiting, inadequate static deflection, or panel resonances. It is recommended that rooftop equipment over 135 kg be isolated externally, as if internal isolation was not used.

**Note 18. Cooling Towers:** These are normally isolated with restrained spring isolators (type 4) directly under the tower or tower dunnage. High-deflection isolators proposed for use directly under the motor-fan assembly must be used with extreme caution to ensure stability and safety under all weather conditions. See Note 5.

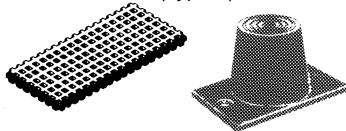
**Note 19. Fans and Air-Handling Equipment:** Consider the following in selecting isolation systems for fans and air-handling equipment:

1. Fans with wheel diameters of 560 mm and less and all fans operating at speeds up to 300 rpm do not generate large vibratory forces. For fans operating under 300 rpm, select isolator deflection so the isolator natural frequency is 40% or less than the fan speed. For example, for a fan operating at 275 rpm,  $0.4 \times 275 = 110$  rpm. Therefore, an isolator natural frequency of 110 rpm or lower is required. This can be accomplished with a 75 mm deflection isolator (type 3).
2. Flexible duct connectors should be installed at the intake and discharge of all fans and air-handling equipment to reduce vibration transmission to air duct structures.
3. Inertia bases (type C) are recommended for all class 2 and 3 fans and air-handling equipment because extra mass allows the use of stiffer springs, which limit heaving movements.
4. Thrust restraints (type 5) that incorporate the same deflection as isolators should be used for all fan heads, all suspended fans, and all base-mounted and suspended air-handling equipment operating at 500 Pa or more total static pressure. Restraint movement adjustment must be made under normal operational static pressures.

**Vibration Isolators: Materials, Types, and Configurations**

Notes 20 through 32 include figures to assist in evaluating commercially available isolators for HVAC equipment. The isolator selected for a particular application depends on the required deflection, life, cost, and compatibility with associated structures.

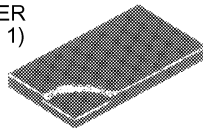
**RUBBER PADS (Type 1)**



**RUBBER MOUNTS (Type 2)**

**Note 20.** Rubber isolators are available in pad (type 1) and molded (type 2) configurations. Pads are used in single or multiple layers. Molded isolators come in a range of 30 to 70 durometer (a measure of stiffness). Material in excess of 70 durometer is usually ineffective because durometers are not a measure of stiffness of an isolator. Isolators are designed for up to 13 mm deflection, but are used where 8 mm or less deflection is required. Solid rubber and composite fabric and rubber pads are also available. They provide high load capacities with small deflection and are used as noise barriers under columns and for pipe supports. These pad types work well only when they are properly loaded and the mass load is evenly distributed over the entire pad surface. Metal loading plates can be used for this purpose.

**GLASS FIBER PADS (Type 1)**



**Note 21.** Glass fiber with elastic coating (type 1). This type of isolation pad is precompressed molded fiberglass pads individually coated with a flexible, moisture-impervious elastomeric membrane. Natural frequency of fiberglass vibration isolators should be essentially constant for the operating load range of the supported equipment. Mass load is evenly distributed over the entire pad surface. Metal loading plates can be used for this purpose.

**SPRING ISOLATOR (Type 3)**

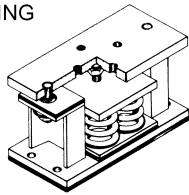


**Note 22.** Steel springs are the most popular and versatile isolators for HVAC applications because they are available for almost any deflection and have a virtually unlimited life. Spring isolators may have a rubber acoustical barrier to reduce transmission of high-frequency vibration and noise that can migrate down the steel spring coil. They should be corrosion protected if installed outdoors or in a corrosive environment. The basic types include the following:

**Note 23.** *Open spring isolators* (type 3) consist of top and bottom load plates with adjustment bolts for leveling equipment. Springs should be designed with a horizontal stiffness of at least 80% of the vertical stiffness ( $k_x/k_y$ ) to ensure stability. Similarly, the springs should have a minimum ratio of 0.8 for the diameter divided by the deflected spring height.

Notes for Table 47: Vibration Isolators: Materials, Types, and Configurations (Continued)

RESTRAINED SPRING ISOLATOR (Type 4)



**Note 24.** *Restrained spring isolators* (type 4) have hold-down bolts to limit vertical as well as horizontal movement. They are used with (a) equipment with large variations in mass (e.g., boilers, chillers, cooling towers) to restrict movement and prevent strain on piping when water is removed, (b) outdoor equipment, such as condensing units and cooling towers, to prevent excessive movement due to wind loads, and (c) with any equipment subject to seismic forces. Spring criteria should be the same as open spring isolators, and snubbers should have adequate clearance so that they are activated only when a temporary restraint is needed. See Chapter 55 for typical snubber types.

*Closed mounts or housed spring isolators* consist of two telescoping housings separated by a resilient material. These provide lateral snubbing and some vertical damping of equipment movement, but do not limit the vertical movement. Additional vertical snubbers must be used where vertical travel must be limited (see Chapter 55). Care should be taken in selection and installation to minimize binding and short circuiting.

AIR SPRINGS (Type 6)

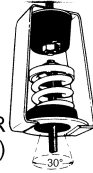


**Note 25.** Air springs (type 6) can be designed for any frequency, but are economical only in applications with natural frequencies of 1.33 Hz or less (150 mm or greater deflection). They do not transmit high-frequency noise and are often used to replace high-deflection springs on problem jobs (e.g., large transformers on upper-floor installations). A constant air supply (an air compressor with an air dryer) and leveling valves are typically required.

RUBBER HANGER (Type 2)



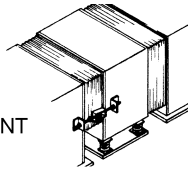
SPRING HANGER (Type 3)



**Note 26.** Isolation hangers (types 2 and 3) are used for suspended pipe and equipment and have rubber, springs, or a combination of spring and rubber elements. Criteria should be similar to open spring isolators, though lateral stability is less important. Where support rod angular misalignment is a concern, use hangers that have sufficient clearance and/or incorporate rubber bushings to prevent the rod from touching the housing. Swivel or traveler arrangements may be necessary for connections to piping systems subject to large thermal movements.

*Precompressed spring hangers* incorporate some means of precompression or preloading of the isolator spring to minimize movement of the isolated equipment or system. These are typically used on piping systems that can change mass substantially between installation and operation.

THRUST RESTRAINT (Type 5)

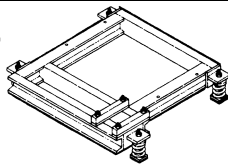


**Note 27.** Thrust restraints (type 5) are similar to spring hangers or isolators and are installed in pairs to resist the thrust caused by air pressure. These are typically sized to limit lateral movement to 6.4 mm or less.

DIRECT ISOLATION (Type A)

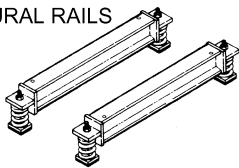
**Note 28.** Direct isolation (type A) is used when equipment is unitary and rigid and does not require additional support. Direct isolation can be used with large chillers, some fans, packaged air-handling units, and air-cooled condensers. If there is any doubt that the equipment can be supported directly on isolators, use structural bases (type B) or inertia bases (type C), or consult the equipment manufacturer.

STRUCTURAL BASES (Type B)



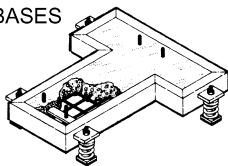
**Note 29.** Structural bases (type B) are used where equipment cannot be supported at individual locations and/or where some means is necessary to maintain alignment of component parts in equipment. These bases can be used with spring or rubber isolators (types 2 and 3) and should have enough rigidity to resist all starting and operating forces without supplemental hold-down devices. Bases are made in rectangular configurations using structural members with a depth equal to one-tenth the longest span between isolators. Typical base depth is between 100 and 300 mm, except where structural or alignment considerations dictate otherwise.

STRUCTURAL RAILS (Type B)



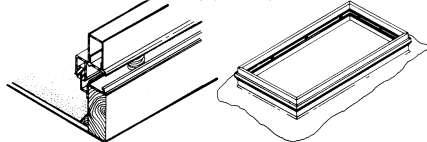
**Note 30.** Structural rails (type B) are used to support equipment that does not require a unitary base or where the isolators are outside the equipment and the rails act as a cradle. Structural rails can be used with spring or rubber isolators and should be rigid enough to support the equipment without flexing. Usual practice is to use structural members with a depth one-tenth of the longest span between isolators, typically between 100 and 300 mm, except where structural considerations dictate otherwise.

CONCRETE BASES (Type C)



**Note 31.** Concrete bases (type C) are used where the supported equipment requires a rigid support (e.g., flexible-coupled pumps) or excess heaving motion may occur with spring isolators. They consist of a steel pouring form usually with welded-in reinforcing bars, provision for equipment hold-down, and isolator brackets. Like structural bases, concrete bases should be sized to support piping elbow supports, rectangular or T-shaped, and for rigidity, have a depth equal to one-tenth the longest span between isolators. Base depth is typically between 150 and 300 mm unless additional depth is specifically required for mass, rigidity, or component alignment.

CURB ISOLATION (Type D)



**Note 32.** Curb isolation systems (type D) are specifically designed for curb-supported rooftop equipment and have spring isolation with a watertight, and sometimes airtight, assembly. *Roof top rails* consist of upper and lower frames separated by nonadjustable springs and rest on top of architectural roof curbs. *Isolation curbs* incorporate the roof curb into their design as well. Both kinds are designed with springs that have static deflections in the 25 to 75 mm range to meet the design criteria described in type 3. Flexible elastomeric seals are typically most effective for weatherproofing between the upper and lower frames. A continuous sponge gasket around the perimeter of the top frame is typically applied to further weatherproof the installation.

In specifying isolator deflection rather than isolation efficiency or transmissibility, a designer can compensate for floor stiffness and building resonances by selecting isolators that have more deflection than the supporting floor. Isolator deflection is related to the natural frequency of the isolators, and in turn, to the isolator efficiency. Vibration isolators are described in terms of maximum **static deflection**, which is the amount that a spring compresses under the weight of the equipment. If a spring is 50 mm long when unloaded and compresses to 25 mm when loaded, it has 25 mm of static deflection. Static deflection is directly related to vibration isolation efficiency: 25 mm static deflection equates to about 88% isolation of vibration energy, and 12 mm static deflection isolates roughly 50%. Static deflection is also related to the lowest frequency of vibration. Isolating very low frequencies (less than 20 Hz) requires very large static deflections of 100 mm or more. Beyond a certain point, springs can no longer do the job, in which case two-stage isolators or special air isolators are needed. The relationship between deflection and the natural frequency of the isolated system is given by Equation (36):

$$f_n = \frac{15.77}{\sqrt{d_{st}}} \quad (36)$$

where  $d_{st}$  is the static deflection in millimetres.

To apply the information from Table 47, base type, isolator type, and minimum deflection columns are added to the equipment schedule. These isolator specifications are then incorporated into mechanical specifications for the project.

Minimum deflections in the table are based on the experience of acoustical and mechanical consultants and vibration control manufacturers. Recommended isolator type, base type, and minimum static deflection are reasonable and safe recommendations for most HVAC equipment installations. The selections are based on concrete equipment room floors 100 to 300 mm thick with typical floor stiffness. The type of equipment, proximity to noise-sensitive areas, and type of building construction may alter these choices, especially in such cases as steel buildings with lightweight floors.

The following method develops isolator selection for specific applications:

1. Use Table 47 for floors specifically designed to accommodate mechanical equipment.
2. Use recommendations from the 6 m span column for equipment on ground-supported slabs adjacent to noise-sensitive areas.
3. For roofs and floors constructed with open web joists; thin, long span slabs; wooden construction; and any unusual light construction, evaluate all equipment with a mass of more than 140 kg to determine the additional deflection of the structure caused by the equipment. Isolator deflection should be up to 10 times the additional deflection or the deflection shown in Table 47, whichever is greater. If the required spring isolator deflection exceeds commercially available products, consider air springs or two-stage isolation, stiffen the supporting structure, or change the equipment location.
4. When mechanical equipment is adjacent to noise-sensitive areas, it is important to not only provide adequate vibration isolation but also to coordinate the construction of the surrounding floors, ceilings, and walls to isolate mechanical equipment room noise.

### Selecting Vibration Isolators to Meet Isolator Deflection Requirements

An overview of the procedure to select vibration isolators is as follows:

1. Establish total mass of equipment to be supported. This includes all equipment and support framework. The mass of piping connected to equipment may also need to be considered, because this may be partly supported from the equipment.

2. Establish operating mass (e.g., mass of water in a chiller or cooling tower).
3. Determine the location of supporting springs.
4. Calculate the distribution of weight onto each of the supporting springs using static force distribution methods.
5. Consider any dynamic forces that may change the mass distribution over the supporting springs.
6. Select vibration isolators to achieve the minimum deflection based on the vibration-isolator spring constant as advised by the manufacturer.

Note that the preceding procedure does not satisfy seismic restraint requirements, which must be considered in vibration isolator selection to meet applicable codes and standards.

Where requested or for sensitive projects, the following calculations may be presented for review:

1. Dry and operating masses (including any thrust forces)
2. Operating masses at each of the support points, considering the operating condition of the equipment
3. Isolator at each of the support points, given the selected vibration isolator spring constant
4. Wind forces, if installed outdoors.

### 3.5 VIBRATION- AND NOISE-SENSITIVE FACILITIES

Vibration-sensitive facilities identified in the section on Vibration Criteria are likely to require detailed assessment. Table 47 reflects typical application of vibration isolators in buildings to satisfy human comfort requirements. A specialist should be engaged to design vibration isolators for facilities with sensitive noise and vibration requirements, such as concert halls or facilities with electron microscopes or other diagnostic imaging equipment. The specialist will select vibration isolators based on the proximity to sensitive areas, structural design of the facility, and type and operating duty of vibration sources. Vibration propagation through soil may also need to be considered for any facilities close to rail lines or other vibration-generating sources.

### 3.6 INTERNAL VERSUS EXTERNAL ISOLATION

Vibration isolators are most effective if the isolator base is attached directly to the building structure at a support point that is highly stiff compared to the isolator. In many cases, the vibrating equipment (e.g., internal components of air-handling units) can be effectively isolated with internal vibration isolators, where only the moving parts (e.g., fan/motor assembly) are supported by the isolators. This approach can reduce the load supported by the isolators and thus can reduce the cost of isolation. The other primary advantage of internal isolation is reduction of vibration and structure-borne noise into the air-handling unit housing. Disadvantages of internal isolation can include the following:

- The isolator is often not easily visible in the field to verify that it is functioning properly.
- The isolator support point may be near the middle of a beam, which often provides inadequate stiffness for optimum isolator performance.
- Short circuiting of housed isolators, caused by horizontal thrust of the fan, can occur.
- Commonly provided isolators are not selected based on building support structure or noise criteria, and may not provide sufficient vibration control.
- Internal isolation does nothing to reduce vibration in equipment casing and structure caused by air movement.

Typically, vibration isolation devices should be applied to either the internal components or the external casing, but not both.

It is possible to use both internal and external vibration isolation on the same air-handling unit, but isolator stiffness selection must avoid resonances at or near normal fan and motor rotational speeds. There are multiple resonance frequencies to consider: if the fan or motor operates at or near one of these frequencies, vibration levels could become excessive. The probability of such an interaction increases significantly if the fan and motor are driven by a variable-frequency drive. Implementing both internal and external vibration isolation on the same unit should only be attempted with the guidance of an experienced vibration consultant.

### 3.7 ISOLATING VIBRATION AND NOISE IN PIPING SYSTEMS

All piping systems have mechanical vibration generated by the equipment and impeller-generated and flow-induced vibration and noise, which is transmitted by the pipe wall and the water column. In addition, equipment supported by vibration isolators exhibits some motion from pressure thrusts during operation. Vibration isolators have even greater movement during start-up and shutdown as equipment vibration passes through the isolators' resonance frequency. The piping system must be flexible enough to (1) reduce vibration transmission along the connected piping, (2) allow equipment movement without reducing the performance of vibration isolators, and (3) accommodate equipment movement or thermal movement of the piping at connections without imposing undue strain on the connections and equipment.

Flow noise and vibration in piping can be reintroduced by turbulence, sharp pressure drops, and entrained air; however, this can be minimized by sizing pipe so that velocities are 1.2 m/s maximum for pipe 50 mm and smaller and using a pressure drop limitation of 400 Pa per m of pipe length, with a maximum velocity of 3 m/s for larger pipe sizes. Take care not to exceed these limits.

#### Resilient Pipe Hangers and Supports

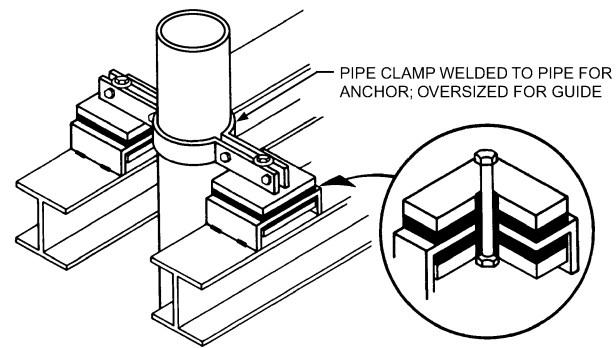
Resilient pipe hangers and supports may be used to prevent vibration and noise transmission from the piping system to the building structure and to provide flexibility in the piping.

**Suspended Piping.** Isolation hangers described in Note 26 of Table 47 should be used for all piping in equipment rooms and up to 15 m from vibration-isolated equipment and pressure-regulating valve (PRV) stations. To avoid reducing the effectiveness of equipment isolators, at least the first three hangers from the equipment should provide the same deflection as the equipment isolators, with a maximum limitation of 50 mm deflection; the remaining hangers should be spring or combination spring and rubber with 20 mm deflection.

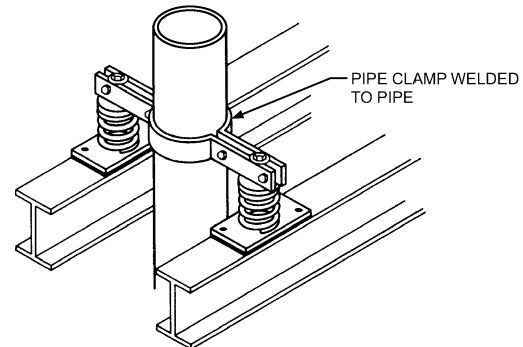
The first two hangers adjacent to the equipment should be the positioning or precompressed type, to prevent load transfer to equipment flanges when the piping system is filled. The positioning hanger aids in installing large pipe, and many engineers specify this type for all isolated pipe hangers for piping 200 mm and larger.

Piping over 50 mm in diameter that is suspended below or within 15 m of noise-sensitive areas should be hung with isolation hangers. Hangers adjacent to noise-sensitive areas should be the spring and rubber combination type 3.

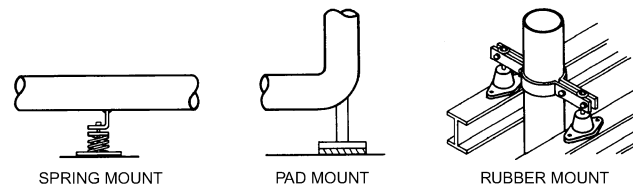
**Floor-Supported Piping.** Floor supports for piping in equipment rooms and adjacent to isolated equipment should use vibration isolators as described in Table 47. They should be selected according to the guidelines for hangers. The first two adjacent floor supports should be the restrained spring type, with a blocking feature that prevents load transfer to equipment flanges as the piping is filled or drained. Where pipe is subjected to large thermal movement, a slide plate (PTFE, graphite, or steel) should be installed on top of the isolator, and a thermal barrier should be used when rubber products are installed directly beneath steam or hot-water lines. Temperatures above 60°C can affect rubber isolators.



RESILIENTLY ISOLATED PIPE ANCHORS AND GUIDES



SPRING-ISOLATED RISER SYSTEM



CONVENTIONAL ISOLATORS AS PIPE SUPPORTS FOR LINES WITH EXPANSION JOINTS

Fig. 44 Resilient Anchors and Guides for Pipes

**Riser Supports, Anchors, and Guides.** Many piping systems have anchors and guides, especially in the risers, to permit expansion joints, bends, or pipe loops to function properly. Anchors and guides are designed to eliminate or limit (guide) pipe movement and must be rigidly attached to the structure; this is inconsistent with the resiliency required for effective isolation. The engineer should try to locate the pipe shafts, anchors, and guides in noncritical areas, such as next to elevator shafts, stairwells, and toilets, rather than adjoining noise-sensitive areas. Where concern about vibration transmission exists, some type of vibration isolation support or acoustical support is required for pipe supports, anchors, and guides.

Because anchors or guides must be rigidly attached to the structure, the isolator cannot deflect in the sense previously discussed, and the primary interest is that of an acoustical barrier. Heavy-duty rubber pads that can accommodate large loads with minimal deflection can provide such an acoustical barrier. Figure 44 shows some arrangements for resilient anchors and guides. Similar resilient supports can be used for the pipe.

Resilient supports for pipe, anchors, and guides can attenuate noise transmission, but they do not provide the resiliency required to isolate vibration. Vibration must be controlled in an anchor guide system by designing flexible pipe connectors and resilient isolation hangers or supports.

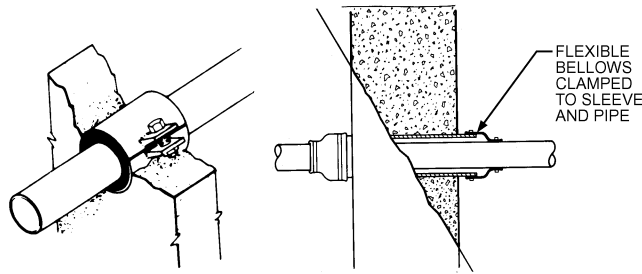


Fig. 45 Acoustical Pipe Penetration Seals

Completely spring-isolated riser systems that eliminate the anchors and guides have been used successfully in many instances and give effective vibration and acoustical isolation. In this type of isolation system, the springs are sized to accommodate thermal growth as well as to guide and support the pipe. These systems provide predictable load transfer because of thermal expansion and contraction, but require careful engineering to accommodate movements encountered not only in the riser but also in the branch takeoff to avoid overstressing the piping.

**Piping Penetrations.** HVAC systems typically have piping that must penetrate floors, walls, and ceilings. If these penetrations are not properly treated, they provide a path for airborne noise, which can destroy the acoustical integrity of the occupied space. Seal openings in pipe sleeves between noisy areas, such as equipment rooms, and occupied spaces with an acoustical barrier such as fibrous material and resilient acoustical caulking, or with engineered pipe penetration seals as shown in Figure 45.

**Flexible Pipe Connectors.** Flexible pipe connectors (1) provide piping flexibility to allow isolators to function properly, (2) protect equipment from strain caused by misalignment and expansion or contraction of piping, and (3) attenuate noise and vibration transmission along the piping (Figure 46). Connectors are available in two configurations: (1) hose type, a straight or slightly corrugated wall construction of either rubber or metal; and (2) arched or expansion-joint type, a short-length connector with one or more large-radius arches, of rubber, PTFE, or metal. Metal expansion joints are acoustically ineffective and are seldom successfully used for vibration and sound isolation in HVAC systems; they should not be expected to substitute for conventional pipe vibration isolators.

To accommodate pressure thrust, flexible connectors require an end restraint, which is either (1) added to the connector, (2) incorporated by its design, (3) added to the piping system (anchoring), or (4) built in by the stiffness of the system. Connector extension caused by pressure thrust on isolated equipment should also be considered when flexible connectors are used. Overextension causes failure. Manufacturers' recommendations on restraint, pressure, and temperature limitations must be strictly observed. Sometimes these restraint systems almost eliminate the effects of the flexible connector.

**Hose Connectors.** Hose connectors accommodate lateral movement perpendicular to length and have very limited or no axial movement capability. Rubber hose connectors can have molded or hand-wrapped construction with wire reinforcing, and are available with metal-threaded end fittings or integral rubber flanges. Application of threaded fittings should be limited to 75 mm and smaller pipe diameter. The fittings should be the mechanically expanded type to minimize the possibility of pressure thrust blowout. Flanged types are available in larger pipe sizes. Table 48 lists recommended lengths.

Metal hose is constructed with a corrugated inner core and a braided cover, which helps attain a pressure rating and provides end

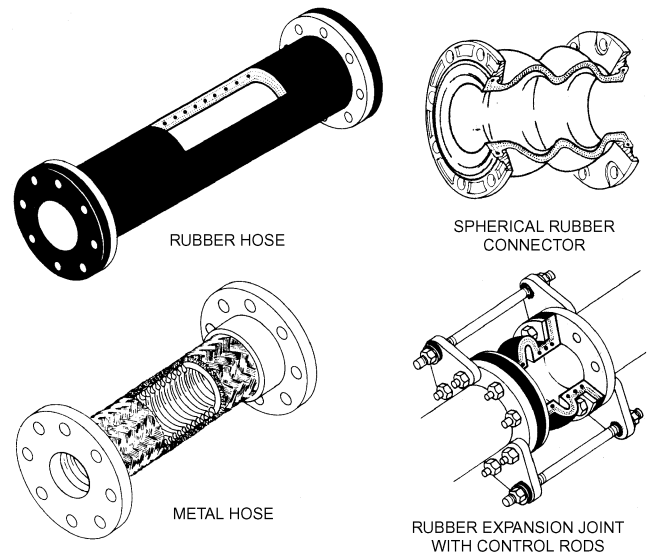


Fig. 46 Flexible Pipe Connectors

Table 48 Recommended Live Lengths<sup>a</sup> of Flexible Rubber and Metal Hose

Nominal Diameter, mm	Length, <sup>b</sup> mm	Nominal Diameter, mm	Length, <sup>b</sup> mm
20	300	100	450
25	300	125	600
40	300	150	600
50	300	200	600
65	300	250	600
80	450	300	900

<sup>a</sup>Live length is end-to-end length for integral flanged rubber hose and is end-to-end less total fitting length for all other types.

<sup>b</sup>Per recommendations of Rubber Expansion Division, Fluid Sealing Association.

restraints that eliminate the need for supplemental control assemblies. Short lengths of metal hose or corrugated metal bellows, or pump connectors, are available without braid and have built-in control assemblies. Metal hose is used to control misalignment and vibration rather than noise and is used primarily where temperature or pressure of flow media precludes the use of other material. Table 48 provides recommended lengths.

**Expansion Joint or Arched Connectors.** Expansion joint or arched connectors have one or more convolutions or arches and can accommodate all modes of axial, lateral, and angular movement and misalignment. When made of rubber, they are commonly called expansion joints, spool joints, or spherical connectors; in PTFE, they are known as couplings or expansion joints.

Rubber expansion or spool joints are available in two basic types: (1) hand-wrapped with wire and fabric reinforcing, and (2) molded with fabric and wire or with high-strength fabric only (instead of metal) for reinforcing. The handmade type is available in a variety of materials and lengths for special applications. Rubber spherical connectors are molded with high-strength fabric or tire cord reinforcing instead of metal. Their distinguishing characteristic is a large-radius arch. The shape and construction of some designs allow use without control assemblies in systems operating to 1 MPa, and are the most effective for minimizing vibration transmission. Where thrust restraints are not built in, they must be used as described for rubber hose joints.

PTFE expansion joints and couplings are similar in construction to rubber expansion joints with reinforcing metal rings.

In evaluating these devices, consider temperature, pressure, and service conditions as well as each device's ability to attenuate vibration and noise. Metal hose connections can accommodate misalignment and attenuate mechanical vibration transmitted through the pipe wall, but do little to attenuate noise. This type of connector has superior resistance to long-term temperature effects. Rubber hose, expansion joints, and spherical connectors attenuate vibration and impeller-generated noise transmitted through the pipe wall. Because rubber expansion joint and spherical connector walls are flexible, they can grow volumetrically and attenuate noise and vibration at blade-pass frequencies. This is a particularly desirable feature in uninsulated piping systems, such as for condenser or domestic water, which may run adjacent to noise-sensitive areas. However, high pressure has a detrimental effect on the ability of the connector to attenuate vibration and noise.

Because none of the flexible pipe connectors control flow or velocity noise or completely isolate vibration and noise transmission to the piping system, resilient pipe hangers and supports should be used; these are shown in Note 26 for Table 47 and are described in the Resilient Pipe Hangers and Supports section.

### Isolating Duct Vibration

Flexible canvas and rubber duct connections should be used at fan intake and discharge. However, they are not completely effective because they become rigid under pressure, allowing the vibrating fan to pull on the duct wall. To maintain a slack position of the flexible duct connections, thrust restraints (see Note 27, Table 47) should be used on all equipment as indicated in Table 47.

Although vibration transmission from ducts isolated by flexible connectors is not common, flow pulsations within the duct can cause mechanical vibration in the duct walls, which can be transmitted through rigid hangers. Spring or combination spring and rubber hangers are recommended wherever ducts are suspended below or near a noise-sensitive area.

## 3.8 SEISMIC PROTECTION

Seismic restraint requirements are specified by applicable building codes that define design forces to be resisted by the mechanical system, depending on building location and occupancy, location of the system in the building, and whether it is used for life safety. Where required, seismic protection of resiliently mounted equipment poses a unique problem, because resiliently mounted systems are much more susceptible to earthquake damage from overturning forces, the impact limits of bare restraints, and resonances inherent in vibration isolators.

A deficiency in seismic restraint design or anchorage may not become apparent until an earthquake occurs, with possible catastrophic consequences. Adequacy of the restraint system and anchorage to resist code design forces must be verified before the event, by either equipment tests, calculations, or dynamic analysis, depending on the item, with calculations or dynamic analysis performed under the direction of a professional engineer. These analysis items may be supplied as a package by the vibration isolation vendor.

Restraints for floor-mounted equipment should be designed with adequate clearances so that they are not engaged during normal operation of the equipment. Contact surfaces (snubbers) should be protected with resilient pad material to limit shock during an earthquake, and restraints should be strong enough to resist the forces in any direction. The integrity of these devices can be verified by a comprehensive analysis, but is more frequently verified by laboratory tests.

Calculations or dynamic analyses should have an engineer's seal to verify that input forces are obtained in accordance with code or specification requirements. Additionally, a professional engineer should make the anchorage calculations in accordance with accepted standards. For more information, see Chapter 55.

## 3.9 VIBRATION INVESTIGATIONS

Theoretically, a vibration isolation system can be designed to mitigate even the most extreme sources of mechanical vibration. However, isolators should not be used to mask a condition that should be corrected before it damages the equipment and its operation. High vibration levels can indicate a faulty equipment operating condition in need of correction, or they can be a symptom of a resonance interaction between a vibrating piece of equipment and the structure(s) on which it is supported or to which it is attached.

Vibration investigations can include

- Measurement of vibration levels on vibrating equipment (see Figure 43 for recommended vibration criteria)
- Measurement of vibration levels in building structures to which vibrating equipment is connected, such as a building floor, piping systems, etc. (see Figure 42 and Table 45 for recommended building vibration criteria)
- Examination of equipment vibration generated by system components, such as bearings, drives, pumps, etc.
- Measurement of the natural frequencies (resonances) of vibrating equipment or connected structure(s)
- Examination of equipment installation factors, such as equipment alignment, vibration isolator placement, etc. (see Table 47)
- Measurement of the unbalance of reciprocating or rotating equipment components

## 4. COMMISSIONING

In the initial design and final commissioning phases of an HVAC system, sound criteria are needed to determine the degree of noise impact and the amount of noise and vibration reduction required for acceptable background sound and vibration levels based on occupancy usage. This chapter is intended primarily to assist with the design phase and provide limited assistance with diagnosing problems. Detailed diagnosis of problems may require the assistance of a vibration consultant or an engineer experienced in HVAC system noise and vibration analysis. Consult the section on Testing for Sound and Vibration in Chapter 38 for the commissioning phase.

## 5. TROUBLESHOOTING

Despite all precautions, situations may arise where there is disturbing noise and vibration. Problems can be identified and corrected by

- Determining which equipment or system is the source of the problem
- Determining whether the problem is one of airborne sound, structureborne noise, or vibration
- Applying appropriate solutions

Troubleshooting can be time consuming, expensive, and difficult, and use of an experienced acoustical consultant is often warranted. Proper diagnosis of the problem is most critical to allow for developing the right solution. Once a noise or vibration transmission problem exists, occupants become more sensitive and require greater reduction of the sound and vibration levels than would initially have been satisfactory. The need for troubleshooting should be minimized by properly designing, installing, and testing the system as soon as it is operational and before the building is occupied.

## 5.1 DETERMINING PROBLEM SOURCE

A simple, accurate method of determining the problem source is to turn individual pieces of equipment on and off until the vibration or noise is eliminated. Because the source of the problem is often more than one piece of equipment or the interaction of two or more systems, it is always good practice to double check by shutting off the system and operating the equipment individually. Reynolds and Bevirt (1994) and Schaffer (2005) provide practical information on the measurement and assessment of sound and vibration in buildings.

## 5.2 DETERMINING PROBLEM TYPE

Once the source is identified, the next step is to determine whether the problem is one of noise or vibration. Clearly perceptible vibration is often a clue that vibration transmission is the major cause of the problem. The possibility that low-mass wall or ceiling panels are excited by airborne noise should be considered. However, even if the vibration is not readily perceptible, the problem may still be one of vibration transmission causing structureborne noise. This can be checked using the following procedure:

- If a sound level meter is available, some readings should be taken. If the difference between C-weighted and overall (unweighted or linear) readings is greater than 6 dB, or if the slope of the acoustic spectrum is steeper than 6 dB per octave at low frequencies (below 63 Hz), vibration is likely a contributing factor.
- If excessive noise is found close to the equipment and/or main ductwork, airborne noise is probably the main contributor.
- If the affected area is remote from source equipment, there is no problem in intermediary spaces, and noise does not appear to be coming from the duct system or diffusers, structureborne noise is probably the cause.

One important step in diagnosing many noise or vibration problems, particularly if the affected area is close to the mechanical equipment room, is to check the equipment's vibration isolation system. A simple test is to have one person listen in the affected area while another shouts loudly in the equipment room. If the voice cannot be heard, the problem is likely one of structureborne noise. If the voice can be heard, check for openings in the wall or floor separating the areas. If no such openings exist, the structure separating the areas does not provide adequate transmission loss. In these situations, see the section on Mechanical Equipment Room Sound Isolation for possible solutions.

### Noise Problems

If ductborne sound (i.e., noise from grilles or diffusers or duct breakout noise) appears to be the problem, measure the sound pressure levels and compare them with the design criteria (NC, RC, etc.). It is often helpful to obtain sound data with and without terminal devices installed. Comparison of the two results shows how much noise a given terminal device contributes. If this reveals the responsible components, the engineer can analyze each sound source using the procedures presented in this chapter to determine whether sufficient attenuation has been provided.

If the sound source is a fan, pump, or similar rotating equipment, an important question is whether it is operating near the most efficient part of its operating curve, where most equipment operates best and generates predictable levels of sound and vibration as published by equipment manufacturers and used in the building design. Excessive vibration and noise can occur if a fan or pump is trying to move too little or too much air or water. Check that vanes, dampers, and valves are in the correct operating position and that the system has been properly balanced.

### Vibration Problems

Vibration and structureborne noise problems can be caused by

- Equipment improperly specified or installed, poorly balanced, misaligned, or operating outside of design conditions
- Equipment with inadequate or improper vibration isolation
- Flanking transmission paths such as rigid pipe or duct connections, obstructions under the base of vibration-isolated equipment, improperly installed equipment seismic restraints shorting vibration isolation, or shipping blocks not removed after the equipment has been installed and in operation
- Excessive floor flexibility indicative of improper structural support conditions for equipment or inadequate or improper vibration isolation
- Resonances in equipment, vibration isolation system, building structure, or connected structures (e.g., piping)

Most field-encountered problems result from improperly selected or installed isolators and flanking paths of transmission, which can be simply evaluated and corrected. If the equipment lacks vibration isolators, in many cases it is possible to add isolators (see Table 47) without altering connected ducts or piping by using structural brackets. Floor flexibility and resonance problems are sometimes encountered and usually require analysis by experts. However, the procedures in the following sections can help identify such problems.

**Testing Vibration Isolation Systems.** Improperly functioning vibration isolation systems are the cause of most field-encountered problems and can be evaluated and corrected by the following procedures:

1. Ensure that the system is free floating by bouncing the base, which should cause the equipment to move up and down freely and easily. Note that this may not be practical on very heavy equipment. On floor-mounted equipment, check that there are no obstructions between the base and the floor that would short circuit the isolation system. This is best accomplished by passing a rod under the equipment. A small obstruction might allow the base to rock, giving the impression that it is free floating when it is not. On suspended equipment, make sure that rods are not touching the hanger box. Rigid connections such as pipes and ducts can prevent equipment from floating freely, prohibit isolators from functioning properly, and provide flanking paths for vibration transmission.
2. Determine whether isolator static deflection is as specified or required, changing it if necessary, as recommended in Table 47. A common problem is inadequate deflection caused by underloaded isolators. Overloaded isolators are not generally a problem as long as the system is free-floating and there is space between the spring coils.

With most commonly used spring isolators, static deflection can be determined by measuring the operating height and comparing it to free-height information available from the manufacturer. Once the actual isolator deflection is known, determine its adequacy by comparing it with the recommended deflection in Table 47.

If a transmission problem exists, it may be caused by (1) excessively rough equipment operation, (2) the system not being free floating or flanking path transmission, or (3) a resonance or floor stiffness problem.

It is easy to determine the natural frequency of spring isolators from the static deflection determined by spring height measurements, but these measurements are difficult with pad and elastomeric isolators and are often not accurate in determining their natural frequencies. Although such isolators can theoretically provide natural frequencies as low as 4 Hz, they typically provide higher natural frequencies and generally do not provide the desired isolation efficiencies for upper floor equipment locations. Therefore, it is recommended to avoid using elastomeric mounts in general for (1) equipment on elevated floors, (2) major equipment, (3) critical applications, and (4) equipment on variable-speed operation; in all

such cases, spring isolation should be considered and properly specified.

In general, it is very difficult to determine whether vibration isolation efficiencies intended in design have been achieved in field installations using field vibration measurements. However, vibration measurements can readily be made on vibrating equipment, equipment supports, floors supporting vibration-isolated equipment, and floors in adjacent areas to determine whether vibration criteria specified in [Table 45](#) or in [Figure 42](#) have been achieved.

**Floor Flexibility Problems.** Floor flexibility problems can occur with heavy equipment installed on long-span floors or thin slabs and with rooftop equipment installed on light structures of open web joist construction. If floor flexibility is suspected, the isolators should be one-tenth or less as stiff as the floor to eliminate the problem. Floor stiffness can be determined by calculating the additional floor deflection caused by a specific piece of equipment.

For example, if a 5000 kg piece of equipment causes floor deflection of an additional 2.5 mm, floor stiffness is 19.6 MN/m, and an isolator combined stiffness of 1.96 MN/m or less must be used. Note that floor stiffness or spring rate, not total floor deflection, is determined. In this example, the total floor deflection might be 25 mm, but if the problem equipment causes 2.5 mm of that deflection, 2.5 mm is the factor that identifies floor stiffness of 19.6 MN/m.

As a general guideline, limiting the additional floor deflection (not total deflection) due to the mass of the equipment to 7.5 mm is advisable, even when the equipment is provided with proper vibration isolation. This may need to be further reduced for vibration in acoustically critical adjacencies.

**Resonance Problems.** These problems occur when the equipment's operating speed is the same as or close to the resonance frequency of (1) an equipment component such as a fan shaft or bearing support pedestal, (2) the vibration isolation system, or (3) the resonance frequency of the floor or other building component, such as a wall. Vibration resonances can cause excessive equipment vibration levels, as well as objectionable and possibly destructive vibration transmission in a building. These conditions must always be identified and corrected. Note that, if building structures have resonant frequencies, it is important to isolate equipment to avoid energizing those frequencies in the structure. Structural changes can also reduce susceptibility to other excitation sources (e.g., walking, rhythmic activity).

When vibrating mechanical equipment is mounted on vibration isolators on a flexible floor, there are two resonance frequencies that must be considered: that of the floor and that of the isolated equipment. The lower frequency should be controlled by the stiffness (and consequently the static deflection) of the vibration isolators. This frequency should be significantly less than the normal operating speed (or frequency) of the mechanical equipment and is generally not a problem. The higher resonance frequency is associated with and primarily controlled by the stiffness of the supporting structure. This resonance frequency is usually not affected by increasing or decreasing the static deflection of the mechanical equipment vibration isolators.

Sometimes, when the floor under mechanical equipment is flexible (as occurs with some long-span floor systems and with roof systems supporting rooftop packaged units), the operating speed of the mechanical equipment can coincide with the floor resonance frequency. When this occurs, changing the static deflection of the vibration isolators may not solve the problem. Alternatives include changing the rotating speed of the equipment, stiffening the structure, or adjusting a variable-frequency drive to avoid the resonant frequency. Also, adding mass such as a house-keeping pad in concrete under the isolator could be a possible solution.

**Vibration Isolation System Resonance.** Always characterized by excessive equipment vibration, vibration isolation system rigid-body resonance (characterized by the mass of the equipment vibrating on the stiffness of the isolators) usually results in objectionable transmission to the building structure. However, transmission might not occur if the equipment is on grade or on a stiff floor. Vibration isolation system rigid-body resonances can be measured with instrumentation or, more simply, by determining the isolator's natural frequency (as described in the section on Testing Vibration Isolation Systems) and comparing this figure to the operating speed of the equipment.

When a vibration isolation system resonance problem exists, the system natural frequency must be changed using the following guidelines:

- If equipment is installed on excessively stiff pad or rubber elastomeric mounts, isolators with the deflection recommended in [Table 47](#) should be installed.
- If equipment is installed on spring isolators and there is objectionable vibration or noise transmission to the structure, determine whether the isolator is providing the designed static deflection. For example, an improperly selected or installed nominal 50 mm deflection isolator could be experiencing only 3 mm deflection under its static load, which would be in resonance with equipment operating at 500 rpm. If this is the case, the isolators should be replaced with ones having enough capacity to provide the requisite 50 mm deflection. However, if there is no transmission problem with the isolators, it is not necessary to use greater-deflection isolators than can be conveniently installed.
- If equipment is installed on spring isolators and there is objectionable noise or vibration transmission, replace the isolators with springs of the deflection recommended in [Table 47](#).
- If equipment is installed on spring isolators of the recommended stiffness and there is objectionable high-frequency (200 Hz or greater) noise or vibration, it is possible that resonances internal to the spring are the culprit. These resonances, sometimes called **surge frequencies**, can be important in applications where equipment (e.g., screw compressors, inverters) generates high-frequency noise. To control their adverse effects, many isolator designs incorporate an elastomeric pad under the spring. It may also be possible to identify an elastomeric mount that can provide the desired static deflection; these typically have better high-frequency characteristics than springs.

**Building Resonances.** These problems occur when some part of the building structure has a resonance frequency coincident with the disturbing frequency (often the operating speed) of some of the equipment. These problems can exist even if the isolator deflections recommended in [Table 47](#) are used. The resulting objectionable noise or vibration should be evaluated and corrected. Often, the resonance problem is associated with the floor on which the equipment is installed, but it can also occur in a remotely located floor, wall, or other building component. If a noise or vibration problem has a remote source that cannot be associated with piping or ducts, building resonance must be suspected.

Building resonance problems can be resolved by the following:

- Reduce the vibration force by balancing the equipment. This is not a practical solution for a true resonance problem. However, it is effective when the disturbing frequency is close to the floor's natural frequency, as evidenced by the equal displacement of the floor and the equipment, especially when the equipment is operating with excessive vibration.
- Change the disturbing frequency by changing the equipment operating speed. This is practical only for belt-driven equipment, or equipment driven by variable-frequency drives.

- Modify the structure to shift the structural response. Although this requires upsizing the structure and can be costly, if feasible it is often the most effective means of resolving vibration issues.

## REFERENCES

- AHRI. 2012. Sound rating of ducted air moving and conditioning equipment. ANSI/AHRI *Standard* 260-2012. Air-Conditioning, Heating, and Refrigeration Institute, Arlington, VA.
- AHRI. 2011. Sound performance rating of large air-cooled outdoor refrigerating and air-conditioning equipment. ANSI/AHRI *Standard* 370-2011. Air-Conditioning, Heating, and Refrigeration Institute, Arlington, VA.
- AHRI. 2008. Method of measuring machinery sound within an equipment space. ANSI/AHRI *Standard* 575-2008. Air-Conditioning, Heating, and Refrigeration Institute, Arlington, VA.
- AHRI. 2008. Performance rating of air terminals. ANSI/AHRI *Standard* 880-2008. Air-Conditioning, Heating, and Refrigeration Institute, Arlington, VA.
- AHRI. 2008. Procedure for estimating occupied space sound levels in the application of air terminals and air outlets. *Standard* 885-2008. Air-Conditioning, Heating, and Refrigeration Institute, Arlington, VA.
- AMCA. 2014. Reverberant room method for sound testing of fans. ANSI/AMCA *Standard* 300-2014. Air Movement and Control Association International, Arlington Heights, IL.
- ANSI. 2014. Sound level meters—Part 1: Specifications. *Standard* S1.4-2014. American National Standards Institute, Washington, D.C.
- ANSI. 2014. Sound level meters—Part 2: Pattern evaluation tests. *Standard* S1.4-2014. American National Standards Institute, Washington, D.C.
- ANSI. 2014. Octave-band and fractional-octave-band filters—Part 1: Specifications. *Standard* S1.11-2014. American National Standards Institute, Washington, D.C.
- ANSI. 2012. Guide to the evaluation of human exposure to vibration in buildings. *Standard* S2.71-1983 (R2012). American National Standards Institute, Washington, D.C.
- ANSI. 2008. Criteria for evaluating room noise. *Standard* S12.2-2008. American National Standards Institute, Washington, D.C.
- ASA. 2010. Acoustical performance criteria, design requirements, and guidelines for schools, part 1: Permanent schools, and part 2: Relocatable classroom factors. ANSI/ASA *Standard* S12.60-2010. Acoustical Society of America, Melville, NY.
- ASA. 2015. Procedure for measuring the ambient noise level in a room. ANSI/ASA *Standard* S12.72-2015. Acoustical Society of America, Melville, NY.
- ASHRAE. 1997. Laboratory method of testing to determine the sound power in a duct. ASHRAE *Standard* 68-1997/AMCA *Standard* 330-97.
- ASHRAE. 2011. Method of testing for rating the performance of air outlets and inlets. ANSI/ASHRAE *Standard* 70-2006 (RA2011).
- ASTM. 2013. Standard test method for laboratory measurements of acoustical and airflow performance of duct liner materials and prefabricated silencers. *Standard* E477-2013. American Society for Testing and Materials, West Conshohocken, PA.
- Beatty, J. 1987. Discharge duct configurations to control rooftop sound. *Heating/Piping/Air Conditioning* (July).
- Beranek, L.L. 1960. *Noise reduction*. McGraw-Hill, New York.
- Beranek, L.L. 1971. *Noise and vibration control*. McGraw-Hill, New York.
- Beranek, L.L. 1989. Balanced noise criterion (NCB) curves. *Journal of the Acoustical Society of America* (86):650-654.
- Blazier, W.E., Jr. 1981a. Revised noise criteria for design and rating of HVAC systems. *ASHRAE Transactions* 87(1):647-657. *Paper* CH-81-06-2.
- Blazier, W.E., Jr. 1981b. Revised noise criteria for application in the acoustical design and rating of HVAC systems. *Noise Control Engineering Journal* 16(2):64-73.
- Blazier, W.E., Jr. 1993. Control of low frequency noise in HVAC air-handling equipment and systems. *ASHRAE Transactions* 99(2):1031-1036. *Paper* DE-93-17-2.
- Blazier, W.E., Jr. 1995. Sound quality considerations in rating noise from heating, ventilating and air-conditioning (HVAC) systems in buildings. *Noise Control Engineering Journal* 43(3).
- Blazier, W.E., Jr. 1997. RC Mark II; a refined procedure for rating the noise of heating, ventilating and air-conditioning (HVAC) systems in buildings. *Noise Control Engineering Journal* 45(6).
- Broner, N. 1994. Low-frequency noise assessment metrics—What do we know? (RP-714). *ASHRAE Transactions* 100(2):380-388. *Paper* 3821.
- Bullock, C.E. 1970. Aerodynamic sound generation by duct elements. *ASHRAE Transactions* 76(2):97-109. *Paper* KA-2147.
- Cummings, A. 1983. Acoustic noise transmission through the walls of air-conditioning ducts. *Final Report*, Department of Mechanical and Aerospace Engineering, University of Missouri, Rolla.
- Cummings, A. 1985. Acoustic noise transmission through duct walls. *ASHRAE Transactions* 91(2A):48-61. *Paper* 2889.
- Cunefare, K., and A. Michaud. 2008. Reflection of airborne noise at duct terminations. ASHRAE Research Project RP-1314, *Final Report*.
- Ebbing, C.E., and W.E. Blazier, Jr. 1992. HVAC low frequency noise in buildings. *Proceedings INTER-NOISE* 92(2):767-770.
- Ebbing, C.E., and W.E. Blazier, Jr. 1998. *Application of manufacturer's sound data*. ASHRAE.
- Ebbing, C.E., D. Fragnito, and S. Inglis. 1978. Control of low frequency duct-generated noise in building air distribution systems. *ASHRAE Transactions* 84(2):191-203. *Paper* AL-2503.
- Egan, M.D. 1988. *Architectural acoustics*. McGraw-Hill, New York.
- Harold, R.G. 1986. Round duct can stop rumble noise in air-handling installations. *ASHRAE Transactions* 92(2A):189-202. *Paper* 2988.
- Harold, R.G. 1991. Sound and vibration considerations in rooftop installations. *ASHRAE Transactions* 97(1):445-451. *Paper* NY-91-03-3.
- IEST. 2007. Considerations in clean room design. *IEST Recommended Practice* RP-CC012.2. Institute of Environmental Sciences and Technology, Rolling Meadows, IL.
- Ingard, U., A. Oppenheim, and M. Hirschorn. 1968. Noise generation in ducts (RP-37). *ASHRAE Transactions* 74(1):V.1.1-V.1.10.
- IRD. 1988. *Vibration technology*, vol. 1. IRD Mechanalysis, Columbus, OH.
- ISO. 2003. Mechanical vibration and shock—Evaluation of human exposure to whole body vibration, Part 2: Vibration in buildings. *Standard* 2631-2-2003. International Organization for Standardization, Geneva, Switzerland.
- ISO. 1996. Acoustics—Attenuation of sound during propagation outdoors—Part 2: General method of calculation. *Standard* 9613-2-1996. International Organization for Standardization, Geneva, Switzerland.
- Kuntz, H.L. 1986. The determination of the interrelationship between the physical and acoustical properties of fibrous duct liner materials and lined duct sound attenuation. *Report* 1068. Hoover Keith and Bruce, Houston, TX.
- Kuntz, H.L., and R.M. Hoover. 1987. The interrelationships between the physical properties of fibrous duct lining materials and lined duct sound attenuation. *ASHRAE Transactions* 93(2):449-470. *Paper* 3082.
- Lilly, J. 1987. Breakout in HVAC duct systems. *Sound & Vibration* 21(10).
- Machen, J., and J.C. Haines. 1983. Sound insertion loss properties of linacoustic and competitive duct liners. *Report* 436-T-1778. Johns-Manville Research and Development Center, Denver, CO.
- Mouratidis, E., and J. Becker. 2004. The acoustic properties of common HVAC plena (RP-1026). *ASHRAE Transactions* 110(2):597-696. *Paper* NA-04-3-1.
- Murray, T.M., D.E. Allen, and E.E. Ungar. 1997. *Steel design guide series 11: Floor vibrations due to human activity*. American Institute of Steel Construction, Chicago.
- OSHA. 2011. Occupational noise exposure. 29CFR1910.95. *Code of Federal Regulations*, Occupational Safety and Health Administration, U.S. Department of Labor, Washington, D.C.
- Persson-Wayne, K., S. Benton, H.G. Leventhall, and R. Rylander. 1997. Effects on performance and work quality due to low frequency ventilation noise. *Journal of Sound and Vibration* 205(4):467-474.
- Reynolds, D.D., and W.D. Bevirt. 1994. *Procedural standards for the measurement and assessment of sound and vibration*. National Environmental Balancing Bureau, Rockville, MD.
- Reynolds, D.D., and J.M. Bledsoe. 1989a. Sound attenuation of unlined and acoustically lined rectangular ducts. *ASHRAE Transactions* 95(1):90-95. *Paper* 3207.
- Reynolds, D.D., and J.M. Bledsoe. 1989b. Sound attenuation of acoustically lined circular ducts and radiused elbows. *ASHRAE Transactions* 95(1):96-99. *Paper* 3208.
- Reynolds, D.D., and J.M. Bledsoe. 1991. *Algorithms for HVAC acoustics*. ASHRAE.
- Schaffer, M.E. 2005. *A practical guide to noise and vibration control for HVAC systems*, 2nd ed. ASHRAE.

- Schultz, T.J. 1985. Relationship between sound power level and sound pressure level in dwellings and offices. *ASHRAE Transactions* 91(1A): 124-153.
- Stabley, R.E. 2006. Sound ratings of water-cooled chillers—Sound pressure or power levels? In *Proceedings from Inter-Noise 2006*, Honolulu. Institute of Noise Control Engineering of the USA, Indianapolis, IN.
- Thompson, J.K. 1981. The room acoustics equation: Its limitation and potential. *ASHRAE Transactions* 87(2):1049-1057. Paper CI-81-12-2.
- Ver, I.L. 1978. A review of the attenuation of sound in straight lined and unlined ductwork of rectangular cross section. *ASHRAE Transactions* 84(1):122-149. Paper AT-2477-2478.
- Ver, I.L. 1982. A study to determine the noise generation and noise attenuation of lined and unlined duct fittings. Report 5092. Bolt, Beranek and Newman, Boston.
- Ver, I.L. 1983a. Noise generation and noise attenuation of duct fittings—A review: Part I (RP-265). *ASHRAE Transactions* 90(2A):354-382. Paper KC-2849.
- Ver, I.L. 1983b. Noise generation and noise attenuation of duct fittings—A review: Part II (RP-265). *ASHRAE Transactions* 90(2A):383-390. Paper KC-2850.
- Wang, L.M., E.E. Ryherd, and C.C. Novak. 2013. Productivity and perception based evaluation of indoor noise criteria. ASHRAE Research Project RP-1322, *Final Report*.
- Warnock, A.C.C. 1998. Transmission of sound from air terminal devices through ceiling systems. *ASHRAE Transactions* 104(1A):650-657. Paper 4160.
- Wells, R.J. 1958. Acoustical plenum chambers. *Noise Control* (July).
- Woods Fan Division. 1973. *Design for sound*. English Electric Company.

## BIBLIOGRAPHY

- AHRI. 2013. Performance and calibration of reference sound sources. ANSI/AHRI Standard 250-2013. Air-Conditioning, Heating, and Refrigeration Institute, Arlington, VA.
- AHRI. 2008. Sound rating of outdoor unitary equipment. ANSI/AHRI Standard 270-2008. Air-Conditioning, Heating, and Refrigeration Institute, Arlington, VA.
- AHRI. 2010. Application of sound rating levels of outdoor unitary equipment. ANSI/AHRI Standard 275-2010. Air-Conditioning, Heating, and Refrigeration Institute, Arlington, VA.
- AHRI. 2011. Requirements for the qualification of reverberant rooms in the 63 Hz octave band. ANSI/AHRI Standard 280-2011. Air-Conditioning, Heating, and Refrigeration Institute, Arlington, VA.
- AHRI. 2008. Sound rating and sound transmission loss of packaged terminal equipment. ANSI/AHRI Standard 300-2008. Air-Conditioning, Heating, and Refrigeration Institute, Arlington, VA.
- AHRI. 2008. Sound rating of non-ducted indoor air-conditioning equipment. ANSI/AHRI Standard 350-2008. Air-Conditioning, Heating, and Refrigeration Institute, Arlington, VA.
- AHRI. 2011. Method of measuring sound and vibration of refrigerant compressors. ANSI/AHRI Standard 530-2011. Air-Conditioning, Heating, and Refrigeration Institute, Arlington, VA.

- AIA. 2006. *Guidelines for design and construction of health care facilities*. American Institute of Architects, Washington, D.C.
- ANSI. 2012. Mechanical vibration and shock—Evaluations of human exposure to whole-body vibration—Part 1: General requirements. ANSI/ASA Standard S2.72-2010 (R2012). American National Standards Institute, Washington, D.C.
- ANSI. 2012. Determination of sound power levels and sound energy levels of noise sources using sound pressure—Precision methods for reverberation test rooms. ANSI/ASA Standard S12.51-2012/ISO Standard 3741:2010. American National Standards Institute, Washington, D.C.
- ANSI. 2011. Determination of sound power levels and sound energy levels of noise sources using sound pressure—Engineering methods for an essentially free field over a reflecting plane. ANSI/ASA Standard S12.54-2011/ISO Standard 3744:2010. American National Standards Institute, Washington, D.C.
- ASHRAE. 2013. Ventilation for acceptable indoor air quality. ANSI/ASHRAE Standard 62.1-2013.
- DHHS. 2014. *Thirteenth report on carcinogens*. U.S. Department of Health and Human Services, Public Health Service, Washington, D.C. Available from <http://ntp.niehs.nih.gov/pubhealth/roc/roc13/index.html>.
- Environment Canada. 1994. Mineral fibres: Priority substances list assessment report. *Canadian Environmental Protection Act*, Ottawa.
- Morey, P.R., and C.M. Williams. 1991. Is porous insulation inside an HVAC system compatible with healthy building? ASHRAE IAQ Symposium.
- Reynolds, D.D., and W.D. Bevirt. 1989. *Sound and vibration design and analysis*. National Environmental Balancing Bureau, Rockville, MD.
- Schultz, T.J. 1972. *Community noise ratings*. Applied Science Publishers, London.
- SMACNA. 2006. *HVAC systems duct design*, 4th ed. Sheet Metal and Air Conditioning Contractors' National Association, Vienna, VA.
- Ver, I.L. 1983. Prediction of sound transmission through duct walls: Breakout and pickup. *ASHRAE Transactions* 90(2A):391-413. Paper KC-2851.

## RESOURCES

- Acoustical Society of America (ASA)..... [www.acousticalsociety.org](http://www.acousticalsociety.org)
- Associated Air Balance Council (AABC)..... [www.aabc.com](http://www.aabc.com)
- Institute of Noise Control Engineering (INCE)..... [www.inceusa.org](http://www.inceusa.org)
- National Council of Acoustical Consultants (NCAC)..... [www.ncac.com](http://www.ncac.com)
- National Environmental Balancing Bureau (NEBB)..... [www.nebb.org](http://www.nebb.org)
- Noise Pollution Clearinghouse..... [www.nonoise.org](http://www.nonoise.org)
- North American Insulation Manufacturers Association (NAIMA)..... [www.naima.org](http://www.naima.org)
- Sheet Metal and Air Conditioning Contractors' National Association (SMACNA)..... [www.smacna.org](http://www.smacna.org)
- Testing, Adjusting and Balancing Bureau (TABB) ... [www.tabbcertified.org](http://www.tabbcertified.org)
- The Air-Conditioning, Heating, and Refrigeration Institute (AHRI)..... [www.ahrinet.org](http://www.ahrinet.org)
- Vibration Institute..... [www.vi-institute.org](http://www.vi-institute.org)