

CHAPTER 52

EVAPORATIVE COOLING

<i>General Applications</i>	52.1	<i>Industrial Applications</i>	52.11
<i>Indirect Evaporative Cooling Systems for</i>		<i>Other Applications</i>	52.14
<i>Comfort Cooling</i>	52.2	<i>Control Strategy to Optimize Energy Recovery</i>	52.15
<i>Booster Refrigeration</i>	52.8	<i>Air Cleaning and Sound Attenuation</i>	52.15
<i>Residential or Commercial Cooling</i>	52.10	<i>Economic Factors</i>	52.17
<i>Exhaust Required</i>	52.10	<i>Psychrometrics</i>	52.17
<i>Two-Stage Cooling</i>	52.11	<i>Entering Air Considerations</i>	52.18

EVAPORATIVE cooling is energy-efficient, environmentally friendly, and cost-effective in many applications and all climates. Applications range from comfort cooling in residential, agricultural, commercial, and institutional buildings, to industrial applications for spot cooling in mills, foundries, power plants, and other hot environments. Several types of apparatus cool by evaporating water directly in the airstream, including (1) direct evaporative coolers, (2) spray-filled and wetted-surface air washers, (3) sprayed-coil units, and (4) humidifiers. Indirect evaporative cooling equipment combines the evaporative cooling effect in a secondary airstream with a heat exchanger to produce cooling without adding moisture to the primary airstream.

Direct evaporative cooling reduces the dry-bulb temperature and increases the relative humidity of the air. It is most commonly applied to dry climates or to applications requiring high air exchange rates. Innovative schemes combining evaporative cooling with other equipment have resulted in energy-efficient designs.

When temperature and/or humidity must be controlled within narrow limits, heat and mechanical refrigeration can be combined with evaporative cooling in stages. Evaporative cooling equipment, including unitary equipment and air washers, is covered in Chapter 41 of the 2012 *ASHRAE Handbook—HVAC Systems and Equipment*.

1. GENERAL APPLICATIONS

Cooling

Evaporative cooling is used in almost all climates. The wet-bulb temperature of the entering airstream limits direct evaporative cooling. The wet-bulb temperature of the secondary airstream limits indirect evaporative cooling.

Design wet-bulb temperatures are rarely higher than 25°C, making direct evaporative cooling economical for spot cooling, kitchens, laundries, agricultural, and industrial applications. In regions with lower wet-bulb temperatures, evaporative cooling can be effectively used for comfort cooling, although some climates may require mechanical refrigeration for part of the year.

Indirect applications lower the air wet-bulb temperature and can produce leaving dry-bulb temperatures that approach the wet-bulb temperature of the secondary airstream. Using room exhaust as secondary air or incorporating precooled air in the secondary airstream could lower the wet-bulb temperature of the secondary air and further enhances the cooling capability of the indirect evaporative cooler.

Direct evaporative cooling is an adiabatic exchange of energy. Heat must be added to evaporate water. The air into which water is evaporated supplies the heat; thus, the dry-bulb temperature is lowered and the moisture content increases. The amount of heat removed from the air equals the amount of heat absorbed by the water evaporated as heat

of vaporization. If water is recirculated in the direct evaporative cooling apparatus, the water temperature in the reservoir approaches the wet-bulb temperature of the air entering the process. By definition, no heat is added to, or extracted from, an adiabatic process; the initial and final conditions fall on a line of constant wet-bulb temperature, which nearly coincides with a line of constant enthalpy.

The maximum reduction in dry-bulb temperature is the difference between the entering air dry- and wet-bulb temperatures. If air is cooled to the wet-bulb temperature, it becomes saturated and the process would be 100% effective. **Effectiveness** is the depression of the dry-bulb temperature of the air leaving the apparatus divided by the difference between the dry- and wet-bulb temperatures of the entering air. Theoretically, adiabatic direct evaporative cooling is less than 100% effective, although evaporative coolers are 85 to 95% (or more) effective.

When a direct evaporative cooling unit alone cannot provide desired conditions, several alternatives can satisfy application requirements and still be energy-effective and economical to operate. The recirculating water supplying the direct evaporative cooling unit can be increased in volume and chilled by mechanical refrigeration to provide lower leaving wet- and dry-bulb temperatures and lower humidity. Compared to the cost of using mechanical refrigeration only, this arrangement reduces operating costs by as much as 25 to 40%. Indirect evaporative cooling applied as a first stage, upstream from a second, direct evaporative stage, reduces both the entering dry- and wet-bulb temperatures before the air enters the direct evaporative cooler. Indirect evaporative cooling may save as much as 60 to 75% or more of the total cost of operating mechanical refrigeration to produce the same cooling effect. Systems may combine indirect evaporative cooling, direct evaporative cooling, heaters, and mechanical refrigeration, in any combination.

The psychrometric chart in [Figure 1](#) illustrates what happens when air is passed through a direct evaporative cooler. In the example shown, assume an entering condition of 35°C db and 24°C wb. The initial difference is $35 - 24 = 11$ K. If the effectiveness is 80%, the depression is $0.80 \times 11 = 8.8$ K db. The dry-bulb temperature leaving the direct evaporative cooler is $35 - 8.8 = 26.2$ °C. In the adiabatic evaporative cooler, only part of the water recirculated is assumed to evaporate and the water supply is recirculated. The recirculated water reaches an equilibrium temperature approximately the same as the wet-bulb temperature of the entering air.

The performance of an indirect evaporative cooler can also be shown on a psychrometric chart ([Figure 1](#)). Many manufacturers define effectiveness similarly for both direct and indirect evaporative cooling equipment. With indirect evaporative cooling, the cooling process in the primary airstream follows a line of constant moisture content (constant dew point). Indirect evaporative cooling effectiveness is the dry-bulb depression in the primary airstream divided by the difference between the entering dry-bulb temperature of the primary airstream and the entering wet-bulb temperature of the secondary air. Depending on heat exchanger design and relative

The preparation of this chapter is assigned to TC 5.7, Evaporative Cooling.

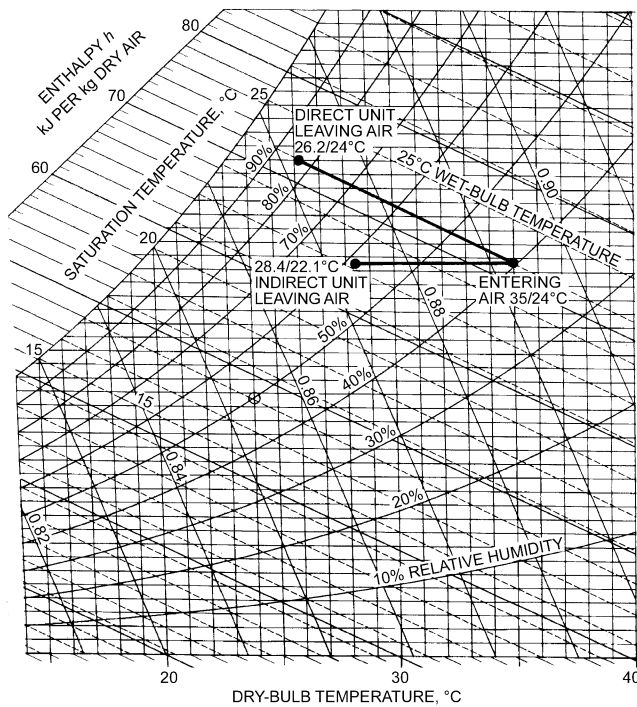

Fig. 1 Psychrometrics of Evaporative Cooling

quantities of primary and secondary air, effectiveness ratings may be as high as 85%.

Assuming 60% effectiveness, and assuming both primary and secondary air enter the apparatus at the outdoor condition of 35°C db and 24°C wb, the dry-bulb depression is $0.60(35 - 24) = 6.6$ K. The dry-bulb temperature leaving the indirect evaporative cooling process is $35 - 6.6 = 28.4$ °C. Because the process cools without adding moisture, the wet-bulb temperature is also reduced. Plotting on the psychrometric chart shows that the final wet-bulb temperature is 22.1°C. Because both wet- and dry-bulb temperatures in the indirect evaporative cooling process are reduced, indirect evaporative cooling can substitute for part of the refrigeration load.

Humidification

Air can be humidified with a direct evaporative cooler by three methods: (1) using recirculated water without prior treatment of the air, (2) preheating the air and treating it with recirculated water, or (3) heating recirculated water. Air leaving an evaporative cooler used as either a humidifier or a dehumidifier is substantially saturated when in operation. Usually, the spread between leaving dry- and wet-bulb temperatures is less than 1 K. The temperature difference between leaving air and leaving water depends on the difference between entering dry- and wet-bulb temperatures and on certain physical features, such as the length and height of a spray chamber, cross-sectional area and depth of the wetted media used, quantity and velocity of air, quantity of water, and spray pattern. In any direct evaporative humidifier installation, air should not enter with a dry-bulb temperature of less than 4°C; otherwise, the water may freeze.

Recirculated Water. Except for the small amount of energy added by shaft work from the recirculating pump and the small amount of heat leakage through the unit enclosure, evaporative humidification is strictly adiabatic. As the recirculated liquid evaporates, its temperature approaches the thermodynamic wet-bulb temperature of the entering air.

The airstream cannot be brought to complete saturation, but its state point changes adiabatically along a line of constant wet-bulb temperature. Typical saturation or humidifying effectiveness of various air washer spray arrangements is between 50 and 98%. The degree of saturation depends on the extent of contact between air and water. Other conditions being equal, low-velocity airflow is conducive to higher humidifying effectiveness.

Preheated Air. Preheating air increases both the dry- and wet-bulb temperatures and lowers the relative humidity; it does not, however, alter the humidity ratio (i.e., mass ratio of water vapor to dry air) or dew-point temperature of the air. At a higher wet-bulb temperature, but with the same humidity ratio, more water can be absorbed per unit mass of dry air in passing through the direct evaporative humidifier. Analysis of the process that occurs in the direct evaporative humidifier is the same as that for recirculated water. The desired conditions are achieved by heating to the desired wet-bulb temperature and evaporatively cooling at constant wet-bulb temperature to the desired dry-bulb temperature and relative humidity. Relative humidity of the leaving air may be controlled by (1) bypassing air around the direct evaporative humidifier or (2) reducing the number of operating spray nozzles or the area of media wetted.

Heated Recirculated Water. Heating humidifier water increases direct evaporative humidifier effectiveness. When heat is added to the recirculated water, mixing in the direct evaporative humidifier may still be modeled adiabatically. The state point of the mixture should move toward the specific enthalpy of the heated water. By raising the water temperature, the air temperature (both dry- and wet-bulb) may be raised above the dry-bulb temperature of entering air. The relative humidity of leaving air may be controlled by methods similar to those used with preheated air.

Dehumidification and Cooling

Direct evaporative coolers may also be used to cool and dehumidify air. If the entering water temperature is cooled below the entering wet-bulb temperature, both the dry- and wet-bulb temperatures of the leaving air are lowered. Dehumidification results if the leaving water temperature is maintained below the entering air dew point. Moreover, the final water temperature is determined by the sensible and latent heat absorbed from the air and the amount of circulated water, and it is 0.5 to 1 K below the final required dew-point temperature.

The air leaving a direct evaporative cooler being used as a dehumidifier is substantially saturated. Usually, the spread between dry- and wet-bulb temperatures is less than 0.5 K. The temperature difference between leaving air and leaving water depends on the difference between entering dry- and wet-bulb temperatures and on certain design features, such as the cross-sectional area and depth of the media or spray chamber, quantity and velocity of air, quantity of water, and the water distribution.

Air Cleaning

Direct evaporative coolers of all types perform some air cleaning. See the section on Air Cleaning and Sound Attenuation for detailed information.

2. INDIRECT EVAPORATIVE COOLING SYSTEMS FOR COMFORT COOLING

Five types of indirect evaporative cooling systems are most commonly used for commercial, institutional, and industrial cooling applications. Figures 2 to 6 show schematics of these dry evaporative cooling systems.

Indirect evaporative cooling efficiency is measured by the approach of the outdoor air dry-bulb condition to either the room return air or scavenger outdoor air wet-bulb condition on the wet side of the air-to-air heat exchanger. The **wet-bulb depression efficiency (WBDE)** is expressed as follows:

$$WBDE = \frac{t_1 - t_2}{t_1 - t_3} \times 100$$

where

- t_1 = supply air inlet dry-bulb temperature, °C
- t_2 = supply air outlet dry-bulb temperature, °C
- t_3 = wet-side air inlet wet-bulb temperature, °C

The heat pipe air-to-air heat exchanger in Figure 2 uses a direct water spray from a recirculation sump on the wet side of the heat pipe tubes (Scofield and Taylor 1986). When either room return or scavenger outdoor air passes over the wet surface, outdoor air entering the building is dry-cooled and produces an approach to the wet-side wet-bulb temperature in the range of 60 to 80% WBDE for equal mass flow rates on both sides of the heat exchanger. The WBDE is a function of heat exchanger surface area, face velocity, and completeness of wetting achieved for the wet-side heat exchanger surface. Face velocities on the wet side are usually selected in the range of 2 to 2.3 m/s.

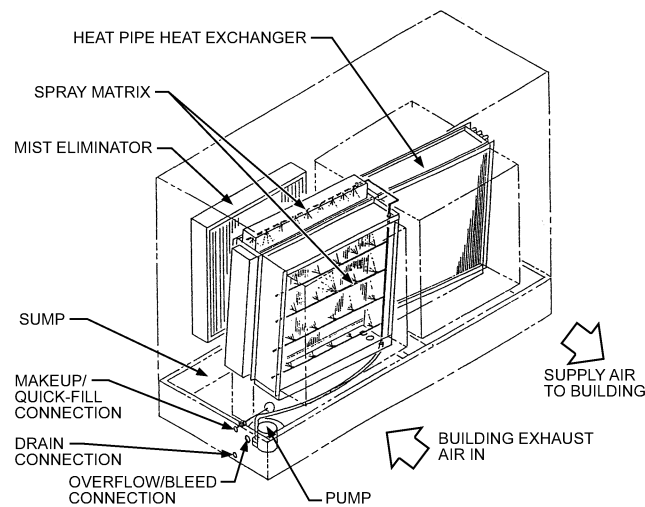

Fig. 2 Heat Pipe Air-to-Air Heat Exchanger with Sump Base

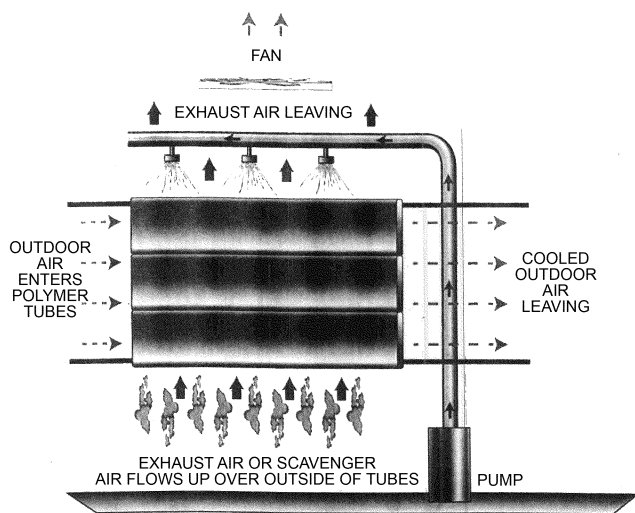

Fig. 3 Cross-Flow Plate Air-to-Air Indirect Evaporative Cooling Heat Exchanger (Munters)

Figure 3 illustrates an indirect evaporative cooling (IEC) heat exchanger. This cross-flow, polymer tube air-to-air heat exchanger uses a sump pump to circulate water to wet the outside of the horizontal heat exchanger tubes. A secondary air fan draws either building return or outdoor air vertically upward over the outside of the wetted tubes, causing evaporative cooling to occur. Outdoor air entering the building passes horizontally through the inside of the polymer tube bundle and is sensibly (dry) cooled. Latent and sensible cooling may occur in the outdoor makeup air stream if the secondary air's wet-bulb temperature is lower than the outdoor air's dew-point temperature.

The heat wheel (Figure 4) and the run-around coil (Figure 5) both use a direct evaporative cooling component on the cold side to enhance the dry-cooling effect on the makeup air side. The heat wheel (sensible transfer), when sized for 2.5 m/s face velocity with equal mass flows on both sides, has a WBDE around 60 to 70%. The run-around coil system at the same conditions produces a WBDE of 35 to 50%. The adiabatic cooling component is usually selected for an effectiveness of 85 to 95%. Water coil freeze protection is required in cold climates for the run-around coil loop.

Air-to-air heat exchangers that are directly wetted produce a closer approach to the cold-side wet-bulb temperature, all things being equal. First cost, physical size, and parasitic losses are also

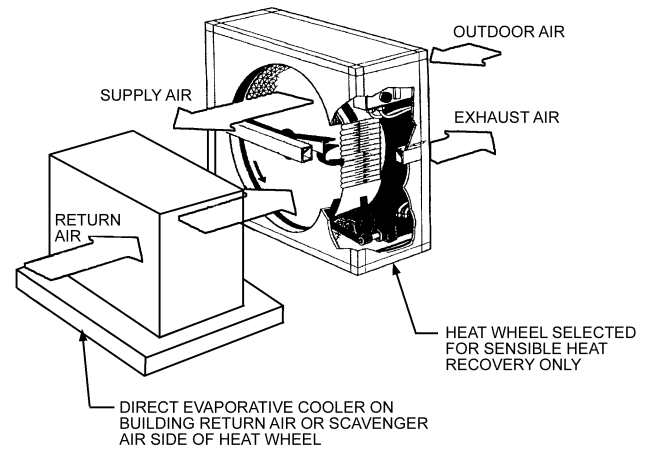

Fig. 4 Rotary Heat Exchanger with Direct Evaporative Cooling

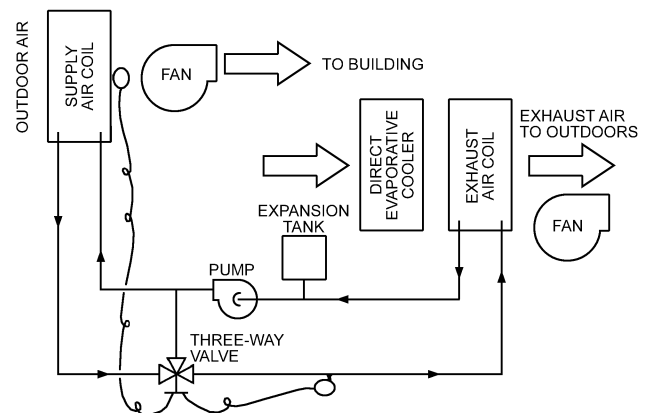

Fig. 5 Coil Energy Recovery Loop with Direct Evaporative Cooling

reduced by direct wetting of the heat exchanger. In applications having extremely hard makeup water conditions, using a direct evaporative cooling device in lieu of directly wetting the air-to-air heat exchanger may reduce maintenance costs and extend the useful life of the system.

All of the air-to-air heat exchangers (Figures 2 to 5) produce beneficial winter heat recovery when using building return air with the sprays or adiabatic cooling component turned off.

Figure 6 shows a cooling-tower-to-coil indirect evaporative cooling system with WBDE in the range of 50 to 75% (Colvin 1995). This system is sometimes referred as a water-side economizer. The cooling tower is selected for a close approach to the ambient wet-bulb temperature, with sump water from the tower then pumped to precooling coils in an air-handling unit. Provision for a plate-and-frame heat exchanger or water filtration to remove solids from sump water is needed, and water coils may need to be

cleanable. Freeze protection of the water coil loop is required in cold climates. No winter heat recovery is available with this design.

Table 1 gives the designer some performance predictions and application limits that may be helpful in determining the indirect evaporative cooling system that best solves the design problem at hand. If winter heat recovery is a priority, the heat wheel system may provide the quickest payback. Runaround coil systems are applied where supply air and exhaust air ducts are remote from each other. The heat pipe adapts well to high-volume air-handling systems where cooling energy reduction is the priority. The plate heat exchanger fits smaller-volume systems with high cooling requirements but with lower winter heat recovery potential. Des Champs and Dunnivant (2014) give additional information on air-side economizers using direct and indirect evaporative cooling in data centers.

Table 1 Indirect Evaporative Cooling Systems Comparison

System Type ^a	WBDE, ^b %	Heat Recovery Efficiency, %	Wet-Side Air ΔP , Pa	Dry-Side Air ΔP , Pa	Pump power, W per 4720 L/s	Parasitic Loss Range, ^c W/3517 W of Cooling	Equipment Cost Range, ^f US \$ per L/s	Notes
Cooling tower to coil	40 to 60	NA	NA	99.5 to 174.1	Varies	Varies	1.06 to 2.12	Best for serving multiple AHUs from a single cooling tower. No winter heat recovery.
Crossflow plate	60 to 85	40 to 50	174.2 to 248.8	99.5 to 174.1	74.6 to 149.2	120 to 200	2.54 to 3.60	Most cost-effective for lower airflows. Some cross contamination possible. Low winter heat recovery.
Heat pipe ^c	65 to 75	50 to 60	174.2 to 248.8	124.4 to 174.1	149.2 to 298.4	150 to 259	3.18 to 5.30	Most cost-effective for large airflows. Some cross contamination possible. Medium winter heat recovery.
Heat wheel ^d	60 to 70	70 to 80	149.3 to 223.9	99.5 to 161.7	74.6 to 149.2	200 to 300	3.18 to 5.30	Best for high airflows. Some cross contamination. Highest winter heat recovery rates.
Runaround coil ^b	35 to 50	40 to 60	149.3 to 199.0	99.5 to 161.7	Varies	> 350	2.12 to 4.24	Best for applications where supply and return air ducts are separated. Lowest summer WBDE.

WBDE = wet-bulb depression efficiency

Notes:

^aAll air-to-air heat exchangers have equal mass flow on supply and exhaust sides.

^bPlate and heat pipe are direct spray on exhaust side. Heat wheel and runaround coil systems use 90% WBDE direct evaporative cooling media on exhaust air side.

^cAssumes six-row heat pipe, 2.3 mm fin spacing, with 2.54 m/s face velocity on both sides.

^dAssumes 2.54 m/s face velocity. Parasitic loss includes wheel rotational power.

^eIncludes air-side static pressure and pumping penalty.

^fExcludes cooling tower cost and assumes less than 60 m piping between components.

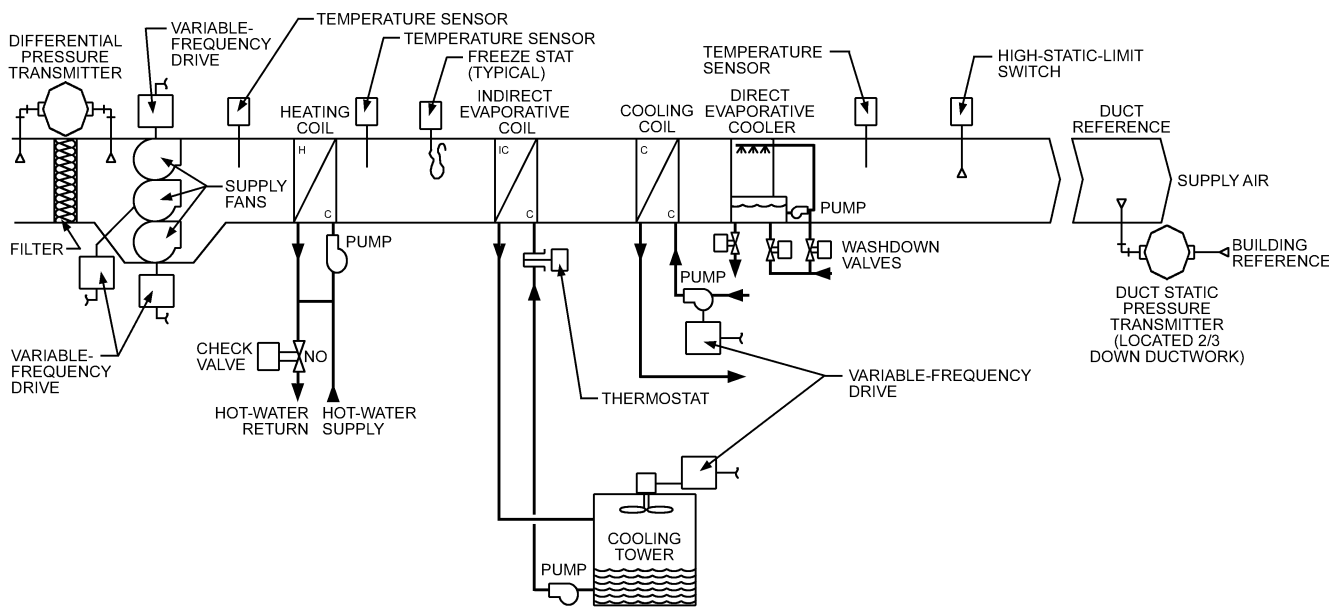

Fig. 6 Cooling-Tower-to-Coil Indirect Evaporative Cooling

Indirect Evaporative Cooling Controls

Where the heat exchanger is directly wetted, a water hardness monitor for the recirculation water sump is recommended. Water hardness should be kept within 200 to 500 parts per million (ppm) to minimize plating out of dissolved solids from the sump water. To maintain its set point, the hardness monitor may initiate a sump dump cycle when it detects increased water hardness. In addition, the sump should have provisions for a fixed bleed so that extra makeup water is continuously introduced to dilute dissolved solids left behind when water evaporates from the wetted heat exchanger surface. Sumps should always be drained at the end of a duty cycle and refilled the next day when the system is turned on. For rooftop applications, sumps should be drained for freeze protection during low ambient temperatures.

Air-side control for a cooling system with a 13°C supply air set point may be set up as follows. The heat exchanger's wet-side sprays or indirect evaporative cooling component should be activated whenever ambient dry-bulb temperatures exceed 18°C, if room return air is used on the wet side of the air-to-air heat exchanger. Air-conditioned buildings have a stable return air wet-bulb condition in the range of 15.5 to 18°C. Valuable precooling of outdoor air may be achieved when ambient dry-bulb temperatures exceed the return air wet-bulb condition.

Where outdoor air is used on the cold-air side of the heat exchanger, cooling may begin at ambient temperatures above 13°C, because the wet-bulb condition of outdoor air is always lower than its dry-bulb condition.

Parasitic losses generated by the heat exchanger static pressure penalty to supply and return air fans and by the water pump need to be evaluated. These losses may be mitigated by opening bypass dampers around the heat exchanger for pressure relief and shutting off the pump in the ambient temperature range of 13 to 18°C db. Where outdoor air is used on the wet side (scavenger air) of an air-to-air heat exchanger, this temperature range may be reduced somewhat. Comparing the energy penalty to the precooling energy avoided determines the optimum range of ambient conditions for this control strategy.

For variable-air-volume (VAV) supply and return fan systems, the static penalty reduces by the square of the airflow reduction from full design flow at summer peak design condition. As airflow rates decrease across an air-to-air heat exchanger, the WBDE increases, thereby providing better precooling. Where scavenger outdoor air is used for indirect evaporative cooling, the wet-side airflow rate is usually constant volume.

Winter heat recovery may be initiated at ambient temperatures below the 13°C supply air set point. Where building return air is used with an air-to-air heat exchanger, the 21 to 24°C return air condition is used to preheat makeup air for the building. For a VAV supply air system, Figure 7 shows the increased ventilation potential of a heat pipe air-to-air heat exchanger that uses face and bypass dampers on the supply air side to mix unheated outdoor air with preheated outdoor air to maintain the 13°C building supply air set point (Scofield and Bergman 1997). The heat pipe leaving air temperature may also be controlled with a tilt control (see Chapter 26 of the 2012 *ASHRAE Handbook—HVAC Systems and Equipment*). With a heat pipe economizer, a minimum outdoor air ventilation rate of 20% would not be breached until ambient temperatures dropped below -26°C.

Runaround coils control leaving supply air temperature with a three-way valve (see Figure 5). Because of their higher parasitic losses, these systems may require a wider range of ambient conditions where pressure-relief bypass dampers are open and the pump system shut down. Some projects limit activation of these recovery systems to ambient temperatures above 29°C to below 4°C.

Indirect/Direct Evaporative Cooling with VAV Delivery

Coupling indirect and direct evaporative cooling to a variable-air-volume (VAV) delivery system in arid climates can effectively eliminate requirements for mechanical refrigeration in many applications. Many cities in the western United States have summer design conditions suitable to deliver 13°C or lower supply air to a building using a 70% WBDE indirect and a 90% effective direct evaporative cooling system.

Figure 8 shows plan and elevation views of an air-handling unit using a sprayed heat pipe air-to-air heat exchanger and a wetted-media direct evaporative cooling section augmented by a final-stage chilled-water cooling coil (Scofield and Bergman 1997). The 70% indirect WBDE is achieved with a direct-sprayed heat pipe using a sump and a recirculation water system on the building return air side of the heat exchanger. The 90% effective direct evaporative cooling medium is split into two sections for two-stage cooling capacity control of the 13°C leaving air temperature. The direct evaporative cooling system also uses a sump and water recirculation. Supply-side heat pipe face and bypass dampers control the final supply air temperature (13°C) in both summer (when indirect sprays are on) and winter, to control the heat pipe's heat recovery capacity. Heat pipe dampers on both sides of the heat exchanger are powered to full open to mitigate system parasitic losses during ambient temperature conditions when the value of energy recovered is exceeded by the fan energy penalty. The recirculation damper is used for morning warm-up of the building and for blending building return air with preheated outdoor air during extreme cold ambient conditions (see Figure 7).

Table 2 uses ASHRAE bin weather data for the semi-arid climate of Sacramento, California, to illustrate potential cooling energy savings for a 4.7 m³/s VAV design that turns down to 2.4 m³/s at winter design (Scofield and Bergman 1997). Compared to a conventional-refrigeration cooling VAV design with a 25% minimum outdoor air economizer, the two-stage evaporative cooling system reduces peak cooling load by 49% while introducing 100% outdoor air. For a building duty cycle of 8760 h per year, the savings is 119 712 kWh, or a 60% reduction compared to the conventional air-side economizer system with mechanical cooling only. Within ambient bin conditions of 17°C db/12°C wb to 14°C db/11°C wb, there are 2376 cooling hours per year (27% of the annual cooling hours) where a 90% wet-bulb depression efficiency (WBDE) direct evaporative cooling system may be used for the 13°C supply air requirement without refrigeration.

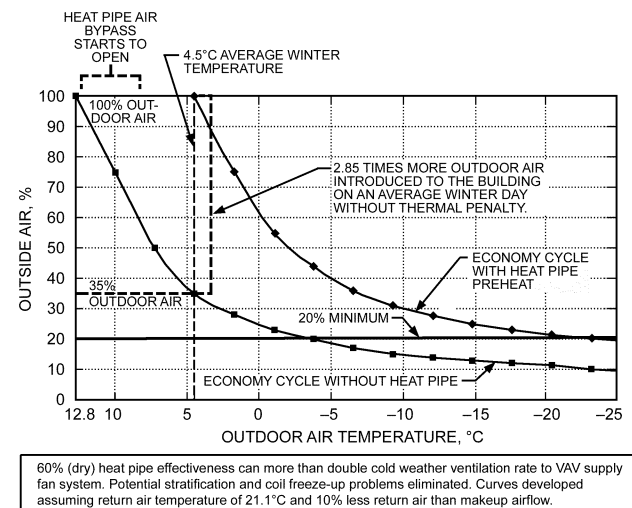
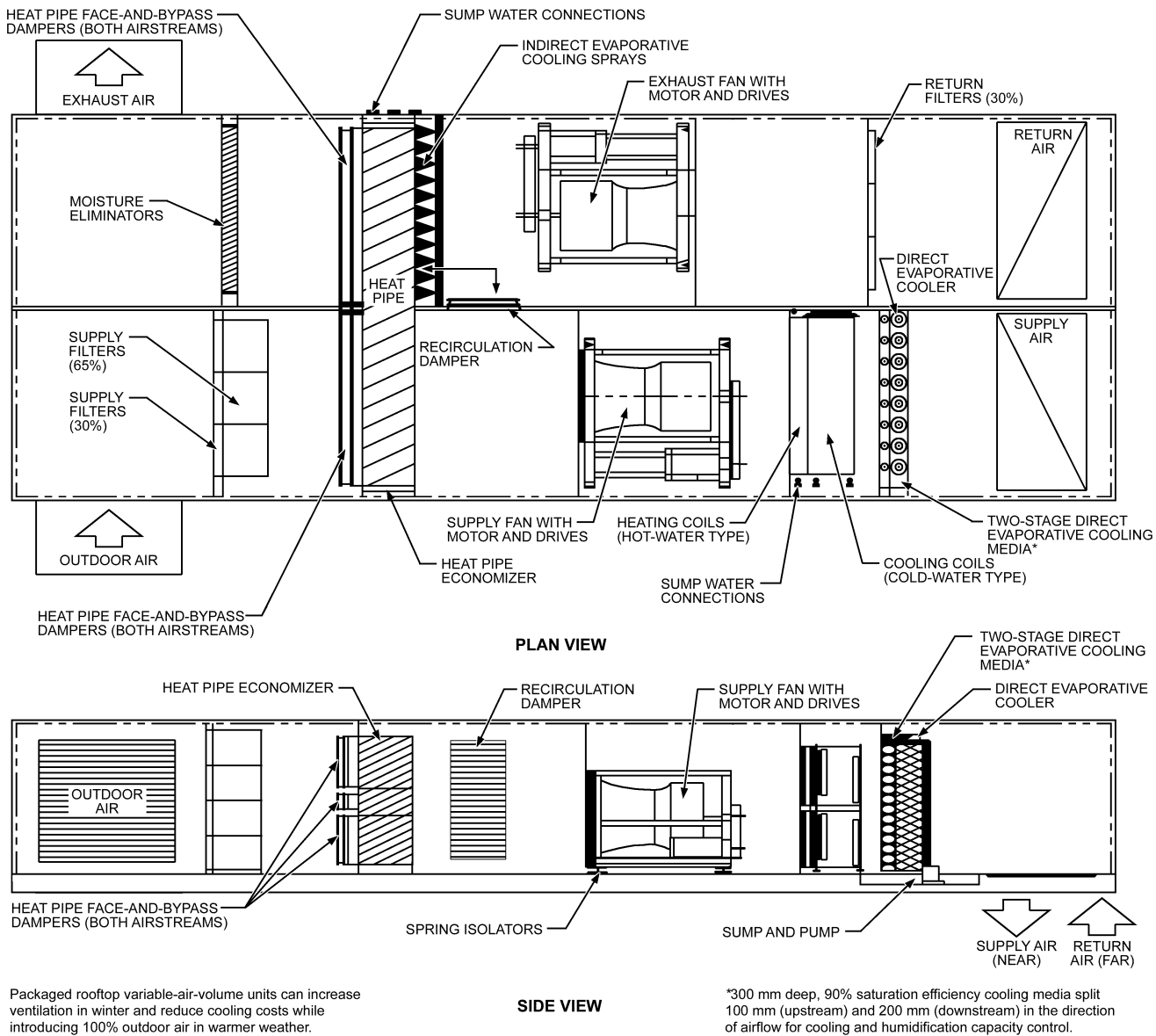

Fig. 7 Increased Winter Ventilation



Packaged rooftop variable-air-volume units can increase ventilation in winter and reduce cooling costs while introducing 100% outdoor air in warmer weather.

Fig. 8 Heat Pipe Air-Handling Unit

Figure 9 uses typical meteorological year (TMY) data for 14 cities in the western United States to illustrate the evaporative cooling annual refrigeration avoidance per 4.7 m/s of VAV supply air, compared to a 25% minimum outdoor air economizer (Scofield and Bergman 1997). For thermal energy storage (TES) applications, the two-stage evaporative cooling design may significantly reduce chiller plant storage capacity and refrigeration equipment first cost.

Benefits of this design in dry climates include the following:

- Indoor air quality is improved by using all outdoor air during cooling, and increased ventilation in winter through the heat pipe economizer (see Figure 7).
- Energy demand is in the range of 0.04 to 0.07 kW/kW of cooling, versus air-cooled refrigeration at 0.3 to 0.4 kW/kW.
- Peak building electrical cooling and gas heating demand requirements are reduced, especially for applications that require higher amounts of outdoor air.

- Because VAV pinchdown terminals may reduce their minimum airflow settings and comply with ASHRAE Standard 62.1, supply and return fan energy savings are possible in cooler weather when using an all-outdoor-air design.
- VAV turndown of fans during cooler ambient conditions decreases fan parasitic energy losses because of the evaporative cooling system components.
- VAV turndown increases the WBDE of both the air-to-air heat exchanger and direct evaporative cooling system.
- In semi-arid climates where a chilled-water final cooling stage is required, two-stage evaporative cooling allows central chilled-water plants to be turned off earlier in the fall and reactivated later in the spring. This results in significant maintenance and cooling energy cost savings.
- In cooler weather, resetting supply air down to 10°C and using only the direct evaporative cooler extends free cooling hours and reduces fan energy.

Table 2 Sacramento, California, Cooling Load Comparison

Outdoor Air db/wb, °C	VAV Supply, L/s	Hours Per Year ^d	100% Outdoor Air Indirect-Direct Evaporative Cooling				25% Outdoor Air Economizer			
			Indirect LAT db/wb, °C	Direct LAT db/wb, °C	Refrigeration, ^a kW	Refrigeration, ^b kWh	Mixed Air db/wb, °C	Refrigeration, ^a kW	Refrigeration, ^b kWh	
41.6/21.1	4720	7	25/15.5	16.5/15.5	49.9	349	28.3/18.8	102.7	719	
38.9/21.1	4602	59	24/16.2	17.0/16.2	61.2	3 611	27.7/18.8	99.5	5 871	
36.1/20.0	4425	144	23.3/15.6	16.4/15.6	49.2	7 085	27.2/18.3	91.1	13 118	
33.3/18.9	4277	242	22.3/15.0	15.7/15.0	40.4	9 777	26.1/18.4	83.4	20 183	
30.5/18.34	4130	301	21.6/15.2	15.8/15.2	36.9	11 107	25.5/18.4	78.4	23 598	
27.8/17.2	3983	397	20.6/14.8	15.4/14.8	33.4	13 260	24.9/17.7	71.4	28 346	
25/16.1	3835	497	20/14.2	14.8/14.2	23.6	11 729	25.2/17.4	64.4	32 007	
22.2/15.0	3687	641	18.8/13.9	14.4/13.9	18.6	11 923	22.2/15.0 ^b	45.4	29 101	
19.4/13.88	3540	821	18.3/13.3	13.8/13.3	13.7	11 248	19.4/13.88 ^b	31.6	25 944	
16.7/12.2	3393	1086	16.7/12.2	12.6/12.2	0	0	16.7/12.2 ^b	15.1	16 399 ^c	
13.8/11.1	3245	1290	13.8/11.1	11.4/11.1	0	0	13.8/11.1 ^b	3.5	4 515 ^c	
Total kWh =						80 089	Total kWh =			199 801

LAT = leaving-air temperature

Notes:

^aAmount of cooling required to reach 12.8°C db supply air requirements.

^bAmbient conditions when dampers for air-side economizer introduce 100% outdoor air in arid climates.

^cAmbient conditions when 90% saturation efficiency direct evaporative cooler may be used to eliminate refrigeration cooling.

Heat pipe bypass dampers should be open to minimize parasitic losses. Indirect water sprays should be off.

^dBin hours at each condition based on 24 h/day, 365 day/year duty cycle.

Table 3 Sacramento, California, Heat Recovery and Humidification

Outdoor Air db/wb, °C	VAV Supply, ^a L/s	Hours Per Year ^b	Heat Recovery Leaving Air db/wb, °C	Direct Evaporative Humidifier Leaving Air db/wb, ^c °C	Energy Savings, ^d W	Resultant Room rh
11.1/9.4	3097	1199	17.2/11.6	12.8/11.6	21 637	54%
8.4/6.7	2950	924	16.1/10.5	12.8/10.0	26 379	47%
5.1/4.4	2803	660	15/8.9	12.8/8.9	28 978	38%
3.9/2.2	2655	333	13.9/7.8	12.8/7.7	35 256	32%
0/-0.6	2507	116	12.8/6.1	OFF	38 338	25% ^e
-2.8/-3.3	2360	30	11.6/5.0	OFF	73 502	21% ^e

Source: Scofield and Bergman (1997).

^aVAV turndown airflow is assumed linear from summer design (4720 L/s) to winter design (2360 L/s).

^bBin hours at each condition based on 24 h/day, 365 days/year duty cycle.

^cHeat pipe overheats outdoor air to allow direct evaporative humidifier to add moisture.

^dRecirculated building heat used for preheating 100% outdoor air and increasing humidity levels.

^eAdditional heat is required or recirculation damper must open during these bin conditions, to maintain both acceptable 30% indoor relative humidity and reach the 12.79°C supply air set point.

- When using building return air, winter heat recovery provides increased outdoor air quantities during the period when fan turndown can result in loss of proper ventilation rates for VAV systems (see Figure 7).
- During mild winter daytime ambient conditions, the 100 mm deep wetted media section may be used for beneficial building humidification (see Table 3).

Beneficial Humidification

Areas with mild winter climates (e.g., the western U.S. coast) may use the heat available in building return air, through the air-to-air heat exchanger, to overheat supply air and add building humidification during the driest season of the year. The 100 mm section of direct evaporative cooling media (see Figure 8) is used in cool ambient conditions as a humidifier. Table 3 (Scofield and Bergman 1997) extends the Table 2 bin weather data for the Sacramento, California, site into winter ambient conditions. The table shows that 100% outdoor air may be introduced and humidity controlled between 54 and 32% for ambient conditions down to 2.8°C with a 60% heat pipe recovery effectiveness. There are only 146 bin hours below the 2.8°C ambient threshold during which the building recirculation air damper (see Figure 8) would have to open or additional heat be added with the hot-water coil to maintain the 12.8°C air delivery set point. The average winter temperature in Sacramento is 11.5°C.

Indirect Evaporative Cooling With Heat Recovery

In indirect evaporative cooling, outdoor supply air passes through an air-to-air heat exchanger and is cooled by evaporatively cooled air exhausted from the building or application. The two airstreams never mix or come into contact, so no moisture is added to the supply airstream. Cooling the building’s exhaust air results in a larger overall temperature difference across the heat exchanger and a greater cooling of the supply air. Indirect evaporative cooling requires only fan and water pumping power, so the coefficient of performance tends to be high. The principle of indirect evaporative cooling is effective in most air-conditioned buildings, because evaporative cooling is applied to exhaust air rather than to outdoor air.

Indirect evaporative cooling has been applied in a number of heat recovery applications (Mathur et al. 1993), such as plate heat exchangers (Scofield and DesChamps 1984; Wu and Yellot 1987), heat pipe exchangers (Mathur 1998; Scofield 1986), rotary regenerative heat exchangers, and two-phase thermosiphon loop heat exchangers (Mathur 1990). In residential air conditioning, the outdoor condensing unit can be evaporatively cooled to enhance performance (Mathur 1997; Mathur and Goswami 1995; Mathur et al. 1993). Indirect evaporative cooling with heat recovery is covered in detail in Chapter 26 of the 2012 ASHRAE Handbook—HVAC Systems and Equipment.

3. BOOSTER REFRIGERATION

Staged evaporative coolers can completely cool office buildings, schools, gymnasiums, sports facilities, department stores, restaurants, factory space, and other buildings. These coolers can control room dry-bulb temperature and relative humidity, even though one

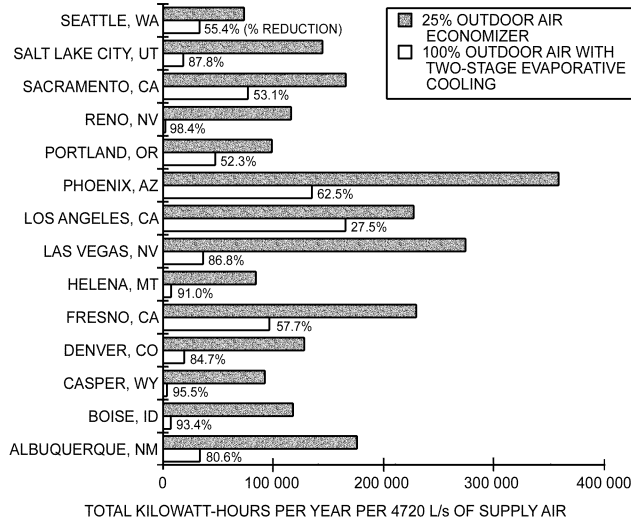

Note: Fourteen Western cities where indirect/direct evaporative cooling systems, using heat pipe (wet) indirect evaporative effectiveness of 70% and direct evaporative cooler saturation efficiency of 90%, can be used to introduce 100% outdoor air, with substantial reductions in kilowatt-hour cooling requirements compared to conventional 25% outdoor air economizer damper design. Kilowatt-hour totals for each system based on a 24 h/day, 365 day/year duty cycle and 4720 L/s VAV supply air. NREL hour by hour TMY data used to develop the kilowatt-hours listed. Fan heat not included.

Fig. 9 Refrigeration Reduction with Two-Stage Evaporative Cooling Design

stage is a direct evaporative cooling stage. In many cases, booster refrigeration is not required. Supple (1982) showed that even in higher-humidity areas with a 1% mean wet-bulb design temperature of 24°C, 42% of the annual cooling load can be satisfied by two-stage evaporative cooling. Refrigerated cooling need supply only 58% of the load.

Figure 10 shows indirect/direct two-stage performance for 16 cities in the United States. Performance is based on 60% WBDE of the indirect stage and 90% for the direct stage. Supply air temperatures (leaving the direct stage) at the 0.4% design dry-bulb mean coincident wet-bulb condition range from 13.4 to 22.4°C. Energy use ranges from 16.4 to 51.8%, compared to conventional refrigerated equipment.

Booster mechanical refrigeration provides indoor design comfort conditions regardless of the outdoor wet-bulb temperature without having to size the mechanical refrigeration equipment for the total cooling load. If the indoor humidity level becomes uncomfortable, the quantity of moisture introduced into the airstream must be limited to control room humidity. Where the upper relative humidity design level is critical, a life-cycle cost analysis favors a design with an indirect cooling stage and a mechanical refrigeration stage.

Figure 11 shows an air-handling unit design that uses building return air instead of outdoor air to develop the indirect (dry) evaporative cooling effect with a direct-sprayed, heat pipe, air-to-air, heat exchanger (Felver et al. 2001). The humid, cool air off the heat pipe is then used to reject the heat of refrigeration at a condenser coil downstream of the exhaust fan. The direct expansion (DX) cooling coil, the last component in the supply air, develops the final building supply air temperature when the two-stage evaporative cooling components cannot meet the design cooling requirements. Figure 12 shows the process points for both supply and exhaust airstreams, using the Stockton, California, ASHRAE 0.4% summer dry-bulb design ambient condition. Several benefits accrue from this evaporative cooling design:

City	Indirect/Direct Performance (Supply Air = 1.55 kJ/m ³)					
	Outdoor Air Design db/wb, °C	Indirect db/wb, °C	Supply Air db, °C	Two-Stage Sensible Capacity, W	Two-Stage Sensible EER	EUC, %
Los Angeles, CA	29.4/17.8	22.4/15.3	16.6	2303	8.2	30.5
San Francisco, CA	28.3/17.2	21.7/14.8	16.1	2421	8.6	29.0
Seattle, WA	29.4/18.3	22.8/16.1	17.3	2142	7.7	32.6
Albuquerque, NM	35.6/15.6	23.6/11.4	13.2	3080	11.3	22.3
Denver, CO	33.9/15.6	22.9/11.8	13.4	3018	11.3	22.3
Salt Lake City, UT	35.5/16.7	24.2/12.8	14.5	2774	10.1	24.7
Phoenix, AZ	43.3/21.1	30.0/16.9	18.8	1796	6.6	38.0
El Paso, TX	38.3/17.8	26.0/13.7	15.5	2549	9.4	36.8
Santa Rosa, CA	29.4/19.4	23.4/17.5	18.6	1834	6.6	37.7
Spokane, WA	33.3/16.7	23.3/13.2	14.7	2728	9.8	25.5
Boise, ID	35.6/17.2	24.6/13.4	15.1	2638	9.6	26.7
Billings, MT	33.9/17.2	23.9/13.9	15.4	2565	9.3	26.8
Portland, OR	32.2/19.4	24.6/16.9	18.2	1930	6.9	36.0
Sacramento, CA	37.8/20.6	27.4/17.2	18.8	1799	6.5	38.5
Fresno, CA	39.4/21.7	28.8/18.4	19.9	1528	5.6	44.5
Austin, TX	36.7/23.3	28.7/21.1	22.4	977	3.7	66.6

*At 20°C and 101.325 kPa

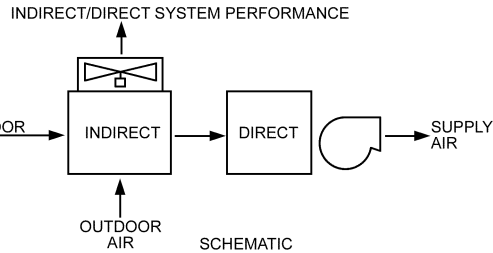

Notes:
 I/D effectiveness: Indirect = 60% or 0.6 (dry bulb – wet bulb);
 Direct = 90% or 0.9 (dry bulb – wet bulb).
 Outdoor air design condition: 0.4% dry bulb/mean coincident wet bulb (2013 ASHRAE Handbook—Fundamentals, Chapter 14).
 Fan heat is added to two-stage supply air dry bulb (0.5 K)
 Assume 0.6 W per L/s for the direct and 0.4 W per L/s* for the indirect section (200 W total). AC is 1000 W in all cases.
 Sensible capacity = 1.08 × L/s* × Δt. For AC, this is 2530 W in all cases, based on 11 K Δt.
 EER = energy efficiency ratio = watts cooling output per watt of electrical input. Comparison base to conventional refrigeration with 15.5°C supply air and 11 K temperature drop.
 Sensible EER = Sensible cooling capacity ÷ wattage.
 EUC = Energy Use Comparison to conventional refrigeration with EER = 8.6 (watt cooling per watt input).
 Psychrometric routines are calculated using site atmospheric pressure.

Fig. 10 Indirect/Direct Two-Stage System Performance

Evaporative Cooling

- Building return air has a more predictable and stable wet-bulb condition (15.5 to 18°C) than ambient air for use in generating the first stage of indirect (dry) evaporative cooling. Daytime absorption of moisture inside most buildings further enhances the first-stage cooling effect.
- Locating a DX condenser coil in sprayed exhaust off the heat pipe results in a more efficient rejection of refrigeration heat than a condenser coil located outdoors in the ambient air.
- Lower refrigeration condensing temperatures increase compressor capacity and compressor life, and reduce energy consumption.
- Central chilled-water plant or remote chiller installation and piping costs are eliminated.
- Evaporative cooling components provide back-up cooling capability in case of compressor failure. Figure 12 shows equilibrium conditions in the occupied area with indirect/direct evaporative cooling only at the design dry-bulb ambient condition.
- Peak refrigeration demand can be reduced 14 to 40% in California's semi-arid climate (Scofield 1994).
- Blow-through supply fan and draw-through exhaust fans provide:
 - Reduced supply fan heat addition for DX cooling system.
 - Reduced risk of cross contamination of supply air with exhaust air for hospital or laboratory applications.
 - Reduced fan noise breakout into building duct system.

There are several design considerations for the successful integration of DX refrigeration with two-stage evaporative cooling air-handling units, as shown in Figure 11.

For both constant-volume (CV) and variable-air-volume (VAV) units, the return air must closely match the supply airflow to ensure adequate heat rejection at the condenser coil. Buildings with large fixed-exhaust systems may not provide sufficient building return airflow for absorption of refrigeration heat at acceptable refrigerant condensing temperatures.

Secondary face-and-bypass dampers are required around the condenser coil for control of the refrigerant condensing pressure and temperature.

Note that peak refrigeration requirements always occur during the highest ambient humidity (dew-point design) conditions. In semi-arid climates, this design condition occurs during reduced summer ambient dry-bulb temperatures (Ecodyne Corp. 1980). Review of site ASHRAE dew-point design conditions (Chapter 14

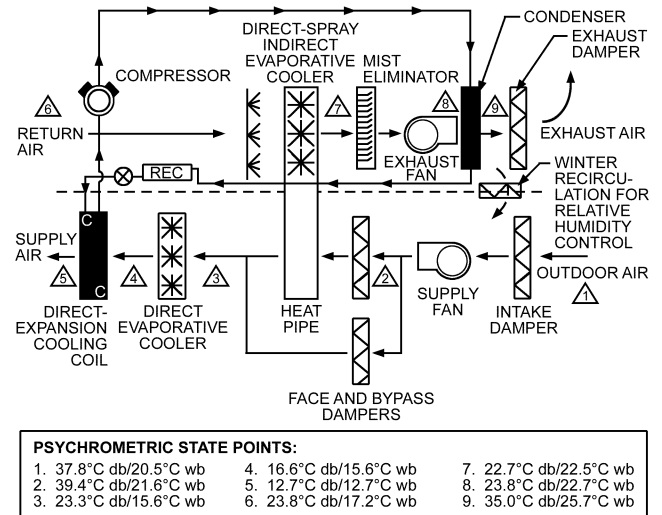

Fig. 11 Two-Stage Evaporative Cooling with Third-Stage Integral DX Cooling Design

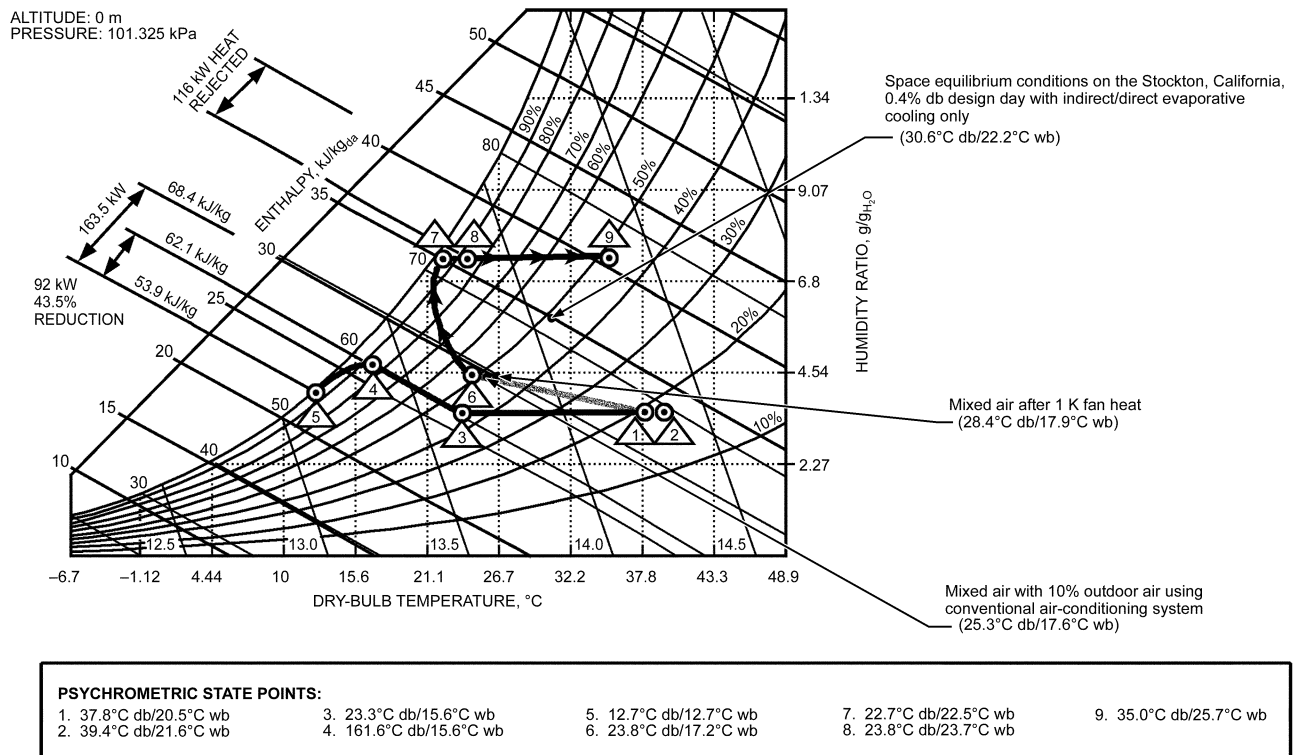

Fig. 12 Psychrometrics of 100% OA, Two-Stage Evaporative Cooling Design (9440 L/s Supply, 8496 L/s Return) Compared with 10% OA Conventional System Operating at Stockton, California, ASHRAE 0.4% db Design Condition

of the 2013 *ASHRAE Handbook—Fundamentals*) is required to determine the peak refrigeration cooling capacity needed to maintain the specified supply air temperature set point to the building.

4. RESIDENTIAL OR COMMERCIAL COOLING

In dry climates, evaporative cooling is effective at lower air velocities than those required in humid climates. Packaged direct evaporative coolers are used for residential and commercial application. Cooler capacity may be determined from standard heat gain calculations (see Chapters 17 and 18 of the 2013 *ASHRAE Handbook—Fundamentals*).

Detailed calculation of heat load, however, is usually not economically justified. Instead, one of several estimates gives satisfactory results. In one method, the difference between dry-bulb design temperature and coincident wet-bulb temperature multiplied by 10 is equal to the number of seconds needed for each air change. This or any other arbitrary method for equating cooling capacity with airflow depends on a direct evaporative cooler effectiveness of 70 to 80%. Obviously, the method must be modified for unusual conditions such as large unshaded glass areas, uninsulated roof exposure, or high internal heat gain. Also, such empirical methods make no attempt to predict air temperature at specific points; they merely establish an air quantity for use in sizing equipment.

Example 1. An indirect evaporative cooler is to be installed in a 15 by 24.4 m one-story office building with a 3 m ceiling and a flat roof. Outdoor design conditions are assumed to be 35°C db and 18.3°C wb. The following heat gains are to be used in the design:

	Heat Gains, kW
All walls, doors, and roof	23.0
Glass area	1.7
Occupants (sensible load)	5.0
Lighting	18.4
Total sensible heat load	48.1
Total latent load (occupants)	6.2
Total heat load	54.3

Find the required air quantity, the temperature and humidity ratio of the air leaving the cooler (entering the office), and the temperature and humidity ratio of the air leaving the office.

Solution: A temperature rise of 5 K in the cooling air is assumed. The airflow rate that must be supplied by the indirect evaporative cooler may be found from the following equation:

$$Q_{ra} = \frac{q_s}{\rho c_p (t_1 - t_s)} = \frac{48.1}{1.2 \times 5} = 8.0 \text{ m}^3/\text{s} \quad (1)$$

where

- Q_{ra} = required airflow, m³/s
- q_s = instantaneous sensible heat load, kW
- t_1 = indoor air dry-bulb temperature, °C
- t_s = room supply air dry-bulb temperature, °C
- ρc_p = density times specific heat of air $\approx 1.2 \text{ kJ}/(\text{m}^3 \cdot \text{K})$

This air volume represents a 137 s ($15 \times 24.4 \times 3/8.0$) air change for a building of this size. The indirect evaporative air cooler is assumed to have a saturation effectiveness of 80%. This is the ratio of the reduction of the dry-bulb temperature to the wet-bulb depression of the entering air. The dry-bulb temperature of the air leaving the indirect evaporative cooler is found from the following equation:

$$t_2 = t_1 - \frac{e_h}{100} (t_1 - t') = 35 - \frac{80}{100} (35 - 18.3) = 21.6^\circ\text{C} \quad (2)$$

where

- t_2 = dry-bulb temperature of leaving air, °C
- t_1 = dry-bulb temperature of entering air, °C

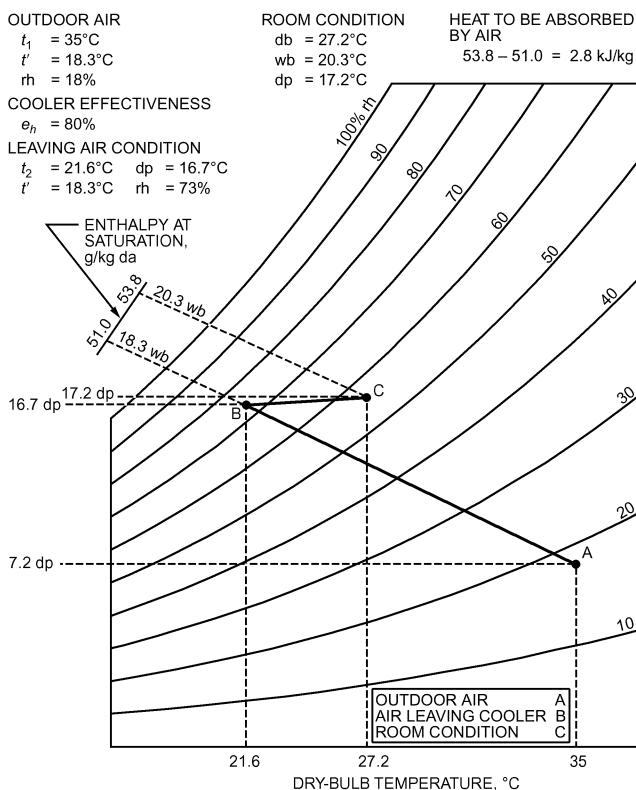

Fig. 13 Psychrometric Diagram for Example 1

- e_h = humidifying or saturating effectiveness, %
- t' = thermodynamic wet-bulb temperature of entering air, °C

From the psychrometric chart, the humidity ratio W_2 of the cooler discharge air is 11.85 g/kg_{da}. The humidity ratio W_3 of the air leaving the space being cooled is found from the following equation:

$$W_3 = \frac{q_e}{3.010 Q_{ra}} + W_2 \quad (3)$$

$$W_3 = \frac{6.2}{3.010 \times 8.0} + 11.85 = 12.11 \text{ g/kg (dry air)}$$

where q_e = latent heat load in kW.

The remaining values of wet-bulb temperature and relative humidity for the problem may be found from the psychrometric chart. Figure 13 illustrates the various relationships of outdoor air, supply air to the space, and discharge air.

The wet-bulb depression (WBD) method to estimate airflow gives the following result:

$$\text{WBD} \times 10 = (35 - 18.3) \times 10 = 167 \text{ s per air change}$$

$$Q_{ra} = \frac{\text{Volume}}{\text{Air change rate}} = \frac{15 \times 24.4 \times 3}{167} = 6.6 \text{ m}^3/\text{s}$$

Although not exactly alike, these two air volume calculations are close enough to select cooler equipment of the same size.

5. EXHAUST REQUIRED

If air is not exhausted freely, the increased static pressure will reduce airflow through the evaporative cooler. The result is a marked increase in the moisture and heat absorbed per unit mass of air leaving the evaporative cooler. Reduced airflow also reduces the air velocity in the room. The combination of these effects reduces the comfort level. Properly designed systems should have a maximum air velocity of 2.5 m/s through the exhaust. If the exhaust area

is not sufficient, a powered exhaust should be used. The amount of power depends on the total airflow and the amount of free or gravity exhaust. Some applications require that the powered exhaust capacity equal the cooler output.

6. TWO-STAGE COOLING

Two-stage coolers for commercial applications can extend the range of atmospheric conditions under which comfort requirements can be met, as well as reduce the energy cost. For the same design conditions, two-stage cooling provides lower cool-air temperatures, which reduces required airflow.

7. INDUSTRIAL APPLICATIONS

In factories with large internal heat loads, it is difficult to approach outdoor conditions during the summer simply by ventilating without using extremely large quantities of outdoor air. Both direct and indirect evaporative cooling may be used to reduce heat stress with less outdoor air. Evaporative cooling normally results in lower effective temperatures than ventilation alone, regardless of the ambient relative humidity.

Effective Temperature. Comfort cooling in air-conditioned spaces is usually based on providing space temperature and relative humidity conditions for human comfort without a draft. The effective temperature relates the cooling effects of air motion and relative humidity to the effect of conditioned (cooled) air. Figure 14 shows an effective temperature chart for air velocities from 0.1 to 3.5 m/s. Although the maximum velocity shown on the chart is 3.5 m/s, workers exposed to high-heat-producing operations may prefer air movement up to 20 m/s to offset the radiant heat effect of equipment. Because the normal working range of the chart is

approximately midway between the vertical dry- and wet-bulb scales, changes in either dry- or wet-bulb temperatures have similar effects on worker comfort. A reduction in either one decreases the effective temperature by about one-half of the reduction. Lines ED and CD on the chart illustrate this.

A condition of 35°C db and 24°C wb was chosen as the original state, because this condition is usually considered the summer design criterion in most areas. Reducing the temperature 8 K by evaporating water adiabatically provides an effective temperature reduction of 3 K for air moving at 0.1 m/s and a reduction of 5 K for air moving at 3.5 m/s, an improvement of 2 K.

The reduction in dry-bulb temperature through water evaporation increases the effectiveness of the cooling power of moving air in this example by 137%. On Line ED, the effective temperature varies from 28.5°C at 0.1 m/s to 26.5°C at 3.5 m/s with unconditioned air, whereas Line CD indicates an effective temperature of 25.5°C at 0.1 m/s and 21.5°C at 3.5 m/s with air cooled by a simple direct evaporative process. In the unconditioned case, increasing the air velocity from 0.1 to 3.5 m/s resulted in only a 2 K decrease in effective temperature. This contrasts with a 4 K decrease in effective temperature for the same range of air movement when the dry-bulb temperature was lowered by water evaporation. This demonstrates that direct evaporative cooling can provide a more comfortable environment regardless of geographical location.

Two methods are demonstrated to illustrate the environmental improvement that may be achieved with evaporative coolers. In one method, shown in Figure 15, temperature is plotted against time of day to illustrate effective temperature depression over time. Curve A shows ambient maximum dry-bulb temperature recordings. Curve B shows the corresponding wet-bulb temperatures. Curve C depicts the effective temperature when unconditioned air is moved over a person

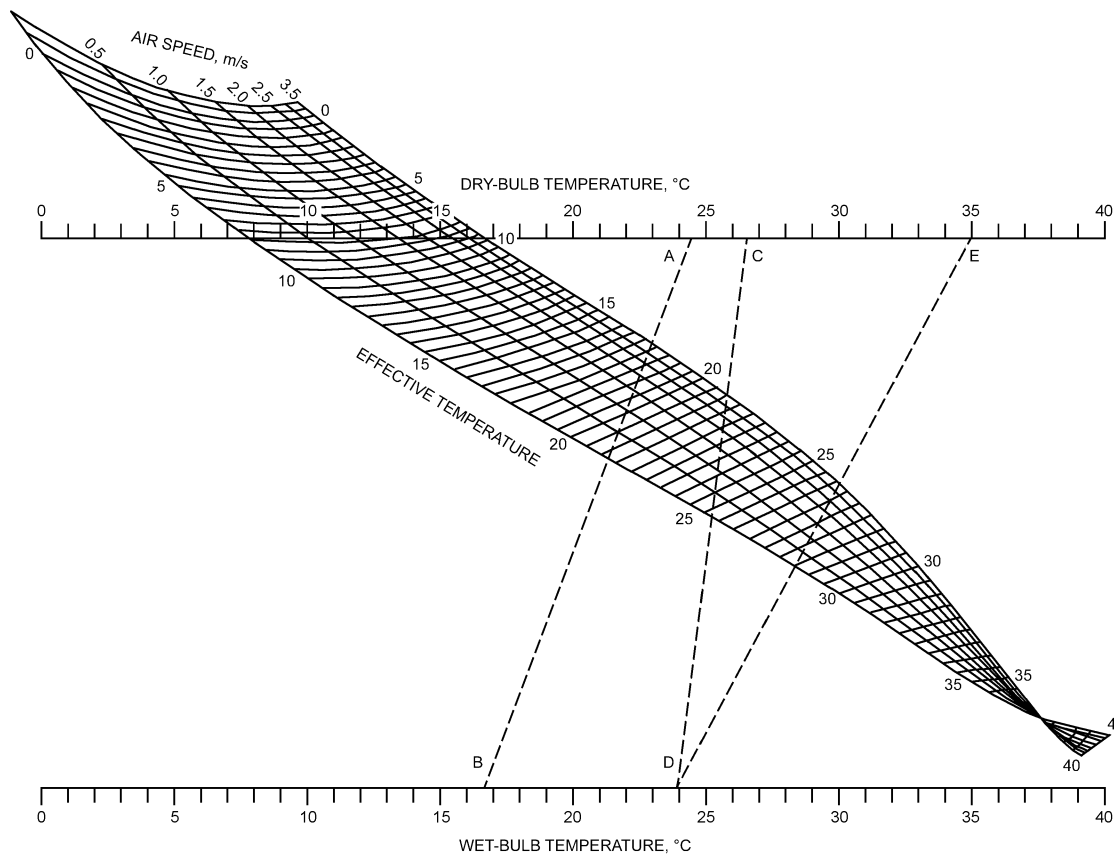

Fig. 14 Effective Temperature Chart

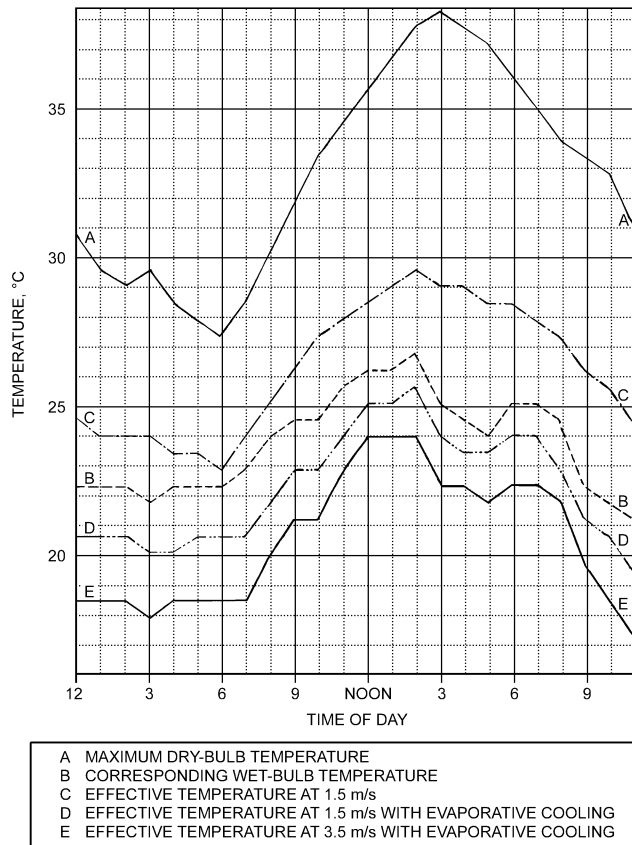

Fig. 15 Effective Temperature for Summer Day in Kansas City, Missouri (Worst-Case Basis)

at 1.5 m/s. Curve D illustrates air conditioned in an 80% effective direct evaporative cooler before being projected over the person at 1.5 m/s. Curve E shows the additional decrease in effective temperature with air velocities of 3.5 m/s. Although a maximum suggested effective temperature of 27°C is briefly exceeded with unconditioned air at 1.5 m/s (curve C), both the differential and total hours are substantially reduced from still-air conditions. Curves D and E illustrate that, in spite of the high wet-bulb temperatures, the in-plant environment can be continuously maintained below the suggested upper limit of 27°C effective temperature. This demonstration assumes that the combination of air velocity, duct length, and insulation between evaporative cooler and duct outlet is such that there is little heat transfer between air in ducts and warmer air under the roof.

Figure 16 illustrates another method of demonstrating the effect of using direct evaporative coolers by plotting effective comfort zones using ambient wet- and dry-bulb temperatures on a psychrometric chart (Crow 1972). The dashed lines show the expected improvement when using an 80% effective direct evaporative cooler.

Area Cooling

Both direct and indirect evaporative cooling may be used for area or spot cooling of industrial buildings. Both can be controlled either automatically or manually. In addition, evaporative coolers can supply tempered air during fall, winter, and spring. Gravity or power ventilators exhaust the air. Area cooling works well in buildings where personnel move about and workers are not subjected to concentrated, radiant heat sources. Area cooling may be used in either high- or low-bay industrial buildings, but may provide significant advantages in high-bay construction where cooling loads associated with roofs, lighting, and heat from equipment may be effectively

eliminated by taking advantage of stratification. When cooling an area, ductwork should be designed to distribute air to the lower 3 m of the space to ensure that cooler air is supplied to the workers.

Cooling requirements change from day to day and season to season, so if discharge grilles are used, they should be adjustable to prevent drafts. The horizontal blades of an adjustable grille can be adjusted so that air is discharged above workers' heads rather than directly on them. In some cases, the air volume can be adjusted, either at each outlet or for the entire system, in which case the exhaust volume may need to be varied accordingly.

Spot Cooling

Spot cooling is a more efficient use of equipment when personnel work in one spot. Cool air is brought to the spot at levels below 3 m, and may even be delivered from floor outlets. Duct height may depend on the location of other equipment in the area. For best results, air velocity should be kept low. Controls may be automatic or manual, with the fan often operating throughout the year. Workers are especially appreciative of spot cooling in hot environments, such as in chemical plants and die casting shops, and near glass-forming machines, billet furnaces, and pig and ingot casting.

When spot-cooling a worker, the air volume depends on the throw of the air jet, activity of the worker, and amount of heat that must be overcome. Air volumes can vary from 90 to 2400 L/s per worker, with target velocities ranging between 1 to 20 m/s. Outlets should be between 1.2 to 3 m from workstations to avoid entrainment of warm air and to effectively blanket workers with cooler air. Provisions should be made for workers to control the direction of air discharge, because air motion that is appropriate for hot weather may be too great for cool weather or even cool mornings. Volume controls may be required to prevent overcooling the building and to minimize excessive grille blade adjustment.

Spot cooling is useful in rooms with elevated temperatures, regardless of climatic or geographical location. When the dry-bulb temperature of the air is below skin temperature, convection rather than evaporation cools workers. In these conditions, a 27°C air-stream can provide comfort regardless of its relative humidity.

Cooling Large Motors

Electrical generators and motors are generally rated for a maximum ambient temperature of 40°C. When this temperature is exceeded, excessive temperatures develop in the electrical windings unless the load on the motor or generator is reduced. By providing evaporatively cooled air to the windings, this equipment may be safely operated without reducing the load. Likewise, transformer capacity can be increased using evaporative cooling.

The heat emitted by high-capacity electrical equipment may also be sufficient to raise the ambient condition to an uncomfortable level. With mill drive motors, an additional problem is often encountered with the commutator. If the air used to ventilate the motor is dry, the temperature rise through the motor results in a still lower relative humidity, at which the brush film can be destroyed, with unusual brush and commutator wear as well as the occurrence of dusting.

As a rule, a motor with a temperature rise of 14 K requires approximately 60 L/s of ventilating air per kilowatt of loss. If inlet air to the motor is 35°C, air leaving the motor would be 49°C. This average motor temperature of over 42°C is 2 K higher than it should be for the normal 40°C ambient. The same quantity of 35°C db inlet air at 24°C wb can be cooled by a direct evaporative cooler with a 97% saturation effectiveness. The resulting 31°C average motor temperature eliminates the need for special high-temperature insulation and improves the motor's ability to absorb temporary overloads. By comparison, an air quantity of 90 L/s is required if supplied by a cooler with 80% saturation effectiveness.

Figure 17 shows three basic arrangements for motor cooling. Air from the evaporative cooler may be directed on the motor windings,

or into the room, which requires an increased air volume to compensate for the building heat load. Operation of a direct evaporative cooler should be keyed to motor operation to ensure that (1) saturated or nearly saturated air is never introduced into a motor until it has had time to warm up, and (2) if more than one motor is served by a single system, air circulation through idle motors should be prevented.

Cooling Gas Turbine Engines and Generators

Combustion turbines used for electric power production are normally rated at 15°C. Their performance is greatly influenced by the compressor inlet air temperature because temperature affects air density and therefore mass flow. As ambient temperature increases, demand on electric utilities increases and the capacity of the combustion turbine decreases. Recovery of capacity because of inlet air cooling is approximately 0.2%/K (cooling). Direct and indirect evaporative cooling is beneficial to gas turbine performance in almost all climates because when the air is the hottest, it generally has the lowest relative humidity. Expected increases in output using direct evaporative cooling range from 5.8% in Albany, New York, to 14% in Yuma, Arizona. In addition to increasing gas turbine output, direct evaporative cooling also improves heat rate and reduces NO_x emissions.

For an installation of this type, the following precautions must be taken: (1) mist eliminators must be provided to stop entrainment of free moisture droplets, (2) coolers must be turned off at a temperature below 7°C to prevent icing, and (3) water quality must be monitored closely (Stewart 1999).

Process Cooling

In the manufacture of textiles and tobacco and in processes such as spray coating, the required accurate relative humidity control can be provided by direct evaporative coolers. For example, textile manufacturing requires relatively high humidity and the machinery load is heavy, so a split system is customarily used to introduce free moisture directly into the room. The air handled is reduced to approximately 60% of that normally required by an all-outdoor-air, direct evaporative cooler.

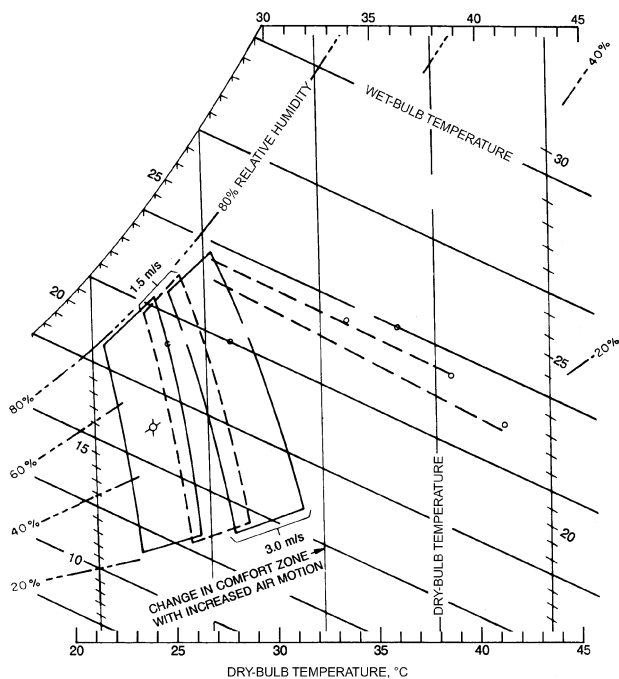

Fig. 16 Change in Human Comfort Zone as Air Movement Increases

Cooling Laundries

Laundries have one of the most severe environments in which direct evaporative air cooling is applied because heat is produced not only by the processing equipment, but by steam and water vapor as well. A properly designed direct evaporative cooler reduces the temperature in a laundry 3 to 6 K below the outdoor temperature. With only fan ventilation, laundries usually exceed the outdoor temperature by at least 5 K. Air distribution should be designed for a maximum throw of not more than 9 m. A minimum circulated velocity of 0.5 to 1 m/s should prevail in the occupied space. Ducts can be located to discharge the air directly onto workers in exceptionally hot areas, such as pressing and ironing departments. For these outlets, there should be some means of manual control to direct the air where it is desired, with at least 250 to 500 L/s at a target velocity of 3 to 4.5 m/s for each workstation.

Cooling Wood and Paper Products Facilities

Wood-processing plants and paper mills are good applications for evaporative cooling because of the high temperatures and gases associated with wood-processing equipment. Wood dust should be kept out of the recirculation sumps of evaporative coolers, because the dust contains microorganisms and worm larvae that will grow in sumps.

Because of the types of gases and particulates present in most paper plants, water-cooled systems are preferred over air-cooled systems. The most prevalent contaminant is wood dust. Chlorine gas, caustic soda, sulfur, hydrogen sulfide, and other compounds are also serious problems, because they accelerate the corrosion of steel and yellow metals. With more efficient air scrubbing, ambient air quality in and about paper mills has become less corrosive, allowing use of equipment with well-analyzed and properly applied coatings on coils and housings. Phosphor-free brazed coil joints should be used in areas where sulfur compounds are present.

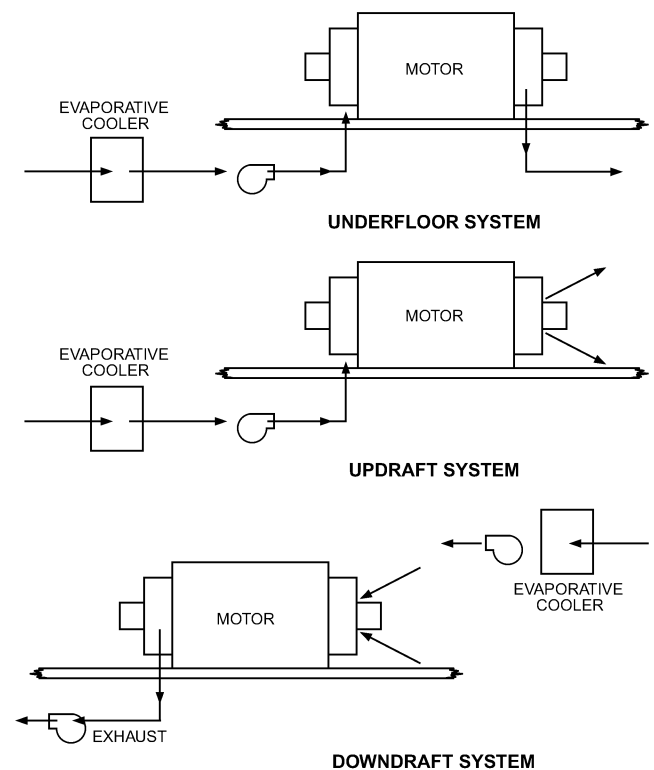

Fig. 17 Arrangements for Cooling Large Motors

Heat is readily available from processing operations and should be used whenever possible. Most plants have good-quality hot water and steam, which can be readily geared to unit heater, central station, or reheat use. Newer plant air-conditioning methods, including evaporative cooling, that use energy-conservation techniques (such as temperature stratification) lend themselves to this type of large structure. Chapter 26 has further information on air-conditioning of paper facilities.

8. OTHER APPLICATIONS

Cooling Power-Generating Facilities

An appropriate air-cooling system can be selected once preliminary heating and cooling loads are determined and criteria are established for temperature, humidity, pressure, and airflow control. The same considerations for selection apply to power-generating facilities and industrial facilities.

Cooling Mines

Chapter 29 describes evaporative cooling methods for mines.

Cooling Animals

The design criteria for farm animal environments and the need for cooling animal shelters are discussed in Chapter 24. Direct evaporative cooling is ideally suited to farm animal shelters because 100% outdoor air is used. Fresh air removes odors and reduces the harmful effects of ammonia fumes. At night and in the spring and fall, direct evaporative cooling can also be used for ventilation.

Equipment should be sized to change the air in the shelter in 1 to 2 min, assuming the ceiling height does not exceed 3 m. This flow rate usually keeps the shelter at or below 27°C. In addition, conditions can be improved with portable or packaged spot coolers.

For poultry housing, most applications require an air change every 0.75 to 1.5 min, with the majority at 1 min. Placing the fans at the ends or the center of the house, with the direct evaporative cooler located at the opposite end, creates a tunnel ventilation system with an air velocity of 1.5 to 2.5 m/s. Fans are generally selected for a total pressure drop of 30 Pa, which means that the direct evaporative cooling media cannot have a pressure drop in excess of 20 Pa. Thus, to prevent an inadequate volume of air being pulled through the poultry house, the designer must carefully size the media selected.

Using direct evaporative cooling for poultry broiler houses decreases bird mortality, improves feed conversion ratio, and increases the growth rate. Poultry breeder houses are evaporatively cooled to improve egg production and fertility during warm weather. Evaporative cooling of egg layers improves feed conversion, shell quality, and egg size. When the ambient outdoor temperature exceeds 38°C, evaporative cooling is often the only way to keep a flock alive. Direct evaporative cooling is also used to cool swine farrowing and gestation houses to improve production.

Produce Storage Cooling

Potatoes. Direct evaporative cooling for bulk potato storage should pass air directly through the pile. The ventilation and cooling system should provide 10 to 15 mL/s per kilogram of potatoes. Average potato density is 720 kg/m³ in the pile. Pile depths range from 3.5 to 6 m, which creates a static pressure of 40 to 60 Pa. Ventilation consists of fresh air inlets, return air openings, exhaust air openings, main air ducts, and lateral ducts with holes or slots to distribute air uniformly through the pile. Distribution ducts should be placed no farther apart than 80% of the potato pile depth, and should extend to within 450 mm of the storage walls. Ducts, the direct evaporative cooling media, and any refrigeration coils cause a static pressure ranging from 120 to 250 Pa. Typically the total static pressure ranges from 200 to 300 Pa, depending on the equipment. Air

speed through each of the openings in the ventilation/cooling system should be as listed in Table 4.

Direct evaporative cooling media should be 90 to 95% effective, depending on the climate. In arid regions, 95% effective media are recommended. In more humid climates, such as in the midwestern and eastern United States, 90% effective media are commonly used. Air speed through the media should be 2.5 to 2.8 m/s to ensure high pad efficiency with low static-pressure penalty.

For more information, see Chapter 37 of the 2014 *ASHRAE Handbook—Refrigeration*.

Apples. Direct evaporative cooling for apple storage without refrigeration should distribute cool air to all parts of the storage. The evaporative cooler may be floor-mounted or located near the ceiling in a fan room. Air should be discharged horizontally at ceiling level. Because the prevailing wet-bulb temperature limits the degree of cooling, a cooler with maximum reasonable size should be installed to reduce the storage temperature rapidly and as close to the wet-bulb temperature as possible. Generally, a cooler designed to exchange air every 3 min (20 air changes per hour) is the largest that can be installed. This capacity provides a complete air change every 1 to 1.5 min (40 to 60 air changes per hour) when the storage is loaded.

For further information on apple storage, see Chapter 35 of the 2014 *ASHRAE Handbook—Refrigeration*.

Citrus. The chief purpose of evaporative-cooling fruits and vegetables is to provide an effective, inexpensive means of improving storage. However, it also serves a special function in the case of oranges, grapefruit, and lemons. Although mature and ready for harvest, citrus fruits are often still green. Color change (degreening) is achieved through a sweating process in rooms equipped with direct evaporative cooling. Air with a high relative humidity and a moderate temperature is circulated continuously during the operation. Ethylene gas, the concentration depending on the variety and intensity of green pigment in the rind, is discharged into the rooms. Ethylene destroys chlorophyll in the rind, allowing the yellow or orange color to become evident. During degreening, a temperature of 21°C and a relative humidity of 88 to 90% are maintained in the sweat room. (In the Gulf States, 28 to 30°C with 90 to 92% rh is used.) The evaporative cooler is designed to deliver 1.1 L/s per kilogram of fruit.

Direct and indirect evaporative cooling is also used as a supplement to refrigeration in the storage of citrus fruit. Citrus storage requires refrigeration in the summer, but the required conditions can often be obtained using evaporative cooling during the fall, winter, and spring when the outdoor wet-bulb temperature is low. For further information, see Chapter 36 of the 2014 *ASHRAE Handbook—Refrigeration*.

Cooling Greenhouses

Proper regulation of greenhouse temperatures during the summer is essential for developing high-quality crops. The principal load on a greenhouse is solar radiation, which at sea level at about noon in the temperate zone is approximately 630 W/m². Smoke, dust, or heavy clouds reduce the radiation load. Table 5 gives solar

Table 4 Air Speed for Potato Storage Evaporative Cooler

Opening	Minimum Speed, Maximum Speed, Desired Speed,		
	m/s	m/s	m/s
Fresh air inlet	5	7	6
Return air opening	5	7	6
Exhaust opening	5	6	5.5
Main duct	2.5	4.5	3.5
Lateral duct	3.8	5.5	4.5
Slot	4.5	6.5	5.3

Table 5 Three-Year Average Solar Radiation for Horizontal Surface During Peak Summer Month

City	W/m ²	City	W/m ²
Albuquerque, NM	625	Lemont, IL	448
Apalachicola, FL	536	Lexington, KY	536
Astoria, OR	416	Lincoln, NE	473
Atlanta, GA	498	Little Rock, AR	467
Bismarck, ND	442	Los Angeles, CA	511
Blue Hill, MA	404	Madison, WI	435
Boise, ID	489	Medford, OR	536
Boston, MA	394	Miami, FL	483
Brownsville, TX	552	Midland, TX	558
Caribou, ME	363	Nashville, TN	486
Charleston, SC	480	Newport, RI	435
Cleveland, OH	480	New York, NY	442
Columbia, MO	483	Oak Ridge, TN	467
Columbus, OH	401	Oklahoma City, OK	521
Davis, CA	581	Phoenix, AZ	631
Dodge City, KS	581	Portland, ME	420
East Lansing, MI	416	Prosser, WA	555
East Wareham, MA	416	Rapid City, SD	480
El Paso, TX	615	Richland, WA	432
Ely, NV	552	Riverside, CA	555
Fort Worth, TX	555	St. Cloud, MN	416
Fresno, CA	593	San Antonio, TX	555
Gainesville, FL	492	Santa Maria, CA	593
Glasgow, MT	480	Sault Ste. Marie, MI	435
Grandby, CO	470	Sayville, NY	467
Grand Junction, CO	546	Schenectady, NY	369
Great Falls, MT	473	Seabrook, NJ	426
Greensboro, NC	489	Seattle, WA	369
Griffin, GA	517	Spokane, WA	439
Hatteras, NC	558	State College, PA	445
Indianapolis, IN	442	Stillwater, OK	527
Inyokern, CA	688	Tallahassee, FL	423
Ithaca, NY	457	Tampa, FL	527
Lake Charles, LA	505	Upton, NY	467
Lander, WY	558	Washington, D.C.	448
Las Vegas, NV	615		

radiation loads for representative cities in the United States. Note that the values cited are average solar heat gains, not peak loads. Temporary rises in temperature inside a greenhouse can be tolerated; an occasional rise above design conditions is not likely to cause damage.

Not all solar radiation that reaches the inside of the greenhouse becomes a cooling load. About 2% of the total solar radiation is used in photosynthesis. Transpiration of moisture varies by crop, but typically uses about 48% of the solar radiation. This leaves 50% to be removed by the cooler. Example 2 shows a method for calculating the size of a greenhouse evaporative cooling system.

Example 2. A direct evaporative cooler is to be installed in a 15 by 30 m greenhouse. Design conditions are 34°C db and 23°C wb, and average solar radiation is 435 W/m². An indoor temperature of 32°C db must not be exceeded at design conditions.

Solution: The direct evaporative air cooler is assumed to have a saturation effectiveness of 80%. Equation (2) may be used to determine the dry-bulb temperature of the air leaving the direct evaporative cooler:

$$t_2 = 34 - \frac{80}{100}(34 - 23) = 25.2^\circ\text{C}$$

The following equation, a modification of Equation (1), may be used to calculate the airflow rate that must be supplied by the direct evaporative cooler:

$$Q_{ra} = \frac{0.5AI_t}{\rho c_p(t_1 - t_2)} \quad (4)$$

where

A = greenhouse floor area, m²

I_t = total incident solar radiation, W/m² of receiving surface

ρc_p = density times specific heat of air ≈ 1150 J/(m³·K) at design conditions

For this problem

$$Q_{ra} = \frac{0.5 \times 15 \times 30 \times 435}{1150(32 - 25.2)} = 12.5 \text{ m}^3/\text{s}$$

Horizontal illumination from the direct rays of noonday summer sun with clear sky can be as much as 100 klx; under clear glass, this is approximately 90 klx. Crops such as chrysanthemums and carnations grow best in full sun, but many foliage plants, such as gloxinias and orchids, do not need more than 16 to 22 klx. Solar radiation is nearly proportional to light intensity. Thus, the greater the amount of shade, the smaller the cooling capacity required. A value of 1 klx is approximately equivalent to 9 W/m². Although atmospheric conditions such as clouds and haze affect the relationship, this is a safe conversion factor. This relationship should be used instead of Table 5 when illumination can be determined by design or measurement.

Direct evaporative cooling for greenhouses may be under either positive or negative pressure. Regardless of the type of system used, the length of air travel should not exceed 50 m. The temperature rise of the cool air limits the throw to this value. Air movement must be kept low because of possible mechanical damage to the plants, but it should generally not be less than 0.5 m/s in areas occupied by workers.

9. CONTROL STRATEGY TO OPTIMIZE ENERGY RECOVERY

Figures 18A and 18B show a heat pipe air-to-air heat exchanger used in a hospital for winter heat recovery and summer indirect (dry) evaporative cooling. The heat pipe has a double-walled partition between the clean outdoor air (OA) flow and the contaminated building exhaust air (EA). With this partition, leakage from the EA side of the heat exchanger to the supply air (SA) side is eliminated and fans may be positioned as shown for blow-through exhaust and draw-through supply. The heat pipe has a direct spray manifold on the building return air side of the heat exchanger for indirect evaporative cooling. The spray pump is located in a water sump below the wet side of the heat pipe and uses recirculated water from the sump to wet the heat pipe. Potable makeup water is supplied to replace the water evaporated in the indirect cooling process along with wasted water required to maintain dissolved solids in the sump at acceptable levels. Using the building return air wet-bulb condition of 15.5 to 18°C, the summer cooling effect is greatly increased over dry-to-dry heat recovery.

The operation of both outdoor (OA) and exhaust air (EA) face and bypass dampers, working in concert with supply and return fan variable-frequency drives (VFD), allow parasitic fan static pressure losses to be minimized during favorable climatic conditions. Figure 18B shows a total bypass of the heat exchanger in the range of ambient temperatures of 13 to 18°C. The value of energy recovered is exceeded by the fan energy penalty during these outdoor air temperatures.

10. AIR CLEANING AND SOUND ATTENUATION

Evaporative coolers are effective for improving IAQ in many ways. Their similarity to wet scrubbers means they can remove particulates and soluble gases. Direct evaporative coolers of all types perform some air cleaning. Rigid-media direct evaporative coolers are effective at removing particles down to about 1 μm. Air washers are effective down to about 10 μm.

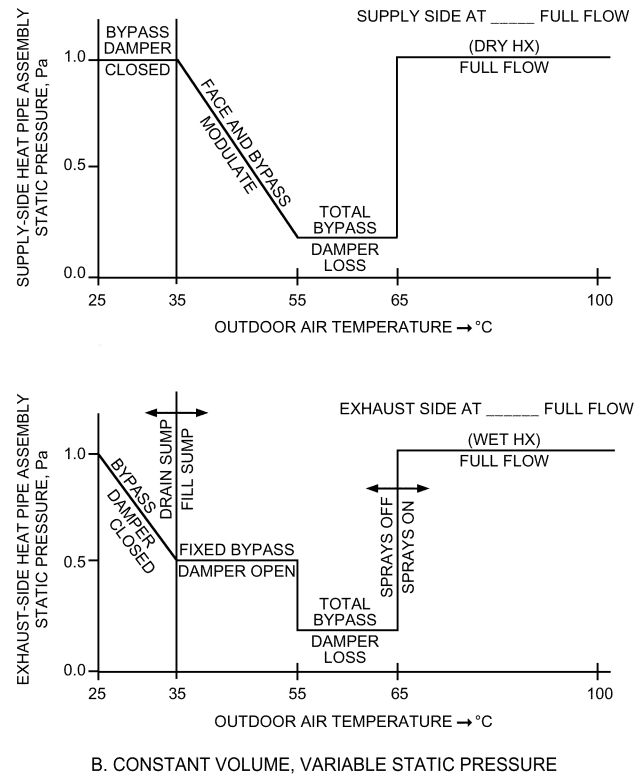
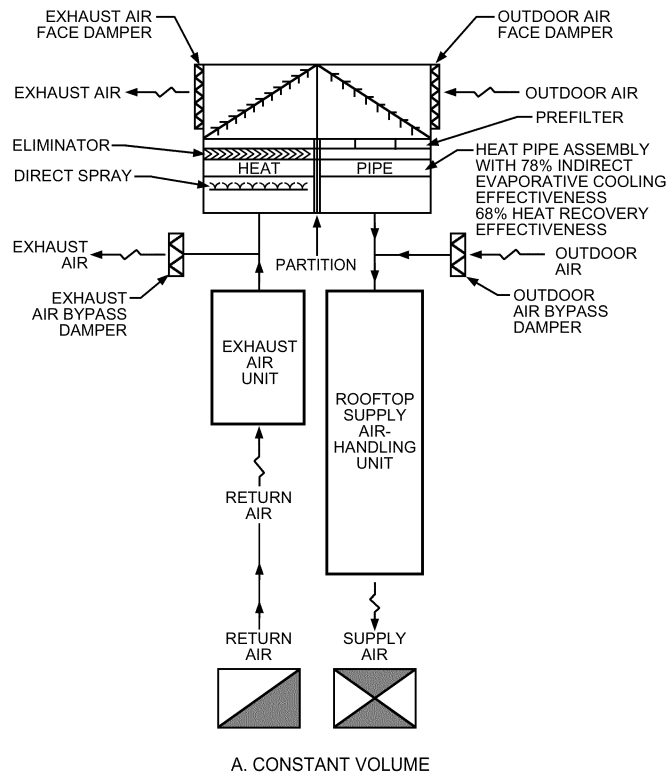

Fig. 18 Schematics for 100% Outdoor Air Used in Hospital

The dust removal efficiency of direct evaporative coolers depends largely on the size, density, wettability, and solubility of the dust particles. Larger, more wettable particles are the easiest to remove. Separation is largely a result of the impingement of particles on the wetted surface of the eliminator plates or on the surface of the media. Because the force of impact increases with the size of the solid, the impact (together with the adhesive quality of the wetted surface) determines the cooler's usefulness as a dust remover.

The standard low-pressure spray is relatively ineffective in removing most atmospheric dusts. Direct evaporative coolers are of little use in removing soot particles because their greasy surface will not adhere to the wet plates or media. Direct evaporative coolers are also ineffective in removing smoke, because the small particles (less than 1 μm) do not impinge with sufficient impact to pierce the water film and be held on the media. Instead, the particles follow the air path between the media surfaces.

In the case of cross-corrugated media, the particles are removed from the media by the recirculated water. In locations with high particulate contamination, the sump and water distribution system should be flushed at least quarterly. If the particulate contains organic matter, it can contribute to biological growth on the media.

Control of Gaseous Contaminants

When used in a makeup air system comprised of a mixture of outdoor air and recirculated air, direct evaporative coolers function as scrubbers and reduce some gaseous contaminants found in outdoor air. These contaminants may concentrate in the recirculating water, so some water must be bled off. For more information regarding control of gaseous contaminants, see Chapter 46.

Evaporative coolers near sources of airborne nitric acid, chlorine, or ammonia absorb these chemicals, which can damage the cooler. The amount of soluble gases cleaned from the air depends on the air/water mixing, retention time, the water's pH, and the bleed rate.

Table 6 Particulate Removal Efficiency of Rigid Media at 2.54 m/s Air Velocity

Media Depth, mm	Particle Sizes, μm					
	0.3 to 0.5	0.5 to 0.7	0.7 to 1	1 to 5	5 to 10	>10
6 150	1.7%	21.3%	25.6%	43.6%	46.2%	61.3%
12 300	9.6%	31.8%	55.4%	87.2%	96.5%	97.3%

Source: Data courtesy of Munters Corporation.

Table 7 Insertion Loss for 300 mm Depth of Rigid Media at 2.8 m/s Air Velocity, dB

Media Orientation	Octave Band Center Frequency, Hz							
	63	125	250	500	1000	2000	4000	8000
Dry, forward flow	2	1	2	5	4	5	10	14
Reverse flow	4	1	2	4	5	4	9	13
Wet, forward flow	1	0	3	3	3	4	6	9
Reverse flow	3	1	3	3	3	3	4	8

Source: Data courtesy of Munters Corporation.

When exposed to soluble gases, evaporative coolers should be operated with a high bleed rate.

Ozone levels of the airstream can be reduced using evaporative coolers and air washers. Ozone is fairly unstable in a watery solution, decaying to ordinary diatomic oxygen. The stability of ozone absorbed in water depends on water temperature, ozone concentration, and length of holding time. Higher room humidity can vastly improve the rate at which it decays back to oxygen (Sterling et al. 1985).

Legionnaires' Disease. There have been no known cases of Legionnaires' disease with air washers or wetted-media evaporative air coolers. This is can be attributed to the low temperature of the recirculated water, which is not conducive to *Legionella* bacteria

growth, as well as the absence of aerosolized water carryover that could transmit the bacteria to a host (ASHRAE *Guideline* 12-2000).

Evaporative cooler media has some sound attenuation properties. This insertion loss varies, depending on whether the media is wet or dry and whether the sound is travelling counter to (reverse flow) or with (forward flow) the airstream. Sound attenuation for 300 mm depth of rigid media can be found in [Table 7](#). Components in the path of airflow in an air-handler plenum or duct provide some sound attenuation; one of the more effective at reducing sound pressure levels is the rigid-media direct evaporative cooler (DEC). Periannan (2013) performed tests in accordance with ASTM *Standard* E477-90 to measure insertion losses (1) with airflow in the direction of sound and (2) with reverse airflow. Measurements were also made at different velocities and for different media depths. As [Table 7](#) shows, a rigid-media DEC is quite effective in reducing low-frequency noise levels, which are usually the most difficult to reduce. Rigid media should likely not be used purely as a sound attenuator, but noise reduction can be an additional benefit when these types are selected.

11. ECONOMIC FACTORS

Design of direct and indirect evaporative cooling systems and sizing of equipment is based on the load requirements of the application and on the local dry- and wet-bulb design conditions, which may be found in Chapter 14 of the 2013 *ASHRAE Handbook—Fundamentals* (with extended data and locations on the CD accompanying that volume). Total energy use for a specific application during a set period may be forecasted by using annual weather data. Dry-bulb and mean coincident wet-bulb temperatures, with the hours of occurrence, can be summarized and used in a modified bin procedure. The calculations must reflect the hours of use, conditions of load, and occupancy. Because of annual variations in dry- and wet-bulb temperatures and the effect of increasing cooling capacity with decreasing wet-bulb temperatures, bin calculations using mean coincident wet-bulb temperatures generally produce conservative results. When comparing various cooling systems, cost analysis should include annual energy reduction at the applicable electrical rate, plus anticipated energy cost escalation over the expected life.

Many areas have time-of-day electrical metering as an incentive to use energy during off-peak hours when rates are lowest. Reducing air-conditioning kilowatt demand is especially important in areas with ratcheted demand rates (Scofield and DesChamps 1980). Thermal storage using ice banks or chilled-water storage may be used as part of a multistage evaporatively refrigerated cooler to combine the energy-saving advantages of evaporative cooling and off-peak savings of thermal storage (Eskra 1980).

Direct Evaporation Energy Saving

Direct evaporative cooling may be used in all climates to save cooling and humidification energy. In humid climates, the benefits of direct evaporation are realized during periods when outdoor air is warm and dry, but cooling savings are unlikely to be realized during peak design conditions. In more arid areas, direct evaporative cooling may partially or fully offset mechanical cooling at peak load conditions. Humidification energy savings may be realized during the heating season when outdoor air is used to provide cooling and humidification. If properly controlled, direct evaporative cooling can use waste heat otherwise rejected from buildings when outdoor air is used for cooling.

Indirect Evaporation Energy Saving

Indirect evaporative cooling may be used in all climates to save cooling and, in some applications, heating energy. In humid climates, indirect evaporative cooling may be used throughout the cooling cycle to precool outdoor air. Indirect evaporative cooling can be used to extend the range of 100% outdoor air ventilation to

both higher and lower temperatures, and to increase the percentage of outdoor air a system can support at any given temperature through heat recovery. In high-humidity areas, indirect evaporative cooling may be used to (1) partially offset mechanical cooling requirements at peak load conditions and (2) provide better control over low-load humidity conditions by permitting the use of smaller refrigeration equipment to provide ventilation over a wider range of outdoor air conditions. The cost of heating may be reduced when operating below temperatures at which minimum outdoor air quantities exceed the rates of ventilation required for free cooling by using heat recovered from building exhausts.

Water Cost for Evaporative Cooling

Typically, domestic service water is used for evaporative cooling to avoid excessive scaling and associated problems with poor water quality. In designing evaporative coolers, the cost of water treatment is included in the overall project cost. However, water cost is typically ignored for evaporative coolers because it is usually an insignificant part of the operational cost. Depending on the ambient dry-bulb temperature and wet-bulb depression for a specific location, the cost of water could become a significant part of the operational cost, because the greater the differential between dry- and wet-bulb temperatures, the greater the amount of water evaporated (Mathur 1997, 1998).

12. PSYCHROMETRICS

[Figure 19](#) shows the two-stage (indirect/direct) process applied to nine cities in the western United States. The examples indicated are primarily shown for arid areas, but the principles also apply to moderately humid and humid areas when weather conditions permit. For each city indicated, the entering conditions to the first-stage indirect unit are at or near the 0.4% design dry- and wet-bulb temperatures in Chapter 14 of the 2013 *ASHRAE Handbook—Fundamentals*. Although higher effectiveness can be achieved for both the indirect and direct evaporative processes modeled, the effectiveness ratings are 60% for the first (indirect) stage and 90% for the second (direct) stage. Leaving air temperatures range from 11 to 21°C, with leaving conditions approaching saturation.

[Figure 20](#) projects space conditions in each city at 25.5°C db for these second-stage supply temperatures based on a 95% room sensible heat factor (i.e., room sensible heat/room total heat). Except in Wichita, Los Angeles, and Seattle, room conditions can be maintained in the comfort zone without a refrigerated third stage. But even in these cities, third-stage refrigeration requirements are

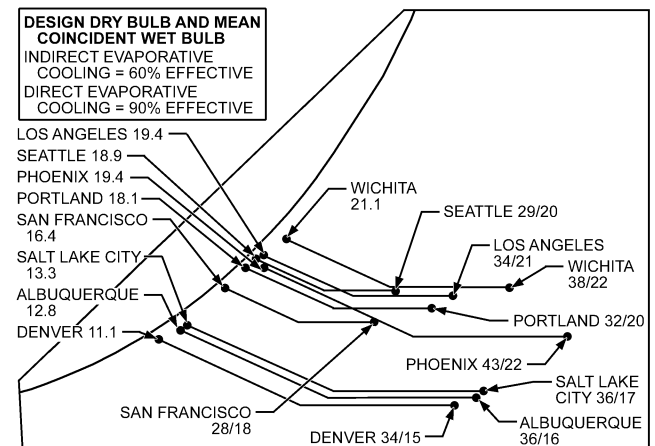

Fig. 19 Two-Stage Evaporative Cooling at 0.4% Design Condition in Various Cities in Western United States

sharply reduced as compared to conventional mechanical cooling. However, Figures 19 and 20 indicate the need to consider the following factors when deciding whether to include a third cooling stage:

- As the room sensible heat factor decreases, the supply air temperature required to maintain a given room condition decreases.
- As supply air temperature increases, the supply air quantity must increase to maintain space temperature, which results in higher air-side initial cost and increased supply air fan power.
- A decrease in the required room dry-bulb temperature requires an increase in the supply air quantity. For a given room sensible heat factor, a decrease in room dry-bulb temperature may cause the relative humidity to exceed the comfort zone.
- The suggested 0.4% entering design (dry-bulb/mean wet-bulb) conditions are only one concern. Partial-load conditions must also be considered, along with the effect (extent and duration) of spike wet-bulb temperatures. Mean wet-bulb temperatures can be used to determine energy use of the indirect/direct system. However, the higher wet-bulb temperature spikes should be considered to determine their effect on room temperatures.

An ideal condition for maximum use with minimum energy consumption of a two- and three-stage indirect/direct system is a room sensible heat factor of 90% and higher, a supply air temperature of 16°C, and a dry-bulb room design temperature of 25.5°C. In many cases, third-stage refrigeration is required to ensure satisfactory dry-bulb temperature and relative humidity. Example 3 shows a method for determining the refrigeration capacity for three-stage cooling. Figure 21 is a psychrometric diagram of the process.

Example 3. Assume the following:

- Supply air quantity = 11.3 m³/s; supply air temperature = 16°C
- Design condition = 37°C db and 20°C wb
- Effectiveness of indirect unit = 60%;
- Effectiveness of direct unit = 90%

Using Equation (2), the leaving air state from the indirect unit (first stage) is

$$37 - 0.60(37 - 20) = 26.8^\circ\text{C db (16.6}^\circ\text{C wb)}$$

Using Equation (2), the leaving air state from the direct unit (second stage) is

$$26.8 - 0.90(26.8 - 16.6) = 17.6^\circ\text{C db (16.6}^\circ\text{C wb)}$$

Calculate booster refrigeration capacity to drop the supply air temperature from 17.6°C to the required 16°C.

If the refrigerating coil is located ahead of the direct unit,

$$\text{kW cooling} = \frac{(h_1 - h_2)(\text{supply air, L/s})}{\text{Specific volume dry air at leaving air condition}}$$

With numeric values of enthalpies h_1 and h_2 (in kJ/kg) and the specific volume of air (in m³/kg_{da}) taken from ASHRAE Psychrometric Chart No. 1, the cooling load is calculated as follows:

$$(46.5 - 42.8)11.3/0.860 = 48.6 \text{ kW}$$

The load for a coil located in the leaving air of the direct unit is

$$(46.6 - 42.9)11.3/0.838 = 49.9 \text{ kW}$$

Depending on the location of the booster coil, the preceding calculations can be used to determine third-stage refrigeration capacity and to select a cooling coil.

Using this example, refrigeration sizing can be compared to conventional refrigeration without staged evaporative cooling. Assuming mixed air conditions to the coil of 27°C db and 19.1°C wb, and the same 16°C db supply air as shown in Figure 20, the refrigerated capacity is

$$(54.1 - 42.9)11.3/0.833 = 152 \text{ kW}$$

This represents an increase of 103 kW. The staged evaporative effect reduces the required refrigeration by 68%.

13. ENTERING AIR CONSIDERATIONS

The effectiveness of direct and indirect evaporative cooling depends on the entering air condition. Where outdoor air is used in a direct evaporative cooler, the design is affected by the prevailing outdoor dry- and wet-bulb temperatures as well as by the application. Where conditioned exhaust air is used as secondary air for indirect evaporative cooling, the design is less affected by local weather conditions, which makes evaporative cooling viable in hot and humid environments.

For example, in arid areas like Reno, Nevada, a simple, direct evaporative cooler with an effectiveness of 80% provides a leaving air temperature of 19.8°C when dry- and wet-bulb temperatures of the entering air are 35 and 16°C, respectively. In the same location, adding an indirect evaporative precooling stage with an effectiveness of 80% produces a leaving air condition of 12°C.

In a location such as Atlanta, Georgia, with design temperatures of 34 and 23.5°C, the same direct evaporative cooler could supply only 25.6°C. This could be reduced to 22.1°C by adding an 80% effective indirect evaporative precooling stage (Supple 1982). If exhaust air from the building served is provided at a stable 24°C db and 17°C wb, an indirect evaporative precooler could deliver air at 20.5°C, substantially reducing outdoor air cooling loads. Under these conditions, indirect evaporative precoolers can provide limited dehumidification capabilities.

Long-term benefits to owners of direct evaporative cooling systems include a 20 to 40% reduction of utility costs compared to mechanical refrigeration (Watt 1988). When used to control humidity, the reduction in cooling and humidification energy use ranges from 35 to 90% (Lentz 1991). Although direct evaporative cooling does not reduce peak cooling loads in other than arid areas, it can reduce both total cooling energy and humidification energy requirements in a wide range of environments, including hot and humid ones.

Indirect evaporative cooling lowers the temperature (both dry- and wet-bulb) of the air entering a direct evaporative cooling stage and, consequently, lowers the supply air temperature. When used with mechanical cooling on 100% outdoor air systems, with the secondary air taken from the conditioned space, the precooling effect may reduce peak cooling loads between 50 and 70%. Total cooling requirements may be reduced between 40 and 85% annually depending on location, system configuration, and load characteristics. Indirect evaporative coolers may also function as heat recovery systems, which expands the range of conditions over which the process is used. Indirect evaporative cooling, when used with building exhaust air, is especially effective in hot and humid climates.

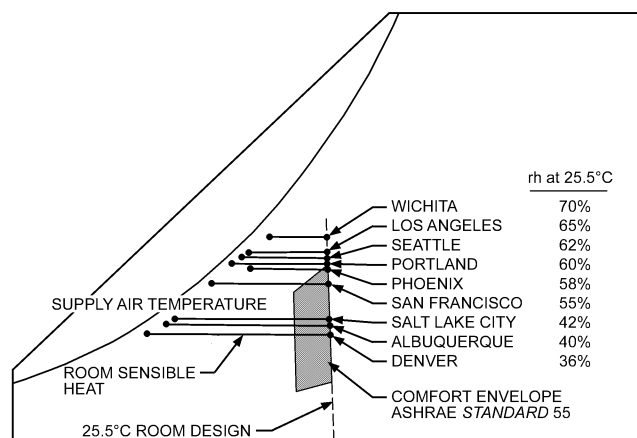

Fig. 20 Final Room Design Conditions After Two-Stage Evaporative Cooling

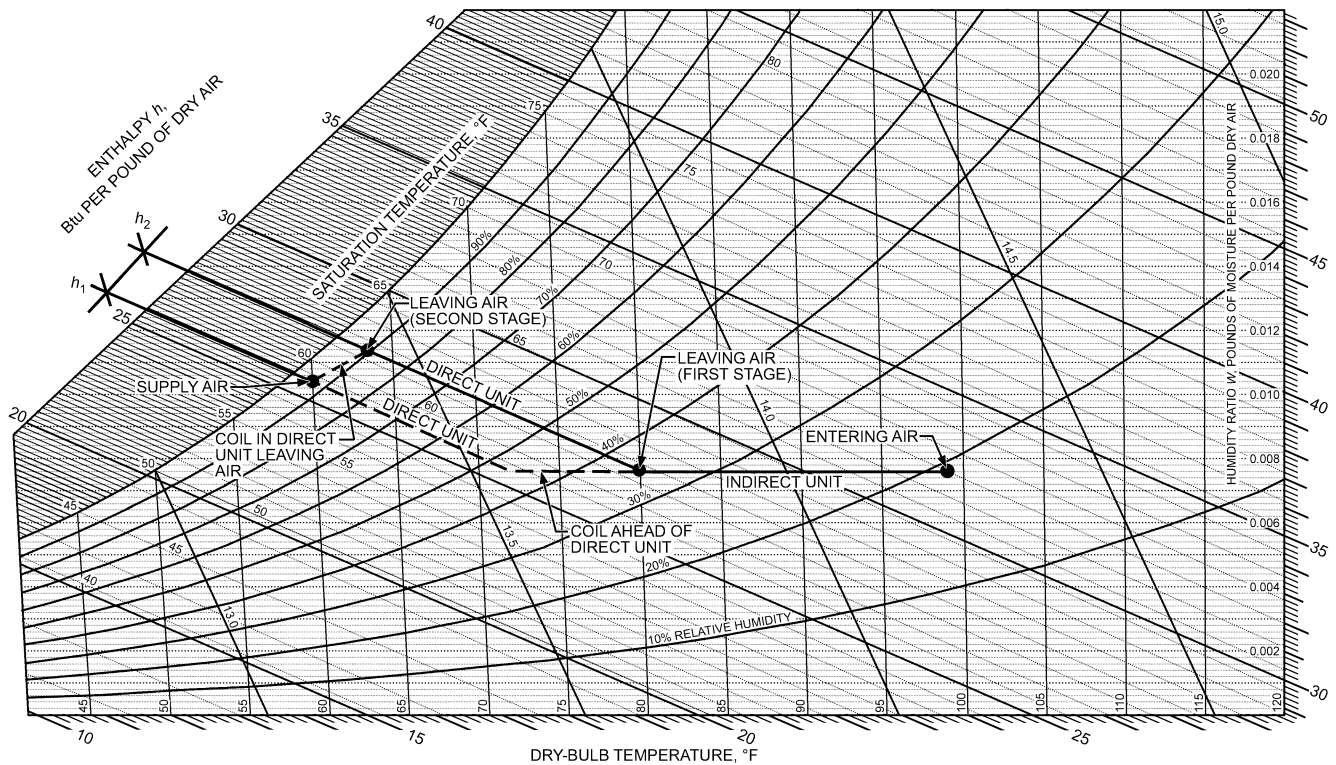

Fig. 21 Psychrometric Diagram of Three-Stage Evaporative Cooling Example 3

REFERENCES

- ASHRAE. 2000. Minimizing the risk of Legionellosis associated with building water systems. *Guideline 12-2000*.
- ASHRAE. 2013. Ventilation for acceptable indoor air quality. ANSI/ASHRAE Standard 62.1-2013.
- Colvin, T.D. 1995. Office tower reduces operating costs with two-stage evaporative cooling system. *ASHRAE Journal* 37(3):23-24.
- Crow, L.W. 1972. Weather data related to evaporative cooling. Research Report 2223. *ASHRAE Transactions* 78(1):153-164.
- Des Champs, N.H., and K. Dunnivant. 2014. Free cooling technologies. Ch. 25 in *Data center handbook*, H. Geng, ed. John Wiley & Sons, New York.
- Ecodyne Corp. 1980. *Weather data handbook*. McGraw-Hill, New York.
- Eskra, N. 1980. Indirect/direct evaporative cooling systems. *ASHRAE Journal* 22(5):22.
- Felver, T.G., M. Scofield, and K. Dunnivant. 2001. Cooling California's computer centers. *HPAC Magazine*, pp. 60-61.
- Lentz, M.S. 1991. Adiabatic saturation and VAV: A prescription for economy and close environmental control. *ASHRAE Transactions* 97(1):477-485. Paper NY-91-04-3.
- Mathur, G.D. 1990. Indirect evaporative cooling using two-phase thermosiphon loop heat exchangers. *ASHRAE Transactions* 96(1):1241-1249. Paper AT-90-18-3.
- Mathur, G.D. 1997. Performance enhancement of existing air conditioning systems. *Intersociety Energy Conversion Engineering Conference, American Institute of Chemical Engineers* 3:1618-1623.
- Mathur, G.D. 1998. Predicting yearly energy savings using bin weather data with heat pipe exchangers with indirect evaporative cooling. *Intersociety Energy Conversion Engineering Conference, Paper 98-IECEC-049*.
- Mathur, G.D., and D.Y. Goswami. 1995. Indirect evaporative cooling retrofit as a demand side management strategy for residential air conditioning. *Intersociety Energy Conversion Engineering Conference, ASME* 2:317-322.
- Mathur, G.D., D.Y. Goswami, and S.M. Kulkarni. 1993. Experimental investigation of a residential air conditioning system with an evaporatively cooled condenser. *Journal of Solar Energy Engineering* 115:206-211.
- Periannan, V. 2013. Humidification, filtration and sound attenuation benefits of rigid media direct evaporative cooling systems while providing energy savings. Presented at ASHRAE Annual Conference, Denver, CO. Paper DE-13-C049.
- Scofield, C.M. 1986. The heat pipe used for dry evaporative cooling. *ASHRAE Transactions* 92(1B):371-381. Paper SF-86-08-3.
- Scofield, C.M. 1994. California classroom VAV with IAQ and energy savings, too. *HPAC Magazine*, p. 89.
- Scofield, M., and J. Bergman. 1997. ASHRAE Standard 62R: A simple method of compliance. *HPAC Magazine* (October):67.
- Scofield, M., and N. Des Champs. 1980. EBTR compliance and comfort too. *ASHRAE Journal* 22(6):61.
- Scofield, C.M., and N.H. Des Champs. 1984. Indirect evaporative cooling using plate-type heat exchangers. *ASHRAE Transactions* 90(1B):148-153. Paper AT-84-03-2.
- Scofield, M., and J. Taylor. 1986. A heat pipe economy cycle. *ASHRAE Journal* 28(10):35-40.
- Sterling, E.M., A. Arundel, and T.D. Sterling. 1985. Criteria for human exposure to humidity in occupied buildings. *ASHRAE Transactions* 91(1B):611-622. Paper CH-85-13-1.
- Stewart, W.E., Jr. 1999. *Design guide for combustion turbine inlet air cooling systems*. ASHRAE.
- Supple, R.G. 1982. Evaporative cooling for comfort. *ASHRAE Journal* 24(8):42.
- Watt, J.R. 1988. Power cost comparisons: Evaporative vs. refrigerative cooling. *ASHRAE Transactions* 94(2):1108-1115. Paper OT-88-04-3.
- Wu, H., and J.L. Yellot. 1987. Investigation of a plate-type indirect evaporative cooling system for residences in hot and arid climates. *ASHRAE Transactions* 93(1):1252-1260. Paper NY-87-12-2.

BIBLIOGRAPHY

- ASHRAE. 2004. Thermal environmental conditions for human occupancy. ANSI/ASHRAE Standard 55-2004.
- Peterson, J.L., and B.D. Hunn. 1992. Experimental performance of an indirect evaporative cooler. *ASHRAE Transactions* 98(2):15-23. Paper 3598.

52.20

2015 ASHRAE Handbook—HVAC Applications (SI)

Stewart, W.E., Jr., and L.A. Stickler. 1999. Designing for combustion turbine inlet air cooling. *ASHRAE Transactions* 105(1). Paper 4242.

Strock, C., ed. 1959. *Handbook of air conditioning, heating & ventilation*. Industrial Press, New York.

Watt, J.R. 1997. *Evaporative air conditioning handbook*, 3rd ed. Chapman & Hall, New York.

Yellott, J.I., and J. Gamero. 1984. Indirect evaporative air coolers for hot, dry climates. *ASHRAE Transactions* 90(1B):139-147. Paper AT-84-03-1.