



5751
FEDERATION EUROPEENNE DE LA MANUTENTION
SECTION I
HEAVY LIFTING APPLIANCES

F. E. M.
1.001
3RD EDITION
1987.10.01

RULES FOR THE DESIGN OF HOISTING APPLIANCES

BOOKLET 2

CLASSIFICATION AND LOADING ON STRUCTURES AND MECHANISMS



The total 3rd Edition comprises booklets 1 to 8

Copyright by FEM Section I

Also available in French and German

This booklet is part of the "Rules for the design of hoisting appliances" consisting of 8 booklets :

Booklet 1 - Object and scope

Booklet 2 - Classification and loading on structures and mechanisms

Booklet 3 - Calculating the stresses in structures

Booklet 4 - Checking for fatigue and choice of mechanism components

Booklet 5 - Electrical equipment

Booklet 6 - Stability and safety against movement by the wind

Booklet 7 - Safety rules

Booklet 8 - Test loads and tolerances

and must not be used separately.

BOOKLET 2

CLASSIFICATION AND LOADING ON STRUCTURES AND MECHANISMS

CONTENTS

	<u>Clause</u>	<u>Page</u>
GROUP CLASSIFICATION OF HOISTING APPLIANCES AND THEIR COMPONENT PARTS	2.1	2- 3
- General plan of classification	2.1.1.	2- 3
- Classification of hoisting appliances as a whole	2.1.2.	2- 3
. Classification system	2.1.2.1.	2- 3
. Classes of utilization	2.1.2.2.	2- 3
. Load spectrum	2.1.2.3.	2- 4
. Group classification of hoisting appliances	2.1.2.4.	2- 6
. Guidance on group classification of an appliance	2.1.2.5.	2- 6
- Classification of individual mechanisms as a whole	2.1.3.	2- 6
. Classification system	2.1.3.1.	2- 6
. Class of utilization	2.1.3.2.	2- 8
. Loading spectrum	2.1.3.3.	2- 8
. Group classification of individual mechanisms as a whole	2.1.3.4.	2- 9
. Guidance for group classification of individual mechanisms as a whole	2.1.3.5.	2- 9
- Classification of components	2.1.4.	2-11
. Classification system	2.1.4.1.	2-11
. Classes of utilization	2.1.4.2.	2-11
. Stress spectrum	2.1.4.3.	2-12
. Group classification of components	2.1.4.4.	2-14
LOADS ENTERING INTO THE DESIGN OF STRUCTURES	2.2	2-15
- Principal loads	2.2.1.	2-15
- Loads due to vertical motions	2.2.2.	2-15
. Loads due to hoisting of the working load	2.2.2.1.	2-16
.. Values of the dynamic coefficient Ψ	2.2.2.1.1.	2-16
. Loads due to acceleration (or deceleration) of the hoisting motion and to vertical shock loadings when travelling along rail tracks	2.2.2.2.	2-17
. Special case	2.2.2.3.	2-17
- Loads due to horizontal motions S_H	2.2.3.	2-19
. Horizontal effects due to accelerations (or decelerations)	2.2.3.1.	2-19
.. Traverse and travel motions	2.2.3.1.1.	2-19
.. Slewing and luffing (derricking) motions	2.2.3.1.2.	2-20
. Effects of centrifugal force	2.2.3.2.	2-20
. Transverse reactions due to rolling action	2.2.3.3.	2-20
. Buffer effects S_T	2.2.3.4.	2-21
.. Buffer effects on the structure	2.2.3.4.1.	2-21
.. Buffer effects on the suspended load	2.2.3.4.2.	2-22

	<u>Clause</u>	<u>Page</u>
- Loads due to climatic effects	2.2.4.	2-22
. Wind action	2.2.4.1.	2-22
.. Wind pressure	2.2.4.1.1.	2-22
.. Design wind conditions	2.2.4.1.2.	2-22
.. Wind load calculations	2.2.4.1.3.	2-24
.. Force coefficients	2.2.4.1.4.	2-25
. Snow load	2.2.4.2.	2-30
. Temperature variations	2.2.4.3.	2-30
- Miscellaneous loads	2.2.5.	2-30
. Loads carried by platforms	2.2.5.1.	2-30
CASES OF LOADING	2.3.	2-30
- Case I : Appliance working without wind	2.3.1.	2-31
- Case II : Appliance working with wind	2.3.2.	2-31
- Case III : Appliance subject to exceptional loads	2.3.3.	2-31
- Choosing the amplifying coefficient γ_c	2.3.4.	2-32
SEISMIC EFFECTS	2.4	2-32
LOADS ENTERING INTO THE DESIGN OF MECHANISMS	2.5.	2-33
- Type S_M loads	2.5.1.	2-33
- Type S_R loads	2.5.2.	2-33
CASES OF LOADING	2.6.	2-34
- Case I : Normal service without wind	2.6.1.	2-34
. Type S_M loads	2.6.1.1.	2-34
. Type S_R loads	2.6.1.2.	2-34
Case II : Normal service with wind	2.6.2.	2-35
. Type S_M loads	2.6.2.1.	2-35
. Type S_R loads	2.6.2.2.	2-35
- Case III : Exceptional loads	2.6.3.	2-35
. Type S_M loads	2.6.3.1.	2-35
. Type S_R loads	2.6.3.2.	2-36
- Application for calculating S_M	2.6.4.	2-36
. Hoisting motions	2.6.4.1.	2-36
. Horizontal motions	2.6.4.2.	2-37
. Combined motions	2.6.4.3.	2-37

APPENDIX

HARMONISATION OF THE CLASSIFICATIONS OF APPLIANCES AND MECHANISMS	A-2.1.1.	2-39
CALCULATION OF LOADS DUE TO ACCELERATION OF HORIZONTAL MOTIONS	A-2.2.3.	2-45
LIST OF SYMBOLS AND NOTATIONS	See booklet .	

2.1

GROUP CLASSIFICATION OF HOISTING APPLIANCES AND THEIR COMPONENT PARTS

2.1.1.

GENERAL PLAN OF CLASSIFICATION

In the design of a hoisting appliance and its component parts, account must be taken of the duty which they will be required to perform during their duration of use ; for this purpose group classification is employed of :

- the appliance as a whole ;
- the individual mechanisms as a whole ;
- the structural and mechanical components.

This classification is based on two criteria, namely :

- the total duration of use of the item considered ;
- the hook load, loading or stress spectra to which the item is subjected.

2.1.2.

CLASSIFICATION OF HOISTING APPLIANCES AS A WHOLE

2.1.2.1.

CLASSIFICATION SYSTEM

Appliances as a whole are classified in eight groups, designated by the symbols A1, A2, ..., A8 respectively (see section 2.1.2.4.), on the basis of ten classes of utilization and four load spectra.

2.1.2.2.

CLASSES OF UTILIZATION

By duration of use of a hoisting appliance is meant the number of hoisting cycles which the appliance performs. A hoisting cycle is the entire sequence of operations commencing when a load is hoisted and ending at the moment when the appliance is ready to hoist the next load.

The total duration of use is a computed duration of use, considered as a guide value, commencing when the appliance is put into service and ending when it is finally taken out of service.

On the basis of the total duration of use, we have ten classes of utilization, designated by the symbols U0, U1, ..., U9. They are defined in table 2.1.2.2.

Table T.2.1.2.2. - Classes of utilization

Symbol	Total duration of use (number n_{max} of hoisting cycles)			
U0			$n_{max} \ll$	16 000
U1	16 000	<	$n_{max} \ll$	32 000
U2	32 000	<	$n_{max} \ll$	63 000
U3	63 000	<	$n_{max} \ll$	125 000
U4	125 000	<	$n_{max} \ll$	250 000
U5	250 000	<	$n_{max} \ll$	500 000
U6	500 000	<	$n_{max} \ll$	1 000 000
U7	1 000 000	<	$n_{max} \ll$	2 000 000
U8	2 000 000	<	$n_{max} \ll$	4 000 000
U9	4 000 000	<	n_{max}	

2.1.2.3. LOAD SPECTRUM

The load spectrum characterizes the total number of loads hoisted during the total duration of use (see 2.1.2.2.) of an appliance. It is a distribution function (summed) $y = f(x)$, expressing the fraction x ($0 \leq x \leq 1$) of the total duration of use, during which the ratio of the hoisted load to the safe working load attains at least a given value y ($0 \leq y \leq 1$).

Examples of a load spectrum are given in figs. 2.1.2.3.1. - a and b.

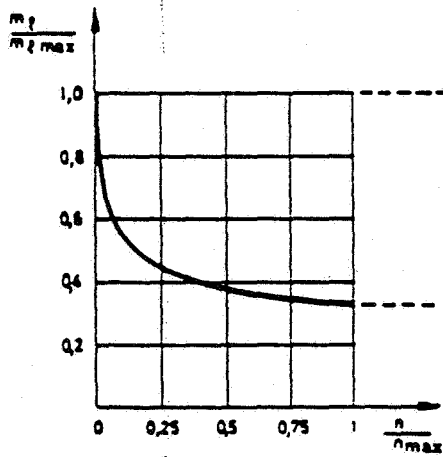

Figure 2.1.2.3.1. - a

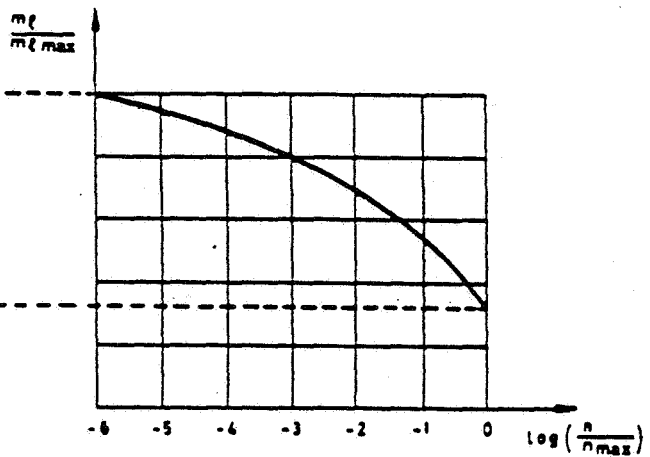

Figure 2.1.2.3.1. - b

m_l = loads ;

$m_{l_{max}}$ = safe working load ;

n = number of hoisting cycles in respect of which the hoisted load is greater than or equal to m_l ;

n_{max} = number of hoisting cycles determining the total duration of use.

Each spectrum is assigned a spectrum factor k_p , defined by :

$$k_p = \int_0^1 y^d dx$$

For the purposes of group classification the exponent d is taken by convention as equal to 3.

In many applications the function $f(x)$ may be approximated by a function consisting of a certain number r of steps (see fig. 2.1.2.3.2.), comprising respectively n_1, n_2, \dots, n_r hoisting cycles, the load may be considered as practically constant and equal to $m\ell_i$ during the n_i cycles of the i^{th} step. If n_{max} represents the total duration of use and $m\ell_{\text{max}}$ the greatest among the $m\ell_i$ loads, there exists a relation :

$$n_1 + n_2 + \dots + n_r = \sum_{i=1}^r n_i = n_{\text{max}}$$

or in approximated form :

$$k_p = \left(\frac{m\ell_1}{m\ell_{\text{max}}}\right)^3 \frac{n_1}{n_{\text{max}}} + \left(\frac{m\ell_2}{m\ell_{\text{max}}}\right)^3 \frac{n_2}{n_{\text{max}}} + \dots + \left(\frac{m\ell_r}{m\ell_{\text{max}}}\right)^3 \frac{n_r}{n_{\text{max}}}$$

$$k_p = \sum_{i=1}^r \left(\frac{m\ell_i}{m\ell_{\text{max}}}\right)^3 \frac{n_i}{n_{\text{max}}}$$

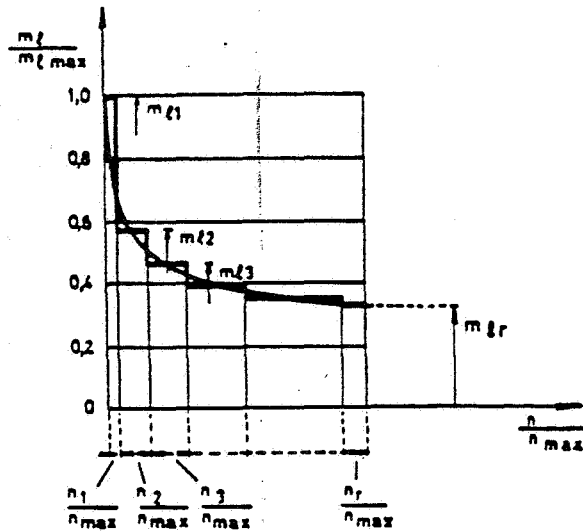

Figure 2.1.2.3.2.

According to its load spectrum, a hoisting appliance is placed in one of the four spectrum classes Q1, Q2, Q3, Q4 defined in table T.2.1.2.3.

Table T.2.1.2.3.

Spectrum classes

Symbol	Spectrum factor k_p			
Q1			$k_p \leq$	0.125
Q2	0.125	<	$k_p \leq$	0.250
Q3	0.250	<	$k_p \leq$	0.500
Q4	0.500	<	$k_p \leq$	1.000

2.1.2.4. GROUP CLASSIFICATION OF HOISTING APPLIANCES

Group classification of hoisting appliances as a whole is determined from table T.2.1.2.4.

Table T.2.1.2.4.

Appliance groups

Load spectrum class	Class of utilization									
	U0	U1	U2	U3	U4	U5	U6	U7	U8	U9
Q1	A1	A1	A1	A2	A3	A4	A5	A6	A7	A8
Q2	A1	A1	A2	A3	A4	A5	A6	A7	A8	A8
Q3	A1	A2	A3	A4	A5	A6	A7	A8	A8	A8
Q4	A2	A3	A4	A5	A6	A7	A8	A8	A8	A8

2.1.2.5. GUIDANCE ON GROUP CLASSIFICATION OF AN APPLIANCE

Directions concerning the classification of hoisting appliances are given in table T.2.1.2.5.

Since appliances of the same type may be used in a wide variety of ways, the grouping shown in this table can only be taken as a model. In particular, where several groups are shown as appropriate to an appliance of a given type, it is necessary to ascertain, on the basis of the appliance's computed total duration of use and load spectrum, in which classes of utilization and load spectrum it has to be placed, and consequently in which group.

2.1.3. CLASSIFICATION OF INDIVIDUAL MECHANISMS AS A WHOLE

2.1.3.1. CLASSIFICATION SYSTEM

Individual mechanisms as a whole are classified in eight groups, designated respectively by the symbols M1, M2, ..., M8 (see 2.1.3.4.), on the basis of ten classes of utilization and four classes of loading spectrum.

Table T.2.1.2.5. - Guidance for group classification of appliances

Reference	Type of appliance	Particulars concerning nature of use (1)	Appliance group (see 2.1.2.4.)
	Designation		
1	Hand-operated appliances		A1 - A2
2	Erection cranes		A1 - A2
3	Erection and dismantling cranes for power stations, machine shops, etc.		A2 - A4
4	Stocking and reclaiming transporters	Hook duty	A5
5	Stocking and reclaiming transporters	Grab or magnet	A6 - A8
6	Workshop cranes		A3 - A5
7	Overhead travelling cranes, pig-breaking cranes, scrapyards cranes	Grab or magnet	A6 - A8
8	Ladle cranes		A6 - A8
9	Soaking-pit cranes		A8
10	Stripper cranes, open-hearth furnace-charging cranes		A8
11	Forge cranes		A6 - A8
12.a	Bridge cranes for unloading, bridge cranes for containers	Hook or spreader duty	A5 - A6
12.b	Other bridge cranes (with crab and/or slewing jib crane)	Hook duty	A4
13	Bridge cranes for unloading, bridge cranes (with crab and/or slewing jib crane)	Grab or magnet	A6 - A8
14	Drydock cranes, shipyard jib cranes, jib cranes for dismantling	Hook duty	A3 - A5
15	Dockside cranes (slewing, on gantry), floating cranes and pontoon derricks	Hook duty	A5 - A6
16	Dockside cranes (slewing, on gantry), floating cranes and pontoon derricks	Grab or magnet	A6 - A8
17	Floating cranes and pontoon derricks for very heavy loads (usually greater than 100 t)		A2 - A3
18	Deck cranes	Hook duty	A3 - A4
19	Deck cranes	Grab or magnet	A4 - A5
20	Tower cranes for building		A3 - A4
21	Derricks		A2 - A3
22	Railway cranes allowed to run in train		A4

(1) Only a few typical cases of use are shown, by way of guidance, in this column.

2.1.3.2. CLASSES OF UTILIZATION

By duration of use of a mechanism is meant the time during which the mechanism is actually in motion.

The total duration of use is a calculated duration of use, considered as a guide value, applying up to the time of replacement of the mechanism. It is expressed in terms of hours.

On the basis of this total duration of use, we have ten classes of utilization, T0, T1, T2, ..., T9. They are defined in table T.2.1.3.2.

Table T.2.1.3.2.
Classes of utilization

Symbol	Total duration of use T (h)				
T0			T	≤	200
T1	200	<	T	≤	400
T2	400	<	T	≤	800
T3	800	<	T	≤	1 600
T4	1 600	<	T	≤	3 200
T5	3 200	<	T	≤	6 300
T6	6 300	<	T	≤	12 500
T7	12 500	<	T	≤	25 000
T8	25 000	<	T	≤	50 000
T9	50 000	<	T		

2.1.3.3. LOADING SPECTRUM

The loading spectrum characterizes the magnitude of the loads acting on a mechanism during its total duration of use. It is a distribution function (summed) $y = f(x)$, expressing the fraction x ($0 < x \leq 1$) of the total duration of use, during which the mechanism is subjected to a loading attaining at least a fraction y ($0 \leq y \leq 1$) of the maximum loading (see figure 2.1.2.3.1.).

Each spectrum is assigned a spectrum factor k_m , defined by :

$$k_m = \int_0^1 y^d dx$$

For the purposes of group classification, d is taken by convention as equal to 3.

In many applications the function $f(x)$ may be approximated by a function consisting of a certain number r of steps (see fig. 2.1.2.3.2.), of respective durations t_1, t_2, \dots, t_r ; the loadings S may be considered as practically constant and equal to S_i during the duration t_i . If T represents the total duration of use and S_{max} the greatest of the loadings S_1, S_2, \dots, S_r , there exists a relation :

$$t_1 + t_2 + \dots + t_r = \sum_{i=1}^r t_i = T$$

and in approximated form :

$$k_m = \left(\frac{S_1}{S_{max}}\right)^3 \frac{t_1}{T} + \left(\frac{S_2}{S_{max}}\right)^3 \frac{t_2}{T} + \dots + \left(\frac{S_r}{S_{max}}\right)^3 \frac{t_r}{T} = \sum_{i=1}^r \left(\frac{S_i}{S_{max}}\right)^3 \frac{t_i}{T}$$

Depending on its loading spectrum, a mechanism is placed in one of the four spectrum classes L1, L2, L3, L4, defined in table T.2.1.3.3.

Table T.2.1.3.3.

Spectrum classes

Symbol	Spectrum factor k_m			
L1			$k_m \leq$	0.125
L2	0.125	<	$k_m \leq$	0.250
L3	0.250	<	$k_m \leq$	0.500
L4	0.500	<	$k_m \leq$	1.000

2.1.3.4. GROUP CLASSIFICATION OF INDIVIDUAL MECHANISMS AS A WHOLE

On the basis of their class of utilization and their spectrum class, individual mechanisms as a whole are classified in one of the eight groups M1, M2, ..., M8 defined in table T.2.1.3.4.

Table T.2.1.3.4.

Mechanism groups

Class of load spectrum	Class of utilization									
	T0	T1	T2	T3	T4	T5	T6	T7	T8	T9
L1	M1	M1	M1	M2	M3	M4	M5	M6	M7	M8
L2	M1	M1	M2	M3	M4	M5	M6	M7	M8	M8
L3	M1	M2	M3	M4	M5	M6	M7	M8	M8	M8
L4	M2	M3	M4	M5	M6	M7	M8	M8	M8	M8

2.1.3.5. GUIDANCE FOR GROUP CLASSIFICATION OF INDIVIDUAL MECHANISMS AS A WHOLE

Guidance for group classification of an individual mechanism as a whole is given in table T.2.1.3.5.

Since appliances of the same type may be used in a wide variety of ways, the grouping directions in this table can only be taken as a model. In particular, where several groups are shown as appropriate to a mechanism of a given type, it is necessary to ascertain, on the basis of the mechanism's calculated total duration of use and loading spectrum, in which class of utilization (see 2.1.3.2.) and spectrum (see 2.1.3.3.) it has to be placed, and consequently in which group of mechanisms (see 2.1.3.4.).

Table T.2.1.3.5.

Guidance for group classification of a mechanism

Type of appliance		Particulars concerning nature of use (1)	Type of mechanism				
Reference	Designation		Hoisting	Slewing	Luffing	Traverse	Travel
1	Hand-operated appliances		M1	-	-	M1	M1
2	Erection cranes		M2-M3	M2-M3	M1-M2	M1-M2	M2-M3
3	Erection and dismantling cranes for power stations, machine shops, etc.		M2	-	-	M2	M2
4	Stocking and reclaiming transporters	Hook duty	M5-M6	M4	-	M4-M5	M5-M6
5	Stocking and reclaiming transporters	Grab or magnet	M7-M8	M6	-	M6-M7	M7-M8
6	Workshop cranes		M6	M4	-	M4	M5
7	Overhead travelling cranes, pig-breaking cranes, scrapyards cranes	Grab or magnet	M8	M6	-	M6-M7	M7-M8
8	Ladle cranes		M7-M8	-	-	M4-M5	M6-M7
9	Soaking-pit cranes		M8	M6	-	M7	M8
10	Stripper cranes, open-hearth furnace-charging cranes		M8	M6	-	M7	M8
11	Forge cranes		M8	-	-	M5	M6
12.a	Bridge cranes for unloading, bridge cranes for containers	a. Hook or spreader duty	M6-M7	M5-M6	M3-M4	M6-M7	M4-M5
12.b	Other bridge cranes (with crab and/or slewing jib crane)	b. Hook duty	M4-M5	M4-M5	-	M4-M5	M4-M5
13	Bridge cranes for unloading, bridge cranes (with crab and/or slewing jib crane)	Grab or magnet	M8	M5-M6	M3-M4	M7-M8	M4-M5
14	Drydock cranes, shipyard jib cranes, jib cranes for dismantling	Hook duty	M5-M6	M4-M5	M4-M5	M4-M5	M5-M6
15	Dockside cranes (slewing, on gantry, etc.), floating cranes and pontoon derricks	Hook duty	M6-M7	M5-M6	M5-M6	-	M3-M4
16	Dockside cranes (slewing, on gantry, etc.), floating cranes and pontoon derricks	Grab or magnet	M7-M8	M6-M7	M6-M7	-	M4-M5
17	Floating cranes and pontoon derricks for very heavy loads (usually greater than 100 t)		M3-M4	M3-M4	M3-M4	-	-
18	Deck cranes	Hook duty	M4	M3-M4	M3-M4	M2	M3
19	Deck cranes	Grab or magnet	M5-M6	M3-M4	M3-M4	M4-M5	M3-M4
20	Tower cranes for building		M4	M5	M4	M3	M3
21	Derricks		M2-M3	M1-M2	M1-M2	-	-
22	Railway cranes allowed to run in train		M3-M4	M2-M3	M2-M3	-	-

(1) Only a few typical cases of use are shown, by way of guidance, in this column.

2.1.4.1. CLASSIFICATION SYSTEM

Components, both structural and mechanical, are classified in eight groups, designed respectively by the symbols E1, E2, ..., E8, on the basis of eleven classes of utilization and four classes of stress spectrum.

2.1.4.2. CLASSES OF UTILIZATION

By duration of use of a component is meant the number of stress cycles to which the component is subjected.

A stress cycle is a complete set of successive stresses, commencing at the moment when the stress under consideration exceeds the stress σ_m defined in fig. 2.1.4.3. and ending at the moment when this stress is, for the first time, about to exceed again σ_m in the same direction. Fig. 2.1.4.3. therefore represents the trend of the stress σ over a duration of use equal to five stress cycles.

The total duration of use is a computed duration of use, considered as a guide value, applying up to the time of replacement of the component.

In the case of structural components the number of stress cycles is in a constant ratio with the number of hoisting cycles of the appliance. Certain components may be subjected to several stress cycles during a hoisting cycle depending on their position in the structure. Hence the ratio in question may differ from one component to another. Once this ratio is known, the total duration of use of the component is derived from the total duration of use which determined the class of utilization of the appliance.

As regards mechanical components, the total duration of use is derived from the total duration of use of the mechanism to which the component under consideration belongs, account being taken of its speed of rotation and/or other circumstances affecting its operation.

On the basis of the total duration of use, we have eleven classes of utilization, designated respectively by the symbols B0, B1, ..., B10. They are defined in table T.2.1.4.2.

Table T.2.1.4.2.

Classes of utilization

Symbol	Total duration of use (number n of stress cycles)			
B0			$n \leq$	16 000
B1	16 000	<	$n \leq$	32 000
B2	32 000	<	$n \leq$	63 000
B3	63 000	<	$n \leq$	125 000
B4	125 000	<	$n \leq$	250 000
B5	250 000	<	$n \leq$	500 000
B6	500 000	<	$n \leq$	1 000 000
B7	1 000 000	<	$n \leq$	2 000 000
B8	2 000 000	<	$n \leq$	4 000 000
B9	4 000 000	<	$n \leq$	8 000 000
B10	8 000 000	<	n	

2.1.4.3. STRESS SPECTRUM

The stress spectrum characterizes the magnitude of the load acting on the component during its total duration of use. It is a distribution function (summed) $y = f(x)$, expressing the fraction x ($0 \leq x \leq 1$) of the total duration of use (see 2.1.4.2.), during which the component is subjected to a stress attaining at least a fraction y ($0 \leq y \leq 1$) of the maximum stress.

Each stress spectrum is assigned a spectrum factor k_{sp} , defined by

$$k_{sp} = \int_0^1 y^c dx$$

Where c is an exponent depending on the properties of the material concerned, the shape and size of the component in question, its surface roughness and its degree of corrosion (see booklet 4).

In many applications the function $f(x)$ may be approximated by a function consisting of a certain number r of steps, comprising respectively n_1, n_2, \dots, n_r stress cycles. The stress σ may be considered as practically constant and equal to σ_i during n_i cycles. If n represents the total duration of use and σ_{max} the greatest of the stresses $\sigma_1, \sigma_2, \dots, \sigma_r$ there exists a relation :

$$n_1 + n_2 + \dots + n_r = \sum_{i=1}^r n_i = n$$

and in approximated form :

$$k_{sp} = \left(\frac{\sigma_1}{\sigma_{max}}\right)^c \frac{n_1}{n} + \left(\frac{\sigma_2}{\sigma_{max}}\right)^c \frac{n_2}{n} + \dots + \left(\frac{\sigma_r}{\sigma_{max}}\right)^c \frac{n_r}{n} = \sum_{i=1}^r \left(\frac{\sigma_i}{\sigma_{max}}\right)^c \frac{n_i}{n}$$

Depending on its stress spectrum, a component is placed in one of the spectrum classes P1, P2, P3, P4, defined in table T.2.1.4.3. (1).

Table T.2.1.4.3.

Spectrum classes

Symbol	Spectrum factor k_{sp}			
P1			$k_{sp} \leq$	0.125
P2	0.125	<	$k_{sp} \leq$	0.250
P3	0.250	<	$k_{sp} \leq$	0.500
P4	0.500	<	$k_{sp} \leq$	1.000

(1) There are components, both structural and mechanical, such as spring loaded components, which are subjected to loading that is quite or almost independent of the working load. Special care shall be taken in classifying such components. In most cases $k_{sp} = 1$ and they belong to class P4.

For structural components, the stresses to be taken into consideration for determination of the spectrum factor are the differences $\sigma_{\text{sup}} - \sigma_m$ between the upper stresses σ_{sup} and the average stress σ_m , these concepts being defined by fig. 2.1.4.3. representing the variation of the stress over time during five stress cycles.

Fig. 2.1.4.3. - Variation of stress as a function of time during five stress cycles

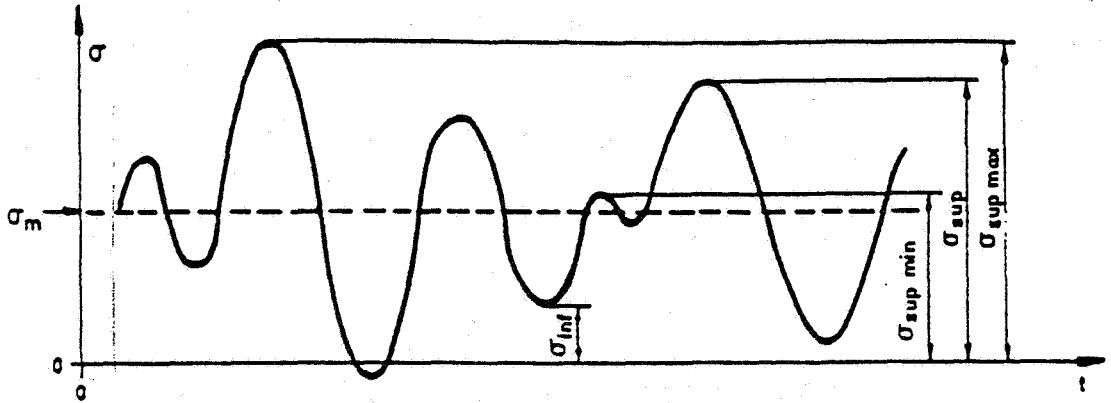

- σ_{sup} = upper stress
- $\sigma_{\text{sup max}}$ = maximum upper stress
- $\sigma_{\text{sup min}}$ = minimum upper stress
- σ_{inf} = lower stress
- σ_m = arithmetic mean of all upper and lower stresses during the total duration of use

In the case of mechanical components, we can put $\sigma_m = 0$ the stresses to be introduced into the calculation of the spectrum factor then being the total stresses occurring in the relevant section of the component.

2.1.4.4. **GROUP CLASSIFICATION OF COMPONENTS**

On the basis of their class of utilization and their stress spectrum class, components are classified in one of the eight groups E1, E2, ..., E8, defined in table T.2.1.4.4.

Table T.2.1.4.4.

Component groups

Stress Spectrum class	Class of utilization										
	B0	B1	B2	B3	B4	B5	B6	B7	B8	B9	B10
P1	E1	E1	E1	E1	E2	E3	E4	E5	E6	E7	E8
P2	E1	E1	E1	E2	E3	E4	E5	E6	E7	E8	E8
P3	E1	E1	E2	E3	E4	E5	E6	E7	E8	E8	E8
P4	E1	E2	E2	E4	E5	E6	E7	E8	E8	E8	E8

LOADS ENTERING INTO THE DESIGN OF STRUCTURES

The structural calculations shall be conducted by determining the stresses developed in an appliance during its operation. These stresses shall be calculated on the basis of the loads defined below :

- a) The principal loads exerted on the structure of the appliance, assumed to be stationary, in the most unfavourable state of loading ;
- b) Loads due to vertical motions ;
- c) Loads due to horizontal motions ;
- d) Loads due to climatic effects.

The various loads, the factors to be applied, and the practical method of conducting the calculations are examined below.

In what follows, the definitions given below are used :

Working load : Weight of the useful load lifted, plus the weight of the accessories (sheave blocks, hooks, lifting beams, grab, etc.)

Dead load : Dead weight of components acting on a given member, excluding the working load.

2.2.1.

PRINCIPAL LOADS

The principal loads include :

- the loads due to the dead weight of the components : S_G
- the loads due to the working load : S_L

all movable parts being assumed to be in their most unfavourable position.

Each structural member shall be designed for the position of the appliance and magnitude of the working load (between zero and the safe working load) which gives rise to the maximum stresses (1) in the member in question.

2.2.2.

LOADS DUE TO VERTICAL MOTIONS

These loads stem from picking up the working load more or less suddenly, from accelerations (or decelerations) of the hoisting motion, and from vertical shock loadings due to travelling along rail tracks.

(1)

In certain cases, the maximum stress may be obtained with no working load.

2.2.2.1. LOADS DUE TO HOISTING OF THE WORKING LOAD

Account shall be taken of the oscillations caused when lifting the load by multiplying the loads due to the working load by a factor called the "dynamic coefficient Ψ ".

2.2.2.1.1. VALUES OF THE DYNAMIC COEFFICIENT Ψ

The value of the dynamic coefficient Ψ to be applied to the load arising from the working load is given by the expression :

$$\Psi = 1 + \xi v_L$$

where v_L is the hoisting speed in m/s.

and ξ an experimentally determined coefficient (1).

The following values shall be adopted :

$\xi = 0,6$ for overhead travelling cranes and bridge cranes

$\xi = 0,3$ for jib cranes.

The maximum figure to be taken for the hoisting speed when applying this formula is 1 m/s. For higher speeds, the dynamic coefficient Ψ is not further increased.

The value to be applied for the coefficient Ψ in the calculations shall in no case be less than 1,15.

The values of Ψ are given in the curves of figure 2.2.2.1.1. in terms of hoisting speeds v_L .

Figure 2.2.2.1.1.

Values of dynamic coefficient Ψ

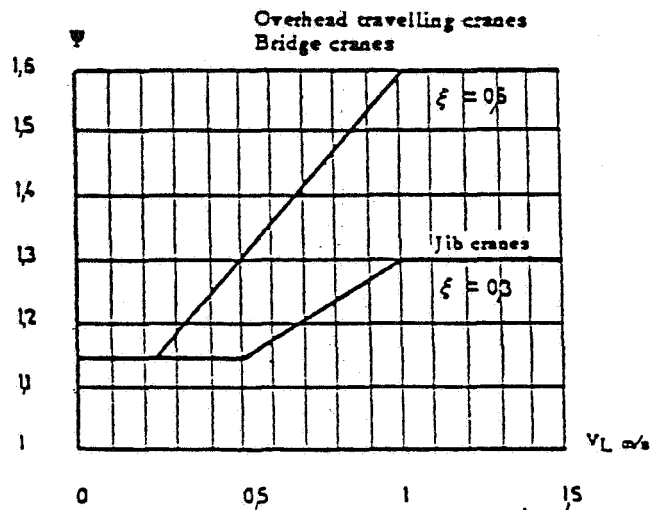

(1) The figure given for this coefficient ξ is the result of a large number of measurements made on different types of appliances.

Note - The above mentioned coefficient ξ is not the same for "overhead travelling cranes and bridge cranes" and for "jib cranes".

The difference arises from the fact that the dynamic coefficient Ψ is, other things being equal, smaller when the hoisting load is carried by a member having some flexibility, as in jib cranes where the jib is never rigid.

In a similar way, use of the coefficient Ψ as indicated for jib cranes may be extended to certain other appliances such as, for example, transporters for the design case corresponding to load on the cantilever boom ; the value of Ψ indicated for overhead travelling cranes should, of course, be used for the design cases where the load is applied between the legs of the machine as the rigidity of the structure at this point is comparable with that one of an overhead travelling crane girder.

2.2.2.2. LOADS DUE TO ACCELERATION (OR DECELERATION) OF THE HOISTING MOTION AND TO VERTICAL SHOCK LOADINGS WHEN TRAVELLING ALONG RAIL TRACKS

Since the coefficient Ψ takes account of the degree of snatch on the working load which is the largest shock loading, loads due to acceleration (or deceleration) of the hoisting motion and the vertical reactions due to travelling along tracks, assumed to be properly laid, shall be neglected (1).

2.2.2.3. SPECIAL CASE

In the case of certain appliances, the loads due to the dead loads are of opposite sign to those due to the working load, in which case a comparison must be made between the loading figure obtained in the "appliance under load" condition, with the dynamic coefficient Ψ applied to the working load, and the loading figure obtained in the "no-load" condition, taking into account the oscillations resulting from setting down the load, as follows :

Let :

\bar{S}_G be the algebraic value of the loads due to the dead load

\bar{S}_L be the algebraic value of the loads due to the working load.

The amplified total load, when setting down the load is obtained by the expression

$$\bar{S}_G - \bar{S}_L \left(\frac{\Psi - 1}{2} \right)$$

which is compared with the load for the "appliance under load" condition determined by the expression :

$$\bar{S}_G + \Psi \bar{S}_L$$

the component being finally designed on the basis of the more unfavourable of these two values.

(1) This assumes that the rail joints are in good condition. The detrimental effect on hoisting appliances of rail tracks in poor condition is so great, both for the structure and the machinery, that it is necessary to stipulate that the rail joints must be maintained in good condition : no shock loading coefficient can allow for the damage caused by faulty joints. In so far as high speed appliances are concerned, the best solution is to butt-weld the rails, in order to eliminate entirely the shock loadings which occur when an appliance runs over joints.

Note - This formula is based on the fact that the dynamic coefficient determines the maximum amplitude of the oscillations set up in the structure when the load is picked up. The amplitude of the oscillation is given by :

$$\bar{S}_L (\Psi - 1)$$

It is assumed that the amplitude of the oscillation set up in the structure when the load is set down is half that of the oscillation caused when hoisting takes place.

The ultimate state of loading is therefore :

$$\bar{S}_G - \bar{S}_L \left(\frac{\Psi - 1}{2} \right)$$

which must be compared with the state of loading given by :

$$\bar{S}_G + \Psi \bar{S}_L$$

Hoisting and lowering curve when S_L and S_G are of opposite sign

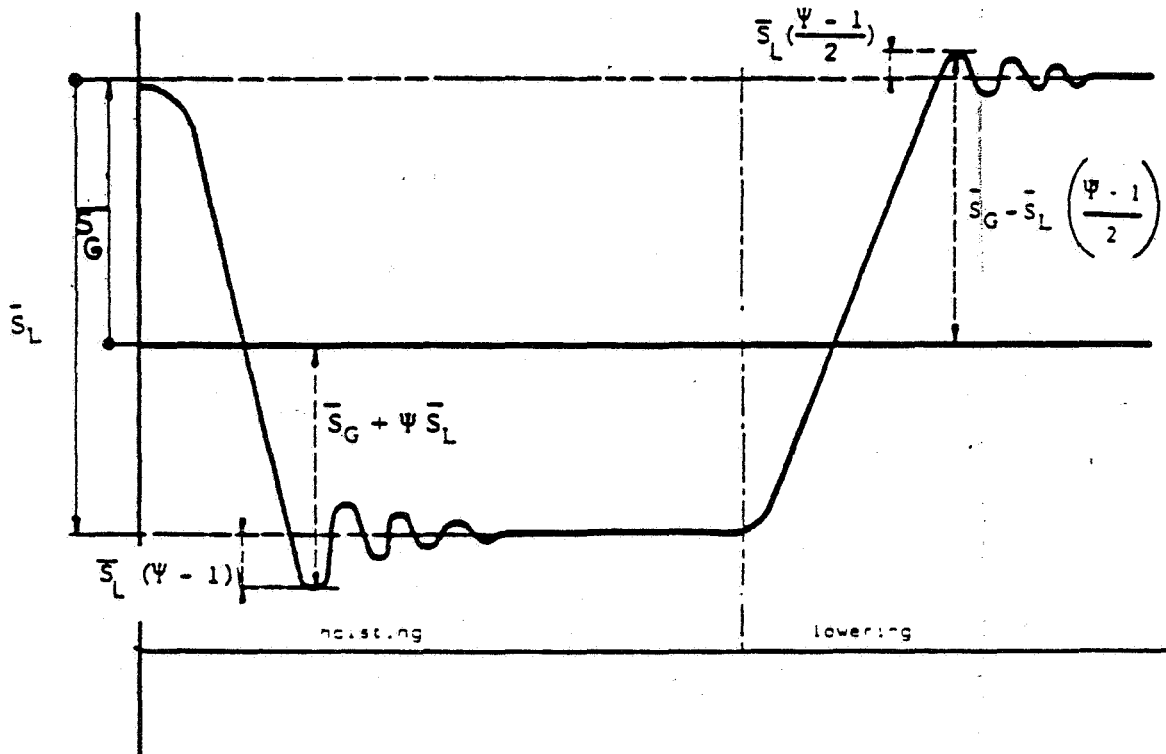

2.2.3.

LOADS DUE TO HORIZONTAL MOTIONS S_H

The loads due to horizontal motions are as follows :

- 1) The inertia effects due to acceleration (or deceleration) of the traverse, travel, slewing or luffing motions. These effects can be calculated in terms of the value of the acceleration (or deceleration).
- 2) The effects of centrifugal force.
- 3) Transverse horizontal reactions resulting from rolling action.
- 4) Buffer effects.

2.2.3.1. HORIZONTAL EFFECTS DUE TO ACCELERATION (OR DECELERATION)

The loads due to the accelerations (or decelerations) imparted to the movable elements when starting or braking are calculated for the various structural members.

2.2.3.1.1. TRAVERSE AND TRAVEL MOTIONS

For these motions the calculation is made by considering a horizontal force applied at the tread of the driven wheels parallel to the rail.

The loads shall be calculated in terms of the acceleration (or deceleration) time assumed according to the working conditions and the speeds to be attained.

From it is deduced the value (in m/s^2) of the acceleration to be used for calculating the horizontal force according to the masses to be set in motion.

Note - If the speed and acceleration values are not specified by the user, acceleration times corresponding to the speeds to be reached may be chosen according to the three following working conditions :

- a) Appliances of low and moderate speed with a great length of travel ;
- b) Appliances of moderate and high speed for normal applications ;
- c) High speed appliances with high acceleration.

In the latter case, it is almost always necessary to drive all the rail wheels.

Table T.2.2.3.1.1. gives the values of acceleration times and accelerations for the three conditions.

Table T.2.2.3.1.1.

Acceleration time and acceleration value

Speed to be reached m/s	(a) low and moderate speed with long travel		(b) moderate and high speed (normal applications)		(c) high speed with high accelerations	
	Acceleration time s	Acceleration m/s ²	Acceleration time s	Acceleration m/s ²	Acceleration time s	Acceleration m/s ²
4,00			8,0	0,50	6,0	0,67
3,15			7,1	0,44	5,4	0,58
2,5			6,3	0,39	4,8	0,52
2	9,1	0,22	5,6	0,35	4,2	0,47
1,60	8,3	0,19	5,0	0,32	3,7	0,43
1,00	6,6	0,15	4,0	0,25	3,0	0,33
0,63	5,2	0,12	3,2	0,19		
0,40	4,1	0,098	2,5	0,16		
0,25	3,2	0,078				
0,16	2,5	0,064				

The horizontal force to be taken into account shall be not less than 1/30th nor more than 1/4 of the load on the driven or braked wheels.

2.2.3.1.2. SLEWING AND LUFFING (DERRICKING) MOTIONS

For slewing and luffing motions the calculations shall be based on the accelerating (or decelerating) torque applied to the motor shaft of the mechanisms.

The rates of acceleration will depend upon the appliance ; for a normal crane a value between 0.1 m/s² and 0.6 m/s², according to the speed and radius, may be chosen for the acceleration at the jib head so that an acceleration time of from 5 to 10 s is achieved.

Note - A method for calculating the effects of acceleration of horizontal motions is given in appendix A.2.2.3.

2.2.3.2. EFFECTS OF CENTRIFUGAL FORCE

In the case of jib cranes, account shall be taken of the centrifugal force due to slewing. In practice, it is sufficient to determine the horizontal force exerted at the jib head as a result of the inclination of the rope carrying the load and in general to neglect the effects of centrifugal force on the other elements of the crane.

2.2.3.3. TRANSVERSE REACTIONS DUE TO ROLLING ACTION

When two wheels (or two bogies) roll along a rail, the couple formed by the horizontal forces normal to the rail shall be taken into consideration. The components of this couple are obtained by multiplying the vertical load exerted on the wheels (or bogies) by a coefficient λ which depends upon the ratio of the span p to the wheel base a (1).

(1) By "wheelbase" is understood the centre distance between the outermost pairs of wheels, or, in the case of bogies, the centre distance between the fulcrum pins on the crane structure of the two bogies or bogie systems. Where horizontal guiding wheels are provided, the wheelbase shall be the distance between the rail contact points of two horizontal wheels.

As shown in the graph, this coefficient lies between 0.05 and 0.2 for ratios of $\frac{P}{a}$ between 2 and 8.

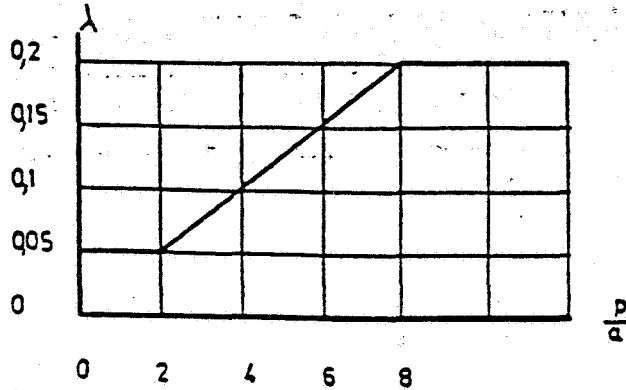

2.2.3.4. BUFFER EFFECTS S_T

The case must be considered when the impact due to collision with buffers is applied to the structure, and the case when it is applied to the suspended load.

2.2.3.4.1. BUFFER EFFECTS ON THE STRUCTURE

A distinction must be drawn between :

- 1) the case in which the suspended load can swing.
- 2) that in which rigid guides prevent swing.

In the first case the following rules shall be applied :

For horizontal speeds below 0.7 m/sec, no account shall be taken of buffer effects.

For speeds in excess of 0.7 m/sec, account must be taken of the reactions set up in the structure by collisions with buffers.

It shall be assumed that a buffer is capable of absorbing the kinetic energy of the appliance (without the working load) at a fraction of the rated speed V_t fixed at $0.7 V_t$.

The resulting loads set up in the structure shall be calculated on the basis of the retardation imparted to the appliance by the buffer in use.

However, for higher speeds (greater than 1 m/sec), the use of decelerating devices which act upon approach to the ends of the track is permitted provided the action of these devices is automatic and they produce an effective deceleration of the appliance which always reduces the speed to the predetermined lower value before the buffers are reached.

In this case the reduced speed obtained after slowing down is used for the value of V_t when calculating the buffer effect (1).

In the second case where the load cannot swing the buffer effect is calculated in the same manner but taking account of the value of the working load.

(1) It must be emphasised that a sure and effective device must be fitted. A mere end-of-travel limit switch cutting off the power supply to the motor is not sufficient reason to assume reduced speed for the buffer effect.

2.2.3.4.2. BUFFER EFFECTS ON THE SUSPENDED LOAD

Impacts due to collision between the load and fixed obstructions are taken into account only for appliances where the load is rigidly guided. In that case, the loads generated by such a collision are to be taken into consideration.

The loads can be computed by considering that horizontal force applied at the level of the load which is capable of causing two of the crab wheels to lift.

2.2.4. LOADS DUE TO CLIMATIC EFFECTS

The loads due to climatic effects are those resulting from the action of the wind, from snow loads and from temperature variations.

2.2.4.1. WIND ACTION

INTRODUCTION

This clause relates to wind loads on crane structure.

It gives a simplified method of calculation and assumes that the wind can blow horizontally from any direction, that the wind blows at a constant velocity and that there is a static reaction to the loadings it applies to the crane structure.

2.2.4.1.1. WIND PRESSURE

The dynamic wind pressure is given by :

$$q = 0.613 V_s^2$$

Where q is the dynamic pressure N/m^2 .

V_s is the design wind speed in m/s.

2.2.4.1.2. DESIGN WIND CONDITIONS

Two design wind conditions are taken into account in calculating wind loads on cranes.

2.2.4.1.2.1. In-service wind

This is the maximum wind in which the crane is designed to operate. The wind loads are assumed to be applied in the least favourable direction in combination with the appropriate service loads. In-service design wind pressures and corresponding speeds are given in table T.2.2.4.1.2.1. They are assumed to be constant over the height of the appliance (1).

It is assumed that the operating speeds and nominal accelerations are not necessarily reached under extreme wind conditions.

(1) Where a wind speed measuring device is to be attached to an appliance it shall normally be placed at the maximum height of the appliance. In cases where the wind speed at a different level is more significant to the safety of the appliance, the manufacturer shall state the height at which the device shall be placed.

Table T.2.2.4.1.2.1.

In-service design wind pressure

Type of appliance	Wind pressure in service N/m ²	Wind speed in service m/s
Lifting appliance easily protected against wind action or designed for use exclusively in light wind. Erection operations.	125	14
All normal types of crane installed in the open	250	20
* Appliances which must continue to work in high winds	500	28

* For example appliances of type 12a in table T.2.1.2.5.

Action of wind on the load

The action of the wind on the hook load for a crane which handles miscellaneous loads shall be determined from the relationship :

$$F = 2.5 A \times q$$

where

F is the force exerted by the wind on the hook load in N,

q is the in-service wind pressure from table 2.2.4.1.2.1. in N/m²,

A is the maximum area of the solid parts of the hook load in m² (1). where this area is not known, a minimum value of 0.5 m² per tonne of safe working load shall be used.

Where a crane is designed to handle loads of a specific size and shape only, the wind loading shall be calculated for the appropriate dimensions and configurations.

2.2.4.1.2.2. Wind out of service

This is a maximum (storm) wind for which the lifting machine is designed to remain stable in out of service conditions, as indicated, by the manufacturer. The speed varies with the height of the apparatus above the surrounding ground level, the geographical location and the degree of exposure to the prevailing winds.

For lifting appliances used in the open air, the normal theoretical wind pressure and the corresponding speed, for "out of service" conditions are indicated in the table T.2.2.4.1.2.2.

- (1) where, exceptionally, a crane is required to handle loads of large surface area, it is admissible for the manufacturer to determine a wind speed less than that specified in table T.2.2.4.1.2.1. above which such loads shall not be handled.

Table T.2.2.4.1.2.2.

Out of service wind

Height above ground level m	Out of service design wind pressure N/m ²	Approximate equivalent out of service design wind speed m/s
0 to 20	800	36
20 to 100	1 100	42
More than 100	1 300	46

When calculating wind loads for out of service conditions the wind pressure may be taken as constant over the vertical height intervals in table T.2.2.4.1.2.2. Alternatively, the design wind pressure at the top of the crane may be assumed constant over its entire height.

Where cranes are to be permanently installed or used for extended periods in areas where wind conditions are exceptionally severe, the above figures may be modified by agreement between the manufacturer and purchaser in the light of local meteorological data.

For certain types of appliance of which the jib can be quickly lowered, (such as a tower crane which can be easily lowered by a built-in mechanism) the out of service wind need not be taken into consideration provided the machine is intended for lowering after each working day.

2.2.4.1.3. WIND LOAD CALCULATIONS

For most complete and part structures, and individual members used in crane structures the wind load is calculated from :

$$F = A \cdot q \cdot C_f$$

where

F is the wind load in N,

A is the effective frontal area of the part under consideration in m²,

q is the wind pressure corresponding to the appropriate design condition in N/m²,

C_f is the shape coefficient in the direction of the wind for the part under consideration.

The total wind load on the structure is taken as the sum of the loads on its component parts.

In determining strength and stability requirements of the appliance the total wind load shall be considered.

The magnitude of the wind load to be allowed for in the design of a mechanism, in determining the motor and brake requirements for the mechanism and to provide for the safety of the appliance in the wind, are given in the chapter dealing with the design of mechanisms.

2.2.4.1.4. SHAPE COEFFICIENTS

2.2.4.1.4.1. Individual members, frames, etc.

Shape coefficients for individual members, single lattice frames and machinery houses are given in table T.2.2.4.1.4.1. The values for individual members vary according to the aerodynamic slenderness and, in the case of large box sections, with the section ratio. Aerodynamic slenderness and section ratio are defined in figure 2.2.4.1.4.1.

The wind load on single lattice frames may be calculated on the basis of the coefficients for the individual members given in the top part of table T.2.2.4.1.4.1. In this case the aerodynamic slenderness of each member shall be taken into account. Alternatively the overall coefficients for lattice frames constructed of flat sided and circular sections given in the middle part of the table may be used.

Where a lattice frame is made up of flat-sided and circular sections, or of circular sections in both flow regimes ($D \cdot V_S < 6 \text{ m}^2/\text{s}$ and $D \cdot V_S > 6 \text{ m}^2/\text{s}$) the appropriate shape coefficients are applied to the corresponding frontal areas.

Where gusset plates of normal size are used in welded lattice construction no allowance for the additional area presented by the plates is necessary, provided the lengths of individual members are taken between the centres of node points.

Shape coefficients obtained from wind-tunnel or full-scale tests may also be used.

T.2.2.4.1.4.1.

Force coefficients

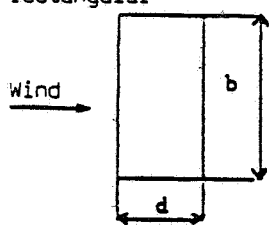
Type	Description	Aerodynamic Slenderness l/b or l/D (1)						
		≤ 5	10	20	30	40	50	> 50
Individual members	Rolled sections []	1,15	1,15	1,3	1,4	1,45	1,5	1,6
	Rectangular hollow sections up to 356 mm square	1,4	1,45	1,5	1,55	1,55	1,55	1,6
	and 254 x 457 mm rectangular	1,05	1,05	1,2	1,3	1,4	1,5	1,6
	Other sections	1,30	1,35	1,60	1,65	1,70	1,80	1,80
	Circular sections where :							
	D·Vs $< 6 \text{ m}^2/\text{s}$ D·Vs $\geq 6 \text{ m}^2/\text{s}$	0,60 0,60	0,70 0,65	0,80 0,70	0,85 0,70	0,90 0,75	0,90 0,80	0,90 0,80
Rectangular hollow sections over 356 mm square and 254 x 457 mm rectangular	b/d							
	2	1,55	1,75	1,95	2,10	2,20		
	1	1,40	1,55	1,75	1,85	1,90		
	0,5 0,25	1,0 0,80	1,20 0,90	1,30 0,90	1,35 1,0	1,40 1,0		
								
Single lattice frames	Flat-sided sections	1,70						
	Circular sections where : D·Vs $< 6 \text{ m}^2/\text{s}$ D·Vs $\geq 6 \text{ m}^2/\text{s}$	1,10 0,80						
Machinery houses etc.	Rectangular clad structures on ground or solid base	1,10						

(1) See figure 2.2.4.1.4.1.

(I) Aerodynamic slenderness : $\frac{\text{length of member}}{\text{breadth of section across wind front}} = \frac{l^*}{b}$ or $\frac{l^*}{D}$

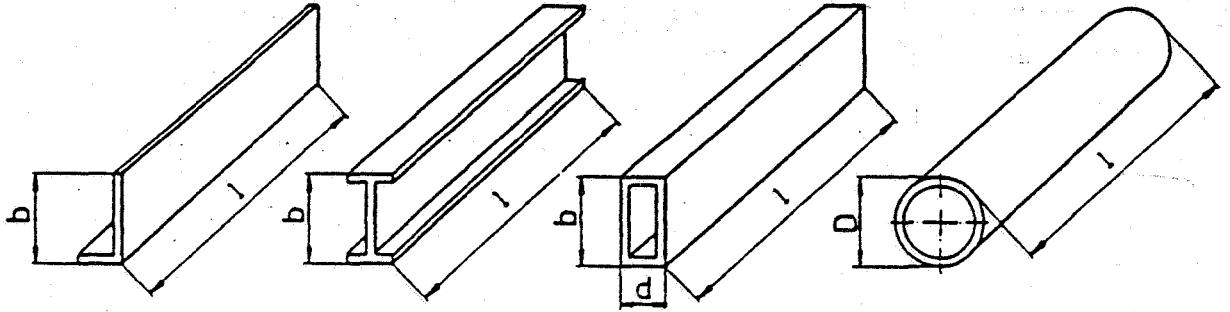

* In lattice construction the lengths of individual members are taken between the centres of adjacent node points. See diagram below

(II) Solidity ratio = $\frac{\text{area of solid parts}}{\text{enclosed area}} = \frac{A}{A_e} = \frac{\sum_{i=1}^n l_i \times b_i}{L \times B}$

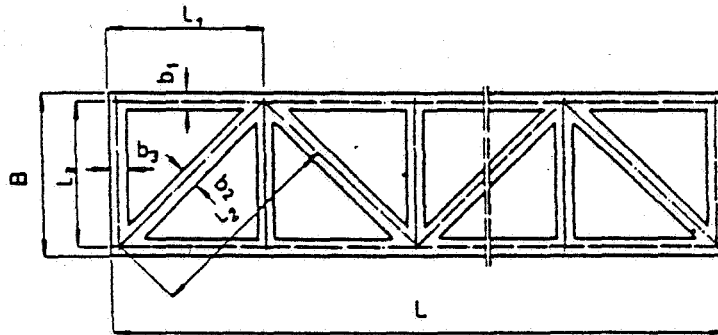

(III) Spacing ratio = $\frac{\text{distance between facing sides}}{\text{breadth of members across wind front}} = \frac{a}{b}$ or $\frac{a}{B}$

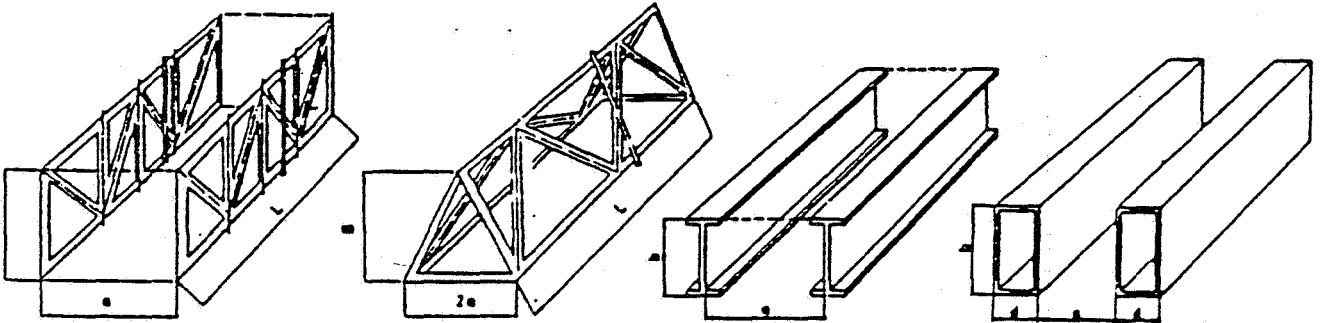

for "a" take the smallest possible value in the geometry of the exposed face.

(IV) Section ratio = $\frac{\text{breadth of section across wind front}}{\text{depth of section parallel to wind flow}} = \frac{B}{D}$

Figure 2.2.4.1.4.1.

Definitions : Aerodynamic Slenderness, Solidity Ratio, Spacing Ratio, and Section Ratio

2.2.4.1.4.2. Multiple frames of members : shielding factors

Where parallel frames or members are positioned so that shielding takes place, the wind loads on the windward frame or member and on the unsheltered parts of those behind it are calculated using the appropriate shape coefficients. The wind load on the sheltered parts is multiplied by a shielding factor η given in table T.2.2.4.1.4.2. Values of η vary with the solidity and spacing ratios as defined in figure 2.2.4.1.4.1.

Table T.2.2.4.1.4.2.

Shielding coefficients

Spacing ratio a/b	Solidity ratio A/A _e					
	0.1	0.2	0.3	0.4	0.5	≥ 0.6
0.5	0.75	0.40	0.32	0.21	0.15	0.10
1.0	0.92	0.75	0.59	0.43	0.25	0.10
2.0	0.95	0.80	0.63	0.50	0.33	0.20
4.0	1.0	0.88	0.76	0.66	0.55	0.45
5.0	1.0	0.95	0.88	0.81	0.75	0.68
6.0	1.0	1.0	1.0	1.0	1.0	1.0

Where a number of identical frames or members are spaced equidistantly behind each other in such a way that each frame shields those behind it, the shielding effect is assumed to increase up to the ninth frame and to remain constant thereafter.

The wind loads are calculated as follows :

On the 1st. frame $F_1 = A \cdot q \cdot C_f$ in N

On the 2nd. frame $F_2 = \eta \cdot A \cdot q \cdot C_f$ in N

On the nth frame
(where n is from 3 to 8) $F_n = \eta^{(n-1)} \cdot A \cdot q \cdot C_f$ in N

On the 9th and subsequent frames $F_9 = \eta^3 \cdot A \cdot q \cdot C_f$ in N

The total wind load is thus :

Where there are up to 9 frames $F_{total} = [1 + \eta + \eta^2 + \eta^3 + \dots + \eta^{(n-1)}] \cdot A \cdot q \cdot C_f$
 $= A \cdot q \cdot C_f \left(\frac{1 - \eta^n}{1 - \eta} \right)$ in N

Where there are more than 9 frames

$$F_{total} = [1 + \eta + \eta^2 + \eta^3 + \dots + \eta^3 + (n-9) \cdot \eta^3] \cdot A \cdot q \cdot C_f$$

$$= A \cdot q \cdot C_f \left[\left(\frac{1 - \eta^9}{1 - \eta} \right) + (n-9) \cdot \eta^3 \right]$$

Note - The term η^x used in the above formula is assumed to have a lower limit of 0.10. It is taken as 0.10 whenever $\eta^x < 0.10$.

2.2.4.1.4.3. Lattice towers

In calculating the "face-on" wind load on square towers, in the absence of a detailed calculation, the solid area of the windward face is multiplied by the following overall force coefficient :

For towers composed of flat sided sections	$1,7 \cdot (1 + \eta)$
For towers composed of circular sections	
where $D \cdot V_s < 6 \text{ m}^2/\text{s}$	$1,1 \cdot (1 + \eta)$
where $D \cdot V_s \geq 6 \text{ m}^2/\text{s}$	1,4

The value of η is taken from table 2.2.4.1.4.2. for $a/b = 1$ according to the solidity ratio of the windward face.

The maximum wind load on a square tower occurs when the wind blows on to a corner. In the absence of a detailed calculation, this load can be considered as 1.2 times that developed with "face-on" wind on one side.

2.2.4.1.4.4. Parts inclined in relation to the wind direction

Individual members, frames, etc.

Where the wind blows at an angle to the longitudinal axis of a member or to the surface of a frame, the wind load in the direction of the wind is obtained from :

$$F = A \cdot q \cdot C_f \sin^2 \Theta \quad \text{in N}$$

where F , A , q and C_f are as defined in 2.2.4.1.3. and Θ is the angle of the wind ($\Theta < 90^\circ$) to the longitudinal axis or face.

Lattice trusses and towers

Where the wind blows at an angle to the longitudinal axis of a lattice truss or tower, the wind load in the direction of the wind is obtained from :

$$F = A \cdot q \cdot C_f \cdot K_2 \quad \text{in N}$$

where F , A , q and C_f are as defined in 2.2.4.1.3. and $K_2 = \frac{\Theta}{50 (1,7 - \frac{S_0}{S})}$ which cannot be less than 0,35 or greater than 1.

where Θ is the angle of the wind in degrees ($\Theta < 90^\circ$) to the longitudinal axis of the truss or tower.

S_0 is the area in m^2 of the bracing members of the truss or tower projected on to its windward plane.

S is the area in m^2 of all (bracing and main) members of the truss or tower projected on to its windward plane.

The value of K_2 is assumed to have lower and upper limits of 0.35 and 1.0 respectively. It is taken as 0.35 whenever the calculated value < 0.35 and as 1.0 whenever the calculated value > 1.0 .

2.2.4.2. SNOW LOAD

Snow loads shall be neglected in the design calculations for overhead travelling cranes, bridge cranes and jib cranes.

2.2.4.3. TEMPERATURE VARIATIONS

Stresses due to temperature variations shall be considered only in special cases such as when members are not free to expand.

In such cases, the maximum temperature fluctuation shall be taken to be :

- 20° C to + 45° C.

2.2.5 MISCELLANEOUS LOADS

2.2.5.1. LOADS CARRIED BY PLATFORMS

Access gangways, driver's cabins and platforms shall be designed to carry the following concentrated loads :

3000 N for maintenance gangways and platforms where materials may be placed,

1500 N for gangways and platforms intended only for access of personnel,

300 N as the horizontal force which may be exerted on handrails and toe-guards.

These loads are not to be used in the calculations for girders.

2.3. CASES OF LOADING

Three different cases of loading are to be considered for the purpose of the calculations :

- the working case without wind,
- the working case with limiting working wind,
- the case of exceptional loadings.

Having determined the various loads in accordance with section 2.2, account is taken of a certain probability of exceeding the calculated stress, which results from imperfect methods of calculation and unforeseen contingencies, by applying an amplifying coefficient γ_c , which varies according to the group classification of the appliance.

The values of this coefficient γ_c are indicated in clause 2.3.4.

2.3.1.

CASE I : APPLIANCE WORKING WITHOUT WIND

The following shall be taken into consideration : the static loads due to the dead weight S_G , the loads due to the working load S_L multiplied by the dynamic coefficient Ψ , and the two most unfavourable horizontal effects S_H among those defined in clause 2.2.3., excluding buffer forces.

All these loads must then be multiplied by the amplifying coefficient Y_C specified in clause 2.3.4., viz :

$$Y_C (S_G + \Psi S_L + S_H)$$

In cases where travel motion takes place only for positioning the appliance and is not normally used for moving loads the effect of this motion shall not be combined with another horizontal motion. This is the case for example with a cocksie crane which, once it has been positioned, handles a series of loads at a fixed point.

2.3.2.

CASE II : APPLIANCE WORKING WITH WIND

The loads of case I are taken to which are added the effects of the limiting working wind S_W defined under 2.2.4.1.2.1. (table T.2.2.4.1.2.1.) and, where, applicable the load due to temperature variation, viz :

$$Y_C (S_G + \Psi S_L + S_H) + S_W$$

Note - The dynamic effects of acceleration and retardation do not have the same values in case II as in case I, for when a wind is blowing the accelerating or braking times are not the same as when still conditions prevail.

2.3.3.

CASE III : APPLIANCE SUBJECTED TO EXCEPTIONAL LOADINGS

Exceptional loadings occur in the following cases :

- appliance out of service with maximum wind
- appliance working and subjected to a buffer effect
- appliance undergoing the tests indicated in booklet 8.

The highest of the following combinations shall be considered :

- a) The loads S_G due to the dead weight, plus the load $S_{W \max}$ due to the maximum wind as mentioned under clause 2.2.4.1.2.2. (including the reactions of the anchorages)
- b) the loads S_G due to the dead weight and S_L due to the working load plus the greatest buffer effect S_T as envisaged in clause 2.2.3.4.
- c) the loads S_G due to the dead weight plus the highest of the two loads $\rho_1 S_L$ and $\rho_2 S_L$; ρ_1 and ρ_2 being the coefficients by which the safe working load is multiplied for the dynamic test (ρ_1) and for the static test (ρ_2) as in clauses 8.1.1. and 8.1.2.

These three cases are expressed by the formulae :

- a) $S_G + S_{Wmax}$
- b) $S_G + S_L + S_T$ (1)
- c) $S_G + \Psi \rho_1 S_L$ or $S_G + \rho_2 S_L$

Note 1 - It should be noted that the checks under (c) are only to be made in cases where the working load, when assumed to act alone, produces stresses opposed in direction to those caused by the dead weight up to the point at which the static test load does not exceed 1,5 times the safe working load.

Note 2 - When using decelerating devices in advance of buffer impact under the conditions mentioned in clause 2.2.3.4.1. S_T will be taken to be the highest load resulting either from the retardation previously caused by the decelerating device or from that finally caused by the buffer.

2.3.4.

CHOOSING THE AMPLIFYING COEFFICIENT γ_c

The value of the amplifying coefficient γ_c depends upon the group classification of the appliance.

Table T.2.3.4.

Values of amplifying coefficient γ_c

Appliance group	A1	A2	A3	A4	A5	A6	A7	A8
γ_c	1.00	1.02	1.05	1.08	1.11	1.14	1.17	1.20

2.4.

SEISMIC EFFECTS

In general the structures of lifting appliances do not have to be checked for European seismic effects.

However, if official regulations or particular specifications so prescribe, special rules or recommendations can be applied in areas subject to earthquakes.

This requirement shall be advised to the supplier by the user of the installation who shall also provide the corresponding seismic spectra.

- (1) Loadings resulting from the working load are taken into account but the effects of load swing resulting from the shock are neglected because this swing only loads the structure when the other effects have been practically absorbed. This comment does not apply to rigidly guided loads which cannot swing.

LOADS ENTERING INTO THE DESIGN OF MECHANISMS

Mechanisms are subjected to two kinds of loading :

- a) The loads, represented by the symbol S_M , which are directly dependent upon the torques exerted on the mechanisms by the motors or the brakes.
- b) The loads, represented by the symbol S_R , which are independent of motor or brake action but which are determined by the reactions which act upon the mechanical parts and which are not balanced by a torque acting on the drive shafts (1).

2.5.1.

TYPE S_M LOADS

The loads of this type to be considered are :

- a) S_{MG} loads, corresponding to a vertical displacement of the centre of gravity of moving parts of the appliance other than the working load.
- b) S_{ML} loads, corresponding to a vertical displacement of the working load as defined in clause 2.2. for structures.
- c) S_{MF} loads, corresponding to frictional forces which have not been allowed for in calculating the efficiency of the mechanism (see clause 4.2.6.1.1., booklet 4).
- d) S_{MA} loads, associated with acceleration (or braking) of the motion.
- e) S_{MW} loads, corresponding to the effect of the working wind assumed for the appliance.

2.5.2.

TYPE S_R LOADS

The loads of this type to be considered are :

- a) S_{RG} loads due to the weights of components which act on the part under consideration ;
- b) S_{RL} loads due to the working load as defined in clause 2.2., for structures.
- c) S_{RA} loads due to the accelerations or decelerations of the various motions of the appliance or its parts , as calculated according to clause 2.2.3.1. for structures, insofar as the order of magnitude of these loads is not negligible compared to the S_{RG} and S_{RL} loads.
- d) S_{RW} loads due to the limiting working wind S_W or to the maximum wind S_{Wmax} (see clause 2.2.4.1.), insofar as the order of magnitude of these loads is not negligible.

(1)

In a travel motion, for instance, the loads due to the vertical reaction on the rail wheels and the transverse loads that stress the wheel axle but are not transmitted to the components of the driving mechanism.

CASES OF LOADING

Three cases of loading are to be considered in the calculations :

Case I : Normal service without wind

Case II : Normal service with wind

Case III : Exceptional loadings.

A maximum load must be determined for each case of loading which serves as the basis for the calculations.

Note - Clearly, case I and II are one and the same in the case of appliances which are not exposed to wind.

The various loadings being determined as indicated in paragraph 2.5., account is taken of a certain probability of exceeding the calculated stress, which results from imperfect methods of calculation and unforeseen contingencies, by applying an amplifying coefficient γ_m depending on the group in which the mechanism is classified. The values of this coefficient γ_m are indicated in table T.2.6.

Table T.2.6.

Values of amplifying coefficient γ_m

Mechanism group	M1	M2	M3	M4	M5	M6	M7	M8
γ_m	1.00	1.04	1.08	1.12	1.16	1.20	1.25	1.30

2.6.1.

CASE I - NORMAL SERVICE WITHOUT WIND

2.6.1.1. TYPE S_M LOADS

The maximum load $S_{M \max I}$ of the S_M type (see clause 2.5.) is determined by combining the loads S_{MG} , S_{ML} , S_{MF} , and S_{MA} defined in clause 2.5.1. which can be expressed by the relation :

$$S_{M \max I} = (\bar{S}_{MG} + \bar{S}_{ML} + \bar{S}_{MF} + \bar{S}_{MA}) \gamma_m$$

Note - It must be pointed out that it is not the combination of the maximum values of each of the terms in this relation that must be considered, but the value resulting from the most unfavourable combination that could actually occur in practice.

2.6.1.2. TYPE S_R LOADS

The maximum load $S_{R \max I}$ of the S_R type (see clause 2.5.) is determined by combining the loads S_{RG} , S_{RL} , S_{RA} , defined in clause 2.5.2. which can be expressed by the relation :

$$S_{R \max I} = (\bar{S}_{RG} + \bar{S}_{RL} + \bar{S}_{RA}) \gamma_m$$

The note in clause 2.6.1.1. above applies here also.

2.6.2.

CASE II - NORMAL SERVICE WITH WIND

2.6.2.1. TYPE S_M LOADS

The maximum load $S_{M \max II}$ of the S_M type (see clause 2.5.) is determined by combining the loads S_{MG} , S_{ML} and S_{MF} defined in clause 2.5.1. with one of the following two combinations :

- a) the load S_{MA} and the load $S_{MW 8}$ corresponding to a 80 N/m² wind.
- b) the load $S_{MW 25}$ corresponding to a 250 N/m² wind.

The higher of the two values expressed by the relations set out below is taken :

$$S_{M \max II} = (\bar{S}_{MG} + \bar{S}_{ML} + \bar{S}_{MF} + \bar{S}_{MA} + \bar{S}_{MW 8}) Y_m$$

or

$$S_{M \max II} = (\bar{S}_{MG} + \bar{S}_{ML} + \bar{S}_{MF} + \bar{S}_{MW 25}) Y_m$$

The note in clause 2.6.1.1. applies here also.

2.6.2.2. TYPE S_R LOADS

The maximum load $S_{R \max II}$ of the S_R type (see clause 2.5.) is determined by combining the loads S_{RG} , S_{RL} and S_{RA} defined in clause 2.5.2. with $S_{RW 25}$ which corresponds to a 250 N/m² wind, as expressed by the relation :

$$S_{R \max II} = (\bar{S}_{RG} + \bar{S}_{RL} + \bar{S}_{RA} + \bar{S}_{RW 25}) Y_m$$

The note in clause 2.6.1.1. applies here also.

2.6.3.

CASE III - EXCEPTIONAL LOADS

2.6.3.1. TYPE S_M LOADS

The maximum load $S_{M \max III}$ of the S_M type defined under clause 2.5. is determined by considering the maximum load that the motor can actually transmit to the mechanism, allowing for limitations due to practical operating conditions.

The values of $S_{M \max III}$ are specified in clause 2.6.4.

2.6.3.2. TYPE S_R LOADS

Since the consequences of an overload due to collision with a buffer or fouling are far less serious for a mechanism than for the structure, the exceptional loading to be taken is that given under paragraph a) of clause 2.3.3. in the structures chapter.

This gives :
$$S_{R \max III} = \bar{S}_{RG} + \bar{S}_{RW \max}$$

In cases where additional mooring or guying means are used to ensure immobility or stability under maximum wind, the effect of these devices on the mechanism must be taken into account where applicable.

2.6.4. APPLICATION OF THE ABOVE CONSIDERATIONS FOR CALCULATING S_M

The mechanisms of hoisting appliances perform one of the following functions :

- Purely vertical displacements of the centre of gravity of moving masses (e.g. hoisting motions).
- Purely horizontal displacements in which the centre of gravity of the moving masses as a whole shifts horizontally (e.g. traverse, travel, slewing or counter-balanced luffing motions).
- Movements combining an elevation of the centre of gravity of the moving masses with a horizontal displacement (e.g. non-counterbalanced luffing).

2.6.4.1. HOISTING MOTIONS

For type S_M loads, the formula reduces to the following :

Case I and II :
$$S_{M \max I} = (\bar{S}_M + \bar{S}_{MF}) Y_m$$

In this case the load due to the hoisting acceleration is neglected because it is small compared to S_M .

Case III :
$$S_{M \max III} = 1,6 (\bar{S}_M + \bar{S}_{MF})$$

Bearing in mind the general rules of clause 2.6.3.1., it is assumed that the maximum loads that can be transmitted to hoisting mechanisms are limited in practice to 1,6 times the $S_{M \max I}$ load (1).

(1) In a hoisting motion it is impossible under normal working conditions to transmit to the mechanism loads greater than those due to the hoisting of the working load, as the effects of acceleration are negligible.

A greater load could result only from mishandling (poor judgement of the load, etc.).

On the basis of experience gained over many years of practice with widely differing hoisting appliances it is now accepted that a coefficient of 1,6 gives adequate safety. It must be stressed that the use of excessively powerful motors should be avoided.

2.6.4.2. HORIZONTAL MOTIONS

Case I - The formula reduces to :

$$S_{M \max I} = (\bar{S}_{MF} + \bar{S}_{MA}) Y_m$$

Case II - The higher of the following two values is taken :

$$S_{M \max II} = (\bar{S}_{MF} + \bar{S}_{MA} + \bar{S}_{MH 8}) Y_m$$

or

$$S_{M \max II} = (\bar{S}_{MF} + \bar{S}_{MH 25}) Y_m$$

Case III - For $S_{M \max III}$ the load corresponding to the maximum torque of the motor (or the brake) is taken unless operating conditions limit the torque actually transmitted, through wheel slip on the rails, or through the use of suitable limiting means (e.g. hydraulic coupling, torque limiter, etc.). In this case the value actually transmitted must be taken (1).

2.6.4.3. COMBINED MOTIONS

Case I and II :

For cases I and II, the load $S_{M \max II}$ (2) is determined by applying the general formula defined in clauses 2.6.1.1. and 2.6.2.1.

Case III :

The load caused by applying the maximum motor torque $S_{MC \max}$ can be taken for the maximum value $S_{M \max III}$. This often unduly high value is always acceptable since it enhances safety.

It must be used when the power involved for raising the centres of gravity of the moving masses is negligible compared to the power needed to overcome accelerations or wind effects.

Conversely, when the effect of the accelerations or the wind is negligible in comparison with the effect of displacing the centres of gravity of the moving masses vertically, this value is too high and $S_{M \max III}$ can be calculated from the formula :

$$S_{M \max III} = 1,6 S_{M \max II}$$

Between these two limiting values, each individual case should be examined according to the motor chosen, the method of starting and the relative magnitudes of the loads due to inertia and wind effects on the one hand and those due to raising of the centres of gravity on the other.

Without exception, when operating conditions limit the torque actually transmitted to the mechanism (see clause 2.6.4.2.), this limiting torque will be taken as the value of $S_{MC \max}$ if it is less than the values defined above.

- (1) whereas in the case of hoisting motions the loads normally transmitted to the mechanism are limited by the load lifted, in horizontal motions the maximum torque of the motor can always be transmitted to the mechanism if no mechanical limitation exists. This is why a different way of evaluating $S_{M \max III}$ has been specified according to whether a hoist motion or other motion is being considered.
- (2) or $S_{M \max I}$ in the case of appliances not subjected to wind.

APPENDIX A - 2.1.1.

HARMONISATION OF THE CLASSES OF UTILIZATION OF APPLIANCES AND MECHANISMS

The present appendix sets out to demonstrate a method by which it is possible in many cases to derive the class of utilization of mechanisms from that of appliances as a whole and from certain parameters characterizing the duty to be performed.

The starting point is the average duration t_{mc} (in seconds) of a hoisting cycle as defined in clause 2.1.2.2. This is therefore the time necessary to perform all the operations in such a cycle.

The total duration of use T of the appliance, expressed in hours, is then given by the relation :

$$T = \frac{N t_{mc}}{3600}$$

Where N represents the number of hoisting cycles determining the class of utilization of the appliance.

Table T.A.2.1.1.1. gives the values of T for cycle durations of 30 - 480 s in accordance with the class of utilization of the appliance. The number of hoisting cycles is the maximum number for this class of utilization ; these values are, however, adjusted to 15 625, 31 250 and 62 500 respectively for class U0, U1 and U2, in order to reduce the number of different values for T .

The next step is to determine for each mechanism the ratio α_i between the duration of use of the mechanism during a hoisting cycle and the average duration t_{mc} of the cycle.

Table T.A.2.1.1.2. gives the total durations of use T_i of the mechanism depending on the total duration of use of the appliance, and for various conventional values of the ratio α_i . This table also shows the class of utilization of the mechanism. The various classes are represented by the stepped areas.

It is thus sufficient to determine the class of utilization of the appliance by reference to table T.2.1.2.2., the average duration of the hoisting cycle and the values of α_i in order to obtain the classes of utilization of the mechanisms.

From the curves of the nomogram T.A.2.1.1.3. the classes of utilization for the mechanisms in terms of these three parameters can be found directly.

Table T.A.2.1.1.1.

Total duration of use (T) of lifting appliances in hours

Average duration of a hoisting cycle t_{mc} (s)	Class of utilization of appliance									
	U0	U1	U2	U3	U4	U5	U6	U7	U8	U9
30	130	260	520	1 040	2 085	4 165	8 335	16 665	33 335	> 33 335
45	195	390	780	1 565	3 125	6 250	12 500	25 000	50 000	> 50 000
60	260	520	1 040	2 085	4 165	8 335	16 665	33 335	66 665	> 66 665
75	325	650	1 300	2 605	5 210	10 415	20 835	41 665	83 335	> 83 335
90	390	780	1 565	3 125	6 250	12 500	25 000	50 000	100 000	> 100 000
120	520	1 040	2 085	4 165	8 335	16 665	33 335	66 665	133 335	> 133 335
150	650	1 300	2 605	5 210	10 415	20 835	41 665	83 335	166 665	> 166 665
180	780	1 565	3 125	6 250	12 500	25 000	50 000	100 000	200 000	> 200 000
240	1 040	2 085	4 165	8 335	16 665	33 335	66 665	133 335	> 200 000	
300	1 300	2 605	5 210	10 415	20 835	41 665	83 335	166 665	> 200 000	
360	1 565	3 125	6 250	12 500	25 000	50 000	100 000	200 000	> 200 000	
420	1 825	3 645	7 290	14 585	29 165	58 335	116 665	> 200 000		
480	2 085	4 165	8 335	16 665	33 335	66 665	133 335	> 200 000		

Table T.A.2.1.1.2.

Total duration of use T_i (in hours) of mechanisms in terms of T and α_i :

T (h)	Values of α_i						Class of utilization for mechanism
	1,00	0,63	0,40	0,25	0,16	0,10	
130	130	82	52	33	21	13	T0
195	195	123	78	49	31	20	
260	260	164	104	65	42	26	
325	325	205	130	81	52	33	
390	390	246	156	98	62	39	
520	520	328	208	130	83	52	
650	650	410	260	163	104	65	
780	780	491	312	195	125	78	
1 040	1 040	655	416	260	166	104	
1 300	1 300	819	520	325	208	130	
1 565	1 565	986	626	391	250	157	
1 825	1 825	1 150	730	456	292	183	
2 085	2 085	1 314	834	521	334	209	
2 605	2 605	1 641	1 042	651	417	261	
3 125	3 125	1 969	1 250	781	500	313	
3 645	3 645	2 296	1 458	911	583	365	
4 165	4 165	2 624	1 666	1 041	666	417	
5 210	5 210	3 282	2 084	1 303	834	521	
6 250	6 250	3 938	2 500	1 563	1 000	625	
7 290	7 290	4 593	2 916	1 823	1 166	729	
8 335	8 335	5 251	3 334	2 084	1 334	834	
10 415	10 415	6 561	4 166	2 604	1 666	1 042	
12 500	12 500	7 875	5 000	3 125	2 000	1 250	
14 585	14 585	9 189	5 834	3 646	2 334	1 459	
16 665	16 665	10 499	6 666	4 166	2 666	1 667	
20 835	20 835	13 126	8 334	5 209	3 334	2 084	
25 000	25 000	15 750	10 000	6 250	4 000	2 500	
29 165	29 165	18 374	11 666	7 291	4 666	2 917	
33 335	33 335	21 001	13 334	8 334	5 334	3 334	
41 665	41 665	26 249	16 666	10 416	6 666	4 167	
50 000	50 000	31 500	20 000	12 500	8 000	5 000	
58 335	58 335	36 751	23 334	14 584	9 334	5 834	
66 665	66 665	41 999	26 666	16 666	10 666	6 667	
83 335	83 335	52 501	33 334	20 834	13 334	8 334	
100 000	100 000	63 000	40 000	25 000	16 000	10 000	
116 665	116 665	73 499	46 666	29 166	18 666	11 667	
133 335	133 335	84 001	53 334	33 334	21 334	13 334	
166 665	166 665	104 999	66 666	41 666	26 666	16 667	
200 000	200 000	126 000	80 000	50 000	32 000	20 000	
> 200 000	> 200 000	> 126 000	> 80 000	> 50 000	> 32 000	> 20 000	
							T8
							T9

Table T.A.2.1.1.3.

Classes of utilization for appliances and mechanisms

Class of utilization for appliances

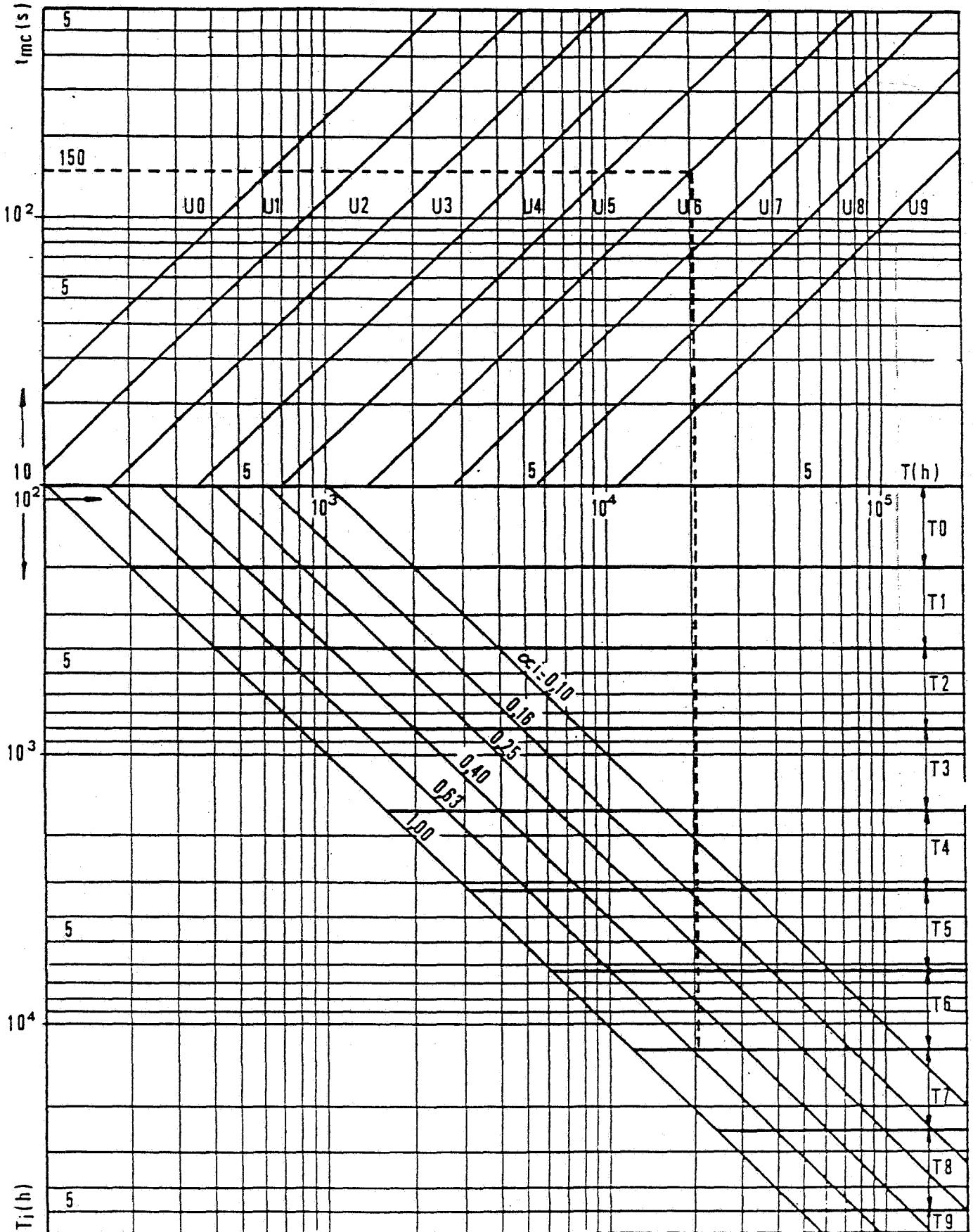

EXAMPLE OF APPLICATION

Dockside cargo crane.

The class of utilization for the appliance will be U5.

A hoisting cycle comprises the following operations :

- hoisting of load ;
- travelling ;
- slewing ;
- lowering ;
- unhooking of load ;
- hoisting empty ;
- slewing ;
- travelling ;
- lowering empty ;
- hooking on of new load.

The average time for completion of the cycle will be estimated at 150 s.

The ratios α_i will be estimated as follows :

- hoisting (hoisting and lowering) : $\alpha_i = 0.63$
- slewing (2 directions) : $\alpha_i = 0.25$
- travelling (do.) : $\alpha_i = 0.10$

Table T.A.2.1.1.1. gives us for class U5 and $t_{mc} = 150$ s :

$$T = 20\ 835\ h$$

For the various mechanisms, table T.A.2.1.1.2. gives us, for $T = 20\ 835$ h, the following total durations T_i and classes of utilization :

- | | | | |
|--------------|-----------------------|---------------------|----|
| - hoisting | ($\alpha_i = 0.63$) | : $T_i = 13\ 126$ h | T7 |
| - slewing | ($\alpha_i = 0.25$) | : $T_i = 5\ 209$ h | T5 |
| - travelling | ($\alpha_i = 0.10$) | : $T_i = 2\ 084$ h | T4 |

From the curves in table T.A.2.1.1.3. the same conclusions are drawn on the basis of the ordinate $t_{mc} = 150$ s (broken line).

APPENDIX A - 2.2.3.

CALCULATION OF LOADS DUE TO ACCELERATIONS OF HORIZONTAL MOTIONS

PART 1 - METHOD

1. BASIC DATA

Let

- v be the steady horizontal velocity of the point of suspension of the load, either at the end of the acceleration period, or at the beginning of the braking period, according to whether an acceleration or a braking process is being considered, and
- F an imaginary horizontal force in the same direction as v, applied at the point of suspension of the load and producing the same effect on the motion under consideration as the accelerating or decelerating torque applied by the motor or the brake.

2. PROCEDURE

The different quantities set out below must be calculated in succession.

Equivalent mass (m)

The inertia of all moving parts other than the load, in the motion under consideration, is replaced by a single equivalent mass m assumed to be concentrated at the point of suspension of the load and given by the relation :

$$m = m_0 + \sum_i \frac{I_i \cdot w_i^2}{v^2}$$

where :

- m_0 = is the total mass of all elements, other than the load, undergoing the same pure linear motion as the point of suspension of the load ;
- I_i = the moment of inertia of a part undergoing a rotation during the motion under consideration, this moment of inertia being considered about the axis of rotation, and
- w_i = the angular velocity of the part referred to, about its axis of rotation, corresponding to the linear velocity v of the point of suspension of the load.

The sum Σ covers all parts in rotation (structure, mechanisms, motor) during the motion considered. However, in the case of mechanisms, the inertia of components other than those directly coupled to the motor shaft can be ignored.

Mean acceleration or deceleration (j_m) :

$$j_m = \frac{F}{m + m_1}$$

where m_1 is the mass of the load.

Mean duration of acceleration or deceleration (T_m) :

$$T_m = \frac{v}{j_m}$$

Mean inertia forces :

The acceleration corresponding to the acceleration j_m at the point of suspension of the load is calculated for each component part in motion. Multiplying this acceleration by the mass of the component considered gives the mean inertia force it sustains.

In the particular case of the load itself, this force of inertia F_{cm} will be given by :

$$F_{cm} = m_1 j_m$$

Period of oscillation T_1 : $T_1 = 2 \pi \sqrt{\frac{\ell}{g}}$

ℓ = the length of suspension of the load when it is in its uppermost position (values of ℓ below 2,00 m need not be taken into consideration) and,

g = the acceleration due to gravity.

Value of μ :

$$\mu = \frac{m_1}{m}$$

When the system driving the motion controls the acceleration and the deceleration and maintains it at a constant value, μ is taken equal to 0 irrespective of the masses m and m_1 .

Value of β :

$$\beta = \frac{T_m}{T_1}$$

Value of Ψ_h :

With the values obtained for μ and β , the graph in figure A.2.2.1. is used to find the corresponding value of Ψ_h .

Inertia forces to be considered in the design of the structure :

The forces of inertia which take account of dynamic effects and which must therefore be considered in the structural calculations are obtained as follows :

- Inertia force due to the load : $\Psi_h \cdot F_{cm}$
- Inertia force on moving parts other than the load : twice the mean inertia forces.

3.

JUSTIFICATION

A justification of the method given above follows in part 2 of this appendix.

PART 2 — EXPLANATION OF THE METHOD

1. STATEMENT OF THE PROBLEM

A hoisting appliance is a physical system consisting essentially of :

- concentrated masses (hook load, counterweights, ...) and distributed masses (girders, ropes, ...),
- elastic connections between these masses (girders, ropes, ...).

If such a system, originally in a state of equilibrium, is subjected to a varying load, it does not tend progressively towards a new state of equilibrium even if the new load applied is itself constant. On the contrary, it is set in a more or less complex oscillating motion about this new state of equilibrium. During this motion, the various internal loads and stresses of the system can exceed - sometimes to a marked extent - the values they would have assumed had the system been in static equilibrium under the influence of the new load.

Such a situation arises during acceleration or deceleration (braking) of a horizontal motion of a hoisting appliance. Thus if, starting from a position of rest, an appliance or part of an appliance begins a motion of translation or rotation, the component parts of the system undergo accelerations and are therefore subjected to inertia forces. Once a steady speed is attained, the acceleration ceases, the inertia forces disappear and the external load undergoes a new variation.

The angle through which a rotating system turns (e.g. the rotating part of a crane) during the time for which inertia forces are applied is generally relatively small. This being so, no appreciable error will be involved if one assumes that each point in the system follows a straight path during this time. Since, moreover, there is no difference of principle between the treatment used for linear motions and motions of rotation, in what follows the linear motion will be considered in greater detail (chapter 2), whereas only a short note (chapter 3) will cover rotation.

2. CALCULATING THE LOADS IN THE CASE OF A LINEAR MOTION

2.1. GENERAL DATA

It is now proposed to examine the particular case of braking of the travel motion of a complete overhead travelling crane when it is carrying a load suspended from its hoisting rope. Other cases encountered in practice can be dealt with in similar fashion.

Considering figure A.2.1. let :

- m_1 be the mass of the suspended load,
- m the total mass of the overhead travelling crane including the crab (see note below concerning the inertia of the motor and of the machinery driving the motion),
- x a coordinate defining the position of the crane along its track (more precisely, x represents the coordinate of the point of suspension of the hoisting rope along an axis parallel to the direction of travel),

x_1 - a coordinate defining the position of the centre of gravity of the suspended load along an axis of the same direction, sense and origin as the axis of x ,

$z = x_1 - x$ a coordinate expressing the horizontal displacement of the load relative to the crane.

Let us assume that at the instant $t = 0$ the overhead travelling crane is moving in the positive sense of the x axis at a velocity v , and that the load is at rest relative to the crane.

$$(z = z' = 0, \text{ with } : z' = \frac{dz}{dt})$$

If the brake is applied to the travel mechanism at the instant $t = 0$, it will give rise from that instant to a horizontal braking force parallel to, but of opposite sense to, the x axis at each point where a driving wheel is in contact with its rail. To simplify matters, let us assume that the crab is located at mid-span of the main girders of the overhead travelling crane. It follows by symmetry that the total force at each rail is the same. Let us designate its projection on the x axis by $\frac{F}{2}$ (with $F > 0$), so that the total braking force acting on the system in motion $\frac{F}{2}$ (crane plus load) is equal to F in absolute value.

If the system were composed of rigidly interconnected masses, this would result in a deceleration of absolute value j_m , given by the relation :

$$j_m = \frac{F}{m + m_1} \quad (2.1.1.)$$

Figure A.2.1.

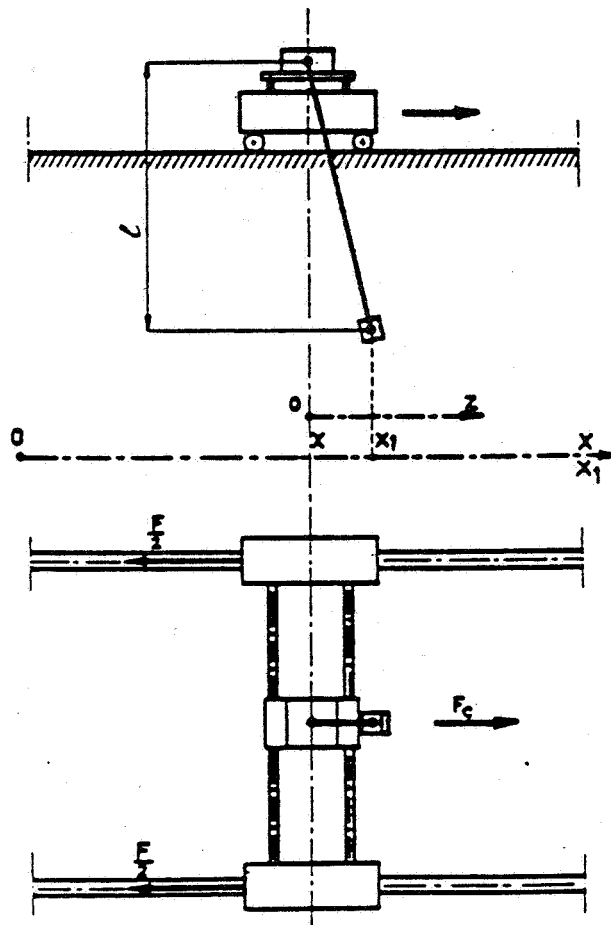

It must not be forgotten however that F originates in the braking torque applied to the travel mechanism which must not only brake the travel inertia of the crane and the load but also the rotational inertia of the driving motor and the intervening machinery. Generally speaking, one can neglect the rotating inertia of all components other than those integral with the motor shaft. In many cases, however, the inertia of the latter must be taken into account and the relation (2.1.1.) holds good only provided that m incorporates an equivalent mass m_e given by the relation :

$$m_e v^2 = I_m \omega_m^2 \quad (2.1.2.)$$

where

I_m = is the moment of inertia of all the components integral with the motor shaft (including the motor itself, of course) and

ω_m = the angular velocity of the motor corresponding to the travelling speed v of the crane.

Under the effect of the deceleration j_m , the suspension rope cannot retain its vertical position. Its new position of equilibrium is inclined to the vertical at an angle α_m given by the relation :

$$\alpha_m = \text{arctg} \frac{j_m}{g} \quad (2.1.3.)$$

where g is the acceleration due to gravity. In this case the rope exerts a horizontal force on the crane whose projection F_{cm} on the x axis is given by :

$$F_{cm} = m_1 j_m \quad (2.1.4.)$$

In point of fact, the system is not rigid, the deceleration is not constant and is not therefore given by (2.1.1.), the load and its suspension rope adopt an oscillating motion, and the horizontal force developed by the rope on the crane can assume values differing greatly from (2.1.4.).

By a similar reasoning, one may conclude that the deceleration of the system gives rise to inertia forces which act on each component part of the crane and the crab, but that because of the elasticity of the girders the system will undergo an oscillating motion in the course of which the stresses will be subject to fluctuations which must be estimated.

The next two paragraphs deal in succession with the effect of the inertia forces on the load and on the girders.

2.2. EFFECT OF INERTIA FORCES ON THE LOAD

In determining the motion which the load executes after the brake is applied, one can neglect the movement of the point of suspension due to girder flexibility in a horizontal plane. The amplitude of this movement is, in fact, very small compared with the amplitude of swinging of the load. Calculations can therefore be carried out with the crane considered as a system which is not subject to deformation.

The projection F_c on the x axis of the force exerted by the rope on the crane is given by the relation :

$$F_c = m_1 g \frac{x_1 - x}{\ell} = m_1 g \frac{z}{\ell} \quad (2.2.1.)$$

where ℓ is the suspension length of the load. It will be noted that F_c is proportional to the displacement z of the load with respect to its position of initial equilibrium, just as if it were an elastic restoring force.

The equations of motion can be written :

$$m_1 x''_1 = m_1 g \frac{x_1 - x}{\ell} \quad (2.2.2.)$$

$$m x'' = m_1 g \frac{x_1 - x}{\ell} - F \quad (2.2.3.)$$

while, assuming $x = 0$, for $t = 0$, the initial conditions are as follows :

$$\text{for } t = 0, \quad x_1 = x = 0 \quad (2.2.4.)$$

$$x'_1 = x' = v \quad (2.2.5.)$$

$$z = x_1 - x = 0 \quad (2.2.6.)$$

$$z' = x'_1 - x' = 0 \quad (2.2.7.)$$

Let :

$$\frac{g}{\ell} = \omega_1^2 \quad (2.2.8.)$$

$$\frac{m_1}{m} \cdot \frac{g}{\ell} = \omega_2^2 \quad (2.2.9.)$$

$$\omega_1^2 + \omega_2^2 = \omega_T^2 \quad (2.2.10.)$$

$$\frac{F}{m} = j_0 \quad (2.2.11.)$$

Equations (2.2.2.) and (2.2.3.) then become :

$$x'' + z'' + \omega_1^2 z = 0 \quad (2.2.12.)$$

$$x'' - \omega_2^2 z = -j_0 \quad (2.2.13.)$$

whence

$$z'' + \omega_T^2 z = j_0 \quad (2.2.14.)$$

With the initial conditions of (2.2.4.) to (2.2.7.), the solution to these equations is given by :

$$z = \frac{j_0}{\omega_T^2} (1 - \cos \omega_T t) \quad (2.2.15.)$$

$$x' = v - \frac{\omega_1^2}{\omega_T^2} j_0 t - \frac{\omega_2^2}{\omega_T^2} \cdot \frac{j_0}{\omega_T} \sin \omega_T t \quad (2.2.16.)$$

The complete expression for x is of no direct interest to us.

Let :

$$\frac{j_0}{\omega_T^2} = z_m \quad (2.2.17.)$$

it can then be seen without difficulty that z_m is the position of equilibrium that can be assumed by the load during a constant deceleration of the crane equal to the value j_m defined by (2.1.1.), i.e. during the deceleration that would be obtained by applying the braking force F to the total mass (crane plus load) in motion, this mass being assumed to constitute a rigid system. The value $z = z_m$ defining the load displacement corresponds to the horizontal force F_{cm} , defined by (2.1.4.) exerted by the rope on the crane. Comparison between (2.2.1.), (2.2.15.) and (2.2.17.) then shows that :

$$F_c = F_{cm} (1 - \cos \omega_T t) \quad (2.2.18.)$$

If the deceleration period of the crane lasts for a time t_d such that :

$$\omega_T t_d \geq \pi \quad (2.2.19.)$$

it will be seen that F_c momentarily becomes twice F_{cm} , or in other words, that its maximum value $F_{c \max}$ is given by the relation :

$$F_{c \max} = 2 F_{cm} \quad (2.2.20.)$$

If the condition (2.2.19.) is not satisfied, this means that the crane has stopped before the load has reached its maximum displacement $z = 2 z_m$. However, after the crane stops, the load will usually continue to oscillate, so the rope will continue to exert a varying horizontal force on the crane, and the maximum value which this can attain must be sought.

It is easy to verify that after the crane has stopped, the motion of the load is defined by the expression :

$$z = z_d \cos \omega_1 (t - t_d) + \frac{z'_d}{\omega_1} \sin \omega_1 (t - t_d) \quad (2.2.21.)$$

with

$$z_d = z_m (1 - \cos \omega_T t_d) \quad (2.2.22.)$$

$$z'_d = \omega_T z_m \sin \omega_T t_d \quad (2.2.23.)$$

where t_d is the smallest positive value of t that makes the expression (2.2.16.) for x' equal to zero.

The maximum value $F_{c \max}$ assumed by F_c is then given by the relation :

$$F_{c \max} = F_{cm} \sqrt{(1 - \cos \omega_T t_d)^2 + \frac{\omega_T^2}{\omega_1^2} \sin^2 \omega_T t_d} \quad (2.2.24.)$$

Generally speaking, we may take :

$$\frac{F_{c \max}}{F_{cm}} = \Psi_h \quad (2.2.25.)$$

The determination of Ψ_h is simplified by introducing the following quantities :

$T_m = \frac{v}{J_m}$ the time for which the slowing-down phase of the crane would last if the deceleration were constant and the system in motion not subject to deformation.

$T_1 = \frac{2 \pi}{\omega_1}$ the period of oscillation of the pendulum system formed by the suspended load (crane stopped).

$$T_1 = 2 \pi \sqrt{\frac{l}{g}}$$

It can be verified without difficulty that Ψ_h depends only on two non-dimensional parameters μ and β defined by the ratios :

$$\mu = \frac{m_1}{m} \quad (2.2.26.)$$

$$\beta = \frac{T_m}{T_1} \quad (2.2.27.)$$

which can be obtained very easily. It will be noted that (2.2.16.) can be written :

$$x' = v \left[1 - \frac{(\omega_T t) + \mu \sin (\omega_T t)}{2 \pi \beta \sqrt{1 + \mu}} \right] \quad (2.2.28.)$$

and therefore :

$$\frac{(\omega_T t_d) + \mu \sin (\omega_T t_d)}{2 \mu \beta \sqrt{1 + \mu}} = 1 \quad (2.2.29.)$$

this equation makes it possible to determine the value of $\omega_T t_d$ to be introduced into (2.2.24.).

The graph in figure (2.2.1.) plots the values of Ψ_h against β for various values of μ . (The curve $\mu = 0$ will be explained later in Chapter 5).

If $\mu < 1$ (which is generally the case with overhead travelling crane travel motions, such as that in the example dealt with), an analysis of the problem shows that Ψ_h can in no case exceed 2. This value is reached during the crane deceleration phase if the condition (2.2.19.) is satisfied or, which is the same thing, if β reaches or exceeds a certain critical value, β_{crit} dependent upon μ . Above this critical value, Ψ_h therefore remains constant and equal to 2, whatever the value of β .

If $\mu > 1$ (which could be the case with traverse motions, in which m essentially represents only the mass of the crab, or with slewing motions), the same analysis shows that, again provided β reaches or exceeds a certain critical value β_{crit} dependent upon μ , Ψ_h can exceed 2 and reach a maximum given by :

$$\Psi_h = \sqrt{2 + \mu + \frac{1}{\mu}} \quad (2.2.30.)$$

This maximum can actually be reached only during the swinging motion of the load subsequent to the bringing to rest of its point of suspension. The critical value β_{crit} is such that the crane is halted before the condition (2.2.19.) is satisfied, or before F_c reaches $2 F_{cm}$. However, any value of β greater than β_{crit} leads to the condition (2.2.19.) being satisfied and F_c necessarily passes the value $2 F_{cm}$, whence $\Psi_h > 2$. It will also be noted that if $\beta > \beta_{crit}$ has been calculated taking v equal to the maximum steady speed of the motion, braking applied starting from the initial speed :

$$\frac{\beta_{crit} v}{\beta}$$

will necessarily lead to the maximum value of Ψ_h given by (2.2.30.). This is the reason why, in the graph of figure A.2.2.1., the values of Ψ_h have been maintained for all values of β greater than β_{crit} .

Figure A.2.2.1.

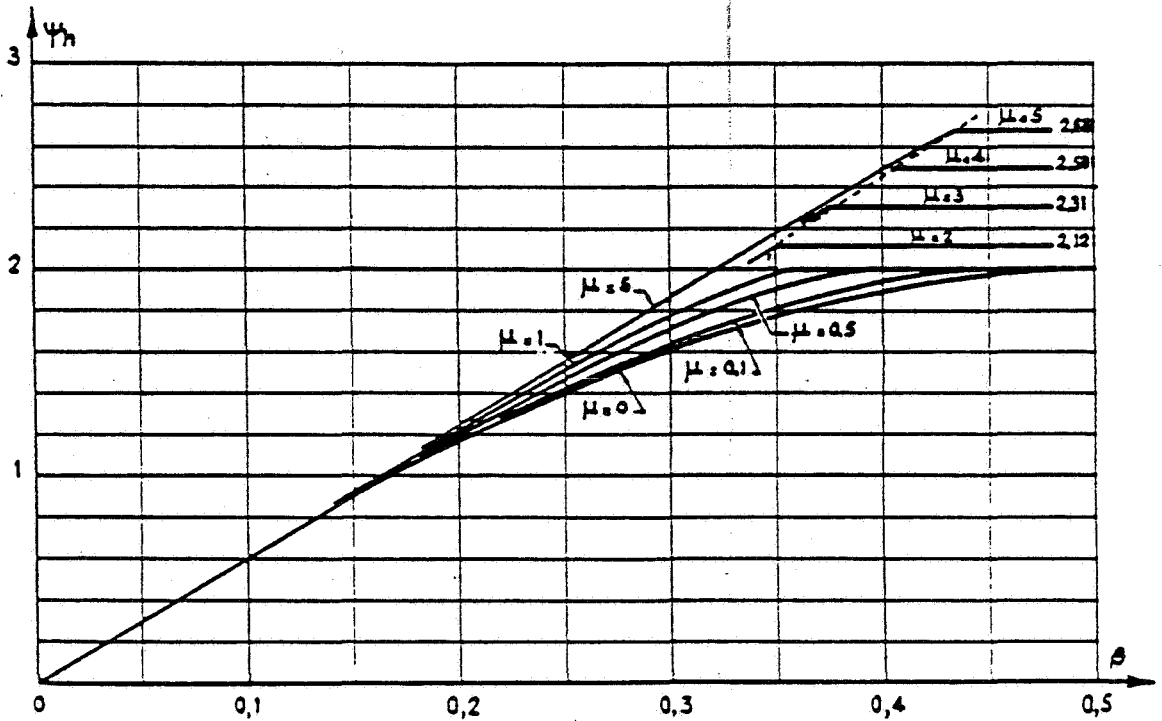

As regards the choice of T_1 , it should be noted that the danger of reaching high values of Ψ_h is all the greater as the suspension length ℓ of the load becomes shorter, because β then attains its critical value more rapidly. The calculations must therefore be made assuming that the load is near its uppermost position. In practice ℓ will generally lie between 2 and 8 m. The table below gives the values of T_1 for a few values of ℓ .

ℓ (m)	T_1 (s)
2	2,84
3	3,47
4	4,01
5	4,49
6	4,91
7	5,31
8	5,67

It remains for us to examine the effect of the horizontal force $F_{C \max}$ on the loading conditions sustained by the structure.

This force actually exists, so that any components such as the crab which transmit it directly must be designed to withstand it. The configuration of the load acting on the girder as a whole therefore deserves some attention.

Let us first consider the case where $F_{C \max}$ occurs before the crane has come to halt. It would be incorrect to consider the latter as a beam supported at both ends and subjected at its centre to the force $F_{C \max}$. One must not lose sight of the fact that each of the two supporting points can transmit only a reaction $\frac{F}{2}$. The successive diagrams in figure A.2.2.2. illustrate how the problem must be considered. Diagram "a" represents the ideal state of equilibrium, in which the system as a whole is subjected to a deceleration j_m (or an acceleration $x'' = -j_m$) and in which the rope develops a force F_{Cm} . Each material element dm of the system therefore sustains an inertia force $j_m dm$. Diagram "a" is a superimposition of diagram "b" and diagram "c". Diagram "b" relates to the load due to the inertia forces on the crane proper (this is dealt with in paragraph 2.3.), while diagram "c" shows the effect of the load due to the rope. In point of fact, the actual force developed by the rope is not the force F_{Cm} represented in diagram "c" but the force :

$$F_{C \max} = \Psi_h F_{Cm} \quad (2.2.31.)$$

Since the supporting points (braked wheels) are not capable of increasing their reaction, the excess force $(\Psi_h - 1)F_{Cm}$ can only result in a supplementary acceleration x'' expressed by :

$$x'' = (\Psi_h - 1) \frac{F_{Cm}}{m} \quad (2.2.32.)$$

which is translated into a distributed load $-x'' dm$ on all material elements of the crane. Diagram "d" consequently represents the loading configuration to be taken into account when designing the girders.

Let us consider the case in which $F_{C \max}$ arises after the crane has halted. This time, the braked wheels no longer have to devote part of the reaction of which they are capable to taking up the inertia forces on the crane, and in general,

must be regarded as being fixed. This being so, the girder must be designed as if it were supported at each end and subjected to the force F_{cm} at its centre. This latter case is in point of fact the only one which needs to be considered, because when F_c reaches its maximum value $2 F_{cm}$ before the crane comes to a standstill this force can still arise in the course of the pendulum motion which follows after it has stopped.

All the preceding considerations still hold good if, instead of considering a braking phase, one is dealing with an acceleration phase of the crane, in the course of which it is speeded up, by a constant driving torque, from rest to a given steady speed.

2.3. EFFECT OF INERTIA FORCES ON THE STRUCTURAL STEELWORK

In the previous chapter, the structure was assumed to be perfectly rigid. In fact, however, it possesses a degree of elasticity and consequently also assumes an oscillating motion during the braking period and after coming to rest. Because the structure is composed essentially of distributed rather than simple concentrated masses, it is usually very difficult to determine the motion theoretically, and such calculations would be justified only in the case of very large appliances in which the inertia forces play an appreciable part.

Figure A.2.2.2.

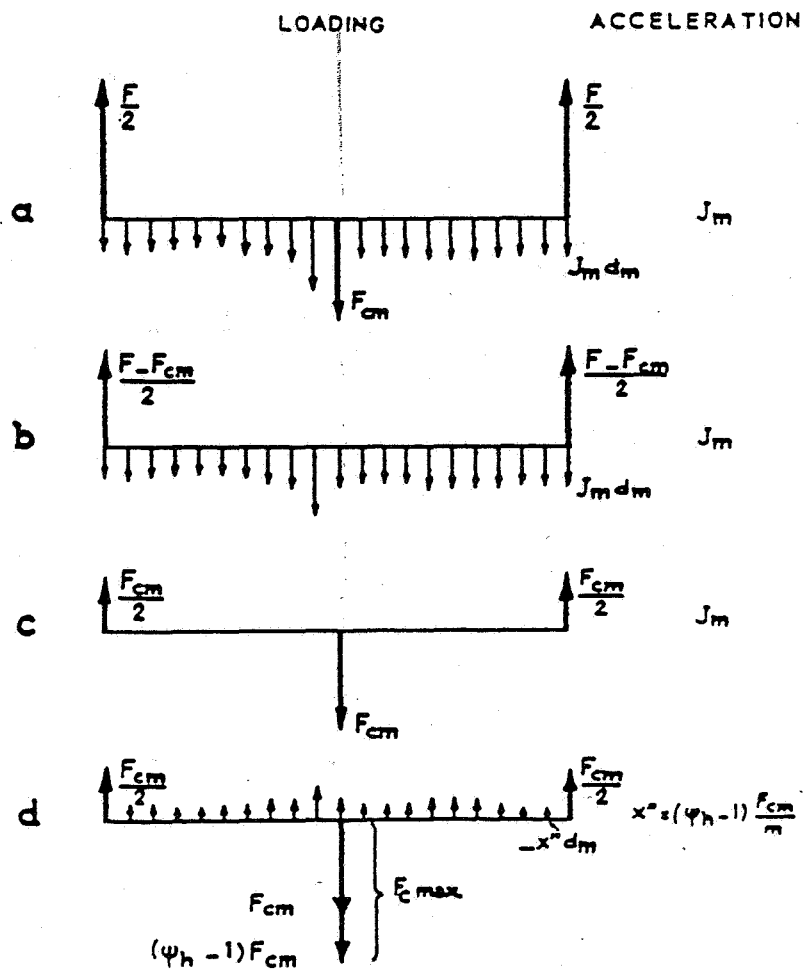

In almost all cases, it will suffice to represent a structure as being a simple oscillating system having restoring forces proportional to the extension and subjected to the overall acceleration of the reference system to which it is referred. In view of the note following expression (2.2.1.) the considerations developed in paragraph 2.2. can be applied here also. However, the natural period of the oscillations (comparable to the period T_1 of paragraph 2.2.) is always appreciably shorter than that of a suspended load, not exceeding a few tenths of a second in most cases. The result of this is that the parameter corresponding to β always exceeds the critical value β_{crit} , so that ψ_h must always be taken equal to 2, this being the coefficient applicable to inertia loads calculated with the mean deceleration j_m . The only exception that could be made to this rule would be for extremely brief retardation phases, such as those resulting from braking a low-speed travel motion, with the wheels slipping on the rails.

Because the oscillating motions of the structure have a high frequency, the maximum resulting loadings are superimposed momentarily upon those due to the load.

3. CALCULATING THE LOADS IN THE CASE OF A SLEWING MOTION

In the case of a slewing motion, considerations similar to those of chapter 2 can be developed. To calculate the effects of the inertia forces on the load, it is only necessary to determine m from the relation :

$$m v^2 = I \omega^2 \quad (3.1.)$$

where

v is the horizontal linear velocity of the suspension point of the load ;

I is the moment of inertia of all parts in motion (structure, machinery, motor) referred to a particular shaft,

ω is the angular velocity of that shaft corresponding to the velocity v above.

4. CALCULATING THE LOADS IN THE CASE OF A LUFFING MOTION

In the case of a luffing motion, considerations similar to those of chapter 2 can be developed. It will suffice to determine m from the relation :

$$m v^2 = 2 T \quad (4.1.)$$

where

v is the horizontal linear velocity of the suspension point of the load.

T is the total kinetic energy of the masses in motion when the horizontal linear velocity of the suspension point of the load is equal to v .

5.

SYSTEMS WITH REGULATED ACCELERATION

In some control systems, such as certain Ward-Leonard or hydraulically actuated systems, the magnitudes of the accelerations and decelerations are dictated by the characteristics of the system and are maintained constant regardless of external conditions. For this reason, load swing does not disturb the acceleration or deceleration conditions of the appliance or part of the appliance in motion.

In the example dealt with in paragraph 2.2., this would be tantamount to assuming that x'' is a given constant. Using equation (2.2.12.) and its derivations, it is easy to show that in this case :

$$\Psi_h = 2 \sin \beta \pi \text{ for } \beta \leq 0,5 \quad (5.1.)$$

$$= 2 \quad \text{for } \beta > 0,5 \quad (5.1.)$$

Such a situation would also obtain if one assumed the mass m_1 to be infinitely small compared with m and therefore unable to disturb its motion. This being so, (5.1.) is the limiting curve obtained by making μ tend to zero, and is represented on diagram 2.2.1. by the curve $\mu = 0$.

The considerations in paragraph 2.3. are in no way modified.

6.

GENERAL CONCLUSIONS

Knowing the torque or the braking or accelerating force, the first step is to calculate the mean deceleration or acceleration j_m , obtained on the assumption that the various parts of the structure are perfectly rigid and the load is concentrated at its point of suspension. Using this acceleration, one calculates the inertia forces acting on both the load and the various elements of the structure. These forces are then multiplied by a certain coefficient Ψ_h in order to take account of the elasticity of the various connections.

For the inertia forces acting on the structure Ψ_h is always taken equal to 2, except possibly in the special case mentioned in the penultimate paragraph of 2.3., provided justification can be provided for the reduction.

In the case of the inertia forces acting on the load, the mass m is calculated (incorporating, where necessary, the mass equivalent to the inertia of the rotor and the mechanism) and the mean deceleration or acceleration time T_1 is then determined on the basis of the maximum steady speed of the motion. The value of T_1 depends on the suspension length of the load in its uppermost position, and is therefore known. Hence one can determine the parameters μ and β ($\beta = 0$ in the case of a regulated-acceleration system), and figure A.2.2.1. furnishes the corresponding value of Ψ_h . In almost all cases, the maximum force appears or can appear after completion of the braking or starting phase under consideration. Its effects on the structure can be ascertained by applying the ordinary laws of statics.

It will be noted that the calculations developed in Chapter 2 assume the load to be relatively at rest ($z = z' = 0$) at the initial time $t = 0$. If this is not so, the motion of the system is affected and Ψ_h can reach values considerably higher than those we have fixed. Such a situation could arise for instance when a motion is braked by repeated intermittent applications of the brake, or when successive motions take place at fairly short intervals. The method of calculation indicated above is therefore not excessive in any way, and special cases exist in which it would be well to exercise some caution in applying it.

Etabli par la Section I
Prepared by Section I
Erstellt durch die Sektion I

- APPAREILS LOURDS DE LEVAGE ET DE MANUTENTION
- HEAVY LIFTING EQUIPMENT
- KRANE UND SCHWERE HEBEZEUGE

FEDERATION EUROPEENNE DE LA
MANUTENTION
(FEM)

Secrétariat : Secrétariat de la FEM Section I
Secretariat : c/o Syndicat National des Industries d'Equipement M.T.P.S.
Sekretariat : 10, Avenue Hoche
75382 PARIS CEDEX 08
Tél. : (33 1) 45 63 02 00 - Poste 3304 - Télex : 280 900

En vente auprès du secrétariat ou des comités nationaux de la F.E.M. suivants :
Available from the above secretariat or from the following national committees of the FEM :
Zu beziehen durch das oben angegebene Sekretariat oder durch die folgenden Nationalkomitees der FEM :

BELGIQUE

Comité National Belge de la FEM
Fabrimétal
Rue des Drapiers, 21
B - 1050 BRUXELLES
Tél. : (32 2) 510 23 11 - Télex : 21078

DEUTSCHLAND

Deutsches Nationalkomitee der FEM
V.D.M.A.
Lyoner Strasse 18
Postfach 71 08 84
O - 6000 FRANKFURT/MAIN 71
Tél. : (46 69) 66 030 - Télex : 411 321 oder 413 152

ESPAÑA

Comité Nacional Español de la FEM
Asociación Nacional de Ingenieros Industriales
Via Layetana, 39 (bajos)
E - 08003 BARCELONA
Tél. : (34 3) 319 73 30 - Télex : 51228 COIN-E
(att. CNE-FEM)

FRANCE

Comité National Français de la FEM
pour la Section I
Syndicat National des Industries d'Equipement MTPS
10, Avenue Hoche
F - 75382 PARIS CEDEX 08
Tél. : (33 1) 45.63.02.00 - Télex : 280 900

GREAT BRITAIN

British National Committee of FEM for Section I
F.M.C.E.C.
Carolyn House
22-26 Dingwall Road
GB - CROYDON CR9 2PL
Tél. : (01) 588 44 22 - Télex : 941 36 25

ITALIA

Comitato Nazionale Italiano della FEM
Associazione Nazionale Industria Meccanica Varia
ed Affine (ANIMA)
Piazza Diaz 2
I - 20123 MILANO
Tél. : (392) 80 90 06 - Télex : 310 392

LUXEMBOURG

Comité National Luxembourgeois de la FEM
Groupement des Constructeurs et Fondateurs
du Grand-Duché de Luxembourg
Rue Alcide de Gasperi 7 /B.P. 1304
L - LUXEMBOURG - KIRCHBERG
Tél. : (352) 435 355/7/8

NEDERLAND

Nederlands Nationaal Comité bij de FEM
FME/GKT
Gredewater 33
Postbus 193
NL - 2700 AD ZOETERMEER
Tél. : (31 79) 531 268 - Télex : 32157

NORGE

Norwegian FEM Groups
Norsk Verkstedsindustri Standardiseringsentral NVS
Oscars gate 20
P.O. BOX 7072 H
N - 0306 OSLO 3
Tél. : (472) 46 58 20 - Télex : 75 525

PORTUGAL

Comissão Nacional Portuguesa da FEM
CEMUL
A l'att. de M. le Prof. L. FARIA
Avenida António José de Almeida
I.S.T.
P - 1000 LISBOA
Tél. : (35 11) 800 067

SCHWEIZ

Schweizerisches Nationalkomitee der FEM
Verein Schweizerischer Maschinen-Industrieller VSMI
Kirchenweg 4 / Postfach 179
CH - 8032 ZÜRICH
Tél. : (411) 479 400 - Télex : 516 519

SUOMI

Finnish National Committee of FEM
Federation of Finnish Metal and Engineering Industries
Eteläranta 10
SF - 00130 HELSINKI
Tél. : (358 0) 170 922 - Télex : 124 997

SVERIGE

Swedish National Committee of FEM
Materialhanteringsgruppen inom Sveriges Mekanförbund
Storgatan 19
Box 5505
S - 11495 STOCKHOLM
Tél. : (46 81) 783 80 00 - Télex : 19 990