



FEDERATION EUROPEENNE DE LA MANUTENTION
SECTION I
HEAVY LIFTING APPLIANCES 5752

F. E. M.
1.001
3RD EDITION
1987.10.01

RULES FOR THE DESIGN OF HOISTING APPLIANCES

BOOKLET 3

CALCULATING THE STRESSES IN STRUCTURES

The total 3rd Edition comprises booklets 1 to 8
Copyright by FEM Section I
Also available in French and German



This booklet is part of the "Rules for the design of hoisting appliances" consisting of 8 booklets :

- Booklet 1 - Object and scope
- Booklet 2 - Classification and loading on structures and mechanisms
- Booklet 3 - Calculating the stresses in structures
- Booklet 4 - Checking for fatigue and choice of mechanism components
- Booklet 5 - Electrical equipment
- Booklet 6 - Stability and safety against movement by the wind
- Booklet 7 - Safety rules
- Booklet 8 - Test loads and tolerances

and must not be used separately.

BOOKLET 3

CALCULATING THE STRESSES IN STRUCTURES

CONTENTS

	<u>Clause</u>	<u>Page</u>
INTRODUCTION	-	3- 3
THE CHOICE OF STEEL QUALITIES	3.1.	3- 4
- Assessment of the factors which influence brittle fracture	3.1.1.	3- 4
. Combined effect of longitudinal residual tensile stresses and tensile stresses from dead weight	3.1.1.1.	3- 4
. Thickness of the member	3.1.1.2.	3- 6
. Influence of cold	3.1.1.3.	3- 7
- Determination of the required steel quality group	3.1.2.	3- 7
- Steel quality	3.1.3.	3- 8
- Special rules	3.1.4.	3-10
CHECKING WITH RESPECT TO THE ELASTIC LIMIT	3.2.	3-10
- Structural members other than joints	3.2.1.	3-10
. Members subjected to simple tension or compression	3.2.1.1.	3-10
. Members subjected to shear	3.2.1.2.	3-11
. Members subjected to combined loads - Equivalent stress	3.2.1.3.	3-12
- Case of joints	3.2.2.	3-13
. Riveted joints	3.2.2.1.	3-13
. Bolted joints	3.2.2.2.	3-14
.. General	3.2.2.2.0.	3-14
.. Joints made with tension bolts with controlled tightening	3.2.2.2.1.	3-14
.. Bolted joints subjected to forces acting parallel to the joint plane	3.2.2.2.2.	3-18
. Welded joints	3.2.2.3.	3-20
CHECKING MEMBERS SUBJECT TO CRIPPLING	3.3.	3-22
CHECKING MEMBERS SUBJECT TO BUCKLING	3.4.	3-22
CASE OF STRUCTURES SUBJECTED TO SIGNIFICANT DEFORMATION	3.5.	3-23
CHECKING MEMBERS SUBJECTED TO FATIGUE	3.6.	3-24
- Conventional number of cycles and stress spectrum	3.6.1.	3-24
- Material used and notch effect	3.6.2.	3-24
- Determination of the maximum stress σ_{max}	3.6.3.	3-24
- The ratio between the extreme stresses	3.6.4.	3-25
- Checking members subjected to fatigue	3.6.5.	3-25

APPENDICES

	<u>Article</u>	<u>Page</u>
DESIGN OF JOINTS USING HIGH-STRENGTH BOLTS WITH CONTROLLED TIGHTENING	A.3.2.2.2.2.3.	3-27
STRESSES IN WELDED JOINTS	A.3.2.2.3.	3-31
CHECKING STRUCTURAL MEMBERS SUBJECT TO CRIPPLING AND BUCKLING	A.3.3. and A.3.4	3-33 3-39
CHECKING STRUCTURAL MEMBERS SUBJECTED TO FATIGUE	A.3.6.	3-47
LIST OF SYMBOLS AND NOTATIONS	See booklet 1	

INTRODUCTION

The stresses set up in the various structural members are determined for the three cases of loading defined under section 2.3., and a check is made to ensure that there is a sufficient safety coefficient ν in respect of the critical stresses, considering the following three possible causes of failure :

- exceeding the elastic limit ;
- exceeding the critical crippling or buckling load ;
- exceeding the limit of endurance to fatigue.

The quality of the steels used must be stated and the physical properties, chemical composition and welding qualities must be guaranteed by the manufacturer of the material.

The permissible stresses for the materials used are determined as stipulated in clauses 3.2., 3.3., 3.4. and 3.6. hereunder, with reference to the critical stresses for the material.

These critical stresses are those which correspond either to the elastic limit (which in practice, involves establishing the stress corresponding to a critical limit for elongation), or to the critical stress for crippling or buckling, or, in the case of fatigue, to the stress for which the probability of survival, under tests, is 90 %.

The stresses in the structural members shall be calculated on the basis of the different cases of loading envisaged under section 2.3. by applying conventional strength of materials calculation procedures.

The sections of metal to be considered shall be the gross sections (i.e. without deducting the areas of holes) for all parts which are subjected to compression loads (1), and the net sections (i.e. with the areas of holes deducted) for all parts subjected to tensile loads.

In the case of a member subjected to bending, a half-net section should be assumed, taking the net section in parts under tension and the gross section in parts under compression. To simplify the calculations, however, one may use either the section modulus of the net section or the section modulus computed for the half-net section, using as centre of gravity of the section that of the gross section.

(1) The area of the holes shall be included in the cross-sectional area A_c , when they are filled by a rivet or a bolt.

THE CHOICE OF STEEL QUALITIES

The verifications required in the design rules for the safety of the structure against yielding, instability and fatigue failure do not guarantee safety against brittle fracture.

In order to obtain sufficient safety against brittle fracture, a steel quality has to be chosen depending on the conditions influencing brittle fracture.

The most important influences on the sensitivity to brittle fracture in steel structures are :

- A. Combined effect of longitudinal residual tensile stresses with tensile stresses from dead load.
- B. Thickness of the member.
- C. Influence of cold.

Influences A, B, and C are valued with points. The required steel quality depends on the sum of these points.

3.1.1.

ASSESSMENT OF THE FACTORS WHICH INFLUENCE BRITTLE FRACTURE

In the following, influences A, B, and C in paragraph 3.1. are described and quantified.

3.1.1.1.

INFLUENCE A : COMBINED EFFECT OF LONGITUDINAL RESIDUAL TENSILE STRESSES WITH STRESSES FROM DEAD WEIGHT

Equations for lines I, II and III in figure 3.1.1.1.

σ_a = permissible tensile stress with respect to the elastic limit, loading case I.

Line I : no welds, or only transverse welds

$$Z_A = \frac{\sigma_G}{0,5 \cdot \sigma_a} - 1$$

σ_G = tensile stress from permanent load, e.g. from dead weight

valid only for $\sigma_G \geq 0,5 \cdot \sigma_a$

Line II : longitudinal welds

Z_A = assessing coefficient for influence A

$$Z_A = \frac{\sigma_G}{0,5 \cdot \sigma_a}$$

Line III : accumulation of welds

$$Z_A = \frac{\sigma_G}{0,5 \cdot \sigma_a} + 1$$

The danger of brittle fracture is increased by high stress concentrations, in particular by 3-axial tensile stresses, as is the case with an accumulation of welds.

If members with low-stresses are stress relieved after welding (approx 600-650° C) line I can be used for all types of welds.

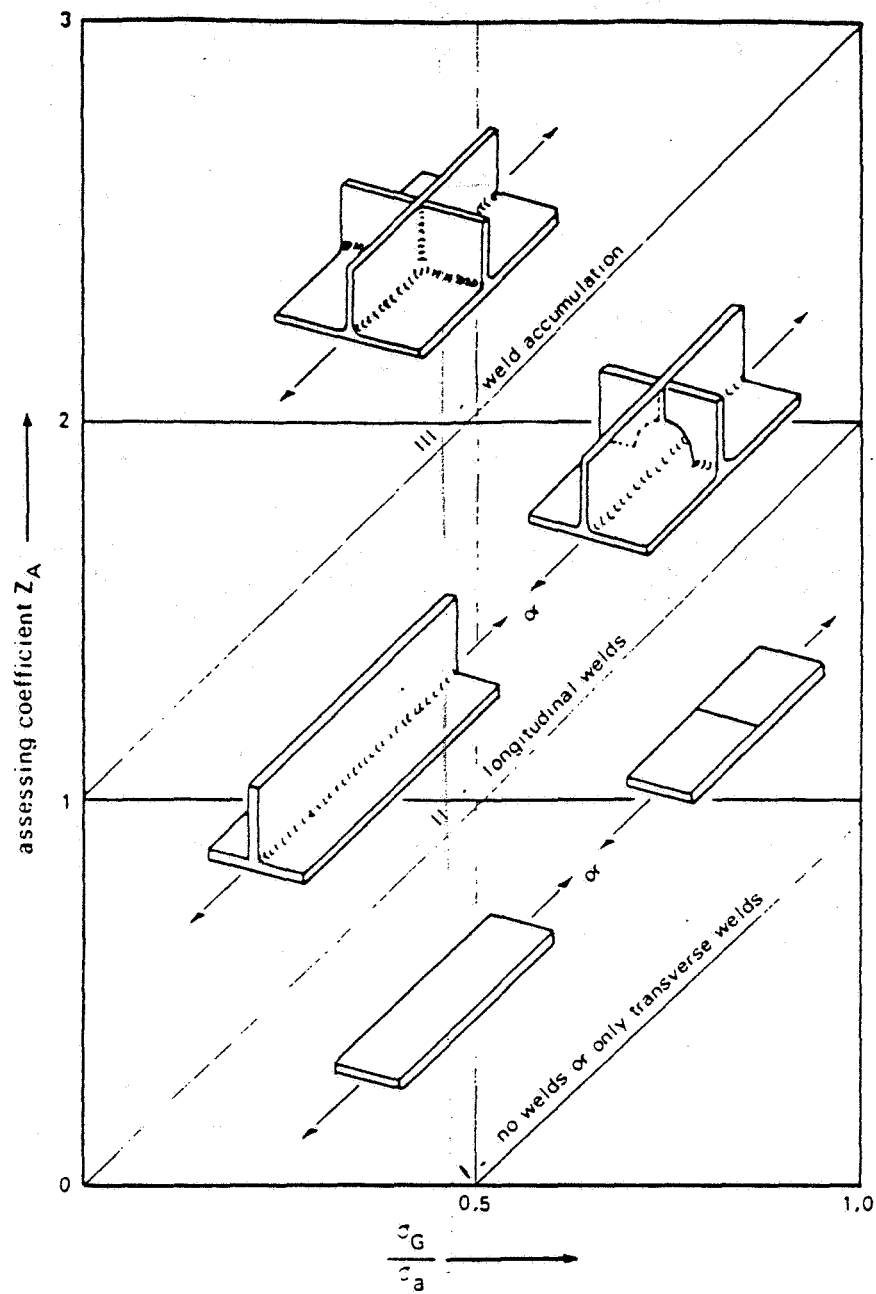

Figure 3.1.1.1.

Z_A in terms of stresses and welds

3.1.1.2. INFLUENCE B : THICKNESS OF MEMBER t

t = Thickness of member in mm

Z_B = Assessing coefficient for influence B

from t = 5 to t = 20 mm

$$Z_B = \frac{9}{2500} t^2$$

from t = 20 to t = 100 mm

$$Z_B = 0,65 \sqrt{t-14,81} - 0,05$$

t mm	Z _B	t mm	Z _B	t mm	Z _B
5	0,1	16	0,9	60	4,1
6	0,15	20	1,45	65	4,55
7	0,2	25	2,0	70	4,8
8	0,25	30	2,5	75	5,0
9	0,3	35	2,9	80	5,2
10	0,4	40	3,2	85	5,4
12	0,5	45	3,5	90	5,6
15	0,8	50	3,8	95	5,8
		55	4,0	100	6,0

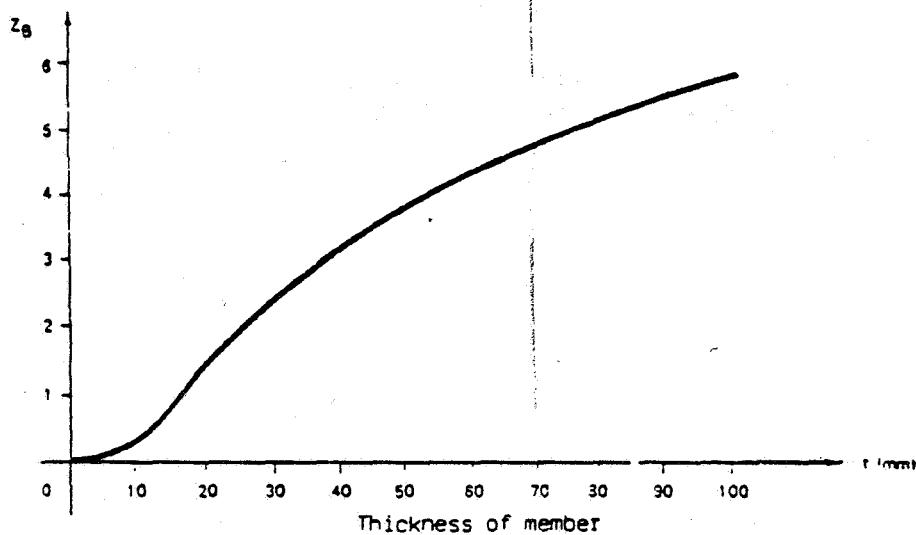

Figure 3.1.1.2.

Assessing coefficient. Z_B = f (t)

For rolled sections an idealised thickness t* is to be used. This is

for round sections . $t^* = \frac{d}{1,8}$

for square sections : $t^* = \frac{t}{1,8}$

for rectangular sections . $t^* = \frac{b}{1,8}$

where b represents the larger side of the rectangle and the ratio of the sides

$\frac{b}{t} \leq 1,8$

For $\frac{b}{t} > 1,8$, t* = t.

3.1.1.3. INFLUENCE C : INFLUENCE OF COLD

The lowest temperature at the place of erection of the crane determines the classification. This temperature is generally lower than the working temperature.

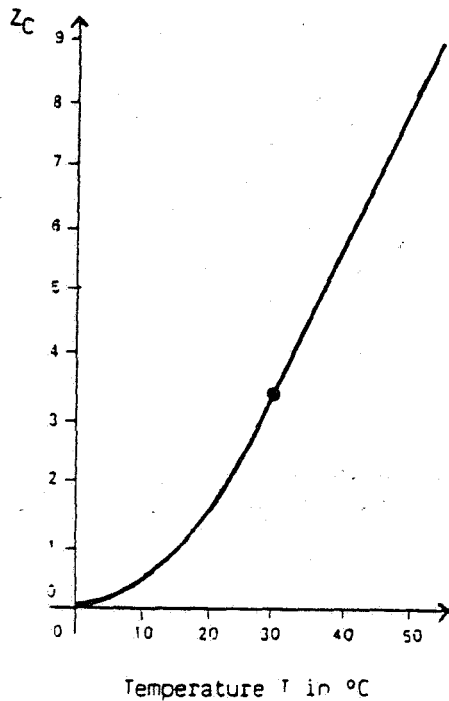

Figure 3.1.1.3.

Assessing coefft. $Z_C = f(T)$

T = Temperature at the place of erection in °C

Z_C = Assessing coefft. for influence C

from T = 0°C to T = - 30°C take

$$Z_C = \frac{6}{1600} \cdot T^2$$

from T = - 30°C to T = - 55°C take

$$Z_C = \frac{- 2,25 \cdot T - 33,75}{10}$$

T °C	Z_C	T °C	Z_C
0	0,0	- 30	3,4
- 5	0,1	- 35	4,5
- 10	0,4	- 40	5,6
- 15	0,8	- 45	6,7
- 20	1,5	- 50	7,9
- 25	2,3	- 55	9,0

3.1.2. DETERMINATION OF THE REQUIRED STEEL QUALITY GROUP

It is the sum of assessing coefficients from paragraph 3.1.1. which determines the minimum required quality for the steel structure.

Table 1. 3.1.2. shows the classification of the quality groups in relation to the sum of the assessing coefficients.

If the sum of the assessing coefficients is higher than 16 or if the required steel quality cannot be obtained, special measures will be necessary to obtain the steel quality necessary for safety against brittle fracture which will have to be determined with material experts.

Table T.3.1.2.

Classification of quality groups in relation
to the sum of the assessing coefficients

Sum of the assessing coefficients from paragraph 3.1.1. $\Sigma Z = Z_A + Z_B + Z_C$	Quality group corresponding in table T.3.1.3.
≤ 2	1
≤ 4	2
≤ 8	3
≤ 16	4

3.1.3

QUALITY OF STEELS

The quality of steels in these design rules is the property of steel to exhibit a ductile behaviour at determined temperatures.

The steels are divided into four quality groups. The group in which the steel is classified, is obtained from its notch ductility in a given test and temperature.

Table T.3.1.3. comprises the notch ductility values and test temperatures for the four quality groups.

The indicated notch ductilities are minimum values, being the mean values from three tests, where no value must be below 20 Nm/cm².

The notch ductility is to be determined in accordance with V-notch impact tests to ISO R 148 and Euronorm 45-63.

Steels of different quality groups can be welded together.

T is the test temperature for the V-notch impact test.

T is the temperature at the place of erection of the crane.

T_c and T are not directly comparable as the V-notch impact test imposes a more unfavourable condition than the loading on the crane in or out of service.

Table T.3.1.3.

Quality groups

Quality group	Notch ductility measured in ISO sharp notch test ISO = $\frac{J_{100}}{2}$ in Nm/cm ²	Test temperature T _c °C	Steels, corresponding to the quality group Designation of steels	Standard
1	-	-	Fe 360 - A	Euronorm 25
			Fe 430 - A	
			St 37 - 2	DIN 17100
			St 44 - 2	
			E 24 - 1	
43 A 50 B *	BS 4360 1972			
2	35	- 20°	Fe 360 - B	Euronorm 25
			Fe 430 - B	
			Fe 510 - B	
			R St 37-2	DIN 17100
			St 44-2	
			E 24 (A37) - 2	
			E 26 (A42) - 2	
E 36 (A52) - 2	BS 4360 1972			
40 B 43 B *				
3	35	± 0°	Fe 360 - C	Euronorm 25
			Fe 430 - C	
			Fe 510 - C	
			St 37 - 3U	DIN 17100
			St 44 - 3U	
			St 52 - 3U	
			E 24 (A37) - 3	NF A 35-501
E 26 (A42) - 3				
E 36 (A52) - 3	BS 4360 1972			
40 C 43 C *				
50 C 55 C				
4	35	- 20°	Fe 360 - D	Euronorm 25
			Fe 410 - D	
			Fe 510 - D	
			St 37 - 3N	DIN 17100
			St 44 - 3N	
			St 52 - 3N	
			E 24 (A37) - 4	NF A 35-501
E 26 (A42) - 4				
E 36 (A52) - 4	BS 4360 1972			
40 D 43 D *				
50 D 55 E				

- * The test requirements of steels to BS.4360 do not in all cases agree with the Euronorm and other national standards, and the guaranteed impact test properties for steels to BS.4360 may be different to other steels in the same quality group. Impact test properties are stated in BS.4360 and where the requirements are different from those guaranteed in BS.4360, agreement must be obtained from the steel suppliers.

3.1.4.

SPECIAL RULES

In addition to the above provisions for the choice of the steel quality, the following rules are to be observed :

- 1 - Non killed steels of group 1 shall be used for load carrying structures only in case of rolled sections and tubes not exceeding 6 mm thickness.
- 2 - Members of more than 50 mm thickness, shall not be used for welded load carrying structures unless the manufacturer has a comprehensive experience in the welding of thick plates. The steel quality and its testing has in this case to be determined by specialists.
- 3 - If parts are cold bent with a radius/plate thickness ratio < 10 the steel quality has to be suitable for folding or cold flanging.

3.2.

CHECKING WITH RESPECT TO THE ELASTIC LIMIT

For this check, a distinction is made between the actual members of the structure and the riveted, bolted or welded joints.

3.2.1.

STRUCTURAL MEMBERS OTHER THAN JOINTS

3.2.1.1.

MEMBERS SUBJECTED TO SIMPLE TENSION OR COMPRESSION

- 1) Case of steels for which the ratio between the elastic limit σ_E and the ultimate tensile strength σ_R is $< 0,7$.

The computed stress σ must not exceed the maximum permissible stress σ_a obtained by dividing the elastic limit stress σ_E by a coefficient ψ_E which depends upon the case of loading as defined under section 2.3.

The values of ψ_E and the permissible stresses are :

Values of ψ_E	Case I 1,5	Case II 1,33	Case III 1,1
Permissible stresses σ_a	$\frac{\sigma_E}{1,5}$	$\frac{\sigma_E}{1,33}$	$\frac{\sigma_E}{1,1}$

For carbon steels of current manufacture A.37 - A.42 - A.52 (also called E.24 - E.26 - E.36 or Fe 360 - Fe 510) the critical stress σ_E is conventionally taken as that which corresponds to an elongation of 0,2 %.

Table T.3.2.1.1.

Values of σ_E and σ_a for steels A.37 - A.42 - A.52

STEELS	Elastic limit σ_E N/mm ²	Maximum permissible stresses : σ_a		
		Case I	Case II	Case III
		N/mm ²	N/mm ²	N/mm ²
E.24 (A.37, Fe 360)	240	160	180	215
E.26 (A.42)	260	175	195	240
E.36 (A.52, Fe 510)	360	240	270	325

2) Case of steels with high elastic limit ($\sigma_E/\sigma_R > 0,7$)

For steels with high elastic limit where the ratio $\frac{\sigma_E}{\sigma_R}$ is greater than 0.7, the use of the σ_E coefficients does not ensure a sufficient margin of safety. In this case a check can be made that the permissible stress σ_a given by the formula below is not exceeded :

$$\sigma_a = \frac{\sigma_E + \sigma_R}{\sigma_E \cdot 52 + \sigma_R \cdot 52} \cdot \sigma_{a52}$$

where

σ_E and σ_R are the elastic limit and the ultimate tensile strength of the steel considered

$\sigma_{E.52}$ and $\sigma_{R.52}$ these same stresses for steel A.52, i.e. 360 N/mm² and 510 N/mm²

σ_{a52} the permissible stress for steel A.52 in the case of loading considered.

3.2.1.2. MEMBERS SUBJECTED TO SHEAR

The permissible stress in shear τ_a has the following value :

$$\tau_a = \frac{\sigma_a}{\sqrt{3}}$$

σ_a being the permissible tensile stress.

3.2.1.3.

MEMBERS SUBJECTED TO COMBINED LOADS - EQUIVALENT STRESS

σ_x , σ_y and τ_{xy} being respectively the two normal stresses and the shear stress at a given point, a check shall be made :

- 1 - that each of the two stresses σ_x and σ_y is less than σ_a and that τ_{xy} is less than τ_a
- 2 - that the equivalent stress σ_{CD} is less than σ_a , i.e. :

$$\sigma_{CD} = \sqrt{\sigma_x^2 + \sigma_y^2 - \sigma_x \sigma_y + 3 \tau_{xy}^2} \leq \sigma_a$$

When using this formula, a simple method is to take the maximum values σ_x , σ_y and τ_{xy} . But, in fact, such a calculation leads to too great an equivalent stress if it is impossible for the maximum values of each of the three stresses to occur simultaneously.

Nevertheless, the simple calculation method, being conservative, is always acceptable.

If it is desired to calculate more precisely, it is necessary to determine the most unfavourable practical combination that may occur. Three checks must then be made by calculating successively the equivalent stress resulting from the three following combinations :

σ_x max and the corresponding stresses σ_y and τ_{xy}

σ_y max and the corresponding stresses σ_x and τ_{xy}

τ_{xy} max and the corresponding stresses σ_x and σ_y

Note : It should be noted that when two out of the three stresses are approximately of the same value, and greater than half the permissible stress, the most unfavourable combination of the three values may occur in different loading cases from those corresponding to the maximum of each of the three stresses.

Special case :

- Tension (or compression) combined with shear

The following formula should be checked :

$$\sqrt{\sigma^2 + 3 \tau^2} \leq \sigma_a$$

3.2.2.

CASE OF JOINTS

3.2.2.1. RIVETED JOINTS

1 - Rivets in shear

Taking the effect of the clamping force into account, the calculated shearing stress τ must not exceed :

$$\tau = 0,6 \sigma_a \text{ in the case of single shear}$$

$$\text{and } \tau = 0,8 \sigma_a \text{ in the case of double or multiple shear}$$

where σ_a is the permissible tensile stress of the metal used for the rivet.

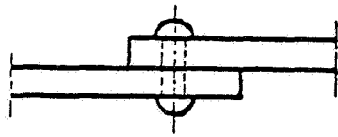

single shear

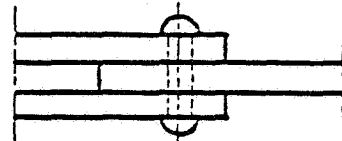

double or multiple shear

2 - Rivets in tension

The calculated tensile stress σ must not exceed the value :

$$\sigma = 0,2 \sigma_a$$

3 - Rivets loaded in tension and shear

The following conditions must be checked :

$$\sigma \leq 0,2 \sigma_a$$

$$\text{and } \tau \leq 0,6 \sigma_a \text{ for single shear}$$

$$\text{or } \tau \leq 0,8 \sigma_a \text{ for double shear}$$

4 - Limit of bearing pressure

The bearing pressure in the walls of holes σ_n must not exceed :

$$\sigma_n \leq 1,5 \sigma_a \text{ for single shear}$$

$$\sigma_n \leq 2 \sigma_a \text{ for double shear}$$

5 - Notes concerning riveted joints

- a) Rivets subjected to tension should be avoided, particularly for the main members ;
- b) all joints must have at least two rivets aligned in the direction of the force.

3.2.2.2. BOLTED JOINTS

3.2.2.2.0. GENERAL

Bolted joints may be subjected to stresses due to forces acting perpendicular to the joint (joints by tension bolts), due to forces acting parallel to the joint surfaces, and due to forces acting simultaneously perpendicular and parallel to the joint surface.

3.2.2.2.1. JOINTS MADE WITH TENSION BOLTS WITH CONTROLLED TIGHTENING

1 - General

A joint by tension bolts with controlled tightening is a joint in which the main tension is in the direction of the axis of the bolt, screw or threaded rod and which has been subject to a tightening effect, applied in the absence of any external load, which is recommended for all joints subjected to fatigue.

Care must be taken to ensure that the bolt is not subjected to shear loading. These bolts do not come into the category of H.S. bolts but may be used if they fulfil the conditions of 3.2.2.2.3.

Care should be taken to ensure that the bolts are correctly tightened and that the tightening is permanent (tolerance +/- 10 %). Factor $\Omega = 1.1$ is introduced to take account of tolerances.

During the application of the initial tightening on the bolt, under the combined effect of tension and torsional loading the stress should not exceed 80 % of the elastic limit, taking account of the scatter in applying the initial tightening.

2 - Calculation of the permissible load on joints

A - Calculation of the initial tightening force to be used

a) Tightening with twist

$$\sigma_b = \sqrt{\sigma_p^2 + 3 \tau_b^2} \leq 0,8 \sigma_E$$

where :

$$\tau_b = \frac{2d_2 \sigma_p}{d_t} \left(\frac{p_a}{\pi d_2} + 1,155 \mu \right)$$

where :

σ_p = theoretical tensile stress under the tightening effect

τ_b = torsional stress under the tightening effect

d_2 = diameter of the root of the thread

d_t = nominal diameter of the bolt

p_a = thread pitch

μ = friction coefficient in the threads

σ_E = elastic limit of the bolt metal

b) Tightening without twist

$$\sigma_b \leq 0,8 \sigma_E$$

B - Permissible load F_1 on the joint

Two checks are to be made :

- a) Under the maximum load, taking into account the safety coefficient κ and κ' , the elastic limit of the bolt must not be exceeded.

determine :
$$\sigma'_1 = \sqrt{\sigma_E^2 - 3\tau_b^2}$$

check that :
$$\frac{F_1}{S_b} \leq \frac{\sigma'_1 - \sigma_D}{\kappa \kappa' \delta_b}$$

where

S_b = section of the root < section of the shank.

$$\delta_b = \frac{\Delta l_1}{\Delta l_1 + \Delta l_2}$$

Δl_1 = shortening of the elements to be tightened under the action of the tightening force

Δl_2 = lengthening of bolt under the action of the tightening force.

For assembled steel parts, the section to be considered for Δl_1 :

$$S_{eq} = \frac{\pi}{4} \left[\left(S_1 + \frac{l_\kappa}{10} \right)^2 - D_t^2 \right]$$

where

S_1 = bearing diameter under head

l_κ = length of tightened parts

D_t = diameter of bolt holes

For bolts whose shank diameter differs considerably from the root diameter of the thread and where there is an appreciable threaded length remaining in the part submitted to stress, a complete calculation of Δl_2 should be made.

- b) Under the maximum load with application of coefficients Ω , κ' and κ'' separation of the parts should not occur.

$$\sigma_1 = \frac{F_1}{S_b} \leq \frac{\sigma_D}{\kappa' \kappa'' (1 - \delta_b) \Omega}$$

Safety coefficients κ , κ' and κ''

κ depends on the surface state of the parts to be tightened (machined surface $\kappa = 1$)

κ' corresponds to safety in relation to the elastic limit in accordance with table 3.2.2.2.

κ'' corresponds to safety against separation of the parts.

Table I.3.2.2.2.

	Case I	Case II	Case III
κ'	1,50	1,33	1,1
κ''	1,3	1	1

Note : The coefficients κ' and κ'' should be applied to the most unfavourable condition arising from the scatter in applying the initial tightening effort.

C - Checking for fatigue

Checking bolts for fatigue is carried out solely for case I loads.

Under the effect of the service load F_1 , the true tensile stress varies between the values :

$$\sigma_p \text{ and } \sigma_p + \frac{F_1 \cdot \delta_b}{S_b}$$

The following equation must be verified :

$$\sigma_1 = \frac{F_1}{S_b} \ll \frac{2 \sigma_A}{\delta_b}$$

σ_A is the amplitude of the maximum permissible stress for fatigue given in the following graph.

For any other type of bolt or design method the σ_A value should ensure at least an equivalent level of safety against fatigue.

Any conformity tests should be carried out according to ISO specification 3800/1 with $\sigma_m = 0,8 R_E$ ($R_E = \sigma_E$).

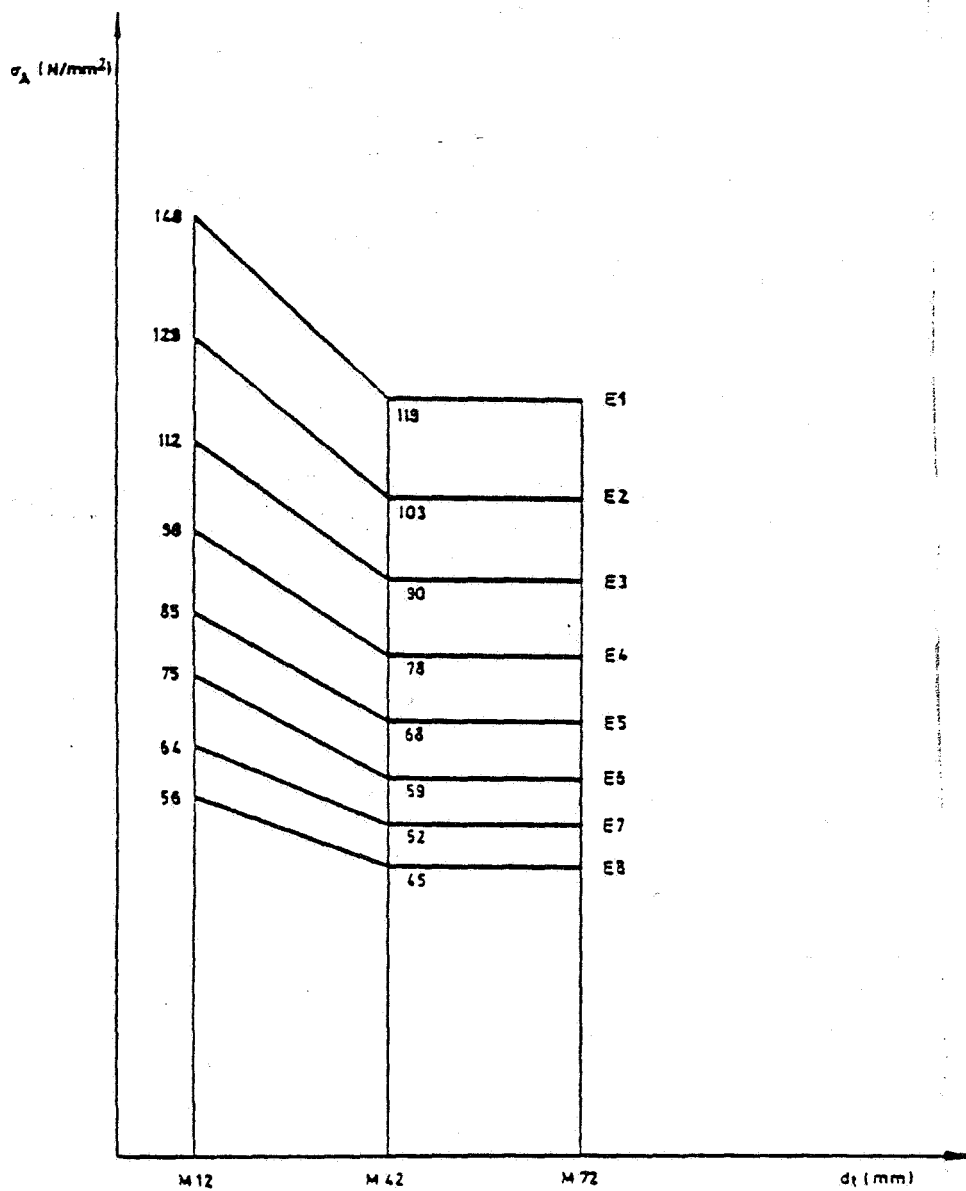

Amplitude of maximum permissible fatigue stress

Graph for ISO bolts

- standard thread
- classes 8.8, 10.9, 12.9
- cold rolled thread with heat treatment after rolling

3.2.2.2.2. BOLTED JOINTS SUBJECTED TO FORCES ACTING PARALLEL TO THE JOINT PLANE

1 - Bolts subjected to shear (fitted bolts)

Preferably for non-fluctuating stresses with and without preload.

The following checks presuppose that the bolting has been effected under proper conditions, i.e. using fitted bolts (turned or cold finished) with ISO tolerances and the shanks of which bear against the full length of holes drilled in the parts being assembled.

Holes must be drilled and reamed with the ISO tolerances.

Black bolts are permitted only for secondary joints which do not transmit heavy loads. They are prohibited for joints subject to fatigue.

The calculated stress τ on the shank shall not exceed the values given for rivets in clause 3.2.2.1.1-.

The bearing pressure shall not exceed the values indicated in clause 3.2.2.1.4-.

2 - Bolts subjected to combined tension and shear

A check shall be made that :

$$\begin{aligned} & \sigma \leq 0,65 \sigma_a \\ \text{and} \quad & \tau \leq 0,6 \sigma_a \quad \text{for single shear} \\ \text{or} \quad & \tau \leq 0,8 \sigma_a \quad \text{for double shear} \\ \text{and that} \quad & \sqrt{\sigma^2 + 3 \tau^2} \leq \sigma_a \end{aligned}$$

The permissible stress in a bolt is limited to :

$$\begin{aligned} \sigma_a &= 0,7 \sigma_{E(0,2)} \quad \text{for normal execution} \\ \sigma_a &= 0,8 \sigma_{E(0,2)} \quad \text{for a construction which prevents stripping} \\ & \quad \text{the thread.} \end{aligned}$$

where $\sigma_{E(0,2)}$ is the 0,2 % proof stress of the metal constituting the bolt.

For shear

However, welds, t

Table T. according

Max

LEB

3 - Joints using high strength bolts with controlled tightening (H.S.)

This type of joint is recommended for assemblies subjected to fatigue main loads are parallel to joint faces. Members joined by H.S. bolts subjected to the following types of loads :

A - Loads acting in the plane of the joint (symbol T)

In this case, the loads tend to make the parts in contact slip a force is transmitted by friction. To determine the permissible load bolt T_a which can be transmitted by friction, the tensile force exists in the bolt after tightening must be considered. This is by the coefficient of friction μ of the contact surfaces, and the coefficients v_T which are the same as those in clause (3.2.1.1.) to this limiting force, i.e.

$$v_T = 1,5 \quad \text{for case I loading}$$

$$= 1,33 \quad \text{for case II loading}$$

$$= 1,1 \quad \text{for case III loading}$$

This may be expressed : $T_a = \frac{\mu \cdot F}{v_T} \cdot m$, m being the number of friction surfaces.

The tension, F, in a bolt depends upon the tightening torque ; μ depends upon the metal constituting the members, the state of contact, and the method of preparation. Appendix A - 3.2.2.2.2 information on this subject.

B - Forces perpendicular to the plane of the joint (symbol N)

The checking by calculation of the forces perpendicular to the surface shall be carried out in accordance with clause 3.2.2.2.1.

If the bolted joint is subjected to an external couple M, the tension has to be determined at the bolt which is subjected to the maximum load, and, where applicable, added to the existing tensile load N.

C - Combined loads of the T, N and M types

Two checks must be made :

a) That, for the most highly stressed bolt, the sum of the tensile load due to N and M loadings remains less than the permissible tensile load as defined in 3.2.2.2.2.

b) That the mean load which is transmitted by friction is less than the following value :

$$T = \frac{\mu (F - N)}{v_T} \cdot m$$

Types of loading

Longitudinal equivalent stresses for all types of welds

Transverse tensile stresses
Butt-welds and special quality K-welds
Ordinary quality K-welds
Fillet welds

Transverse compressive stresses
Butt-welds and K-welds
Fillet welds

Stresses in lap joints or tapes of welds

D - Deta

3.3.

CHECKING MEMBERS SUBJECT TO CRIPPLING

For
(cro

For

1st
load

a) t
b) 6
d

2nd
dicu

The r
pond
figu
two c

a) th
b) on
th
ta

This
the r
bolts
rows

E - Execu

It mu
joint
with
prepa

See a

The guiding principle shall be that parts subject to crippling must be checked with the same safety margin as that adopted in respect of the elastic limit. In other words, having determined the practical crippling stress, the maximum allowable stress shall be the crippling stress divided by the appropriate coefficient of 1,5 or 1,33 or 1,1 specified in 3.2.1.1.

The choice of a practical method of calculation is left to the manufacturer. He must state the origin of the method chosen.

If the method chosen involves multiplying the computed stress by a crippling coefficient ω depending upon the slenderness ratio of the member and then checking that this amplified stress remains less than a certain allowable stress, the value of ω to be chosen for this allowable stress shall be as specified in 3.2.1.1.

Note : Appendix A-3.3. shows how to apply various classical methods of calculation in accordance with the above requirements.

3.4.

CHECKING MEMBERS SUBJECT TO BUCKLING

In determining the new buckling safety coefficients, stated below, it was found that flat plates under compressive stresses equally distributed over the surface are exposed to a greater danger of buckling than plates under stresses due to compression to tension over the plate width.

In consequence, safety against buckling was made dependent on the ratio of the stresses at the plate edges (appendix A-3.4.)

In addition it was found necessary to determine the critical buckling stress for circular cylinders and the spacing and moment of inertia of the transverse stiffeners in order to avoid too great divergences in the effective safety due to the use of highly divergent data in technical literature.

It shall be verified that the calculated stress is not higher than the critical buckling stress divided by the following coefficients ω :

	Case	Buckling safety coefficient ω
Buckling of plane members	I	1,70 + 0,175 ψ
	II	1,50 + 0,125 ψ
	III	1,35 + 0,075 ψ
Buckling of curved members : Circular cylinders (e.g. tubes)	I	1,70
	II	1,50
	III	1,35

The edge-stresses ratio ψ varies between + 1 and - 1.

Appendix A.3.4. gives the procedure for determining the critical buckling stress.

2.3. WELDED
In welded
character
It must be
and compr

CASE OF STRUCTURES SUBJECTED TO SIGNIFICANT DEFORMATION

In this case the stresses in the members may not be proportional to the forces which cause them due to the deformation of the structure as a result of the application of these forces.

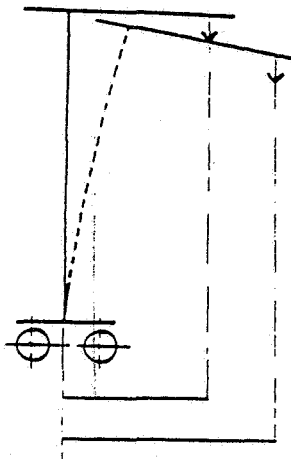

This is the case, for example, with the stresses produced in the column of a crane (illustrated diagrammatically) where it is clear that the moment in the column is not proportional to the forces applied because of deformations which increase their moment arm.

In this case the calculation is made as follows :

1 - First make the checks required by clauses 3.2. - 3.3. - 3.4. calculating the stresses resulting from the various cases of loading and checking that there is a sufficient safety margin in relation to the critical stresses (elastic limit, crippling, buckling). In the calculation of the stresses account is taken of the deformation due to the loads on the structure.

2 - A further check is also carried out by calculating the stresses resulting from the application of the loads multiplied by the coefficient ν of the case of loading considered and taking into account the deformations resulting from the application of these increased loads and checking that the stresses thus calculated remain less than the critical stresses for the elastic limit, for crippling and for buckling.

However, to take account of the fact that the variable loads S_V (loads due to the hoisted load multiplied by Ψ , to the wind and to horizontal movements) are more dangerous than the constant load due to the dead weight S_G , a check can be made in practice by considering two cases as follows :

1 - When the effects of the dead weight S_G and of the variable load S_V lead to deformation in opposite directions :

Determine the stress σ_G resulting from the application of the dead weight S_G (without amplification) and σ_V resulting from the variable loads S_V , multiplied by the coefficient ν corresponding to the case considered (clause 3.2. elastic limit, 3.3. crippling, 3.4. buckling) and check that this stress is less than the critical value i.e. :

$$\sigma \text{ resulting from } (S_G + \nu S_V) \leq \sigma_{cr}$$

2 - When the dead weight and the variable load lead to deformations in the same direction : determine the stress resulting from the application of the variable load multiplied by the coefficient ν and of the dead weight multiplied by the coefficient :

$$\nu' = 1 + (\nu - 1) r$$

where $r = \frac{\sigma_G}{\sigma_G + \sigma_V}$ calculated in the initial stage of the deformations.

We then have : σ resulting from $(\nu' S_G + \nu S_V) \leq \sigma_{cr}$.

3.6.

CHECKING MEMBERS SUBJECTED TO FATIGUE

Danger of fatigue occurs when a member is subjected to varying and repeated loads.

Fatigue strength is calculated by considering the following parameters :

- 1 - the conventional number of cycles and the stress spectrum to which the member is subjected ;
- 2 - the material used and the notch effect at the point being considered ;
- 3 - the extreme maximum stress σ_{\max} which can occur in the member ;
- 4 - the ratio κ between the values of the extreme stresses.

3.6.1.

CONVENTIONAL NUMBER OF CYCLES AND STRESS SPECTRUM

The number of cycles of variations of loading and the spectrum of stresses to be taken into consideration are discussed in clause 2.1.2.2. and in clause 2.1.2.3.

These two parameters are taken into account when considering solely the group in which the member is classified in accordance with clause 2.1.4.

3.6.2.

MATERIAL USED AND NOTCH EFFECT

The fatigue strength of a member depends upon the quality of the material used and upon the shape and the method of making the joints. The shapes of the parts joined and the means of doing it have the effect of producing stress concentrations (or notch effects) which considerably reduce the fatigue strength of the member.

Appendix A-3.6. gives a classification of various joints according to their degree of stress concentration (or notch effect).

3.6.3.

DETERMINATION OF THE MAXIMUM STRESS σ_{\max}

The maximum stress, σ_{\max} is the highest stress in absolute value (i.e. it may be tension or compression) which occurs in the member in loading case I referred to in clause 2.3.1. without the application of the amplifying coefficient γ_c .

When checking members in compression for fatigue the crippling coefficient, ω , given in clause 3.3. should not be applied.

3.6.4.

THE RATIO κ BETWEEN THE EXTREME STRESSES

This ratio is determined by calculating the extreme values of the stresses to which the component is subjected under case I loadings.

The ratio may vary depending upon the operating cycles but it errs on the safe side to determine this ratio κ by taking the two extreme values which can occur during possible operations under case I loadings.

If σ_{\max} and σ_{\min} are the algebraic values of these extreme stresses, σ_{\max} being the extreme stress having the higher absolute value, the ratio κ may be written :

$$\kappa = \frac{\sigma_{\min}}{\sigma_{\max}} \text{ or } \frac{\tau_{\min}}{\tau_{\max}} \text{ in the case of shear.}$$

This ratio, which varies from + 1 to - 1, is positive if the extreme stresses are both of the same sense (fluctuating stresses) and negative when the extreme stresses are of opposite sense (alternating stresses).

3.6.5.

CHECKING MEMBERS SUBJECTED TO FATIGUE

Using the parameters defined in clauses 3.6.1. to 3.6.4. the adequacy of the structural members and of the joints subjected to fatigue is ensured by checking that the stress σ_{\max} , as defined in clause 3.6.3. is not greater than the permissible stress for fatigue of the members under consideration.

This permissible stress for fatigue is derived from the critical stress, defined as being the stress which, on the basis of tests made with test pieces, corresponds to a 90 % probability of survival to which a coefficient of safety of 4/3 is applied thus :

$$\sigma_a \text{ for fatigue} = 0,75 \sigma \text{ at } 90 \% \text{ survival.}$$

The determination of these permissible stresses having regard to all these considerations is a complex problem and it is generally advisable to refer to specialised books on the subject.

Appendix A-3.6. gives practical indications, based on the results of research in this field, on the determination of permissible stresses for A.37 - A.42 and A.52 steels, according to the various groups in which the components are classified, and the notch effects of the main types of joints used in the manufacture of hoisting appliances.

APPENDIX A - 3.2.2.2.2.3.

DESIGN OF JOINTS USING HIGH STRENGTH BOLTS WITH CONTROLLED TIGHTENING

Clause 3.2.2.2.3. determines the general requirements to be observed for the execution of joints with high strength bolts.

This appendix gives some directions on the preparation of the surfaces to be joined, the friction coefficients obtained and the tightening methods.

Coefficient of friction μ

The coefficient of friction used for the calculation of the force transmitted by friction depends upon the joined material and upon the preparation of the surfaces.

A minimum preparation before jointing will consist in removing every trace of dust, rust, oil and paint by energetic brushing with a clean metallic brush. Oil stains must be removed by flame cleaning or by the application of suitable chemical products (carbon tetrachloride, for instance).

A more careful preparation will increase the coefficient of friction. This could be sandblasting, shotblasting or oxy-acetylene flame cleaning done not more than five hours before tightening ; brushing must be done just prior to jointing.

The coefficients of friction are given in the following table.

Table T.A. 3.2.2.2.3.1.

Values of μ

Joined material	Normally prepared surfaces (degreasing and brushing)	Specially prepared surfaces (flame-cleaned, shot or sand-blasted)
E-24 (A.37) Fe 360	0,30	0,50
E-26 (A.42)	0,30	0,50
E-36 (A.52) Fe 510	0,30	0,55

It is necessary to insert two washers, one under the bolt head, the other under the nut. These washers must have a 45° bevel, at least on the internal rim, and turned towards the bolt head or the nut. They must be heat-treated in order that their hardness shall be at least equal to that of the metal constituting the bolt

Bolt tightening

The value of the tension induced in the bolt must reach the value determined by calculation.

This tension, resulting from tightening, can be measured by calculation of the torque to be applied to the bolt and given by the formula :

$$M_a = 1,10 C \cdot d \cdot F$$

where

M_a is the torque to be applied in Nm

d is the nominal diameter of the bolt in mm

F is the nominal tension to be induced in the bolt kN

C is a coefficient depending on the thread form, the friction coefficient of the threads and between the nut and the washer.

With metric-threaded bolts and washers as delivered (slightly oiled, without rust or dust) :

$$C = 0,18$$

The tensile stress in the bolt must not exceed that defined under clause 3.2.2.2.2.

Value of the tensile stress area of the bolts

When determining the stress in the bolt, the tensile stress area shall be calculated by taking the arithmetic mean of the core (minor) diameter and the effective thread diameter. These values are given in the following table :

Nominal diameter (mm)	8	10	12	14	16	18	20	22	24	27	30
Tensile stress area (mm ²)	36,6	58	84,3	115	157	192	245	303	353	459	561

Quality of the bolts

Bolts used for this type of joint have a high elastic limit.

The ultimate tensile strength σ_R must be greater than the values given hereunder :

$\sigma_E 0,2$ N/mm ²	σ_R N/mm ²
< 700	> 1,15 σ_E
700 to 850	> 1,12 σ_E
> 850	> 1,10 σ_E

The diameter of holes shall not exceed by more than 2 mm the diameter of the bolt.

The following table gives per bolt and per friction surface, the values of the transmissible forces in the plane parallel to that of the joint for bolts of 1000 - 1200 N/mm² with an elastic limit of $\sigma_E = 900$ N/mm² for various friction coefficients for the steels A.37, A.42 and A.52.

To apply these figures, the number of effective friction surfaces as indicated in the drawing below must be determined.

Effective friction surfaces

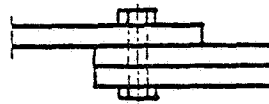
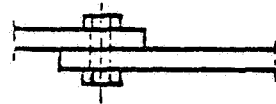

1 friction surface $m = 1$

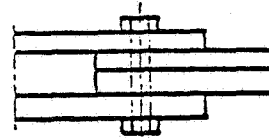
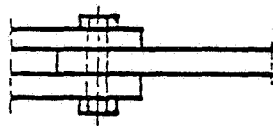

2 friction surfaces $m = 2$

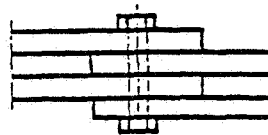

3 friction surfaces $m = 3$

Table T.A.3.2.2.2.3.2.

Transmissible forces in the plane of the joint
per bolt and per friction surface

Bolts of 1000/1200 N/mm² : $\sigma_E = 900 \text{ N/mm}^2$
with means of preventing stripping of the threads : $\sigma_a = 0,8 \sigma_E$

Bolt diameter mm	Tensile stress area mm ²	Clamping force kN	Applied torque Nm	Normally prepared surfaces			Specially prepared surfaces					
				Steels A-37, A-42, A-52 $\mu = 0,30$			Steels A-37, A-42 $\mu = 0,50$			Steel A-52 $\mu = 0,55$		
				Case I kN	Case II kN	Case III kN	Case I kN	Case II kN	Case III kN	Case I kN	Case II kN	Case III kN
10	58	41,7	82,7	8,3	9,4	11,4	13,9	15,7	18,9	15,2	17,2	20,8
12	84,3	60,6	144,0	12,1	13,6	16,5	20,2	22,8	27,5	22,2	25,0	30,3
14	115	82,7	229,0	16,5	18,6	22,5	27,5	31,0	37,6	30,2	34,2	41,4
16	157	113,0	358,0	22,6	25,5	30,8	37,7	42,5	51,4	41,5	46,8	56,5
18	192	138,0	492,0	27,6	31,0	37,6	46,0	51,8	62,7	50,6	57,0	69,0
20	245	176,0	697,0	35,2	39,7	48,0	58,5	66,1	80,0	64,5	72,7	88,0
22	303	218,0	950,0	43,6	49,3	59,7	72,5	82,0	99,0	80,0	90,2	109,0
24	353	254,0	1200,0	50,8	57,1	69,4	84,5	95,5	115,5	93,1	105,0	127,0
27	459	330,0	1760,0	66,0	74,2	90,0	110,0	124,0	150,0	121,0	136,0	165,0

For a bolt with an elastic limit of σ_E , the values of the forces and of the torques indicated in this table are to be multiplied by the ratio $\sigma_E/900$.

Where no special measures are taken to avoid stripping of the threads ($\sigma_a = 0,7 \sigma_E$) these values are to be divided by 1,14.

APPENDIX A - 3.2.2.3.

STRESSES IN WELDED JOINTS

Determining the stresses in welds is a highly complex problem primarily because of the great number of possible configurations welded joints can assume.

For this reason it is not possible, as the matter stands at present, to lay down precise directives in these Rules for the Design of Hoisting Appliances. Indeed, both the volume and the subject matter of rules relating to welding would be difficult to fit into the general context of the present design rules. It was consequently decided to include only the following general indications :

- 1 - All methods of calculation assume of necessity a properly executed joint, i.e. a weld with correct penetration and a good shape, so that the joint between the components to be assembled and the weld seam is free from discontinuity or sudden change of section as well as from craters or notches due to undercutting.

The design of the weld must be adapted to the forces to be transmitted, and specialised literature on the subject should be consulted.

It should be noted that the strength of a welded joint is significantly improved if the surface of the weld is finished by careful grinding.

- 2 - There is no need to take into consideration stress concentrations due to the design of the joint or residual stresses.
- 3 - The permissible stresses in welds are those determined under clause 3.2.2.3. and the equivalent stress σ_{cp} in the case of combined stresses (tensile or compressive) σ and shear stress τ is given by the formula :

$$\sigma_{cp} = \sqrt{\sigma^2 + 2 \tau^2}$$

In cases involving dual stresses σ_x and σ_y and the shearing stress τ_{xy} , the following formula is applied :

$$\sigma_{cp} = \sqrt{\sigma_x^2 + \sigma_y^2 - \sigma_x \sigma_y + 2 \tau_{xy}^2}$$

- 4 - In a fillet weld, the width of the section considered is the depth of the weld to the bottom of the throat and its length is the effective length of the weld less the end craters.

The length need not be reduced if the joint closes on to itself or if special precautions are taken to limit the effect of the craters.

Attention is drawn to the fact that it seems to be reliably established that fatigue failures in welded joints seldom occur in the weld seam itself but usually beside it in the parent metal.

The stresses σ_{min} and σ_{max} for the fatigue strength calculations for the parent metal beside the weld seam, can therefore in general be computed using the classical methods for calculating the strength of materials.

In order to verify the fatigue strength of the weld itself, it is generally held that it suffices to confirm that it is capable of transmitting the same loads as the adjacent parent metal.

This rule is not obligatory however when the parts jointed are generously dimensioned in relation to the forces actually transmitted. When this is the case it suffices to dimension the weld seam in accordance with those forces, with the proviso that a fatigue check should then be performed in accordance with appendix A-3.6.

Whatever the case it is emphasised that the size of a weld should invariably be in proportion to the thickness of the assembled parts.

Special cases

In certain cases of assembly by welding, particularly when there is a transverse load (i.e. perpendicular to the weld seam), the permissible stresses must be reduced (see clause 3.2.2.3.).

APPENDICES A - 3.3. AND A - 3.4.

CHECKING STRUCTURAL MEMBERS SUBJECT TO CRIPPLING AND BUCKLING

The aim of these two appendices is not to adopt any specific stand on the problem but merely to give some general indications and enable reference to be made to existing works.

A number of different methods are at present in use, among which the following are cited :

- 1 - in Germany, DIN 4114
- 2 - in Belgium, regulation NBN 1
- 3 - in France, the CM 1966 Rules
- 4 - in the United Kingdom, BS 2573. BS 447

APPENDIX A - 3.3.

CHECKING STRUCTURAL MEMBERS SUBJECT TO CRIPPLING

While not wishing to adopt any particular standpoint on this problem, the FEM recommends the use of a practical method in the simpler cases, consisting in amplifying the calculated stress in the various loading cases defined in clauses 2.3.1., 2.3.2., and 2.3.3., by a crippling coefficient ω , dependent upon the slenderness ratio of the member, and checking that, in each of these cases, the stress thus augmented remains less than the stresses given in table T.3.2.1.1.

The values of ω are given in the tables below for the following cases, as a function of the slenderness ratio λ :

Table T.A. 3.3.1. : rolled sections in St 37 steel (Fe 360)

Table T.A. 3.3.2. : rolled sections in St 52 steel (Fe 510)

Table T.A. 3.3.3. : tubes in St 37 steel (Fe 360)

Table T.A. 3.3.4. : tubes in St 52 steel (Fe 510)

Determination of effective lengths for calculating the slenderness ratio λ

- 1 - In the ordinary case of bars hinged at both ends and loaded axially, the effective length is taken as the length between points of articulation.
- 2 - For an axially loaded bar encastered at one end and free at the other the effective length is taken as twice the length of the bar.

- 3 - Because of the uncertainty which exists at present about the effect of fixity on bars in compression between two connections, the effects of fixity are not taken into consideration and the bar is designed as if it were hinged at both ends, the effective length therefore being taken as the length between points of intersection of axes.

The case of bars subjected to compression and bending :

In the case of bars loaded eccentrically or loaded axially with a moment causing bending in the bar :

- either check the following two formulae :

$$\frac{F}{S} + \frac{M_f v}{I} \leq \sigma_a$$

and

$$\frac{\omega F}{S} + 0,9 \frac{M_f v}{I} \leq \sigma_a$$

where :

F is the compressive load applied to the bar,

S is the section area of the bar,

M_f is the bending moment at the section considered,

v is the distance of the extreme fibre from the neutral axis,

I is the moment of inertia ;

- or perform the precise calculation in terms of the deformations sustained by the bar under the combined effect of bending and compression, the necessary calculation being effected either by integration or by successive approximations.

Table T.A. 3.3.1.

Value of the coefficient w in terms of the slenderness ratio λ
for rolled sections in St. 37 steel (Fe 360)

λ	0	1	2	3	4	5	6	7	8	9
20	1.04	1.04	1.04	1.05	1.05	1.06	1.06	1.07	1.07	1.08
30	1.08	1.09	1.09	1.10	1.10	1.11	1.11	1.12	1.13	1.13
40	1.14	1.14	1.15	1.16	1.16	1.17	1.18	1.19	1.19	1.20
50	1.21	1.22	1.23	1.23	1.24	1.25	1.26	1.27	1.28	1.29
60	1.30	1.31	1.32	1.33	1.34	1.35	1.36	1.37	1.39	1.40
70	1.41	1.42	1.44	1.45	1.46	1.48	1.49	1.50	1.52	1.53
80	1.55	1.56	1.58	1.59	1.61	1.62	1.64	1.66	1.68	1.69
90	1.71	1.73	1.74	1.76	1.78	1.80	1.82	1.84	1.86	1.88
100	1.90	1.92	1.94	1.96	1.98	2.00	2.02	2.05	2.07	2.09
110	2.11	2.14	2.16	2.18	2.21	2.23	2.27	2.31	2.35	2.39
120	2.43	2.47	2.51	2.55	2.60	2.64	2.68	2.72	2.77	2.81
130	2.85	2.90	2.94	2.99	3.03	3.08	3.12	3.17	3.22	3.26
140	3.31	3.36	3.41	3.45	3.50	3.55	3.60	3.65	3.70	3.75
150	3.80	3.85	3.90	3.95	4.00	4.06	4.11	4.16	4.22	4.27
160	4.32	4.38	4.43	4.49	4.54	4.60	4.65	4.71	4.77	4.82
170	4.88	4.94	5.00	5.05	5.11	5.17	5.23	5.29	5.35	5.41
180	5.47	5.53	5.59	5.66	5.72	5.78	5.84	5.91	5.97	6.03
190	6.10	6.16	6.23	6.29	6.36	6.42	6.49	6.55	6.62	6.69
200	6.75	6.82	6.89	6.96	7.03	7.10	7.17	7.24	7.31	7.38
210	7.45	7.52	7.59	7.66	7.73	7.81	7.88	7.95	8.03	8.10
220	8.17	8.25	8.32	8.40	8.47	8.55	8.63	8.70	8.78	8.86
230	8.93	9.01	9.09	9.17	9.25	9.33	9.41	9.49	9.57	9.65
240	9.73	9.81	9.89	9.97	10.05	10.14	10.22	10.30	10.39	10.47
250	10.55									

Table T.A. 3.3.2.

Value of the coefficient ω in terms of the slenderness ratio λ
for rolled sections in St 52 steel (Fe 510)

λ	0	1	2	3	4	5	6	7	8	9
20	1.06	1.06	1.07	1.07	1.08	1.08	1.09	1.09	1.10	1.11
30	1.11	1.12	1.12	1.13	1.14	1.15	1.15	1.16	1.17	1.18
40	1.19	1.19	1.20	1.21	1.22	1.23	1.24	1.25	1.26	1.27
50	1.28	1.30	1.31	1.32	1.33	1.35	1.36	1.37	1.39	1.40
60	1.41	1.43	1.44	1.46	1.48	1.49	1.51	1.53	1.54	1.56
70	1.58	1.60	1.62	1.64	1.66	1.68	1.70	1.72	1.74	1.77
80	1.79	1.81	1.83	1.86	1.88	1.91	1.93	1.95	1.98	2.01
90	2.05	2.10	2.14	2.19	2.24	2.29	2.33	2.38	2.43	2.48
100	2.53	2.58	2.64	2.69	2.74	2.79	2.85	2.90	2.95	3.01
110	3.06	3.12	3.18	3.23	3.29	3.35	3.41	3.47	3.53	3.59
120	3.65	3.71	3.77	3.83	3.89	3.96	4.02	4.09	4.15	4.22
130	4.28	4.35	4.41	4.48	4.55	4.62	4.69	4.75	4.82	4.89
140	4.96	5.04	5.11	5.18	5.25	5.33	5.40	5.47	5.55	5.62
150	5.70	5.78	5.85	5.93	6.01	6.09	6.16	6.24	6.32	6.40
160	6.48	6.57	6.65	6.73	6.81	6.90	6.98	7.06	7.15	7.23
170	7.32	7.41	7.49	7.58	7.67	7.76	7.85	7.94	8.03	8.12
180	8.21	8.30	8.39	8.48	8.58	8.67	8.76	8.86	8.95	9.05
190	9.14	9.24	9.34	9.44	9.53	9.63	9.73	9.83	9.93	10.03
200	10.13	10.23	10.34	10.44	10.54	10.65	10.75	10.85	10.96	11.06
210	11.17	11.28	11.38	11.49	11.60	11.71	11.82	11.93	12.04	12.15
220	12.26	12.37	12.48	12.60	12.71	12.82	12.94	13.05	13.17	13.28
230	13.40	13.52	13.63	13.75	13.87	13.99	14.11	14.23	14.35	14.47
240	14.59	14.71	14.83	14.96	15.08	15.20	15.33	15.45	15.58	15.71
250	15.83									

Table T.A. 3.3.3.

Value of the coefficient ω in terms of the slenderness ratio λ
for tubes in St 37 steel (Fe 360)

λ	0	1	2	3	4	5	6	7	8	9
20	1.00	1.00	1.00	1.00	1.01	1.01	1.01	1.02	1.02	1.02
30	1.03	1.03	1.04	1.04	1.04	1.05	1.05	1.05	1.06	1.06
40	1.07	1.07	1.08	1.08	1.09	1.09	1.10	1.10	1.11	1.11
50	1.12	1.13	1.13	1.14	1.15	1.15	1.16	1.17	1.17	1.18
60	1.19	1.20	1.20	1.21	1.22	1.23	1.24	1.25	1.26	1.27
70	1.28	1.29	1.30	1.31	1.32	1.33	1.34	1.35	1.36	1.37
80	1.39	1.40	1.41	1.42	1.44	1.46	1.47	1.48	1.50	1.51
90	1.53	1.54	1.56	1.58	1.59	1.61	1.63	1.64	1.66	1.68
100	1.70	1.73	1.76	1.79	1.83	1.87	1.90	1.94	1.97	2.01
110	2.05	2.08	2.12	2.16	2.20	2.23				
For $\lambda > 115$, take the values of ω from table T.A. 3.3.1.										

Table T.A. 3.3.4.

Value of the coefficient ω in terms of the slenderness ratio λ
for tubes in St 52 steel (Fe 510)

λ	0	1	2	3	4	5	6	7	8	9
20	1.02	1.02	1.02	1.03	1.03	1.03	1.04	1.04	1.05	1.05
30	1.05	1.06	1.06	1.07	1.07	1.08	1.08	1.09	1.10	1.10
40	1.11	1.11	1.12	1.13	1.13	1.14	1.15	1.16	1.16	1.17
50	1.18	1.19	1.20	1.21	1.22	1.23	1.24	1.25	1.26	1.27
60	1.28	1.30	1.31	1.32	1.33	1.35	1.36	1.38	1.39	1.41
70	1.42	1.44	1.46	1.47	1.49	1.51	1.53	1.55	1.57	1.59
80	1.62	1.66	1.71	1.75	1.79	1.83	1.88	1.92	1.97	2.01
90	2.05									

For $\lambda > 90$, take the values of ω from table T.A. 3.3.2.

Note : The values of ω in table T.A. 3.3.3. and T.A. 3.3.4. are valid for calculating the case of an axially loaded bar consisting of a single tube whose diameter is equal to at least six times its thickness.

APPENDIX A - 3.4.

CHECKING STRUCTURAL MEMBERS SUBJECT TO BUCKLING

From the theoretical standpoint, the critical buckling stress σ_{Cr}^y is regarded as a multiple of the EULER Stress given by the formula :

$$\sigma_R^E = \frac{-^2 E}{12 (1 - \eta^2)} \cdot \left(\frac{e}{b} \right)^2$$

representing the critical buckling stress for a strip of thickness e , having a width equal to b , this being the plate dimension measured in the direction perpendicular to the compression forces (see sketch below).

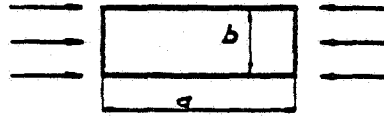

In this formula, E is the modulus of elasticity and η Poisson's Ratio.

For normal steels in which $E = 210\ 000\ \text{N/mm}^2$ and $\eta = 0,3$, the EULER Stress becomes :

$$\sigma_R^E = 189\ 800 \left(\frac{e}{b} \right)^2$$

The critical buckling stress σ_{Cr}^y must be a multiple of this value, whence :

$$\sigma_{Cr}^y = K_\sigma \sigma_R^E$$

in the case of compression.

In the case of shear the critical stress is :

$$\tau_{Cr}^y = K_\tau \sigma_R^E$$

The coefficients K_σ and K_τ , known as the buckling coefficients, depend on :

- the ratio $\alpha = \frac{a}{b}$ of the two sides of the plate
- the manner in which the plate is supported along the edges
- the type of loading sustained by the plate in its own plane
- any reinforcement of the plate by stiffeners.

Value of coefficients K_σ and K_τ

Without wishing to enter into the details of this problem, which is the subject of specialised works and of particular standards, we give hereafter values of K_σ and K_τ for a few simple cases (see table T.A. 3.4.1.).

For more complex cases, reference should be made to specialised literature.

Combined compression and shear

Taking σ and τ to be calculated stresses in compression and in shear the critical comparison stress $\sigma_{Cr.c}^v$ is determined from the expression :

$$\sigma_{Cr.c}^v = \frac{\sqrt{\sigma^2 + 3\tau^2}}{\frac{1+\psi}{4} \cdot \frac{\sigma}{\sigma_{Cr}^v} + \sqrt{\left(\frac{3-\psi}{4} \cdot \frac{\sigma}{\sigma_{Cr}^v}\right)^2 + \left(\frac{\tau}{\tau_{Cr}^v}\right)^2}}$$

ψ being defined in the table T.A. 3.4.1.

Important note : It is essential to note that the formulae above giving the critical stresses σ_{Cr}^v and $\sigma_{Cr.c}^v$ apply only when the values determined thus are below the limit of proportionality (i.e. 190 N/mm² for A.37 steel, 290 N/mm² for A.52 steel).

Similarly, the formula giving τ_{Cr}^v applies only when the value $\sqrt{3} \tau_{Cr}^v$ is below the limit of proportionality.

Whenever the formulae give values above these limits, it is necessary to adopt a limiting critical value, obtained by multiplying the calculated critical value by the coefficient ρ given in the table T.A. 3.4.2., which also indicates the reduced values corresponding to various calculated values of σ_{Cr}^v and τ_{Cr}^v .

Table T.A. 3.4.1.

Value of the buckling coefficients K_{σ} and K_{τ} for plates supported at their four edges

No.	CASE	$\alpha = \frac{a}{b}$	K_{σ} or K_{τ}
1	Simple uniform compression 	$\alpha \geq 1$ $\alpha \leq 1$	$K_{\sigma} = 4$ $K_{\sigma} = (\alpha + \frac{1}{\alpha})^2$
2	Non-uniform compression 	$\alpha \geq 1$ $\alpha \leq 1$	$K_{\sigma} = \frac{8,4}{\Psi + 1,1}$ $K_{\sigma} = (\alpha + \frac{1}{\alpha})^2 \cdot \frac{2,1}{\Psi + 1,1}$
3	Pure bending $\Psi = -1$ or bending with tension preponderant 	$\alpha \geq \frac{2}{3}$ $\alpha \leq \frac{2}{3}$	$K_{\sigma} = 23,9$ $K_{\sigma} = 15,87 + \frac{1,87}{\alpha^2} + 8,6 \alpha^2$
4	Bending with compression preponderant $-1 < \Psi < 0$ 		$K_{\sigma} = (1 + \Psi) K' - \Psi K'' + 10 \Psi (1 + \Psi)$ where: $K' =$ value of K_{σ} for $\Psi = 0$ in case no. 2 $K'' =$ value of K_{σ} for pure bending (case no. 3)
5	Pure shear 	$\alpha \geq 1$ $\alpha \leq 1$	$K_{\tau} = 5,34 + \frac{4}{\alpha^2}$ $K_{\tau} = 4 + \frac{5,34}{\alpha^2}$

Table T.A. 3.4.2.

Values of ρ and the reduced critical stresses

$\sigma_{cr}^v, \sigma_{cr.c}^v$ and T_{cr}^v (N/mm²)

σ_{cr}^v or $\sigma_{cr.c}^v$ calculated	T_{cr}^v calculated	ρ	σ_{cr}^v or $\sigma_{cr.c}^v$ reduced	T_{cr}^v reduced	σ_{cr}^v or $\sigma_{cr.c}^v$ calculated	T_{cr}^v calculated	ρ	σ_{cr}^v or $\sigma_{cr.c}^v$ reduced	T_{cr}^v reduced
Steel St 37 (Fe 360)					Steel St 52 (Fe 510)				
190	110	1,00	190	110	290	168	1,00	290	168
200	116	0,97	194	113	300	173	0,98	294	169
210	121	0,94	197	114	310	179	0,96	297	172
220	127	0,91	200	116	320	185	0,94	300	174
230	133	0,88	202	117	330	191	0,92	303	175
240	139	0,85	204	118	340	196	0,90	306	176
250	145	0,82	206	119	350	202	0,88	309	177
260	150	0,80	208	120	360	208	0,86	309	178
280	162	0,76	212	122	380	220	0,82	312	180
300	173	0,72	215	124	400	231	0,79	316	182
340	197	0,65	221	128	440	254	0,73	322	185

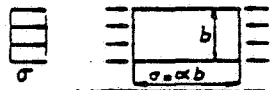
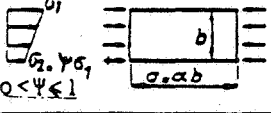
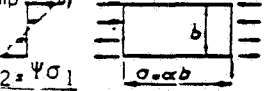
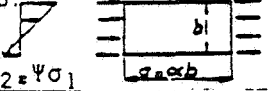
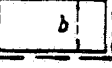
Determination of permissible buckling stresses

After the critical buckling stresses have been determined as indicated above, the permissible stress is obtained by dividing the critical stress by the coefficient ψ determined in clause 3.4.

The calculations are then performed as follows :

The stresses are determined for each case of loading, in accordance with clause 3.4., after which a check is made to ensure that these calculated stresses do not exceed the permissible stresses determined as indicated above.

Note : In the case of combined compression and shear, the critical comparison stress $\sigma_{cr,c}$ must be compared with the comparison stress calculated from the formula in clause 3.2.1.3. :

$$\sigma_{cp} = \sqrt{\sigma^2 + 3 \tau^2}$$

Example of checking for buckling

Take the case of a plate girder in St 37 steel, having a span of 10 m, a depth of 1,50 m, a web thickness of 0,010 m, a uniformly distributed load of 162 kN/m and stiffeners 1,25 m apart.

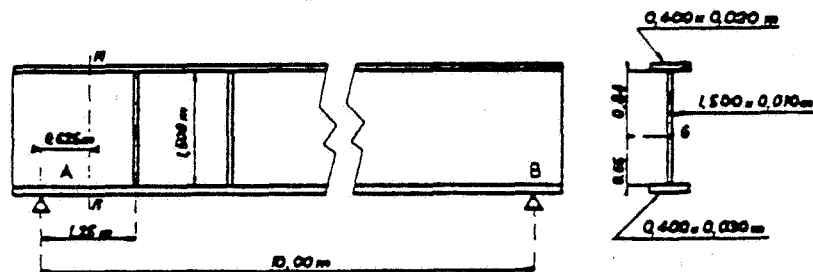

Reactions on supports : $A = B = 810 \text{ kN}$

Moment of inertia of the beam = $1\,419\,000 \text{ cm}^4$

Checking at section MN, located 0,625 m from A

Bending moment at MN :

$$M_f = 810 \times 0,625 - \frac{162 \times 0,625^2}{2} = 474,7 \text{ kNm}$$

Upper stress (compression) :

$$\sigma_1 = - \frac{474,7 \times 10^6 \times 0,84 \times 10^3}{1\,419\,000 \times 10^8} = - 28 \text{ N/mm}^2$$

Lower stress (tension) :

$$\sigma_2 = \frac{474,7 \times 10^6 \times 0,66 \times 10^3}{1\,419\,000 \times 10^8} = 22 \text{ N/mm}^2$$

These stresses are calculated at the upper and lower edges of the web.

shear stress :

$$\frac{810 \times 10^3 - 162 \times 0,625 \times 10^3}{10 \times 1500} = 47 \text{ N/mm}^2$$

Bending : (case 4 - compression preponderant) :

$$\Psi = \frac{0,22}{-0,28} = -0,79 \quad \alpha = \frac{1,25}{1,50} = 0,83 (< 1)$$

giving $K_G = (1 + \Psi)K' - \Psi K'' + 10 \Psi (1 + \Psi)$

$$\text{in which } K' = \left(\alpha + \frac{1}{\alpha}\right)^2 \times \frac{2,1}{0 + 1,1} = \left(0,83 + \frac{1}{0,83}\right)^2 \times \frac{2,1}{1,1} = 7,90$$

and $K'' = 23,9$

$$\text{whence } K_G = (1 - 0,79) 7,90 + 0,79 \times 23,9 - 10 \times 0,79 (1 - 0,79) = 18,88$$

The Euler Stress :

$$\sigma_R^E = 189\,800 \left(\frac{e}{b}\right)^2 = 189\,800 \left(\frac{10}{1500}\right)^2 = 8,4 \text{ N/mm}^2$$

giving a critical buckling stress :

$$\sigma_{Cr}^V = K_G \cdot \sigma_R^E = 18,88 \times 8,4 = 258,6 \text{ N/mm}^2$$

Shear :

$$K_T = 4 + \frac{5,34}{\alpha^2} = 4 + \frac{5,34}{0,83^2} = 11,75$$

and

$$\tau_{Cr}^V = K_T \sigma_R^E = 11,75 \times 8,4 = 99 \text{ N/mm}^2$$

The critical comparison stress then becomes :

$$\sigma_{Cr.c}^V = \frac{\sqrt{28^2 + 3 \times 47^2}}{\frac{1 - 0,79}{4} \times \frac{28}{158,5} + \sqrt{\left(\frac{3 + 0,79}{4} \times \frac{28}{158,5}\right)^2 + \left(\frac{47}{99}\right)^2}} = 168 \text{ N/mm}^2$$

Conclusion :

The comparison stress in the case of tension (or compression) combined with shear is given in clause 3.2.1.3.

$\sqrt{\sigma^2 + 3 \tau^2} = 86 \text{ N/mm}^2$. This value is smaller than the critical buckling stress given in 3.4. (with $\nu_y = 1,4$) $\frac{168}{1,4} = 120 \text{ N/mm}^2$ for loading case I.

The permissible buckling stress is therefore not exceeded in loading case I.

Naturally, a check must also be made to ensure that the permissible buckling stresses are not exceeded in loading cases II and III.

Checking of buckling for circular cylinders :

Thin wall circular cylinders such as, for example, large tubes, which are subject to central or eccentric axial compression have to be checked for local buckling if :

$$\frac{t}{r} \leq \frac{25 \cdot \sigma_E}{E}$$

where :

t = thickness of the wall ;

r = radius from the middle of the wall thickness ;

σ_E = elastic limit of the steel type, as in table T. 3.2.1.1.

E = modulus of elasticity, see A-3.4.

The ideal buckling stress σ_1^Y can be determined from :

$$\sigma_1^Y = 0,2 \frac{E \cdot t}{r}$$

In all cases where σ_1^Y is situated above the limit of proportionality of the structural steel, the ideal buckling stress σ_1^Y has to be reduced to σ^Y by means of the factor ρ .

At a maximum spacing of $10r$, transverse stiffeners have to be provided whose moment of inertia has to be at least :

$$I = \frac{r \cdot t^3}{2} \sqrt{\frac{r}{t}}$$

The moment of inertia is calculated from the following formulae :

1 - Central disposition of the stiffener F (centre of gravity of the stiffener section in the median plane of the wall thickness).

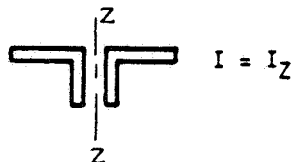

2 - Eccentric disposition of the stiffener F (centre of gravity of the stiffener section F_2 outside the median plane of the wall 1).

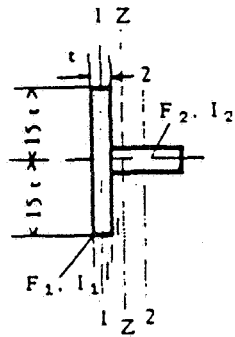

$$I = I_1 + I_2 + F_1 \cdot e_1^2 + F_2 \cdot e_2^2$$

It is accepted that this calculation of σ_1^y and σ^y respectively takes account of geometrical divergences between the real and the ideal cylinder surfaces due to local construction defects up to a dimension of $\frac{t}{2}$.

APPENDIX A - 3.6.

CHECKING STRUCTURAL MEMBERS SUBJECT TO FATIGUE

It must be remembered that fatigue is one of the causes of failure envisaged in clause 3.6. and therefore checking for fatigue is additional to checking in relation to the elastic limit of permissible crippling or buckling.

If the permissible stresses for fatigue, as determined hereunder, are higher than those allowed for other conditions then this merely indicates that the dimensions of the components are not determined by considerations of fatigue.

Clause 3.6. enumerates the parameters which must be considered when checking structural components for fatigue.

The purpose of this appendix is firstly to classify the various joints according to their notch effect, as defined in clause 3.6.2. and, then, to determine for these various notch effects and for each classification group of the component as defined in clause 2.1.4. the permissible stresses for fatigue as a function of the coefficient k defined in clause 3.6.4.

These permissible fatigue stresses were determined as a result of tests carried out by the F.E.M. on test pieces having different notch effects and submitted to various loading spectra. They were determined on the basis of the stress values which, in the tests, assured 90 % survival including a factor of safety of 4/3.

In practice, a structure consists of members which are welded, riveted or bolted together and experience shows that the behaviour of a member differs greatly from one point to another ; the immediate proximity of a joint invariably constitutes a weakness that will be vulnerable to a varying extent according to the method of assembly used.

An examination is therefore made in the first sections, of the effect of fatigue on structural members both away from any joint and in immediate proximity to the usual types of joint.

The second section examines the resistance to fatigue of the means of assembly themselves, i.e. weld seams, rivets and bolts.

1 - VERIFICATION OF STRUCTURAL MEMBERS

The starting point is the fatigue strength of the continuous metal away from any joint and, in general, away from any point at which a stress concentration, and hence a lessening of the fatigue strength, may occur.

In order to make allowance for the reduction in strength near joints, as a result of the presence of holes or welds producing changes of section, the notch effects in the vicinity of these joints, which characterize the effects of the stress concentrations caused by the presence of discontinuities in the metal, are examined.

These notch effects bring about a reduction of the permissible stresses, the extent of which depends upon the type of discontinuity encountered, i.e. upon the method of assembly used.

In order to classify the importance of these notch effects, the various forms of joint construction are divided into categories as follows :

Unwelded parts

These members present three cases of construction.

Case W_0 concerns the material itself without notch effect.

Cases W_1 and W_2 concern perforated members (see table T.A.3.6.(1))

Welded parts

These joints are arranged in order of the severity of the notch effect increasing from K_0 to K_4 , corresponding to structural parts located close to the weld fillets.

The table T.A. 3.6. (1) gives some indications as to the quality of the welding and a classification of the welding and of the various joints that are most often used in the construction of lifting appliances.

Determination of the permissible stresses for fatigue

Tensile and compressive loads

The basis values which have been used to determine the permissible stresses in tension and compression are those resulting from the application of a constant alternating stress $\pm \sigma_w$ ($\kappa = -1$) giving a survival rate of 90 % in the tests, to which a factor of safety of 4/3 has been applied.

To take account of the number of cycles and of the stress spectrum, the σ_w values have been set for each classification group of the member the latter taking account of these two parameters.

For unwelded parts, the values σ_w are identical for steel St 37, and St 44. They are higher for St 52.

For welded parts, the σ_w values are identical for the three types of steel.

Table T.A. 3.6.1.

Values of σ_w depending on the component
group and construction case (N/mm²)

Component group	Unwelded components Construction cases						Welded components Construction cases (Steels St 37 to St 52, Fe 360 to Fe 510)				
	W ₀		W ₁		W ₂		K ₀	K ₁	K ₂	K ₃	K ₄
	Fe 360 St 37 St 44	St 52 Fe 510	Fe 360 St 37 St 44	St 52 Fe 510	Fe 360 St 37 St 44	St 52 Fe 510					
E1	249,1	298,0	211,7	253,3	174,4	208,6	(361,9)	(323,1)	(271,4)	193,9	116,3
E2	224,4	261,7	190,7	222,4	157,1	183,2	(293,8)	262,3	220,3	157,4	94,4
E3	202,2	229,8	171,8	195,3	141,5	160,8	238,4	212,9	178,8	127,7	76,6
E4	182,1	201,8	154,8	171,5	127,5	141,2	193,5	172,8	145,1	103,7	62,2
E5	164,1	177,2	139,5	150,6	114,9	124,0	157,1	140,3	117,8	84,2	50,5
E6	147,8	155,6	125,7	132,3	103,5	108,9	127,5	113,8	95,6	68,3	41,0
E7	133,2	136,6	113,2	116,2	93,2	95,7	103,5	92,4	77,6	55,4	33,3
E8	120,0	120,0	102,0	102,0	84,0	84,0	84,0	75,0	63,0	45,0	27,0

The values in brackets are greater than 0,75 times the breaking stress and are only theoretical values (see note 2 at the end of this clause).

The following formulae give for all values of κ the permissible stresses for fatigue :

a) $\kappa < 0$

$$\text{- for tension : } \sigma_t = \sigma_w \frac{5}{3 - 2\kappa} \quad (1)$$

$$\text{- for compression : } \sigma_c = \sigma_w \frac{2}{1 - \kappa} \quad (2)$$

σ_w is given in table above.

b) $\kappa > 0$

- for tension
$$\sigma_t = \frac{\sigma_0}{1 - (1 - \frac{\sigma_0}{\sigma_{+1}}) \kappa} \quad (3)$$

- for compression
$$\sigma_c = 1,2 \sigma_t \quad (4)$$

where σ_0 = tensile stress for $\kappa = 0$ is given by the formula (1) that is :

$$\sigma_0 = 1,66 \sigma_w$$

σ_{+1} = tensile stress for $\kappa = +1$ that is the ultimate strength σ_R divided by the coefficient of safety 4/3 :

$$\sigma_{+1} = 0,75 \sigma_R$$

σ_t is limited in every case to $0,75 \sigma_R$.

By way of illustration, fig. A.3.6.1. shows curves giving the permissible stress as a function of the ratio κ for the following cases :

- steel A.52 ;
- predominant tensile stress ;
- groupe E6 ;
- construction cases W_0, W_1, W_2 for unwelded components and cases of construction for joints K_0 to K_4 .

The permissible stresses have been limited to 240 N/mm^2 , i.e. to the permissible stress adopted for checking for ultimate strength.

Figure A.3.6.1.

(A 52; tension; group E6)

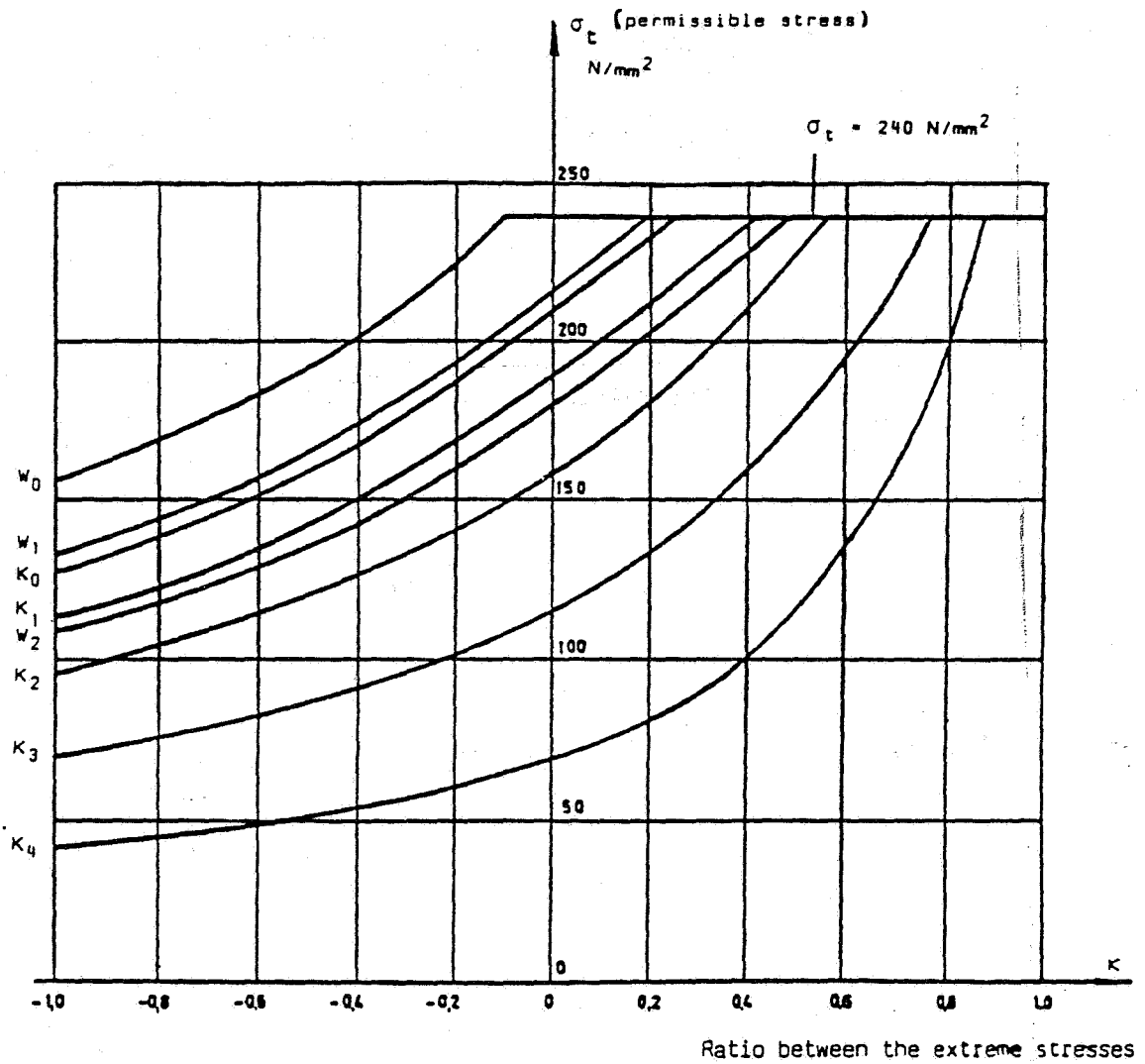

Shear stresses in the material of structural parts

For each of the groups from E1 to E8 the permissible fatigue stress in tension of the case W_0 divided by $\sqrt{3}$ is taken :

$$\tau_a = \frac{\sigma_t \text{ of case } W_0}{\sqrt{3}}$$

Combined loads in tension (or compression) and shear

In this case the permissible stresses for fatigue for each normal load in tension (or compression) σ_{xa} and σ_{ya} and shear τ_{xya} are determined by assuming that each acts separately taking respectively the following values of κ in accordance with clause 3.6.4. :

$$\kappa_x = \frac{\sigma_x \text{ min}}{\sigma_x \text{ max}} \quad ; \quad \kappa_y = \frac{\sigma_y \text{ min}}{\sigma_y \text{ max}} \quad \text{and} \quad \kappa_{xy} = \frac{\tau_{xy} \text{ min}}{\tau_{xy} \text{ max}}$$

Then the following three conditions are checked :

$$\sigma_x \text{ max} < \sigma_{xa} \quad ; \quad \sigma_y \text{ max} < \sigma_{ya} \quad \text{and} \quad \tau_{xy} \text{ max} < \tau_{xya}$$

None of the calculated shears should exceed the permissible value of σ_a in case I loading (see table T.3.2.1.1.).

- a) If any one stress is markedly greater than the other two in any given case of loading, it will suffice to check the member for fatigue under the corresponding load, neglecting the effect of the other two.

- b) In the other cases, in addition to checking for each loading assumed to act alone, it is recommended that the following relationship be checked :

$$\left(\frac{\sigma_x \max}{\sigma_{xa}}\right)^2 + \left(\frac{\sigma_y \max}{\sigma_{ya}}\right)^2 - \frac{\sigma_x \max \sigma_y \max}{|\sigma_{xa}| |\sigma_{ya}|} + \left(\frac{\tau_{xy \max}}{\tau_{xya}}\right)^2 \leq 1 \quad (1) \quad (5)$$

where the stress values σ_{xa} , σ_{ya} and τ_{xya} are those resulting from the application of formulae (1), (2), (3) and (4) limited to $0,75 \sigma_R$.

In applying this formula, reference should be made to the directions given in clause 3.2.1.3. In other words :

- either perform the check by combining the maximum values $\sigma_x \max$, $\sigma_y \max$ and $\tau_{xy \max}$, and comparing with the permissible stresses σ_{xa} , σ_{ya} and τ_{xya} computed on the basis of the most unfavourable values of κ .
- or seek the most unfavourable combination actually possible by making the check with the following values :
 - a) $\sigma_x \max$ and $\kappa_x \min$ with the corresponding values of σ_y , τ_{xy} , κ_y and κ_{xy}
 - b) $\sigma_y \max$ and $\kappa_y \min$ with the corresponding values of σ_x , τ_{xy} , κ_x and κ_{xy}
 - c) $\tau_{xy \max}$ and $\kappa_{xy \min}$ with the corresponding values of σ_x , σ_y , κ_x and κ_y

In this connection, see note in clause 3.2.1.3.

In order to facilitate the calculations, table T.A. 3.6.2. gives the permissible values of :

$$\frac{\tau_{xy \max}}{\tau_{xya}} \text{ as a function of } \frac{\sigma_x \max}{\sigma_{xa}} \text{ and of } \frac{\sigma_y \max}{\sigma_{ya}}$$

In this table, the values of $\frac{\sigma_x \max}{\sigma_{xa}}$ are given in the left hand column with

the following convention : the ratio is considered to be positive if $\sigma_x \max$ and $\sigma_y \max$ have the same sign, and negative otherwise.

- (1) As this inequality constitutes a severe requirement, values slightly higher than 1 are acceptable, but in this case it is necessary to check the relation :

$$\sqrt{\left(\frac{\sigma_x \max}{\sigma_{xa}}\right)^2 + \left(\frac{\sigma_y \max}{\sigma_{ya}}\right)^2 - \frac{\sigma_x \max \cdot \sigma_y \max}{|\sigma_{xa}| \cdot |\sigma_{ya}|} + \left(\frac{\tau_{xy \max}}{\tau_{xya}}\right)^2} \leq 1,05$$

It should also be noted that the values $|\sigma_{xa}|$ and $|\sigma_{ya}|$ in the denominator for the third term should be taken as absolute values, $\sigma_x \max$ and $\sigma_y \max$ being assigned their algebraic values.

Table T.A. 3.6.2.

Values of $\frac{\tau_{xy \max}}{\tau_{xya}}$ in terms of $\frac{\sigma_x \max}{\sigma_{xa}}$ and $\frac{\sigma_y \max}{\sigma_{ya}}$

$\frac{\sigma_x \max}{\sigma_{xa}}$	$\frac{\sigma_y \max}{\sigma_{ya}}$										
	1,0	0,9	0,8	0,7	0,6	0,5	0,4	0,3	0,2	0,1	0
+ 1,0	0	0,300	0,400	0,458	0,490	0,500	0,490	0,458	0,400	0,300	0
+ 0,9	0,300	0,436	0,520	0,575	0,608	0,625	0,625	0,608	0,575	0,520	0,436
+ 0,8	0,400	0,520	0,600	0,656	0,693	0,714	0,721	0,714	0,693	0,656	0,600
+ 0,7	0,458	0,575	0,656	0,714	0,755	0,781	0,794	0,781	0,781	0,755	0,714
+ 0,6	0,490	0,608	0,693	0,755	0,800	0,831	0,849	0,854	0,849	0,831	0,800
+ 0,5	0,500	0,625	0,714	0,781	0,831	0,866	0,889	0,900	0,900	0,889	0,866
+ 0,4	0,490	0,625	0,721	0,794	0,849	0,889	0,917	0,933	0,938	0,933	0,917
+ 0,3	0,458	0,608	0,714	0,794	0,854	0,900	0,933	0,954	0,964	0,964	0,954
+ 0,2	0,400	0,575	0,693	0,781	0,849	0,900	0,938	0,964	0,980	0,985	0,980
+ 0,1	0,300	0,520	0,656	0,755	0,831	0,889	0,933	0,964	0,985	0,995	0,995
0	0	0,436	0,600	0,714	0,800	0,866	0,916	0,954	0,980	0,995	1,000
- 0,1		0,300	0,520	0,656	0,755	0,831	0,889	0,933	0,964	0,985	0,995
- 0,2			0,400	0,575	0,693	0,781	0,849	0,900	0,938	0,964	0,980
- 0,3			0,173	0,458	0,608	0,714	0,794	0,854	0,900	0,933	0,954
- 0,4				0,265	0,490	0,625	0,721	0,781	0,849	0,889	0,917
- 0,5					0,300	0,500	0,625	0,714	0,781	0,831	0,866
- 0,6						0,300	0,490	0,608	0,693	0,755	0,800
- 0,7							0,265	0,458	0,575	0,656	0,714
- 0,8								0,173	0,400	0,520	0,600
- 0,9										0,300	0,436
- 1,0											0

If $\sigma_x \max$ and $\sigma_y \max$ are of opposite sign (tension or compression) read the values of $\frac{\tau_{xy \max}}{\tau_{xya}}$ starting from the negative values of $\frac{\sigma_x \max}{\sigma_{xa}}$

General notes

Note 1 - In applying the above considerations, it is essential to take into account the secondary bending effects which a particular method of assembly may cause in the members of the structure.

Note 2 - If reference is made to the table of values of σ_w it can be seen that in groups E1 and E2 much higher stresses than those usually permitted in structures are quoted. These values are in fact only theoretical values obtained by extrapolation of the test results on higher groups (E3 to E8) with medium or severe notch cases (K_2 , K_3 and K_4). Therefore there is no need to attach any material significance to these values in brackets, consideration of which could in some cases lead to the conclusion that an assembly of type K_0 or K_1 could resist fatigue better than the unwelded metal (case W_0). This apparent anomaly illustrates the well known fact that it is not always necessary to carry out fatigue checks for the lower groups with slight or moderate notch cases.

With respect to the calculations it must be remembered that these theoretical σ_w values are used only to determine the permissible fatigue stresses σ_{xa} , σ_{ya} and τ_{xya} for use in formula (5) which covers the case of combined loads.

Examples of calculations are given at the end of the Appendix.

2 - VERIFICATION OF THE JOINING MEANS (welds, bolts, rivets)

Welds

a) Tensile and compressive loads in the welds :

Welds subjected to fatigue under tensile and compressive loads are checked using the same permissible stresses as those of the metal joined.

Note - The limits indicated under 3.2.2.3. for certain particular cases of transverse tension and compression in weld seams must be observed.

Appendix A-3.2.2.3. gives, in addition, some indications for the determination of the stresses in the weld seams.

b) Shear loads in the welds :

The permissible shear fatigue stresses in the welds are determined by dividing the permissible stresses in tension for case K_0 by $\sqrt{2}$.

c) Combined loads :

The method set out above for structural members is used when considering the effect of fatigue in weld seams subjected to variable combined loads.

Bolts and rivets

a) Tensile loads :

Fatigue due to variable tensile loads in bolts and rivets need not be considered.

In this connection, it should be noted that bolts and, even more important, rivets working in tension should be avoided as far as possible.

b) Shear loads and bearing pressure :

Single and multiple shear loads as defined under 3.2.2.1.1. must be distinguished.

The permissible shear stresses for fatigue for bolts and rivets are fixed by multiplying the permissible stresses in tension for case W_2 by :

0,6 for single shear

0,8 for multiple shear

The permissible bearing pressure values are obtained by multiplying the permissible shear values in the bolts and rivets by 2,5.

Table T.A. 3.6.(1)







Classification of cases of construction for joints

Joints may be riveted, bolted or welded.

The types of weld most commonly used for hoisting appliances are butt welds, double bevel butt welds (K welds) and fillet welds, of ordinary quality (O.Q.) or special quality (S.Q.) as specified below.

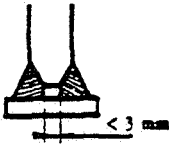
Weld testing is also stipulated for certain types of joint.

A - Weld qualities

Type of weld	Weld quality	Execution of weld	Symbol ⁽¹⁾	Weld testing	Symbol
Full depth butt weld	Special quality (S.Q.)	Root of weld scraped (or trimmed) before making sealing run. No end craters. Weld ground flush with plate parallel to direction of forces		Check (e.g. with X-rays) over 100 % of seam length	P 100
	Ordinary quality (O.Q.)	Root of weld scraped (or trimmed) before making sealing run. No end craters		If the calculated stress > 80 % times the permissible stress	P 100
				Otherwise random check over at least 10 % of seam length	P 10
K-weld in angle formed by two parts with bevel on one of the parts to be joined at location of seam	Special quality (S.Q.)	Root of weld scraped (or trimmed) before making weld on other side. Weld edges without under-cutting and ground if necessary. Full penetration welds		Check that for tensile loads the plate perpendicular to the direction of the forces is free from lamination.	D
	Ordinary quality (O.Q.)	width clear of weld penetration between the two welds < 3 mm 			
Fillet welds in the angle formed by two parts	Special quality (S.Q.)	Welded edges without undercutting and ground if necessary		Check that for tensile loads the plate perpendicular to the direction of the forces is free from lamination	D
	Ordinary quality (O.Q.)				

(1) See page 3-59

Table T.A. 3.6.(1) (cont'd)

B - Cases of construction for joints

In the tables below the various cases of means of assembly are classified in terms of the magnitude of the notch effect they produce.

It should be noted that, with a given weld, the notch effect differs according to the type of loading to which the joint is subjected.

For example, a fillet welded joint is classified under case K_0 for longitudinal tension or compression loads (0,31) or longitudinal shear (0,51), and under cases K_3 or K_4 for transverse tension or compression loads (3,2 or 4,4).

1 - Non welded parts

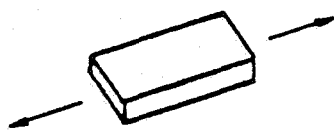

Case W_0

Reference	Description	Figure	Symbol
W_0	Parent metal, homogeneous surface. Part without joints or breaks in continuity (solid bars) and without notch effects unless the latter can be calculated.		

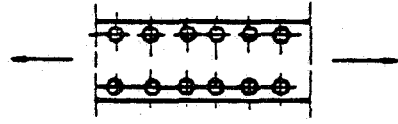
Case W_1



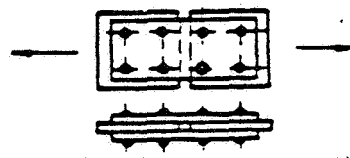

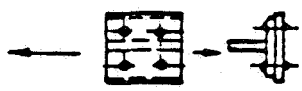
Reference	Description	Figure	Symbol
W_1	Parts drilled. Parts drilled for riveting or bolting with rivets and bolts loaded up to 20 % of permissible values. Parts drilled for joints using high strength bolts (Cl 3.2.2.2.2.3.) loaded up to 100 % of permissible values (Cl 3.2.2.2.2.2.)		

Case W_2

Reference	Description	Figure	Symbol
$W_{2.1}$	Parts drilled for riveting or bolting in which the rivets or bolts are loaded in multiple shear		
$W_{2.2}$	Parts drilled for riveting or bolting, in which the rivets or bolts are loaded in single shear (allowing for eccentric loads), the parts being unsupported		
$W_{2.3}$	Parts drilled for assembling by means of rivets or bolts loaded in single shear, the parts being supported or guided		

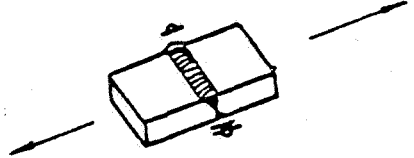
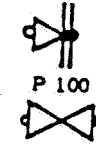
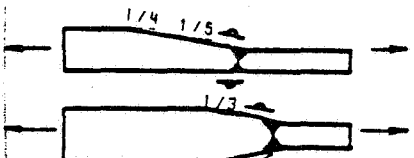
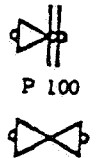
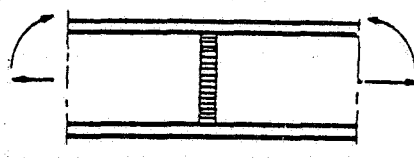
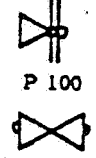
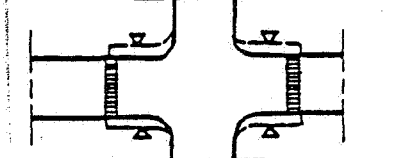
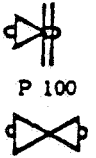
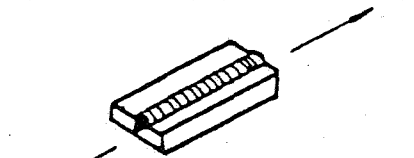
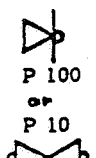
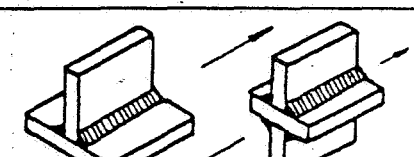

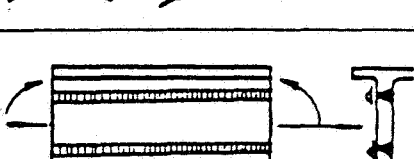
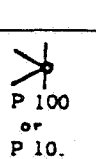
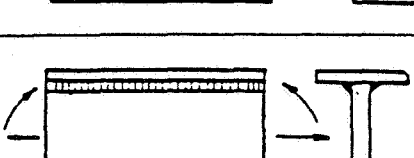
2 - Welded parts

Case K_0 - Slight stress concentration

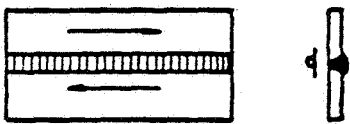
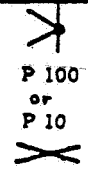

Reference	Description	Figure	Symbol (1)
0,1	Parts butt-welded (S.Q.) at right angles to direction of forces		 P 100
0,11	Parts of different thickness butt-welded (S.Q.) at right angles to direction of forces. Asymmetrical slope : 1/4 to 1/5; Symmetrical slope : 1/3		 P 100
0,12	Butt weld (S.Q.) in transverse joint of web plate		 P 100
0,13	Gusset secured by butt-welding (S.Q.) at right angles to the direction of the forces		 P 100
0,3	Parts joined by butt-welding (O.Q.) parallel to the direction of the forces		 P 100 or P 10
0,31	Parts joined by fillet welds (O.Q.) parallel to the direction of the forces (longitudinal to the joined parts)		
0,32	Butt weld (O.Q.) between section forming flange and web of a beam		 P 100 or P 10.
0,33	K- or fillet weld (O.Q.) between flange and web of a beam calculated for the equivalent stress for combined forces (Cl 3.2.1.3.)		

(1) It is forecasted that the symbols shall be adapted to the ISO standard 2553 at the next edition of the Design Rules, when the addition of this standard will be definitively adopted.





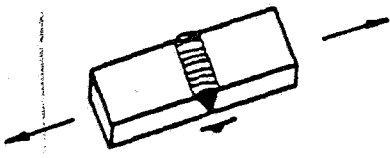
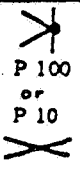
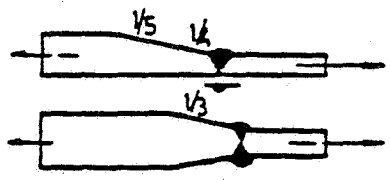
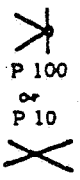
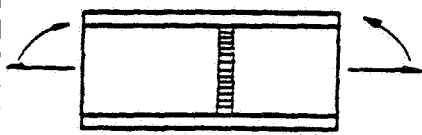
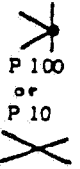
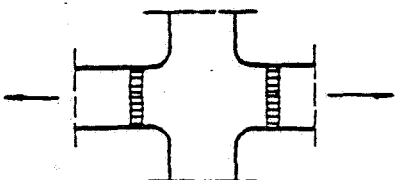
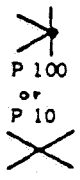
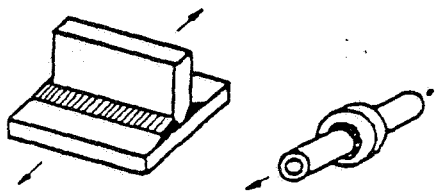

Case K_0 - Slight stress concentration (continued)

Reference	Description	Figure	Symbol ⁽¹⁾
0,5	Butt weld (O.Q.) in the case of longitudinal shear		
0,51	K-weld (O.Q.) or fillet weld (O.Q.) in the case of longitudinal shear		

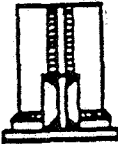

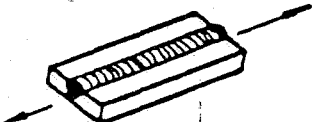
Case K_1 - Moderate stress concentration

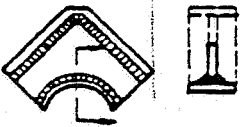
Reference	Description	Figure	Symbol ⁽¹⁾
1,1	Parts joined by butt welding (O.Q.) at right angles to the direction of the forces		
1,11	Parts of different thickness butt welded (O.Q.) at right angles to the direction of the forces. Asymmetrical slope : 1 in 4 to 1 in 5 (or symmetrical slopes : 1 in 3)		
1,12	Butt weld (O.Q.) executed for transverse joint of web plate		
1,13	Gusset joined by butt welding (O.Q.) at right angles to the direction of the forces		
1,2	Continuous main member to which are joined by continuous K-welds (S.Q.) parts at right angles to the direction of forces		





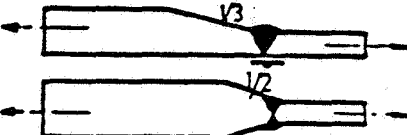

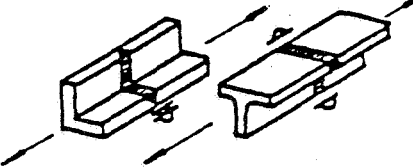
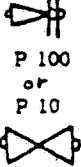
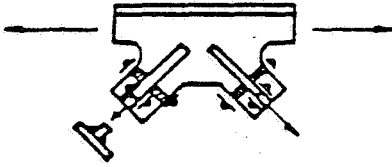
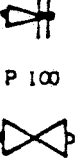
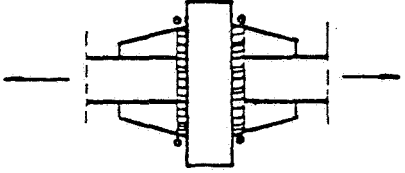
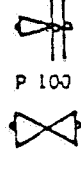



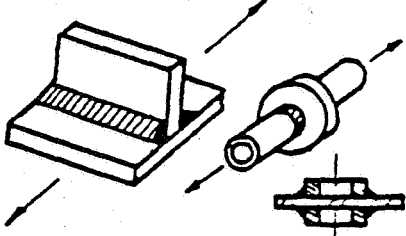

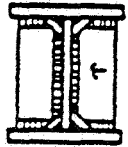
Case K₁ - Moderate stress concentration (continued)

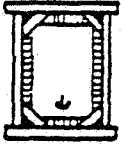
Reference	Description	Figure	Symbol ⁽¹⁾
1,21	Web plate to which stiffeners are joined at right angles to the direction of the forces by means of fillet welds (S.Q.) which extend round the corners of the web stiffeners		
1,3	Parts joined by butt welding parallel to the direction of the forces (without checking the welding)		
1,31	K-weld (S.Q.) between curved flange and web		

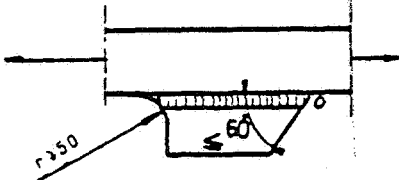
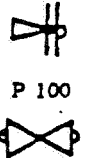
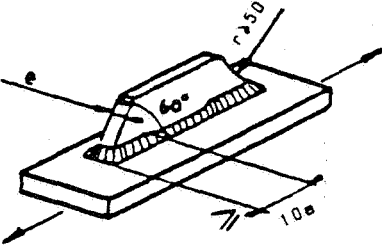

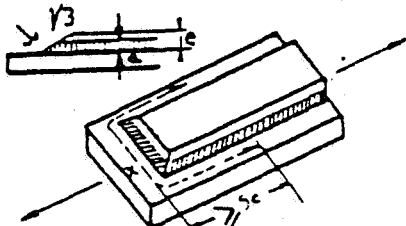



Case K₂ - Medium stress concentration

Reference	Description	Figure	Symbol ⁽¹⁾
2,1	Parts of different thickness butt welded (O.Q.) at right angles to the direction of the forces. Asymmetrical slope : 1 in 3 (or symmetrical slopes : 1 in 2)		
2,11	Sections joined by butt welds (S.Q.) at right angles to the direction of the forces		 P 100 or P 10
2,12	Section joined to a gusset by a butt weld (S.Q.) at right angles to the direction of the forces		 P 100
2,13	Butt weld (S.Q.) at right angles to the direction of the forces, made at intersection of flats, with welded auxiliary gussets. The ends of the welds are ground, avoiding notches		 P 100

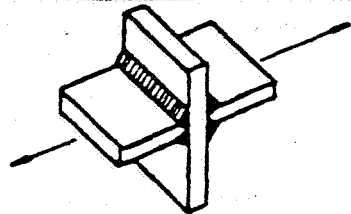

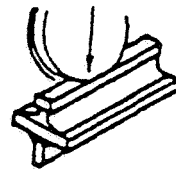



Case K₂ - Medium stress concentration (continued)

Reference	Description	Figure	Symbol ⁽¹⁾
2,2	Continuous main member to which transverse diaphragms, web stiffeners, rings or hubs are fillet welded (S.Q.) at right angles to the direction of the forces		
2,21	Web in which fillet welds (S.Q.) are used to secure transverse web stiffeners with cut corners, the welds not extending round the corners		
2,22	Transverse diaphragm secured by fillet welds (S.Q.) with cut corners, in which the welds do not extend round the corners		
2,3	Continuous main member to the edges of which are butt welded (S.Q.) parts parallel to the direction of the forces. These parts terminate in bevels or radii. The ends of the welds are ground avoiding notches		 <p>P 100</p>
2,31	Continuous main member to which are welded parts parallel to the direction of the forces. These parts terminate in bevels or radii. Valid where the ends of the welds are K-welds (S.Q.) over a length equal to ten times the thickness provided that the ends of the welds are ground avoiding notches		
2,33	Continuous member to which a flat (1 in 3 bevel) is joined by a fillet weld (S.Q.), the fillet weld being executed in the X area, with $a = 0,5 e$		
2,34	K-weld (O.Q.) made between curved flange and web		

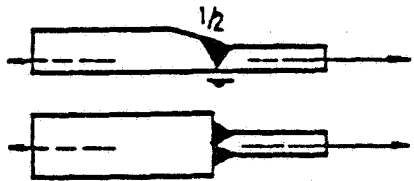
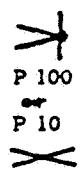

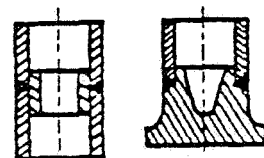

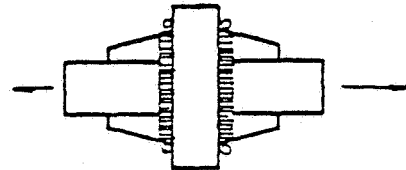





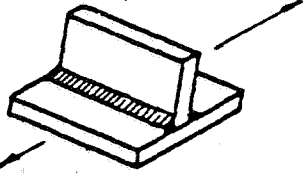

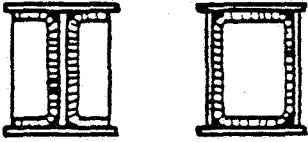
Case K₂ - Medium stress concentration (continued)

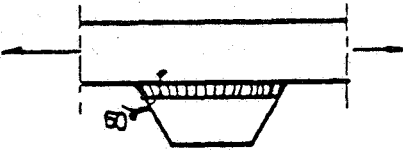
Reference	Description	Figure	Symbol ⁽¹⁾
2,4	Cruciform joint made with K-welds (S.Q.) perpendicular to the direction of the forces		D 
2,41	K-weld (S.Q.) between flange and web in the case of load concentrated in the plane of the web at right angles to the weld		
2,5	K-weld (S.Q.) joining parts stressed in bending or shear		

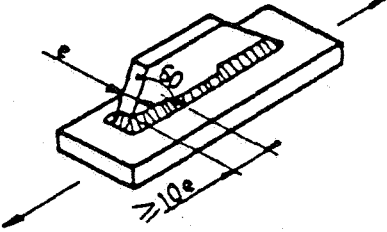

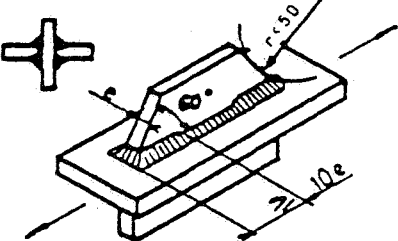

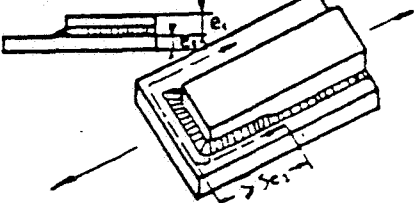





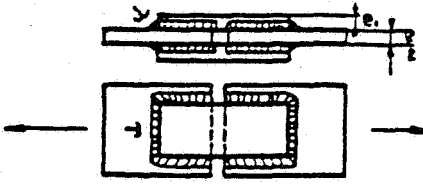

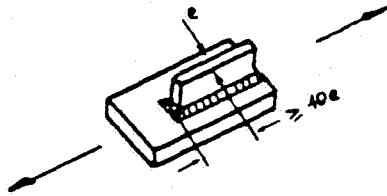

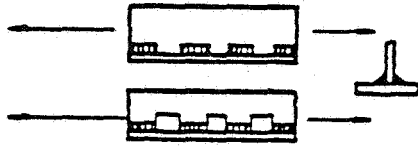
Case K₃ - Severe stress concentration

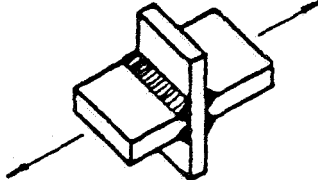
Reference	Description	Figure	Symbol ⁽¹⁾
3,1	Parts of different thickness connected by butt welds (O.Q.) at right angles to the direction of the forces. 1 in 2 asymmetrical slope, or symmetrical position without blend slope		 P 100 P 10
3,11	Butt weld with backing strip and no backing run. Backing strip secured by intermittent tack welds		
3,12	Tubes joined by butt welds whose root is supported by a backing piece and not covered by a backing run		
3,13	Butt weld (O.Q.) at right angles to the direction of the forces at the intersection of flats with welded auxiliary gussets. The ends of the welds are ground, avoiding notches		 X

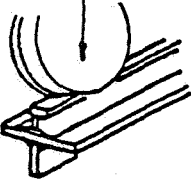



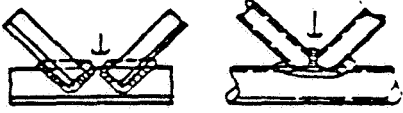





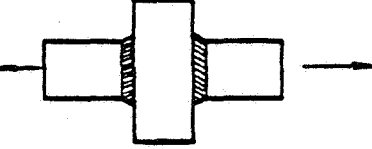

Case K₃ - Severe stress concentration (continued)

Reference	Description	Figure	Symbol ⁽¹⁾
3,2	Continuous main member to which parts are fillet welded (O.Q.) at right angles to the direction of the forces. These parts take only a small portion of the loads transmitted by the main member		
3,21	Web and stiffener or transverse diaphragm secured by uninterrupted fillet weld (O.Q.)		
3,3	Continuous member to the edges of which are butt welded (O.Q.) parts parallel to the direction of the forces. These parts terminate in bevels and ends of the welds are ground avoiding notches		
3,31	Continuous member to which are welded parts parallel to the direction of the forces. These parts terminate in bevels or radii. Valid where the ends of the welds are fillet welds (S.Q.) over a length equal to 10 times the thickness, provided that the ends of the welds are ground, avoiding notches		
3,32	Continuous member through which extends a plate, terminating in bevels or radii parallel to the direction of the forces, secured by K-weld (O.Q.) over a length equal to 10 times the thickness		
3,33	Continuous member to which is welded a flat parallel to the direction of the forces, by means of fillet weld (S.Q.) in the indicated area when $e_1 < 1,5 e_2$		

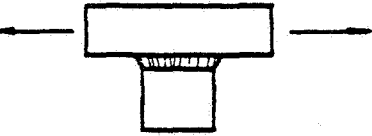
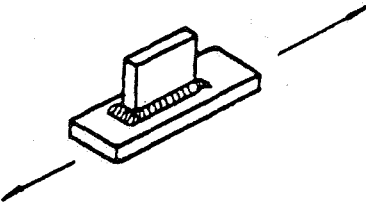

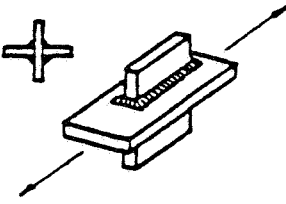

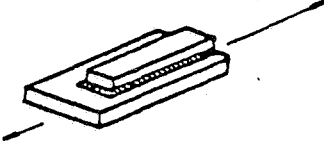





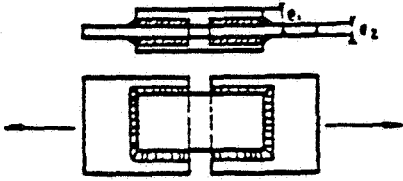

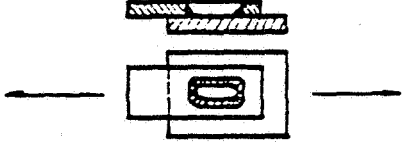
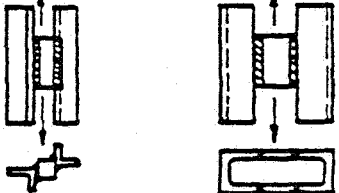
Case K₃ - Severe stress concentration (continued)

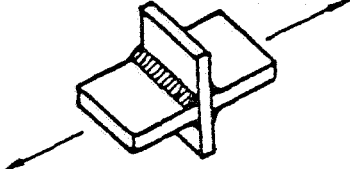
Reference	Description	Figure	Symbol ⁽¹⁾
3,34	Members at the extremity of which connecting gussets are secured by a fillet weld (S.Q.) when $e_1 < e_2$ In case of unilateral gusset allow for eccentric load		
3,35	Continuous member to which stiffeners parallel to the direction of the forces are welded. The ends of the welds are fillet welds (S.Q.) over a length equal to ten times the thickness and are ground avoiding notches		
3,36	Continuous member to which stiffeners parallel to the direction of the forces are secured by fillet welds (O.Q.) which are intermittent or made between indentations		
3,4	Cruciform joint made with K-weld (O.Q.) at right angles to the direction of the forces		
3,41	K-weld (O.Q.) between flange and web in case of concentrated load in the plane of the web at right angles to the weld		
3,5	K-weld (O.Q.) joining parts stressed in bending and shear		
3,7	Continuous member to which sections or tubes are fillet welded (S.Q.)		

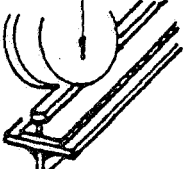
Case K₄ - Very severe stress concentration

Reference	Description	Figure	Symbol ⁽¹⁾
4,1	Parts of different thickness butt welded (O.Q.) at right angles to the direction of the forces. Asymmetrical position without blend slope		
4,11	Butt welds (O.Q.) at right angles to the direction of the forces, at the intersection of flats (no auxiliary gussets)		
4,12	Single bevel weld at right angles to the direction of the forces, between intersecting parts (cruciform joint)		
4,3	Continuous member to the sides of which are welded parts ending at right angles, parallel to the direction of the forces		
4,31	Continuous member to which parts, ending at right angles, parallel to the direction of the forces, and receiving a large proportion of the loads transmitted by the main member, are secured by fillet weld (O.Q.)		
4,32	Continuous member through which extends a plate ending at right angles and secured by fillet welding (O.Q.)		
4,33	Continuous member on which a flat is secured by means of a fillet weld (O.Q.) parallel to the direction of the forces		

Case K₄ - Very severe stress concentration (continued)

Reference	Description	Figure	Symbol (1)
4,34	Joint plate secured by (O.Q.) fillet welds ($e_1 = e_2$). In case of unilateral joint plate allow for eccentric loads		
4,35	Parts welded one on the other secured by fillet welds (O.Q.) in a slot or in holes		
4,36	Continuous members between which connecting gussets are secured by fillet welds (O.Q.) or butt welds (O.Q.)		 
4,4	Cruciform joint made with fillet weld (O.Q.) at right angles to the direction of the forces		 
4,41	Fillet weld (O.Q.) between flange and web in the case of concentrated load in the plane of the web at right angles to the weld		
4,5	Fillet welds (O.Q.) joining parts stressed in bending and shear		 
4,7	Continuous member to which sections or tubes are connected by fillet welds (O.Q.)		

EXAMPLES OF FATIGUE CHECKS
FOR A WELDED WEB TO FLANGE JOINT

STEEL St 37

TOP FLANGE OF GIRDER OF AN OVERHEAD TRAVELLING
CRANE ON WHICH A CRAB RUNS

(Combined check for fatigue and elastic limit)

The results of stress calculations in the top flange of the girder are as follows :

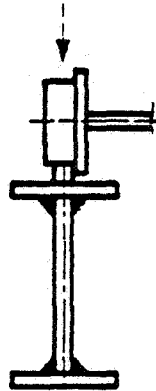

Longitudinal compression :

$$\sigma_x \text{ max} = - 140 \text{ N/mm}^2$$

$$\sigma_x \text{ min} = - 28 \text{ N/mm}^2$$

from which $\kappa = 0,2$

Lateral compression when the crab wheel passes :

$$\sigma_y \text{ max} = - 100 \text{ N/mm}^2$$

$$\sigma_y \text{ min} = 0$$

from which $\kappa = 0$

Shear : changing sign when passing from one side to the other of the section :

$$\tau_{xy} \text{ max} = \pm 40 \text{ N/mm}^2$$

from which $\kappa = -1$

Equivalent stress :

$$\sqrt{(-140)^2 + (-100)^2 - 140 \times 100 + 3 \times 40^2} = 144 < 160 \text{ N/mm}^2 (\sigma_a)$$

acceptable (See clause 3.2.1.3.).

CHECKING FOR FATIGUE AND ELASTIC LIMIT

FIRST EXAMPLE

COMPONENT IN GROUP E4 WITH FILLET WELD (O.Q.)

1 - CHECKING MATERIAL ADJACENT TO THE WELDING

a) Longitudinal compression : case K_0 (reference 0,31)

Checking for elastic limit :

$$\sigma_a = 160 \text{ N/mm}^2 \quad (\text{table T. 3.2.1.1.})$$

$$\sigma_x \text{ max} = - 140 \text{ N/mm}^2$$

from which

$$|\sigma_x \text{ max.}| < \sigma_a$$

Checking for fatigue :

$$\sigma_w = 193,5 \text{ N/mm}^2 \quad (\text{table T.A. 3.6.1.})$$

$$\sigma_a = \frac{5}{3} \sigma_w = 322,5 \text{ N/mm}^2$$

$$\sigma_{+1} = 0,75 \sigma_R = 270 \text{ N/mm}^2$$

$$\sigma_t \text{ is limited to } 270 \text{ N/mm}^2$$

$$\sigma_c = - 1,2 \times \sigma_t = - 324 \text{ N/mm}^2$$

$$\sigma_{xa} = - 324 \text{ N/mm}^2$$

$$|\sigma_x \text{ max}_i| < |\sigma_{xa}|$$

b) Lateral compression : case K_4 (reference 4,41)

Checking for elastic limit :

$$\sigma_a = 160 \text{ N/mm}^2 \quad (\text{table T. 3.2.1.1.})$$

$$\sigma_y \text{ max} = - 100 \text{ N/mm}^2$$

$$|\sigma_y \text{ max}| < \sigma_a$$

Checking for fatigue :

$$\sigma_w = 62,2 \text{ N/mm}^2 \quad (\text{table T.A. 3.6.1.})$$

$$\sigma_a = \frac{5}{3} \cdot \sigma_w = 103,7 \text{ N/mm}^2$$

$$\sigma_t = \sigma_o = 107,7 \text{ N/mm}^2 \quad (\text{formula (3)})$$

$$\sigma_c = 1,2 \times \sigma_t = 124,4 \text{ N/mm}^2$$

$$\sigma_{ya} = -124,4 \text{ N/mm}^2$$

$$|\sigma_y \text{ max}| < |\sigma_{ya}|$$

c) Shear in the material

Checking for elastic limit :

$$\tau_{xya} = \frac{160}{\sqrt{3}} = 92,4 \text{ N/mm}^2 \quad (\text{table T. 3.2.1.1.})$$

$$\tau_{xy \text{ max}} = \pm 40 \text{ N/mm}^2$$

$$\tau_{xy \text{ max}} < \tau_a$$

Checking for fatigue :

$$\tau_w = \frac{182,1}{\sqrt{3}} = 105,1 \text{ N/mm}^2 \quad (\text{table T.A. 3.6.1.})$$

$$\tau_a = \tau_w = 105,1 \text{ N/mm}^2 \quad (\text{formula ((1))})$$

$$\tau_{xya} = 105,1 \text{ N/mm}^2$$

$$\tau_{xy \text{ max}} = 40 \text{ N/mm}^2$$

$$|\tau_{xy \text{ max}}| < \tau_a$$

d) Checking for combined loads :

Use formula (5) :

Condition to be checked :

$$\left(\frac{-140}{-324}\right)^2 + \left(\frac{-100}{-124,4}\right)^2 - \frac{(-140)(-100)}{324 \times 124,4} + \left(\frac{40}{92,4}\right)^2 = 0,672 < 1$$

therefore satisfied.

2 - CHECKING IN THE WELD

If the thickness of the two welds is equal to the thickness of the web, the stresses $\sigma_x \max$, $\sigma_y \max$ and $\tau_{xy} \max$ have the same values as in 1 - above.

The permissible tensile and compressive stresses are the same as for 1 - above (in the material), with respect to both checking for elastic limit and checking for fatigue. It follows that we can dispense with a check for the cases corresponding to a) and b) above.

The permissible shear stresses, as regards checking for elastic limit, are obtained by dividing the permissible tensile stress by $\sqrt{2}$, instead of $\sqrt{3}$ in the case of the material itself. They are therefore more favourable than those used in cases c) and d) above.

To sum up, we may confine ourselves to checking for fatigue the cases corresponding to c) and d) above.

c) Shear in the weld :

$$\begin{aligned}\tau_{xya} &= \frac{193,5}{\sqrt{2}} = 136,8 \text{ N/mm}^2 && \text{(table T.A. 3.6.1.)} \\ \tau_{xy \max} &= 40 \text{ N/mm}^2\end{aligned}$$

from which

$$|\tau_{xy \max}| < |\tau_{xya}|$$

d) Checking for combined loads :

Using formula (5)

Condition to be checked :

$$\left(\frac{-140}{-324}\right)^2 + \left(\frac{-100}{-124,4}\right)^2 - \frac{(-140)(-100)}{324 \times 124,4} + \left(\frac{40}{136,8}\right)^2 = 0,571 < 1$$

therefore satisfied.

Note : If the component had been classified in group E6, the stress $\sigma_y \max = -100 \text{ N/mm}^2$ would be too high, since the permissible fatigue stress for case K_4 and $\kappa = 0$ is only :

$$\sigma_{ya} = 1,2 \times \frac{5}{3} \times 41 = 82 \text{ N/mm}^2$$

SECOND EXAMPLE

COMPONENT IN GROUP E6 - K WELD (S.Q.)

The loads - and therefore the stresses - will be assumed to be the same as in the first example.

As the permissible stresses for the elastic limit checks are not affected by the change of group, nor by the type of weld, the calculations in the first example may, in this respect, be reproduced as they stand.

We shall therefore confine ourselves to checking for fatigue.

1 - CHECKING MATERIAL ADJACENT OF THE WELD

a) Longitudinal compression, case K_0 (reference 0,33)

$$\sigma_w = 127,5 \text{ N/mm}^2 \quad (\text{table T.A. 3.6.1.})$$

$$\sigma_o = \frac{5}{3} \sigma_w = 212,5 \text{ N/mm}^2$$

$$\sigma_{+1} = 0,75 \times \sigma_R = 270 \text{ N/mm}^2$$

$$\sigma_t = \frac{212,5}{1 - (1 - \frac{212,5}{270}) \times 0,2} = 222,0 \text{ N/mm}^2 \quad (\text{formula (3)})$$

$$\sigma_c = 1,2 \times 222,0 = 266 \text{ N/mm}^2 \quad (\text{formula (4)})$$

$$\sigma_{xa} = -266 \text{ N/mm}^2$$

$$\sigma_x \text{ max} = -140 \text{ N/mm}^2$$

from which

$$|\sigma_x \text{ max}| < |\sigma_{xa}|$$

b) Lateral compression : case K_2 (reference 2,41)

$$\sigma_w = 95,6 \text{ N/mm}^2 \quad (\text{table T.A. 3.6.1.})$$

$$\sigma_o = \frac{5}{3} \sigma_w = 159,3 \text{ N/mm}^2$$

$$\sigma_t = \sigma_o = 159,3 \text{ N/mm}^2 \quad (\text{formula (3)})$$

$$\sigma_c = 1,2 \times \sigma_t = 191,2 \text{ N/mm}^2$$

$$\sigma_{ya} = -191,2 \text{ N/mm}^2$$

$$\sigma_y \text{ max} = -100 \text{ N/mm}^2$$

from which

$$|\sigma_y \text{ max}| < |\sigma_{ya}|$$

c) Shear in the material :

$$\tau_{xya} = \frac{147,8}{\sqrt{3}} = 85,3 \text{ N/mm}^2 \quad (\text{table T.A. 3.6.1.})$$

$$\tau_{xy \text{ max}} = \pm 40 \text{ N/mm}^2$$

from which

$$|\tau_{xy \text{ max}}| < |\tau_{xya}|$$

d) Checking for combined loads :

Use formula (5)

Condition to be checked :

$$\left(\frac{-140}{-266}\right)^2 + \left(\frac{-100}{-191,2}\right)^2 - \frac{(-140)(-100)}{266 \times 191,2} + \left(\frac{40}{85,3}\right)^2 = 0,495 < 1$$

therefore satisfied.

2 - CHECKING IN THE WELD

Same reasoning as for first example.

Leaving cases c) and d) to be checked for fatigue.

c) Shear in the weld :

$$\tau_{xya} = \frac{127,5}{\sqrt{2}} = 90,2 \text{ N/mm}^2 \quad (\text{table T.A. 3.6.1.})$$

$$\tau_{xy \text{ max}} = \pm 40 \text{ N/mm}^2$$

from which

$$|\tau_{xy \text{ max}}| < |\tau_{xya}|$$

d) Checking for combined loads :

Use formula (5)

Condition to be checked :

$$\left(\frac{-140}{-266}\right)^2 + \left(\frac{-100}{-191,2}\right)^2 - \frac{(-140)(-100)}{266 \times 191,2} + \left(\frac{40}{90,2}\right)^2 = 0,472 < 1$$

therefore satisfied.