

A
0
0
0
3
1
9
6
9
9



UC SOUTHERN REGIONAL LIBRARY FACILITY

TOYS: THEIR DESIGN AND CONSTRUCTION

J. KAY and C. T. WHITE

ifornia
onal
ity



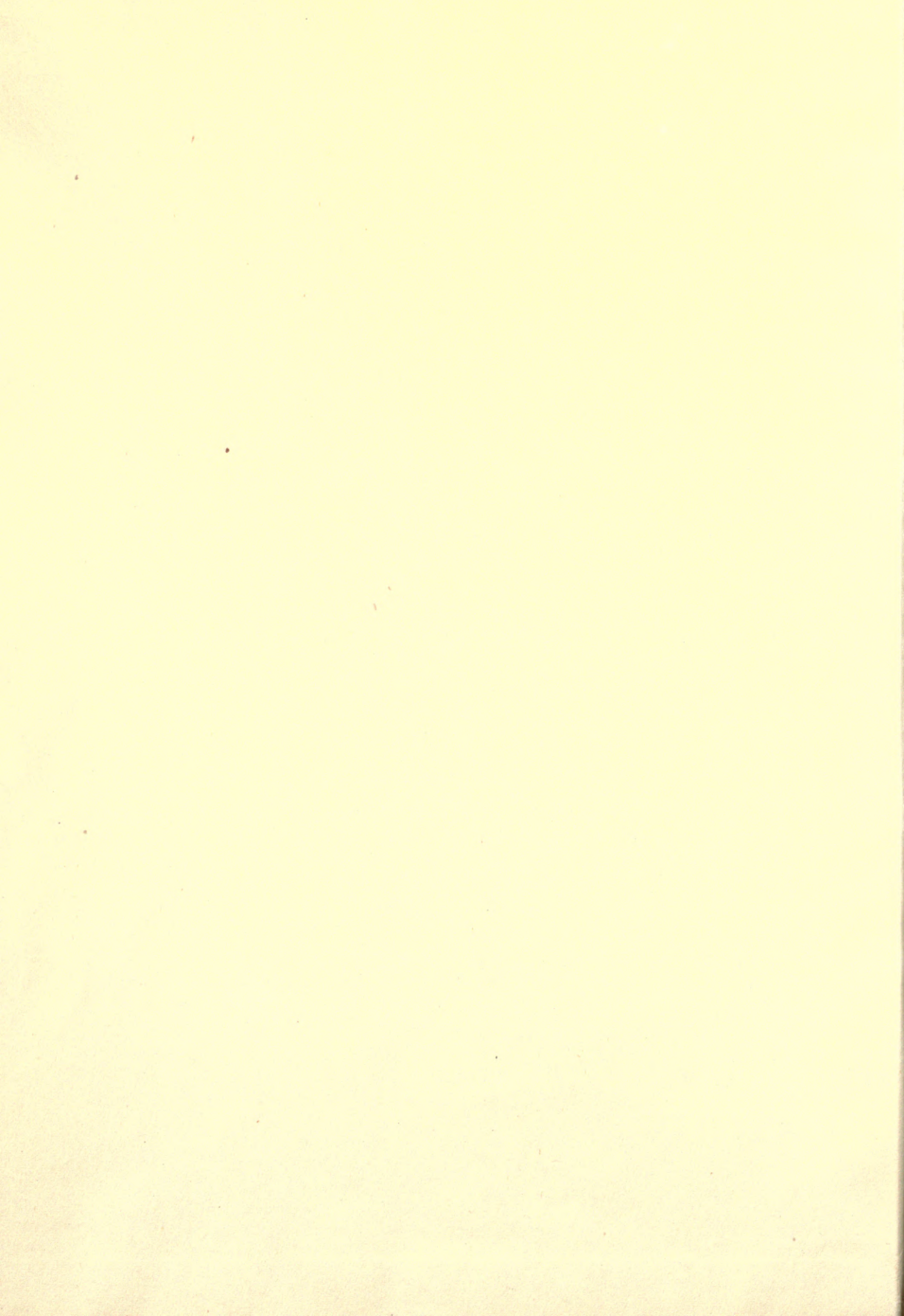

TOYS
THEIR DESIGN AND CONSTRUCTION



SOME OF THE TOYS BEING USED IN A DAY NURSERY

[Frontispiece

TOYS: THEIR DESIGN AND CONSTRUCTION

J. KAY and C. T. WHITE

WITH ILLUSTRATIONS
IN LINE AND HALF-TONE

CHAS. A. BENNETT CO., INC.
PEORIA · ILLINOIS

PRINTED IN GREAT BRITAIN

C O N T E N T S

SOME OF THE TOYS BEING USED IN A DAY NURSERY	<i>frontispiece</i>	
INTRODUCTION	PAGE	7
PLATES I—VIII	<i>Facing</i>	8
DRESSER WITH DOORS PIVOTED		
CRADLE AND COT		
WHEELED HORSE AND ROCKING HORSE		
ROCKER AND STEPPED SLIDE		
CLIMBING FRAME WITH SLIDE. SEE-SAW		
METAL SWING		
STREAM-LINED LOCOMOTIVE. ROCKING DUCK		
WHEELBARROW AND ENGINE		
JOINTS		10
PEG-TRAIN SET		14
SIMPLE RAILWAY STATION		16
SMALL BOATS		18
SMALL LORRIES		20
BRICKS		22
SIMPLE SENSE-TRAINING APPARATUS		24
FLAT TROLLEY		26
CRADLE		28
COTS		30
DRESSERS		32
FUN BOAT		34
DUCK BOAT		36
FLYING DUCK		38
“TISHY”		40
SMALL ROCKING HORSE		42
DOLL'S HOUSE		44
DOLL'S HOUSE: DINING-ROOM SUITE		48
DOLL'S HOUSE: BEDROOM SUITE.		50
DOLL'S HOUSE: KITCHEN FURNITURE		52
MARIONETTE THEATRE		54
GLOVE-PUPPET THEATRE		56

C O N T E N T S—continued

	PAGE
MODEL THEATRE	58
SCENERY FOR MODEL THEATRE	60
CASTLE	62
WHEELS: THEIR MAKING AND FIXING	64
BREN-GUN CARRIER	70
DUCK CART AND BRICKS	72
ELEPHANT AND CART	74
TIP LORRY	76
BREAKDOWN AND G.P. LORRIES	78
SCOOTER	80
TANK	82
HORSE ON WHEELS	84
SACK TRUCK	86
COASTER	88
DOG ON WHEELS	90
NOAH'S ARK	92
ANIMALS	94
ENGINE	96
STREAM-LINED LOCOMOTIVE	98
WHEELBARROW	102
SMALL SWING	104
METAL SWING	106
SEE-SAW	108
WAREHOUSE TROLLEY	110
LONG SWING	112
TUBULAR ROCKER	114
SMALL SLIDE	116
CLIMBING FRAME AND SLIDE	118
JUNGLE-GYM	120
GENERAL HINTS	122

I N T R O D U C T I O N

This book had its genesis in a number of designs prepared by the authors for use in London handicraft centres. The initial aim was threefold. At a time when little but salvaged timber was available it was hoped that the designs would provide a basis for a scheme of craft training which would include most of the common tool and constructional operations, there was urgent need for the provision of toys and equipment for the large number of nurseries which were being opened, and it seemed desirable that as much as possible of the material salvaged from bombed schools and other buildings should be converted to some useful purpose. The designs proved immediately popular with teachers and pupils, both of whom found fresh enthusiasm in the new line of work and satisfaction in feeling that they were making some real and valuable contribution to the national effort. Further designs were prepared and a steady stream of toys flowed into the nurseries. It is hoped that a similar stimulation will be given to the production of toys and the equipping of nurseries in other parts of the country by the production of the designs in book form.

A good toy should make an instinctive appeal to a child. It should be suitable to his age and development, attractive in form and colour, strong in construction and devoid of sharp edges and dangerous projections. With these qualities it should, wherever possible, combine movement in some form or other. These are the basic requirements of any good toy. But while toys should be so attractive that children immediately wish to play with them, amusement ought not to be regarded as their sole purpose. Properly constructed they are a valuable means of furthering the child's mental and physical development. A few examples may help to illustrate this. The large building bricks on Page 22 provide an opportunity for the exercise of creative ability ; judgment and muscle sense are developed by the use of the hammer peg board, while manipulative skill and an appreciation of shape and size are developed by the use of the posting box, insets and peg shapes on Page 24. The climbing frame and chute on Page 118 provide an incentive for the child to stretch and exercise his arms and shoulders by pulling himself upwards ; the slide down the chute provides a pleasing thrill as a reward for his effort but it also develops his confidence and accustoms him to ignore little shocks and bumps. So, too, the provision of a central bar on the rocker on Page 114 is intended to compel similar stretching and pulling. Two bars, one nearer each seat, might have been provided so that the children could sit upright, but this arrangement would have eliminated very largely the need to stretch the arms and shoulders and legs. Where a nursery is to be equipped with a number of duck carts (Page 72) it is suggested that these and their bricks should be painted in distinctive colours. The bricks may then be heaped on the floor and each child encouraged to collect the

bricks similar in colour to its cart. The children are thus provided with an enjoyable game and, at the same time, a useful colour-training exercise.

Mention has been made of the conversion of salvage into useful toys. It might be helpful to point out a few examples of what has been done in this direction. The metal swing, the tubular rocker, the warehouse trolley and the long swing were designed to be constructed from the damaged tubular frames of nursery beds. The seats of broken Windsor chairs became the seats of the rocker and the swing. Broken "bent-wood" chairs were converted into sack carts and used for the legs of the "Tishy" horse on Page 40. Dumb-bells, now frowned upon for physical training, each made two very useful broad wheels for the warehouse trolley. Short ends of tubing from the rest beds were used as bushes for wheels, as axles and as distance pieces on the metal swing. By the exercise of a little inventiveness and ingenuity much broken and disused apparatus may be converted into useful toys for the nursery.

Reference to the various designs will show that where animal forms are included in a toy little attempt at realism has been made. To most children a simple shape and good proportion, as in the rocking horse on Page 42, are much more pleasing than any attempt at realism, however successful. Simple forms have, therefore, been used throughout except in the animals for the Ark on Page 94, which it was felt should receive more realistic treatment.

Throughout the book the descriptive matter has been kept opposite its illustrations and the latter have, as far as possible, been made self-explanatory. The designs have been prepared for workers with widely varying degrees of experience and craftsmanship. The expert will need little more than the suggestions contained in the drawings; the inexperienced worker, however, before commencing the construction of any toy, is advised to read the text carefully and study the illustrations until he has a clear mental picture of all the operations involved. Only then should he commence the actual construction. By following this advice he may be saved much disappointment and waste of time and material. Whether, therefore, he be the boy working in the school handicraft room, the home craftsman satisfying an urge to construct by making toys for his children, or the expert "in the trade," the user of this book may follow its suggestions with confidence. The toys have been tried out in a large number of nurseries and the methods of construction thoroughly tested.

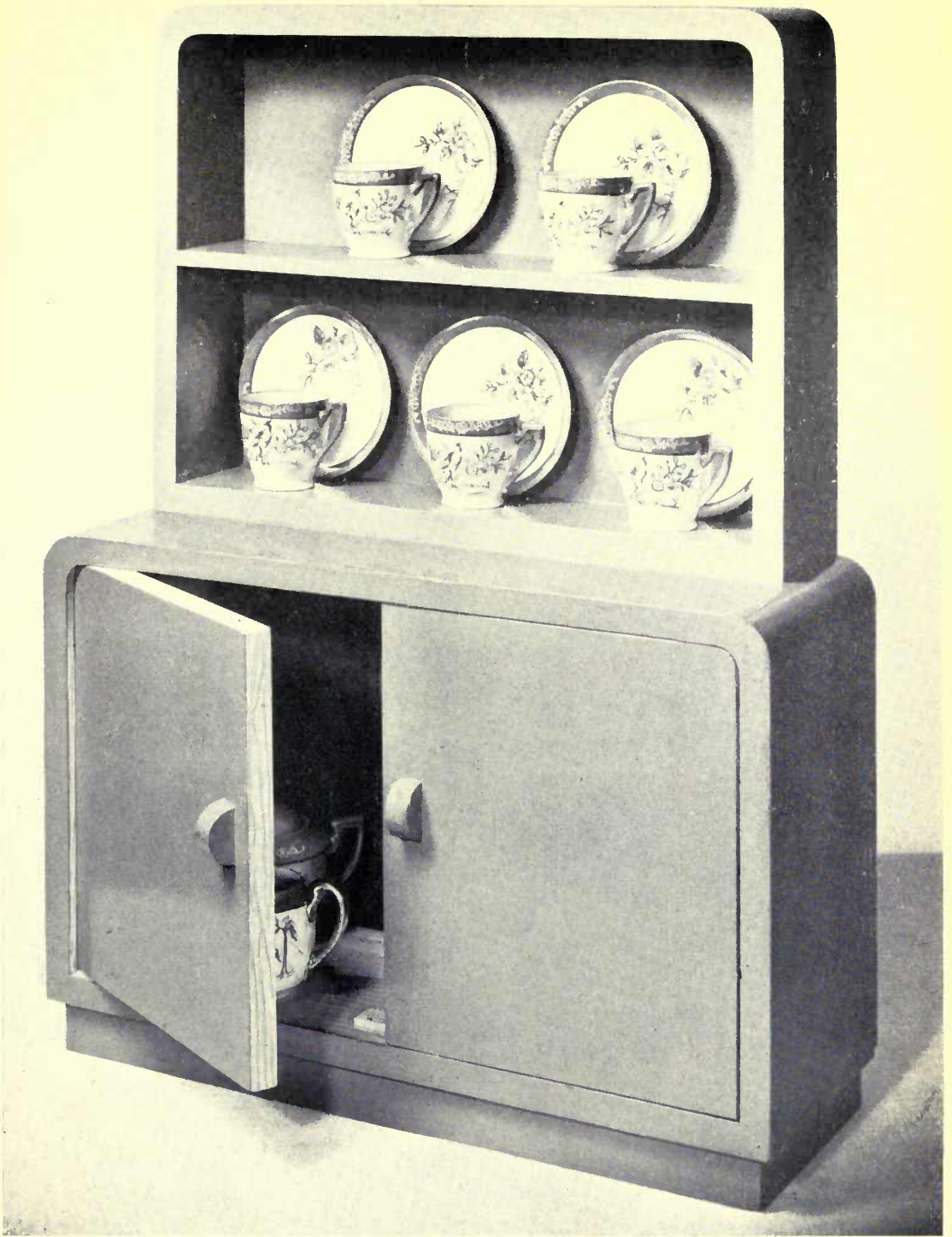

PLATE I.—DRESSER WITH DOORS PIVOTED

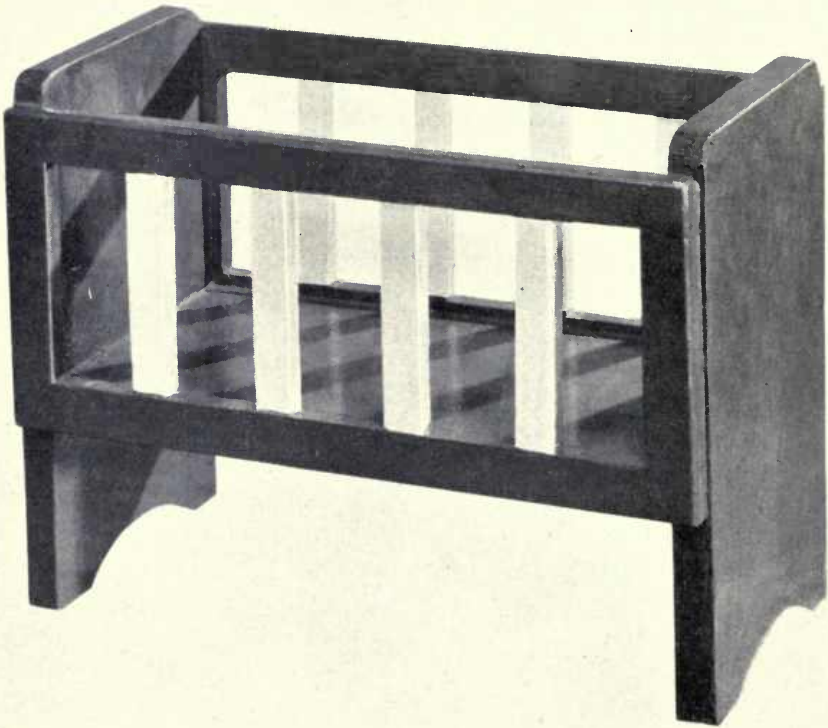
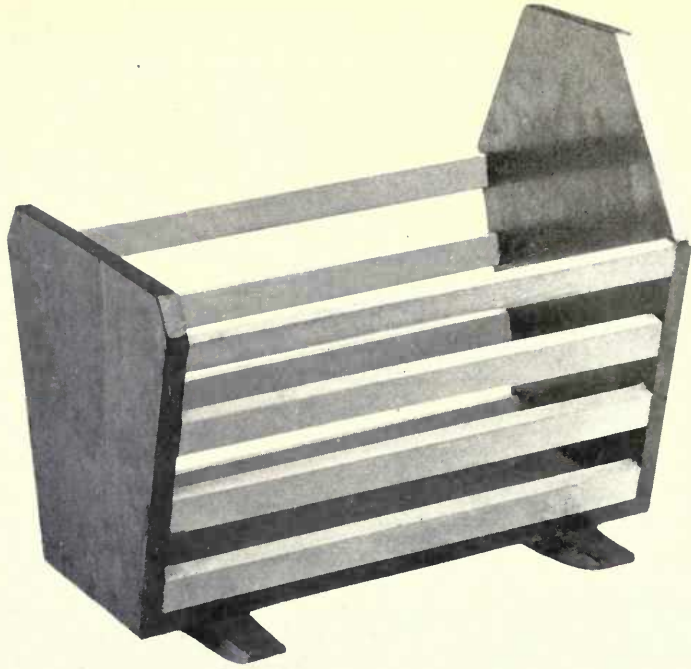

PLATE II.—CRADLE AND COT

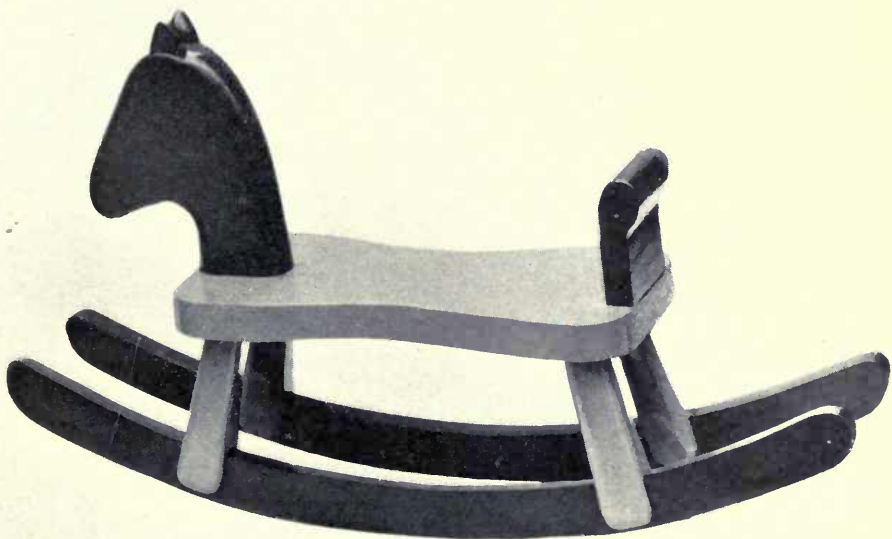
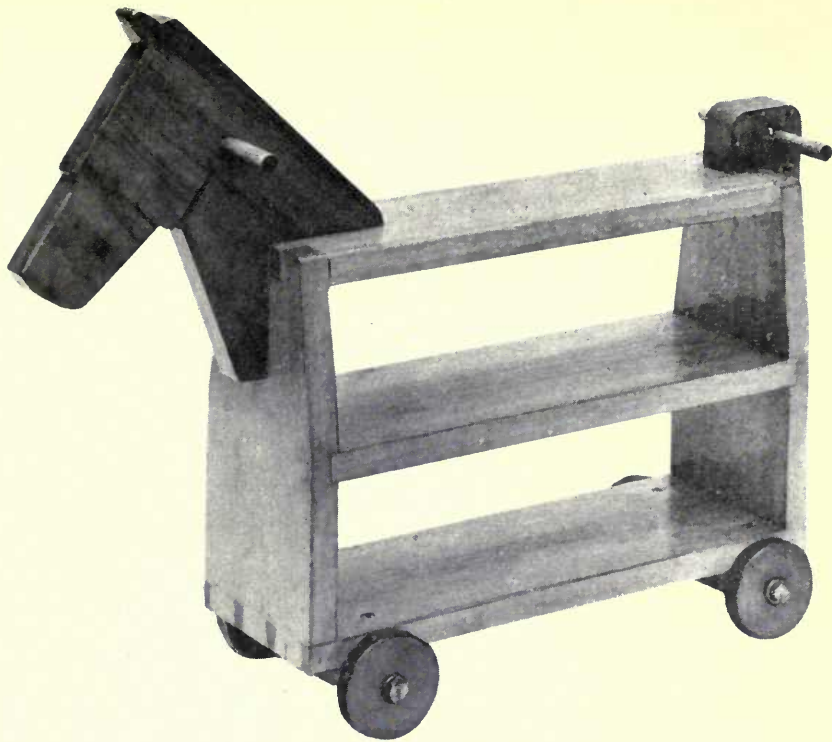

PLATE III.—WHEELED HORSE AND ROCKING HORSE

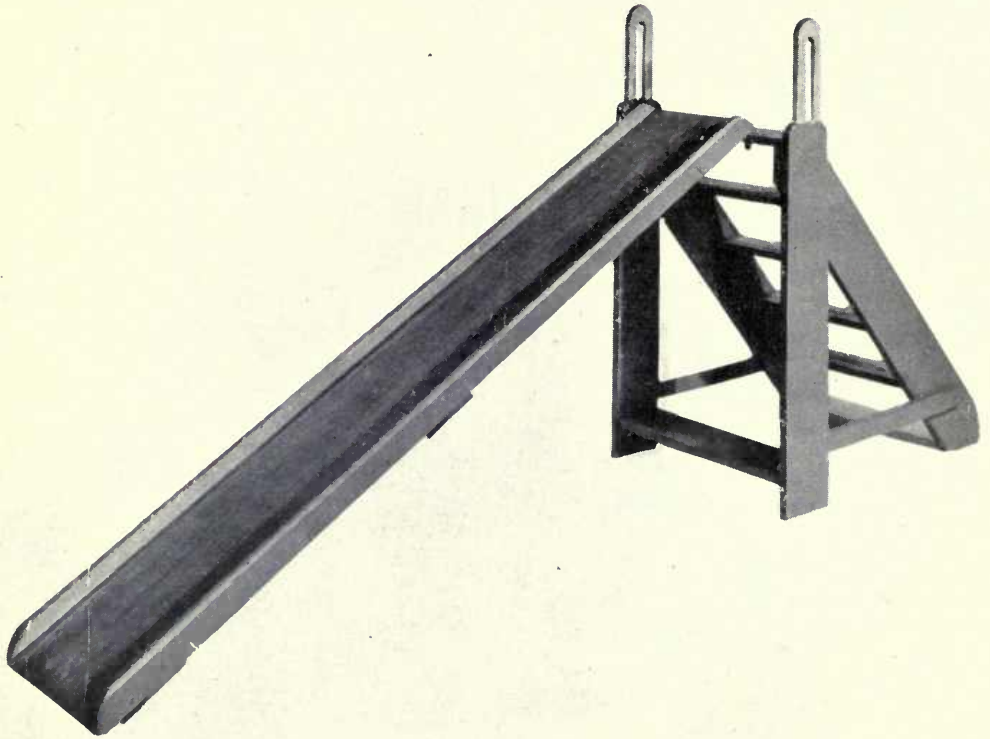
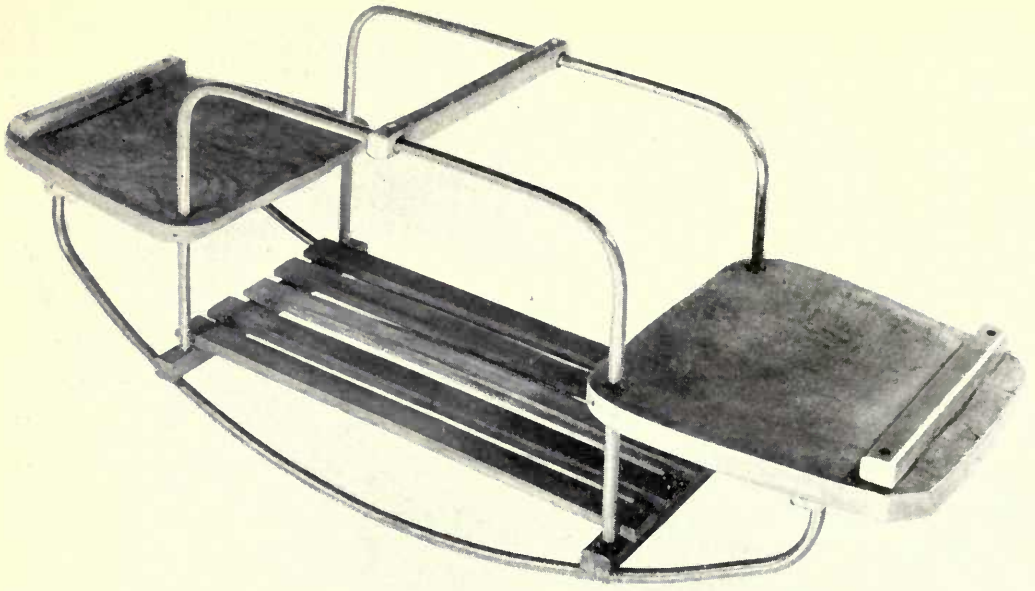

PLATE IV.—ROCKER AND STEPPED SLIDE

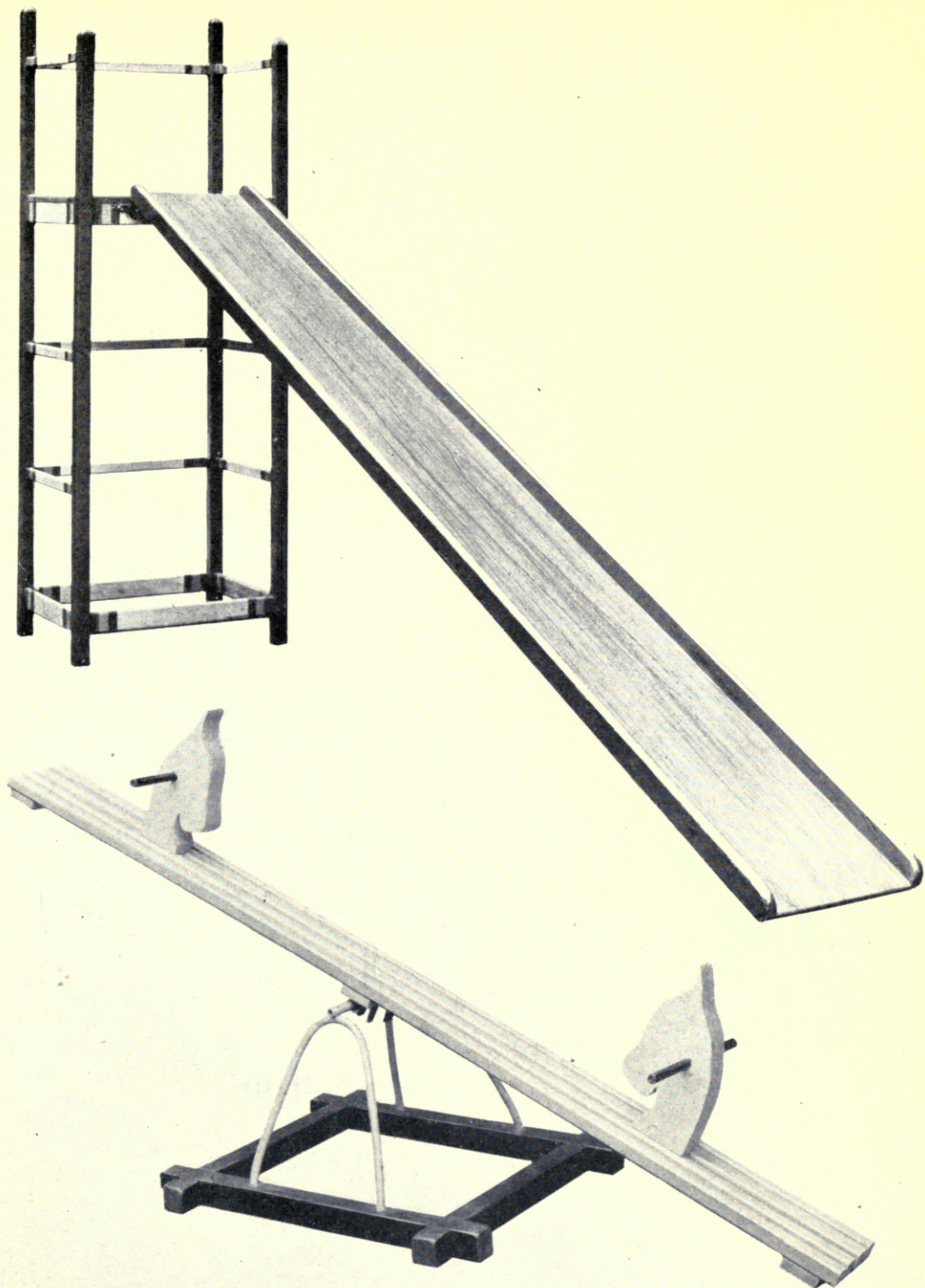

PLATE V.—CLIMBING FRAME WITH SLIDE. SEE-SAW

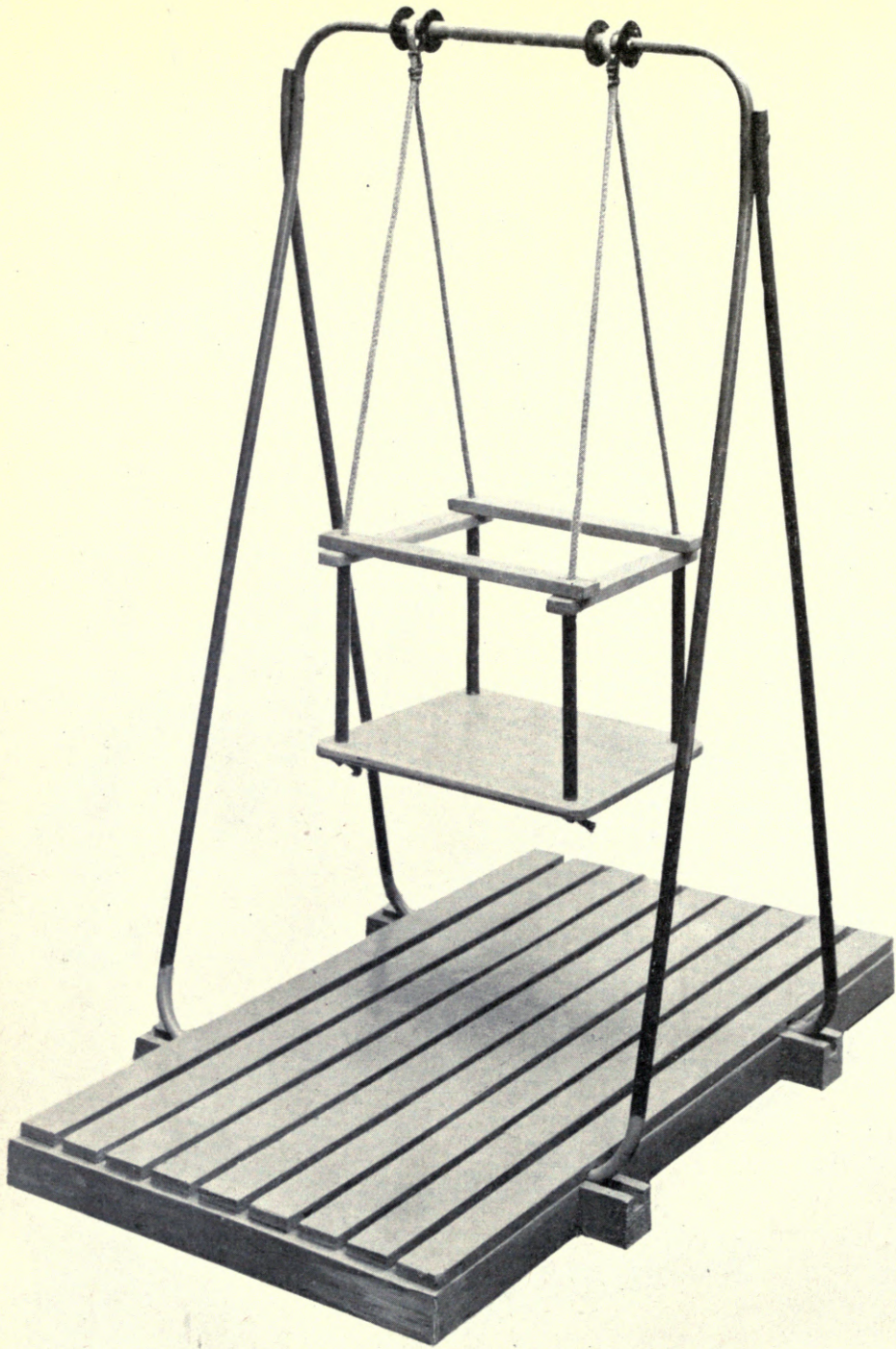

PLATE VI.—METAL SWING

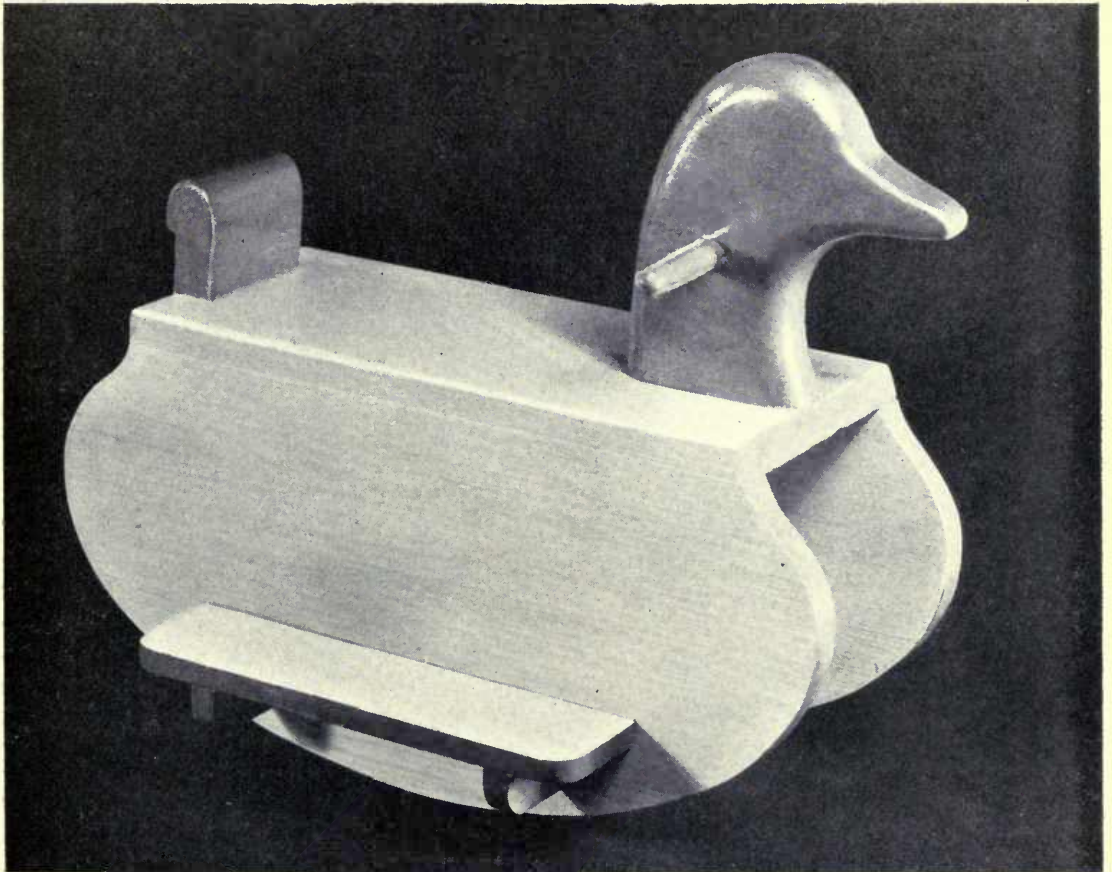
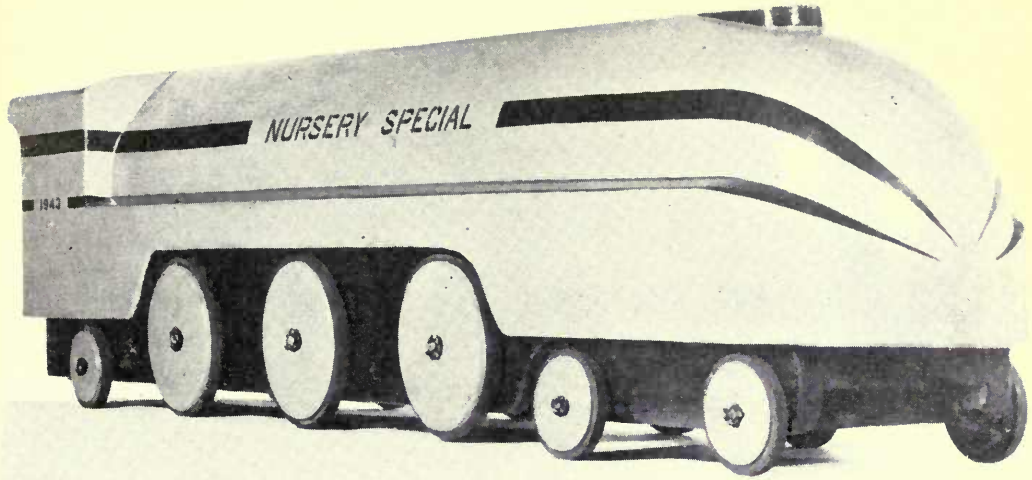

PLATE VII.—STREAM-LINED LOCOMOTIVE. ROCKING DUCK

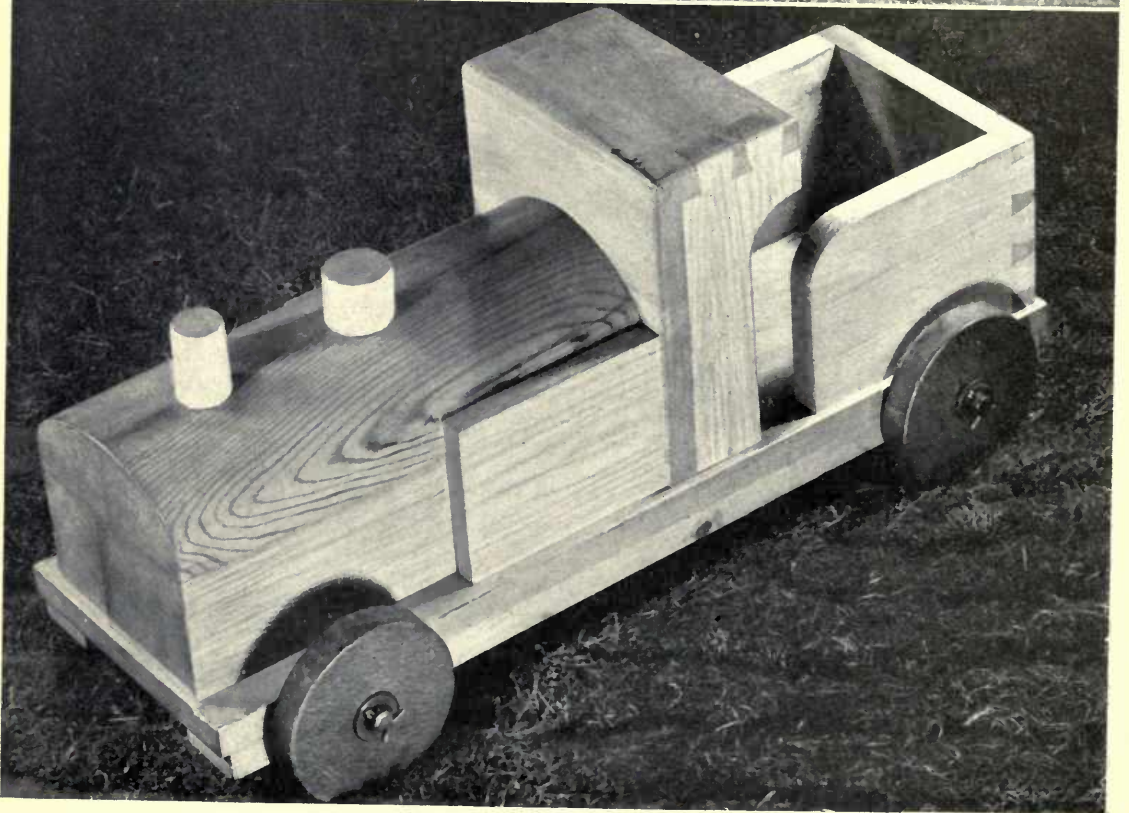
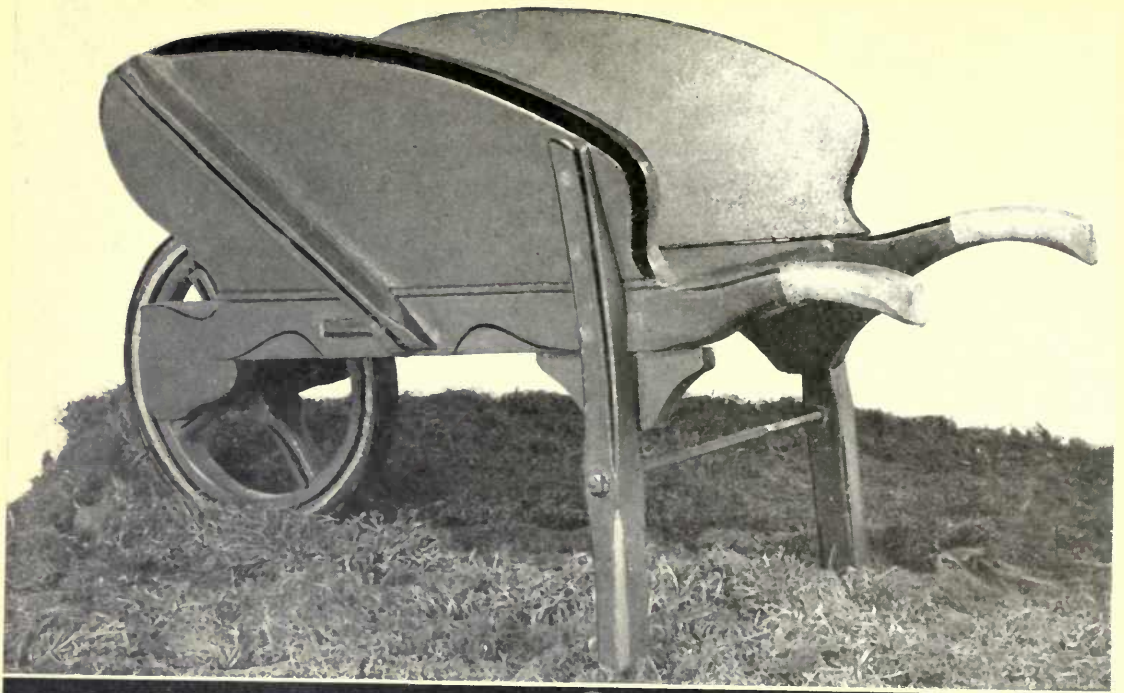

PLATE VIII.—WHEELBARROW AND ENGINE

TOYS

THEIR DESIGN AND CONSTRUCTION

J O I N T S

A well-fitting joint depends upon careful preparation of the timber, accurate marking out with thin pencil and cut lines, the proper use of the try square and gauges, careful cutting with saw and chisel on the waste-wood side of lines, and the retention of the timber in one piece as long as possible. To lessen possibility of error it is advisable to mark, with a "W" or other mark, the "waste" or timber to be removed.

Below are set out brief instructions for making the joints suggested for the toys described in this book.

BUTT JOINT (Fig. 1).—The ends are cut accurately square in both directions, then glued and nailed. Note that into end grain the nails should be driven obliquely.

HOUSING OR GROOVING JOINT (Fig. 1).—Using a try square make two knife-cuts across the side to be grooved. Carry these across the edges. Set the marking gauge to the required depth (usually from $\frac{3}{16}$ " to $\frac{1}{4}$ ") and mark lines on each edge between the knife-cuts. With tenon saw **close to cut line and on waste side of it** saw down to gauge marks. Finally with sharp chisel, and working from both edges, cut out the waste wood.

CROSS HALVING JOINT (Fig. 2).—Mark out width of material with cut lines. From **face side** gauge centre line on both edges between cut lines. On waste side of lines saw down to gauge lines. With sharp chisel and working from both edges cut out waste wood. Fit pieces together and glue or screw if required.

ANGLE HALVING JOINT (Fig. 3).—Prepare each piece by squaring a line round the end equal to the width of the material. Cut the shoulder lines with a knife. Gauge the centre lines. With piece held in vice, saw on the waste side of the gauge line down to level of shoulder. Saw shoulder with timber held on bench hook, then fit together.

TEE HALVING JOINT (Fig. 3).—Cut one piece as for Cross Halving and other as for Angle Halving joint.

TEE BRIDLE JOINT (Fig. 4).—Using a mortice gauge mark out both pieces as in Fig. 4. The distance between the teeth of the gauge should be one-third thickness of material. A single-tooth marking gauge can be used if one set of lines is made from the face side and then the stock of the gauge is moved forward the required distance for the second set. Remove waste with saw and chisel (Fig. 4) and fit together.

ANGLE BRIDLE JOINT (Fig. 5).—This joint is also known as an Open Slot Mortice and Tenon joint. As will be seen from Figs. 4 and 5 both pieces are set out similar to one of the pieces in the previous joint. Both are sawn vertically, one **inside** and the other **outside** the gauge lines.

(Continued on Page 12)

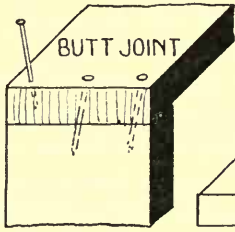

GROOVING OR HOUSING JOINT

FIG 1

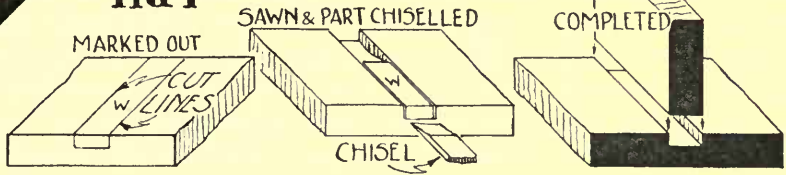

CROSS HALVING FIG 2

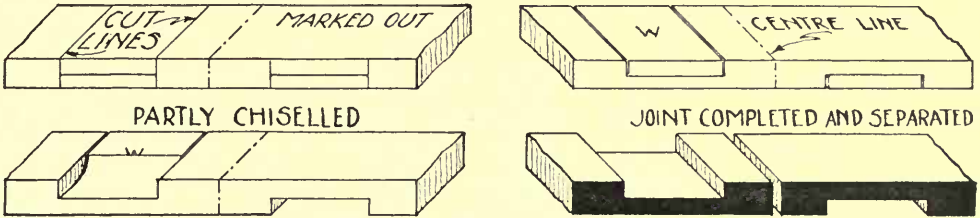

TEE HALVING FIG 3

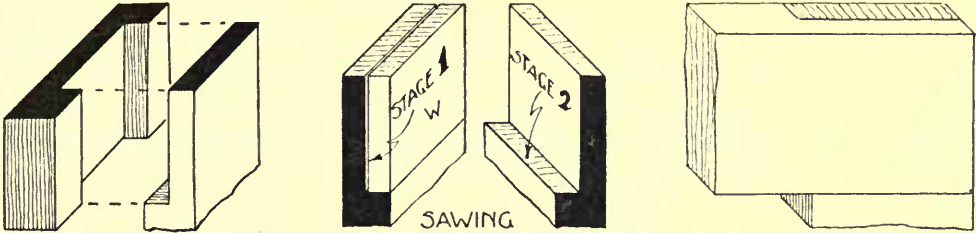

TEE BRIDLE FIG 4

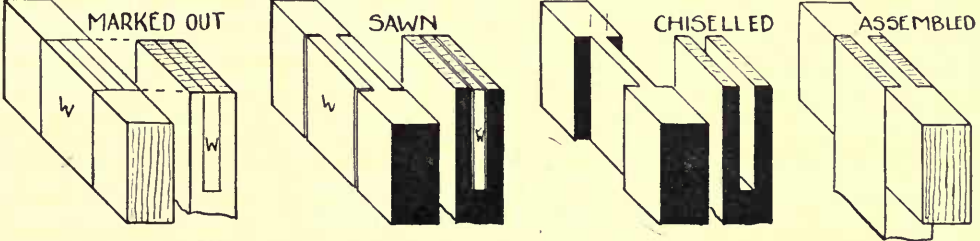

ANGLE BRIDLE FIG 5

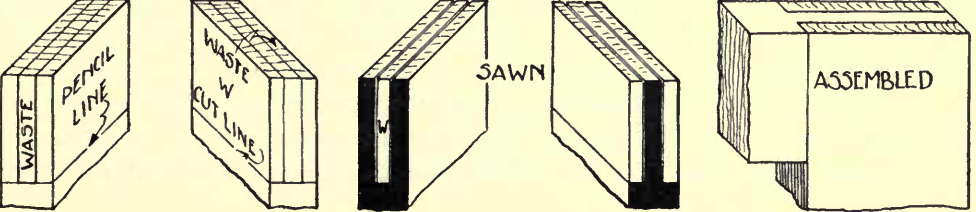

MORTICE AND TENON JOINT (Fig. 1).—Notice similarity of setting out with that of Tee Bridle joint. Mark out round the mortice piece with pencil lines, and the tenon with cut lines. Set a mortice gauge to the width of the chisel nearest to one-third the thickness of the material. Gauge both pieces from the face sides, then cut the mortice from both sides of material. Start in the centre and cut back towards each end of the mortice. Cut wedge-ways about two-thirds depth of mortice. When cutting the tenon make the vertical cuts first, close up to the gauge lines and on the waste-wood side of them. Cut both shoulders. From a piece of hardwood the same thickness as the tenon cut two wedges a little longer than the tenon. Fit the joint and glue both mortice and tenon. Glue wedges and drive in with blows on each alternately.

CORNER OR HAUNCHED MORTICE AND TENON JOINT (Fig. 2).—In this joint the tenon does not go through the morticed piece; mortice and tenon are cut to about three-quarters of width of material. The tenon is cut two-thirds the width of the material but has a shoulder or "haunch" left on it of $\frac{1}{4}$ " or $\frac{3}{8}$ " depending upon the size of the material. Cut the tenon as described above, then make the haunch. Fit and glue joint, then put screw through as in Fig. 2.

DOVETAIL HALVING JOINT (Fig. 3).—Mark out "tail" on end of one piece as in Fig. 3. The angle suggested is 1:7. See small sketch, Fig. 3. This angle varies between 1:6 for soft wood and 1:8 for hardwood. First make the vertical saw-cuts and then the shoulder cuts. Place tail in position on second piece and mark with pencil. Cut and remove waste as with Cross Halving joint.

COMMON DOVETAIL JOINT (Fig. 4).—Square ends of pieces and mark out "pins." The amount of waste should equal the amount of timber left in the pins. Cut and clean out the waste and, with an awl or fine pencil, mark out the sockets. When sawing the sockets it is essential to keep the saw close to the line and on the waste-wood side of it. A sketch is given for making a handy template in wood or brass for the quick marking out of dovetails.

TONGUE AND GROOVE JOINT (Fig. 5).—Mark out both pieces with cut lines as in Fig. 5. Saw, chisel, and fit joint and when completed glue and nail together.

MITRE JOINTS (Fig. 6).—There are two easy ways of cutting this joint. The first is by drawing squares on the ends of the pieces and cutting along the diagonals. This method is often adopted where the pieces to be mitred are flat. The second is by means of a mitre block. This consists of a piece of 2" x 2" section material screwed along a base-board 5" or 6" wide and having cuts at angles of 45° across the top and carried vertically down to the base (Fig. 6). Flat or moulded pieces may be cut with this block.

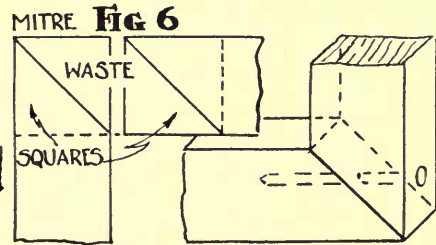
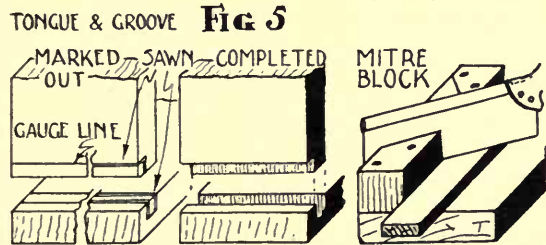
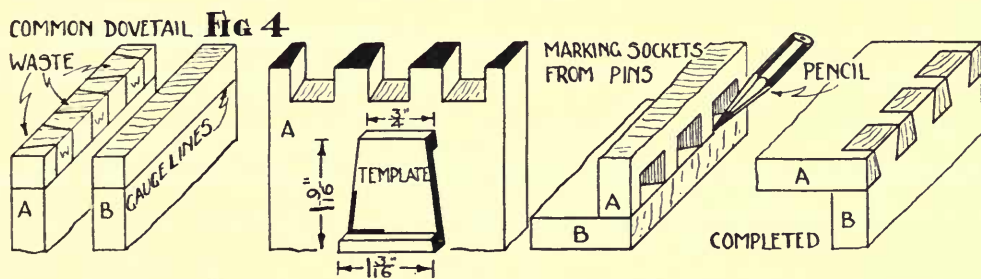
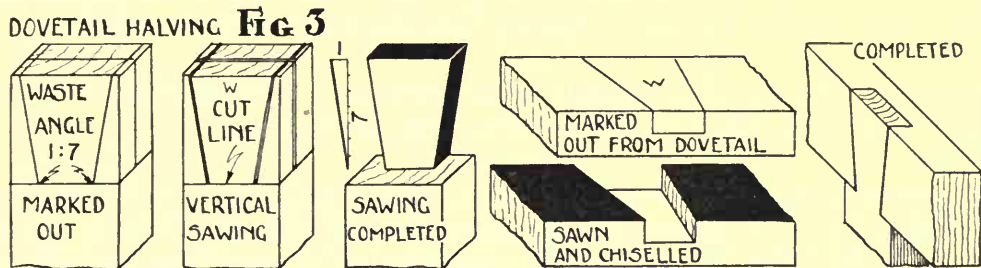
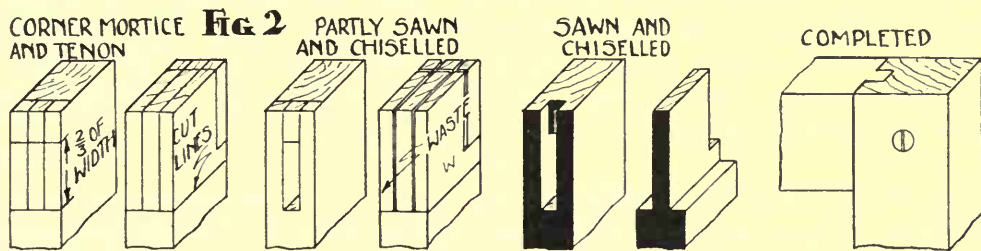
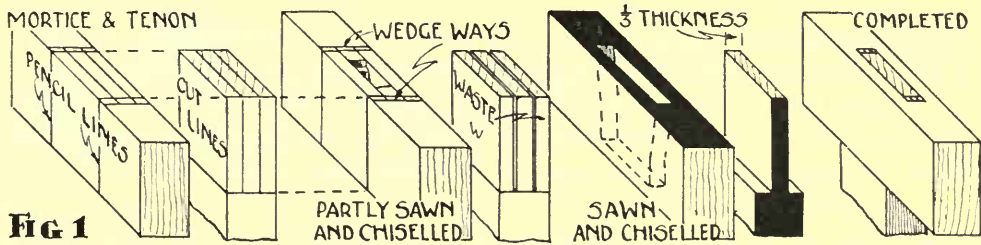

PEG - TRAIN SET

This little train set is both pleasing and satisfying to small children. The set is articulated and, although few examples of trucks are illustrated, many more will suggest themselves. Two points are of special importance : the coupling should be of $\frac{1}{4}$ " plywood and should fit **easily** over the peg, and it should be let in and screwed under the body of the truck (Figs. 2 and 3).

ENGINE (Fig. 1).—Prepare a base $8" \times 2\frac{1}{2}" \times \frac{1}{2}"$ and cut one end as in Fig. 6. Bore a $\frac{3}{8}"$ hole and glue in a 1" length of $\frac{3}{8}"$ dowel. Shape the boiler $2\frac{5}{8}" \times 1\frac{7}{8}" \times 1\frac{1}{4}"$. A chamfer $\frac{3}{8}" \times \frac{3}{8}"$ is put on the long top edges (Fig. 1). Now bore $\frac{3}{8}"$ and $\frac{1}{2}"$ holes in top for stack and valve and glue in short lengths of dowel. Make the cab $2\frac{1}{4}" \times 2\frac{1}{4}" \times 1\frac{1}{4}"$ and round-off the top. For the tender cut a piece $2\frac{3}{8}" \times 2\frac{1}{4}" \times 1\frac{1}{4}"$. Clean up all pieces and glue and screw to base.

COAL TRUCK (Fig. 2).—Prepare piece $6\frac{7}{8}" \times 2\frac{1}{2}" \times \frac{1}{2}"$. Cut one end as Fig. 6 and on the other end glue and screw a plywood coupling as Fig. 7. For the body cut two sides $5\frac{3}{4}" \times 1\frac{1}{4}" \times \frac{5}{16}"$ and two ends $2" \times 1\frac{1}{4}" \times \frac{5}{16}"$. Cut tongue and groove joints (Fig. 2). Glue and pin together. Clean up base and body and screw together.

MEAT VAN (Fig. 3).—Prepare a base as coal truck, and a block $5\frac{3}{4}" \times 2\frac{1}{4}" \times 1\frac{1}{2}"$. Put a $\frac{3}{8}" \times \frac{3}{8}"$ chamfer on long top edges of block, then screw to base.

"TANKER" (Fig. 4).—The base is similar to that of coal truck or meat van. From a block $5\frac{3}{4}" \times 1\frac{1}{2}" \times 1\frac{1}{2}"$ make a cylinder with a flat side (Fig. 4). Clean up and glue and screw to base, then glue and pin four wedge-shaped pieces to base, as in Fig. 4.

TIMBER WAGGON (Fig. 5).—Cut base as above, then shape two bracket pieces. One of these should be grooved to take the link piece as in Fig. 9. Glue and pin them to the base.

FINISH.—As the train is for very young children, a simple painted finish in bright colours, with no attempt at realism, is suggested.

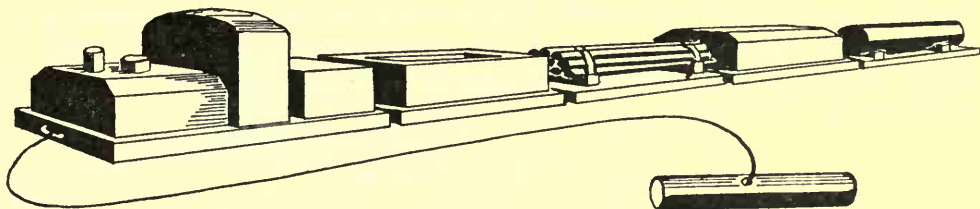

FIG 1 ENGINE

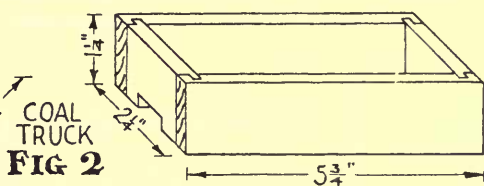
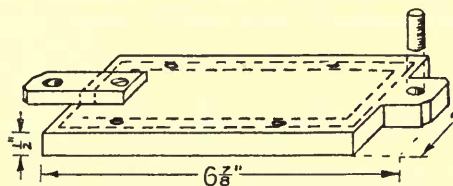
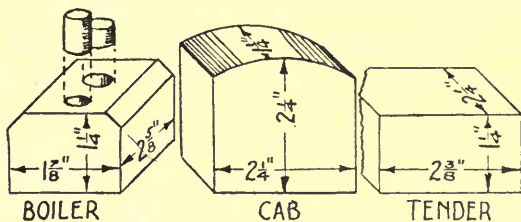
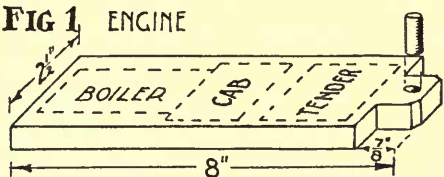

FIG 2 COAL TRUCK

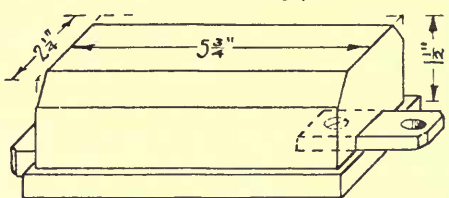
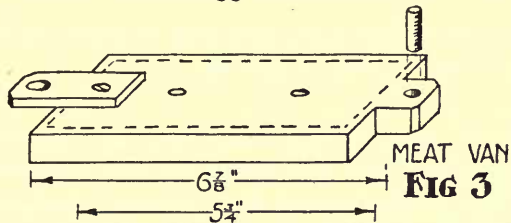

FIG 3 MEAT VAN

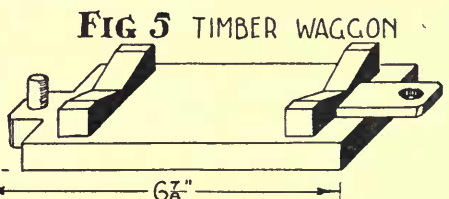
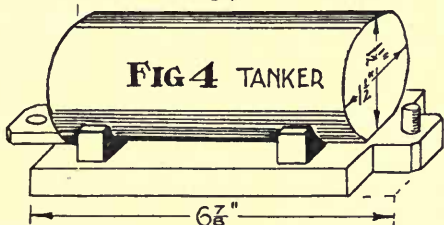

FIG 5 TIMBER WAGON

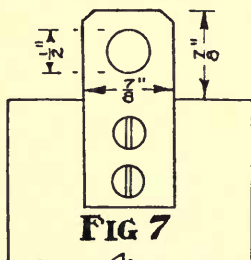
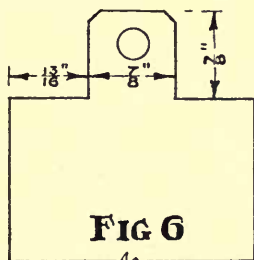

FIG 8 COUPLING

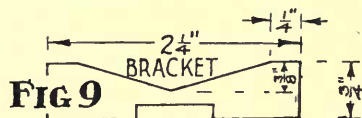

FIG 9 BRACKET

SIMPLE RAILWAY STATION

Like the peg-train set with which it is intended to be used this station is strong and yet pleasing in appearance. It is constructed in six pieces—a platform, two block “buildings” with seat and partition between, and the all-over roof.

CONSTRUCTION

PLATFORM.—Plane up a piece of deal to a finished size of $1' 6" \times 6" \times 1"$. Saw or plane off the wedge-shaped pieces to form the ramps at the ends (Fig. 2). Bore and countersink eight $\frac{3}{16}"$ holes for the screws to fasten “buildings” to base (Fig. 2).

BUILDINGS.—These are exactly alike and are $3" \times 3" \times 1\frac{1}{2}"$. Cut two grooves in one end of each to hold the seat and partition (Fig. 3). The horizontal groove is $\frac{1}{4}"$ wide, $\frac{1}{4}"$ deep and $\frac{1}{4}"$ from the bottom edge of the block. The vertical groove runs centrally from the top edge to the horizontal groove and is also $\frac{1}{4}"$ wide and $\frac{1}{4}"$ deep. Cut the horizontal groove first.

SEAT AND PARTITION.—The seat is $3\frac{1}{2}"$ long by $3"$ wide and $\frac{1}{4}"$ thick. The partition is $3\frac{1}{2}" \times 1" \times \frac{1}{4}"$.

ROOF.—This is $1' 0" \times 6" \times \frac{1}{2}"$. Along the centre line bore and countersink four $\frac{3}{16}"$ holes for screws to fasten roof to “buildings” (Figs. 1 and 4).

ASSEMBLY.—Clean up platform ready for painting and then seat and partition. Screw or nail seat to partition. Clean “buildings” and glue and screw one in position. Glue grooves and end of seat section, hold seat in groove and place second “building” in position, then screw down. Lastly clean up roof, glue tops of “buildings” and partition, and screw roof down.

FINISH by painting. Realism may be added by pasting suitable small advertisement labels from bottles and boxes to the “buildings.”

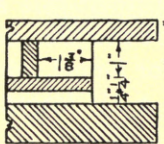
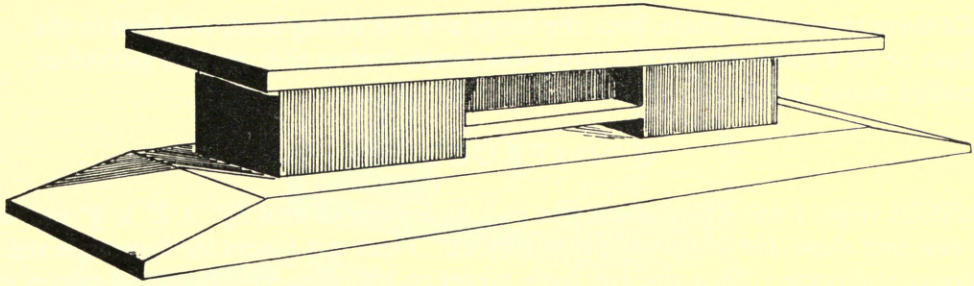

SECTION THROUGH CENTRE OF STATION

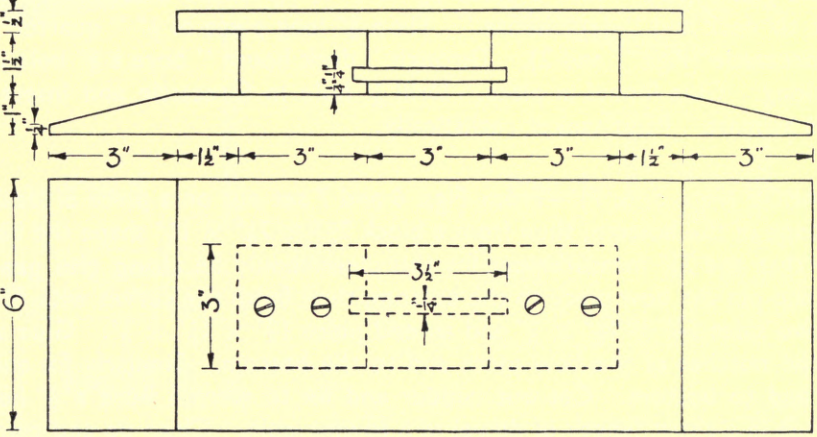

FIG 1

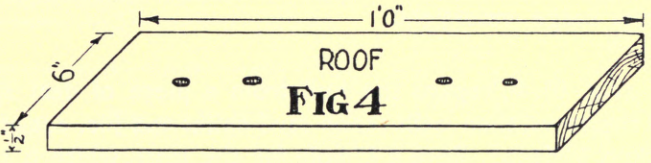
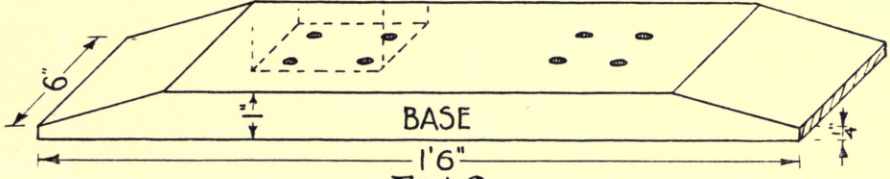
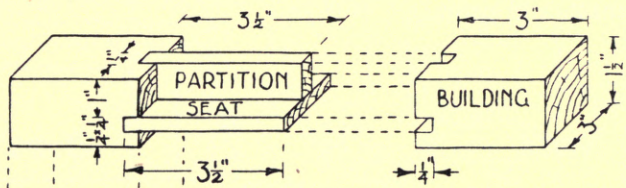

FIG 3



SMALL BOATS

Of these three small boats, two, the barge and the sailing boat, will float in the bath or on a pond, or like the water-line model tanker they may be pushed or pulled about the floor.

CONSTRUCTION

TANKER (Figs. 1 and 4).—Set out the hull on a piece of deal $7\frac{1}{2}'' \times 2'' \times \frac{3}{8}''$ and with tenon saw and chisel cut bows and stern (Fig. 2). Next cut pieces for forecandle and for deck house and poop. Glue and pin both pieces to hull (Fig. 4). Finish off curves with file and glasspaper. From a piece $1\frac{5}{8}'' \times 1'' \times \frac{7}{16}''$ shape bridge (Fig. 3), then glue and pin it to deck and "deck house." Fix a $\frac{3}{4}''$ long piece of $\frac{1}{2}''$ "quarter round" to deck and forecandle (Figs. 1 and 2). Through "deck house" bore a $\frac{3}{4}''$ hole for funnel, which is 2" long. Glue funnel in place. Drill $\frac{1}{8}''$ hole in forecandle and insert a $3\frac{1}{2}''$ length of $\frac{1}{8}''$ rod as mast. Paint tanker realistically.

BARGE (Figs. 5, 6, 7).—From Figs. 6 and 7 set out on a piece of deal $7\frac{1}{2}'' \times 2\frac{1}{2}'' \times \frac{1}{4}''$ the shape of the bottom, then from a block $2\frac{1}{4}'' \times 2\frac{1}{2}'' \times 1\frac{1}{2}''$ shape the bow piece (Fig. 7). Note that the $2\frac{1}{4}''$ measurement for this piece should be **along the grain** of the wood. Glue and pin the bow piece to the bottom, then finish the curves with file and glasspaper. Cut two sides $5\frac{1}{2}'' \times 1\frac{1}{2}'' \times \frac{3}{8}''$ and an end piece $1\frac{3}{4}'' \times 1\frac{1}{2}'' \times \frac{1}{2}''$. Glue and pin the sides into the notches of the bow piece and to the bottom. Similarly fix end piece between sides and to bottom. Cut out rudder and fix to stern. Bore a $\frac{3}{8}''$ hole in bow piece and glue in a short length of dowel as a towing pole. Clean up and paint inside and out with oil paint to make barge watertight.

SAILING BOAT (Fig. 8).—Prepare the hull from a piece of deal $3\frac{1}{2}'' \times 1\frac{3}{8}'' \times \frac{5}{16}''$. From plan mark out the bows, then with tenon saw, chisel and file, cut and finish curves. Set out and sink cockpit $\frac{1}{4}''$ deep. Bore a $\frac{1}{8}''$ hole for the mast, which is $1\frac{3}{4}''$ long. Clean up, glue in mast, and paint.

S M A L L L O R R I E S

The drawings on the opposite page show a fleet of small army lorries consisting of : (a) a "general purposes" lorry, (b) a mobile searchlight, (c) an ambulance, (d) a mobile gun, (e) a lorry for barrage balloon cylinders, and (f) a break-down lorry. All the bonnets, cabs and bases are similar, with the exception of base (e).

CONSTRUCTION

BASES.—Prepare five, each $6'' \times 2'' \times \frac{1}{2}''$.

BONNETS.—Plane up a piece of deal $12'' \times 1\frac{1}{2}'' \times \frac{3}{4}''$. Square one end. Measure $1\frac{1}{2}''$ from this end and square a line round the piece. Taper the end on three sides as shown in Fig. 5. Cut off along the squared line and clean up both sawn ends. Repeat for other bonnet pieces.

CABS.—Plane up a piece of deal $12'' \times 1\frac{1}{2}'' \times \frac{7}{8}''$. Bevel one side and slightly round-off the two corners to the section shown in Fig. 7. Finish one end square and measure from it $1\frac{3}{4}''$, then square a line round, saw off, and clean up both sawn ends. Glue and pin bonnet and cab to base as in Fig. 1.

COMPLETE individual lorries according to the following directions and the sketches at the top of the opposite page :—

- (a) To the lorry base glue and pin a piece $3\frac{1}{2}'' \times \frac{3}{4}'' \times \frac{5}{16}''$ along each side and another $\frac{1}{16}'' \times \frac{3}{4}'' \times \frac{5}{16}''$ across the end, as in Fig. 1.
- (b) Construct as (a) omitting end piece, then screw the 1" dowel rod searchlight (Fig. 3) to the base.
- (c) Base, bonnet and cab as in (a) and (b). The body is a block of wood $3\frac{3}{8}'' \times 1\frac{7}{8}'' \times 1\frac{5}{8}''$ rounded on the long top edges and glued and pinned to the base.
- (d) This is completed by the addition of the gun (Fig. 4).
- (e) For the base see Fig. 2. "Vs" made by two saw-cuts are added. Two cylinder supports—see Fig. 2 (inset)—should be glued to the base. The cylinders are short lengths of $\frac{3}{8}''$ dowel rod glued to one another and to the supports.
- (f) This is similar to (b) with the substitution of a crane block—see Fig. 6—for the searchlight.

FINISH.—"Camouflage" painting is the most suitable finish.

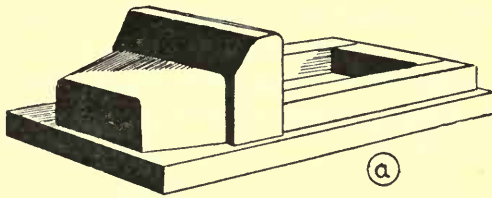

a

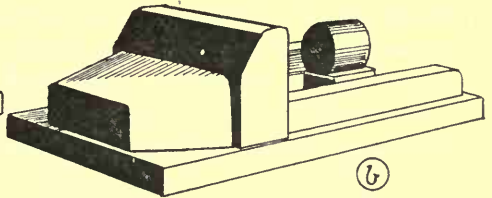

b

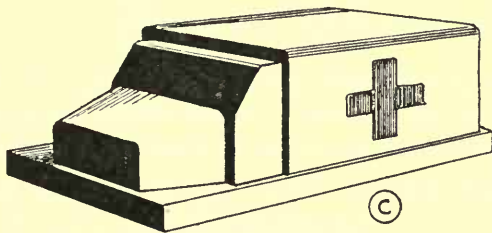

c

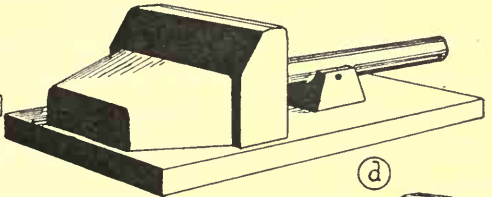

d

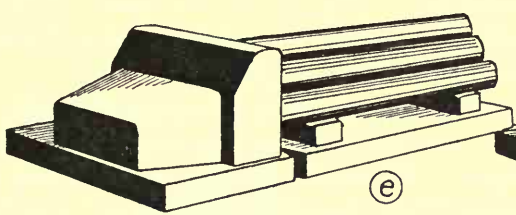

e

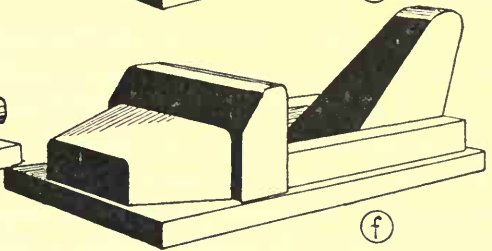

f

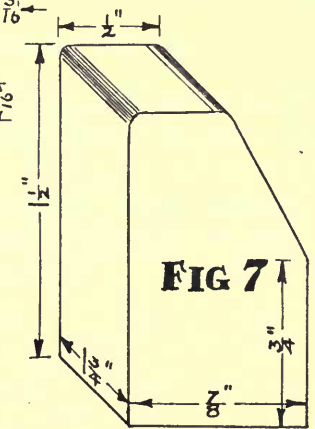
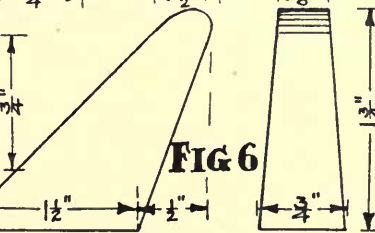
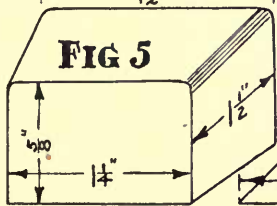
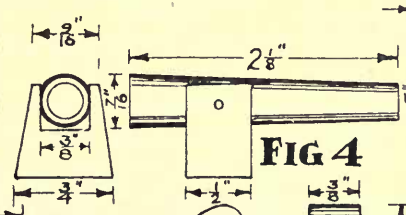
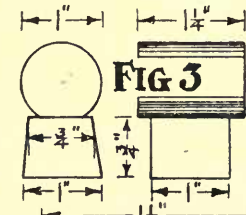
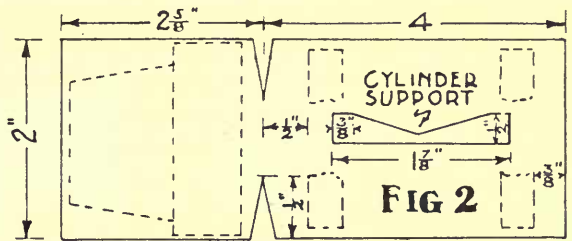
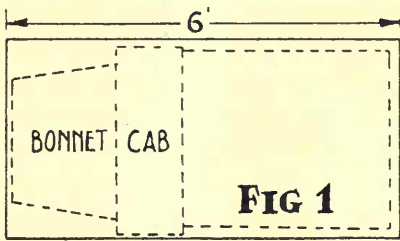

B R I C K S

Bricks are among the most popular of all children's toys. Suggestions for the construction of two kinds are given. Fig. 1 shows bricks $9'' \times 4\frac{1}{2}'' \times 3''$, i.e., approximately the size of those used in general building, while Fig. 4 shows "telescopic" bricks. The first set may also be made to serve the purpose of a simple jig-saw by the addition of a picture.

CONSTRUCTION OF BUILDING BRICKS

PREPARE.—(1) Two pieces of plywood to a finished size of $9'' \times 2\frac{1}{2}''$ for the sides. Note that the width of these pieces— $2\frac{1}{2}''$ —is approximate only and should be adjusted so that, together with the pieces used for top and bottom, the finished brick is $3''$ thick.

(2) Two pieces $9'' \times 4\frac{1}{2}''$ for the top and bottom. These may be of stout card if necessary.

(3) Two pieces of deal or thick plywood $4'' \times 2\frac{1}{2}'' \times \frac{5}{16}''$ for the ends. Note that these measurements also must be adjusted according to the thickness of the material used; the end of the finished brick should measure $4\frac{1}{2}'' \times 3''$.

It is most essential that all pieces of these bricks be cut and finished **square**.

Glue and nail the side pieces to the ends, test the resulting open box for squareness, then glue and nail down the top and bottom. When the glue is set, clean and paint the bricks. Half bricks should be constructed in similar manner but finished $4\frac{1}{2}'' \times 4\frac{1}{2}'' \times 3''$

TO ADD JIG-SAW PICTURE.—Build wall as in Fig. 1 but **flat on bench or floor**. Tie string round the whole to hold the bricks together. Glue the back of the picture, using fairly thin glue, place in desired position on bricks and, with a clean cloth, rub picture flat. Finally with a razor blade or very sharp knife carefully cut the picture along the joints of the bricks, then take off the string and rub down the edges of the picture on each brick.

CONSTRUCTION OF TELESCOPIC BRICKS

These bricks are made to fit inside each other as in Fig. 4.

To construct largest brick: From $\frac{3}{16}''$ plywood cut two pieces $9'' \times 8\frac{1}{8}''$, two pieces $8\frac{5}{8}'' \times 8\frac{1}{8}''$, and a piece $9'' \times 9''$. Glue and nail together as with the building bricks. To construct smaller bricks reduce the dimensions of each by $1''$ all round.

Paint each box with a separate colour.

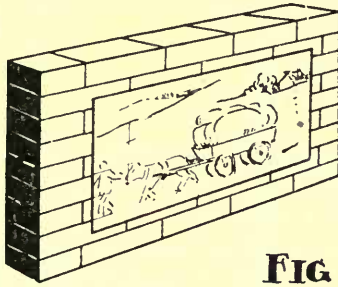

FIG 1

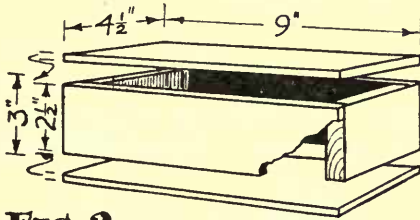
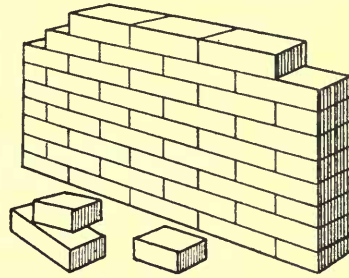

FIG 2

MEASUREMENT
SHOULD BE
ADJUSTED
ACCORDING
TO
THICKNESS
OF MATERIAL

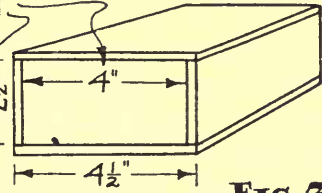

FIG 3

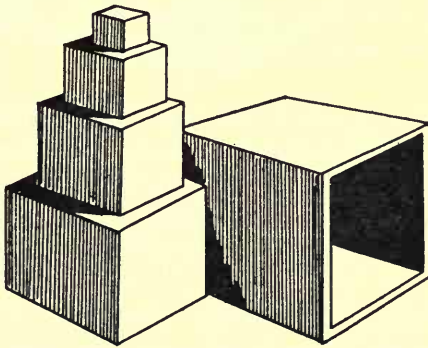

FIG 4

ISOMETRIC VIEW
OF LARGE BRICK
WITH OPEN END
DOWNWARDS AND
DIMENSIONED
FOR USE WITH
3/16 IN. PLYWOOD

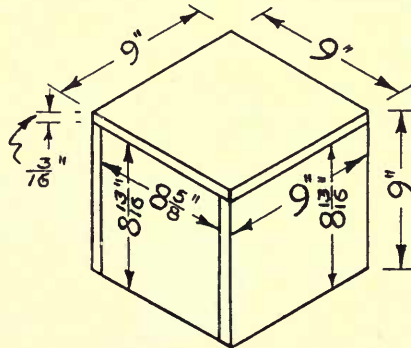

FIG 5

S I M P L E S E N S E - T R A I N I N G A P P A R A T U S

On the opposite page are illustrated four examples of sense-training apparatus, described below. All may be made more advanced by the addition of more pegs or "shapes."

C O N S T R U C T I O N

HAMMER PEGS (Fig. 1).—Prepare three pieces of hardwood, one $7\frac{1}{2}'' \times 4'' \times \frac{5}{8}''$, and two $6'' \times 4'' \times \frac{5}{8}''$. Draw a line parallel to, and $1''$ away from, each long side of the larger piece and three more parallel to the short sides, one $1\frac{3}{4}''$ from each end and one across the middle. Where the lines cross bore six clean holes of $\frac{1}{2}''$ diameter. Across the middle of each small piece cut a groove $\frac{5}{8}''$ wide and $\frac{1}{4}''$ deep. Clean up three pieces and glue and nail together, as Fig. 1.

TO MAKE PEGS round off a piece of hardwood $1' 11'' \times \frac{9}{16}'' \times \frac{9}{16}''$ so that it is just too large to enter the holes. Cut off six $3\frac{1}{2}''$ lengths. At each end of each peg make a saw-cut $1\frac{3}{4}''$ long, the cuts being at right angles to each other. Slightly bevel the end of each peg for easy entry.

THE MALLET is shaped from a piece of hardwood $2\frac{1}{2}'' \times 1\frac{1}{4}'' \times 1\frac{1}{4}''$ reduced on its inner face to $1\frac{3}{4}''$ long and rounded slightly from end to end of the outer face. The $\frac{1}{2}''$ diameter handle is glued, or glued and wedged, into the head.

PEG SHAPES.—The base is $9'' \times 4\frac{1}{2}'' \times \frac{1}{2}''$ with top edges slightly rounded. The three pegs are $2\frac{1}{2}''$ lengths of $\frac{1}{4}''$ dowel glued into holes in the base. Cut four squares from $\frac{1}{4}''$ plywood with sides of $1''$, $1\frac{1}{2}''$, $2''$, $2\frac{1}{2}''$, four circles with diameters of $1''$, $1\frac{1}{2}''$, $2''$, $2\frac{1}{2}''$, and four equilateral triangles with $1\frac{1}{8}''$, $1\frac{1}{2}''$, $1\frac{7}{8}''$, and $2\frac{1}{4}''$ sides. Bore $\frac{5}{16}''$ hole through each circle, square and triangle, then clean up and paint in different colours.

INSET.—The base is $5\frac{1}{2}'' \times 3'' \times \frac{3}{8}''$ deal. Cut piece of $\frac{1}{4}''$ plywood $5'' \times 2\frac{1}{2}''$. Set out rectangle, square and circle on plywood as in Fig. 3, then cut out with fine fretsaw. Glue and pin plywood to base. Bore $\frac{1}{4}''$ hole through each piece and glue in a $\frac{5}{8}''$ length of $\frac{1}{4}''$ dowel. Clean and paint.

POSTING BOX.—Make box with sides $6'' \times 3'' \times \frac{3}{8}''$ and ends $4\frac{1}{2}'' \times 3'' \times \frac{3}{8}''$, using any suitable joint. On bottom pin and glue piece of $\frac{3}{16}''$ plywood. Cut similar piece for lid and mark and saw out the five shapes shown in Fig. 4. On underside of lid glue four strips of $\frac{1}{4}''$ square beading to hold the lid in position. Make five hardwood prisms $2''$ long of sections similar to shapes of holes and so that they will easily pass through openings. Paint in bright colours.

FIG 1

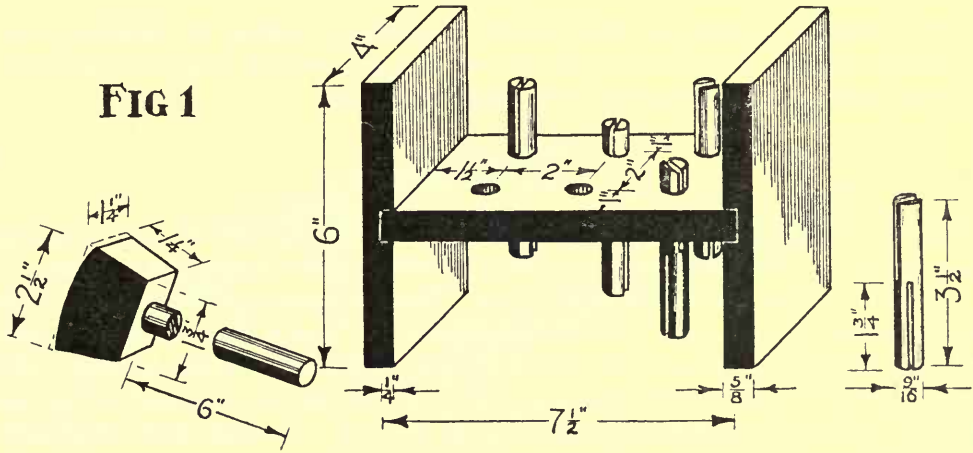

FIG 2

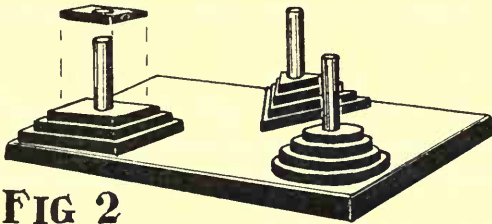

FIG 3

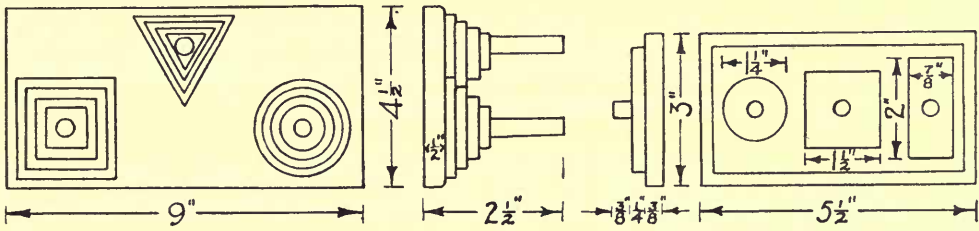
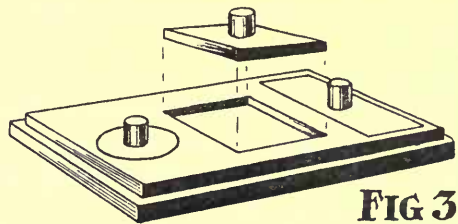
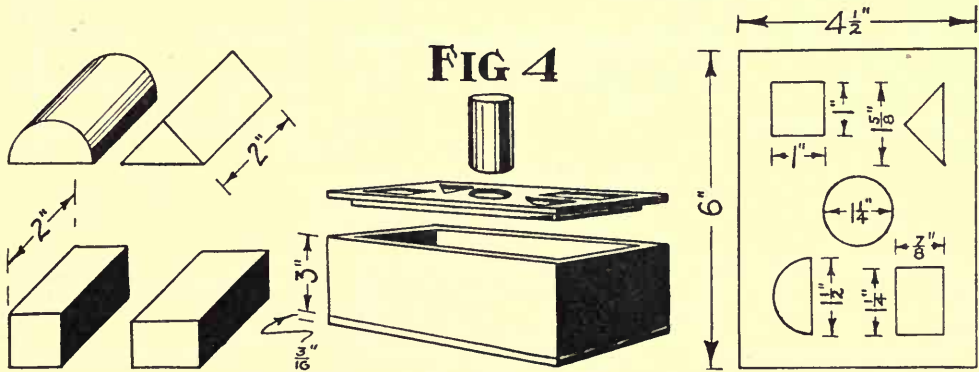

FIG 4



FLAT TROLLEY

This trolley provides an ideal means of transport, either of children or of other toys. It is light, low, easy to turn and pull around, and yet it is strong and capable of withstanding very rough treatment.

CONSTRUCTION

FRONT, SIDES AND BACK.—Prepare four pieces of deal to the measurements shown in Fig. 1. The front is narrowed to allow the slats forming the bottom to “run on” (Fig. 1). Mark out and cut the joints. Three suggestions for joints are shown at the foot of the opposite page; the one illustrated in Fig. 1 is the butt joint. Note that the length of the ends must be increased if either of the other joints is used. Fit joints together “dry.” Set out in the back piece the mortices for the ends of the slats, as in Fig. 3. Cut the mortices to a depth of $\frac{1}{2}$ ” (Fig. 3). Through both long sides bore and countersink four $\frac{3}{16}$ ” screw holes, each $\frac{3}{8}$ ” from the bottom edge, for screwing to slats (Fig. 1). Clean up arrises from top edges of all four pieces. Glue up square and flat.

BOTTOM.—Prepare five slats 1' $10\frac{3}{4}$ ” \times 2” \times $\frac{3}{4}$ ”. At one end of each cut a bare-faced tenon $\frac{1}{2}$ ” long, as in Figs. 2 and 5. Shape the other end of each piece, as in Fig. 1 (plan). Bore and countersink two $\frac{3}{16}$ ” holes in each piece $3\frac{3}{8}$ ” from the shaped ends for screwing to front rail.

BATTENS.—These are screwed under the slats to give extra support. On them are fastened the castors. Prepare two 1' 2” \times 2” \times $\frac{3}{4}$ ”. Through each bore nine $\frac{3}{16}$ ” screw holes, two at each end and one under each slat, as in Fig. 4.

ASSEMBLY.—When the glued-up framing has set, fit the slats, clean up, glue and screw in position. Bore a $\frac{3}{8}$ ” hole in each outside slat for a tow rope (Fig. 1). Screw on the battens and fix castors.

FINISH.—Clean up outside, paint and attach rope.

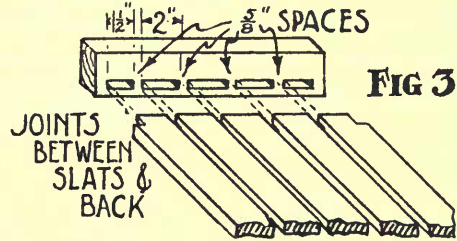
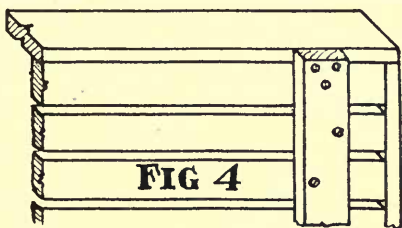
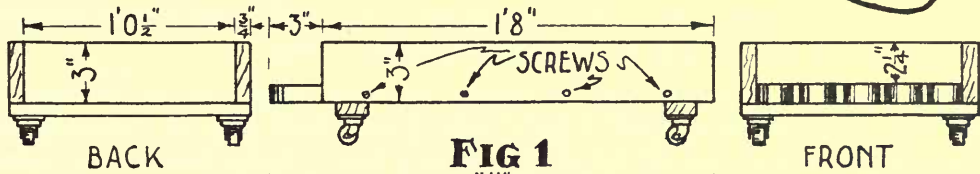
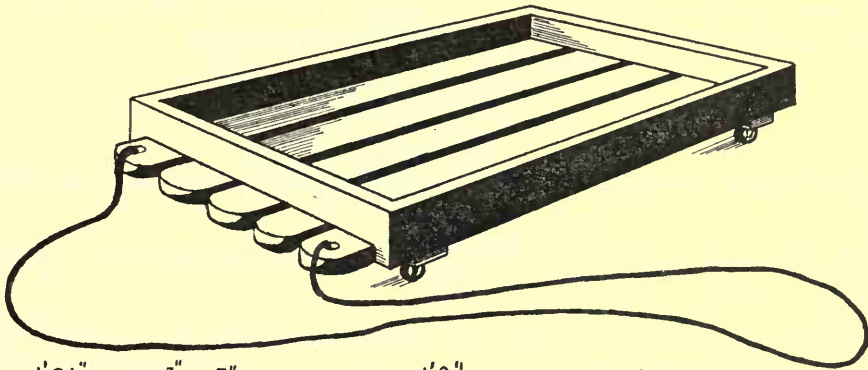

THREE SUGGESTIONS FOR JOINTS AT CORNERS

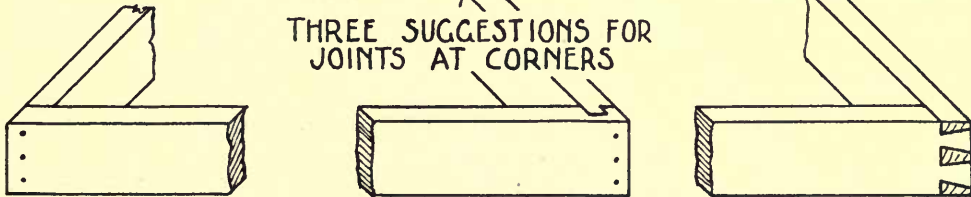

C R A D L E

For a small girl this is an ever-popular toy, being sufficiently long to accommodate most dolls. The headboard is $14" \times 11\frac{1}{2}" \times \frac{5}{8}"$, and the footboard $8\frac{1}{2}" \times 11\frac{1}{2}" \times \frac{5}{8}"$. They are dovetailed into the bottom which is $16\frac{1}{2}" \times 7" \times \frac{3}{8}"$. On each side four rails $16\frac{1}{2}" \times 1" \times \frac{5}{8}"$ are dovetailed into head and foot. Two rockers $11\frac{1}{2}" \times 2" \times 1\frac{1}{4}"$ are screwed to the bottom.

C O N S T R U C T I O N

HEAD.—Prepare headboard, square both ends, then mark out and cut to shape as in Fig. 1 (a).

FOOT.—Mark out and cut foot similar in shape and size to lower portion of head (Fig. 1 (b)).

BOTTOM.—Cut bottom to length and square ends as Fig. 2. At both ends of this mark out and cut "tails" for a common dovetail joint, then mark sockets for this in head and foot and cut out (Fig. 4). Fit joints together "dry."

RAILS.—Prepare eight side rails all exactly the same length as the bottom. Cut "tail" of a dovetail halving joint at both ends of each piece (Fig. 5). Carefully mark out the sockets for each tail on edges of head and foot. There should be a space of 1" between each rail. Number all joints so as to ensure quick and correct fitting when gluing up. Cut and fit the joints.

ROCKERS.—The two rockers should now be shaped, using bow saw and spokeshave, or chisel and spokeshave. Clean up the rockers, and if desired paint them.

ASSEMBLY.—Clean all inside faces and glue up commencing with head, foot and bottom. When gluing and fitting the rails begin with the top and work downwards. Square the cradle and allow the glue to set.

When the joints are "set" carefully clean up the outside of the cradle. Fix rockers to bottom with screws, first boring suitable holes.

FINISH.—Paint in bright colours.

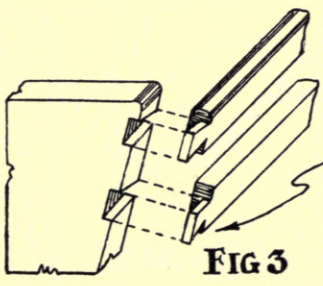
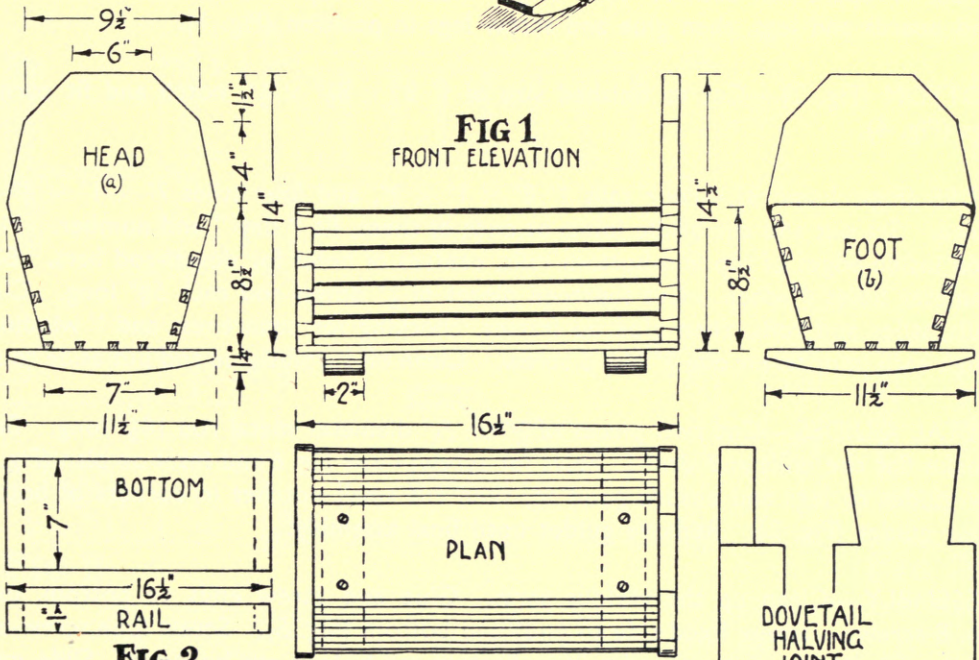
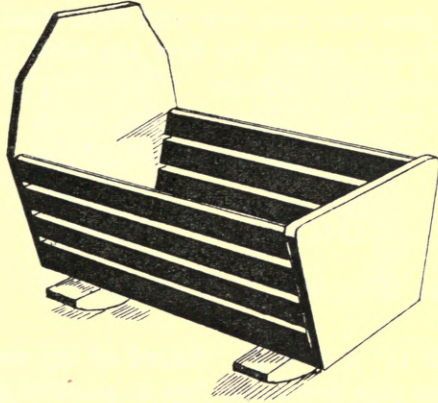

JOINTS OF RAIL WITH HEAD & FOOT AND OF HEAD & FOOT WITH BOTTOM

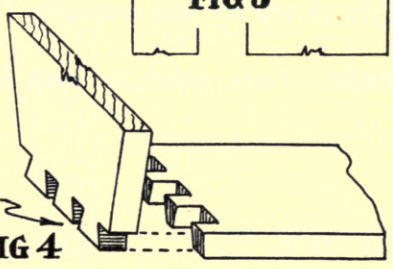

C O T S

The sketches opposite show two cots, one with fixed sides and the other with one fixed and one "drop" side. The first has solid ends $11" \times 7\frac{1}{2}" \times \frac{5}{8}"$ into which is housed the bottom $1' 2\frac{1}{4}" \times 7\frac{1}{2}" \times \frac{1}{2}"$. Two frames $1' 2\frac{3}{4}" \times 6\frac{3}{8}" \times \frac{5}{8}"$ are screwed to bottom and ends. The constructional details which follow are for the cot with the drop side.

CONSTRUCTION

ENDS.—Shape two pieces $10" \times 9" \times \frac{1}{2}"$ as in Fig. 1.

LEGS.—Prepare four each $11" \times 1" \times \frac{5}{8}"$. Round off top ends as in sketches. Clean up end boards and legs, then glue and screw legs in position (Fig. 1).

BOTTOM (Fig. 2).—Cut to finished size of $1' 8" \times 8\frac{1}{2}" \times \frac{1}{2}"$, notch and fit corners to legs (Fig. 4).

SIDES (Figs. 1 and 3).—Four rails $1' 8" \times 1" \times \frac{3}{4}"$, and four stiles $7" \times 1" \times \frac{3}{4}"$ are required. Set out and cut bridle joints at ends of these, fit "dry" and number. Mark out, on inside edges of top and bottom rails, centres of holes for dowel-rod bars. Bore $\frac{1}{2}"$ diameter holes $\frac{3}{8}"$ deep. Cut fourteen pieces of $\frac{1}{2}"$ dowel rod each $5\frac{3}{4}"$ long. Clean up rails, stiles and rods, then glue up frames, checking for squareness and "winding." Through each joint screw one $\frac{1}{2}"$ No. 5 screw. Clean off surplus glue and put aside to set.

METAL GUIDES.—Cut two pieces of $\frac{1}{8}"$ or $\frac{3}{16}"$ diameter metal rod $10\frac{1}{2}"$ long. Bend and make flat the ends and drill $\frac{1}{8}"$ holes for screws—see Fig. 6 and inset on plan (Fig. 1). Screw guides to legs and ensure good fit, then cut small notches in corners of bottom to clear guides (Fig. 2). Remove guides until final assembly.

ASSEMBLY.—Clean up the various parts. Glue and screw ends to bottom, using 1" No. 8 screws. Screw fixed side to ends and bottom (Fig. 5). Screw four screw-eyes into drop side, two on top rail and two on bottom rail **below cot bottom**. Slide metal guides through these and re-screw to legs. To hold up side, screw two small hooks and eyes on top rail and ends (Fig. 1).

FINISH.—Paint, polish, or stain and varnish cot as desired.

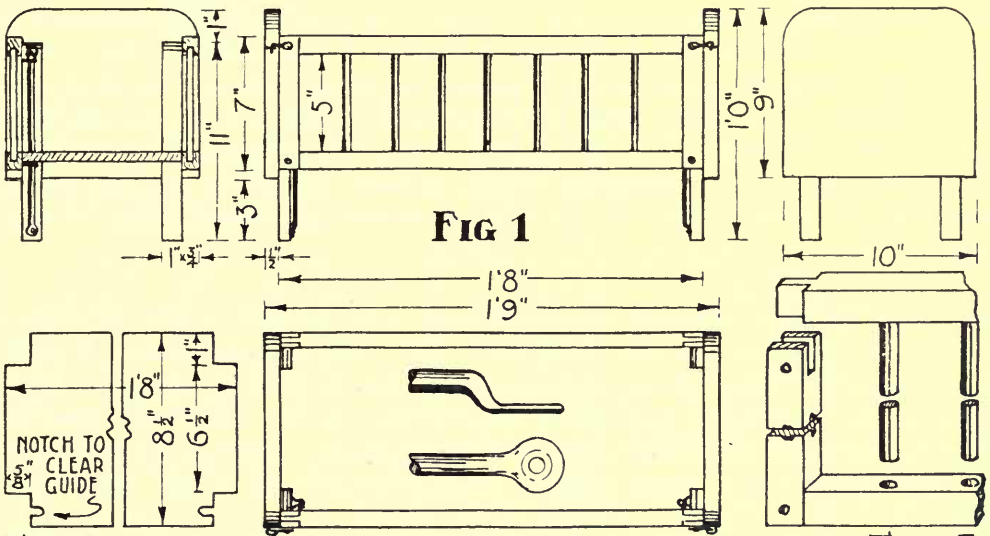
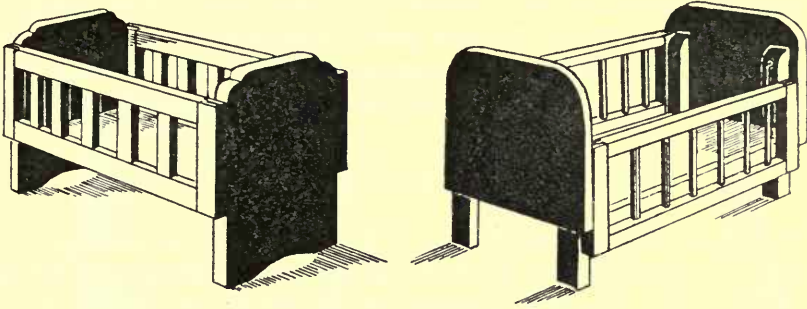

FIG 1

FIG 3

FIG 2

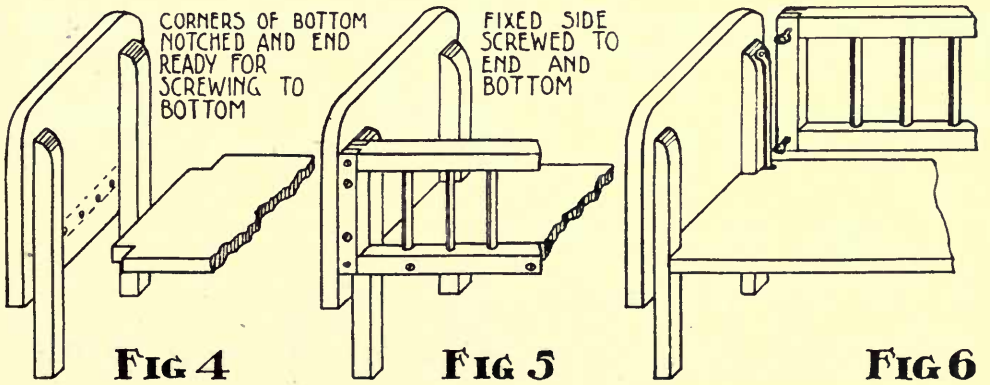

FIG 4

FIG 5

FIG 6

DRESSERS

To all girls the acquisition of a dresser is a great event. Two dressers are illustrated at the top of the opposite page. Both are well proportioned and compact, and in both there is an absence of hinges and awkward corners. Constructional details are given of the more difficult one only.

CONSTRUCTION

UPPER SECTION.—Cut two side pieces $1' 0" \times 3" \times \frac{5}{8}"$. At one end of each make a tongue $\frac{1}{4}" \times \frac{1}{4}"$; at the other end mark and cut dovetails, and then cut the two grooves $\frac{5}{8}" \times \frac{1}{4}"$ for shelves (Fig. 3). Now prepare the bottom $1' 4\frac{1}{2}" \times 3" \times \frac{5}{8}"$. Mark out dovetail sockets from the sides, cut and fit "dry." Prepare the top $1' 3" \times 3" \times \frac{5}{8}"$. On both ends of this make a tongue $\frac{1}{4}" \times \frac{1}{4}"$. Cut two shelves $1' 3\frac{3}{4}" \times 3" \times \frac{5}{8}"$. To form corner pieces plough a groove $\frac{1}{4}" \times \frac{1}{4}"$, as in Fig. 2, on each of two sides of a piece $1' 6" \times 1" \times 1"$. Cut off two portions of this, each 3" long and fit "dry" to sides and top. The remainder of this corner piece will be required later for the lower section. With a "round," or a gouge, shape inside curves of corner pieces, **leaving outside square** for ease of gluing up. Clean up inside faces, then glue and nail parts together, checking for squareness. Complete by adding plywood back $1' 4\frac{1}{2}" \times 1' 0\frac{3}{4}"$ glued and pinned, then set aside to set. In Fig. 6 are illustrated alternative joints for the top corners.

LOWER SECTION.—Prepare top $1' 4\frac{1}{2}" \times 6" \times \frac{5}{8}"$, bottom $1' 6" \times 6" \times \frac{5}{8}"$, two sides $8\frac{3}{4}" \times 6" \times \frac{5}{8}"$, and one shelf $1' 5\frac{1}{4}" \times 4" \times \frac{5}{8}"$. Cut stopped grooves in sides for shelf. Fit together "dry" as top section. Plough two grooves $\frac{1}{4}"$ wide and $\frac{3}{8}"$ deep in bottom, and two more $\frac{1}{4}"$ wide and $\frac{3}{8}"$ deep in top (Fig. 4). The deeper grooves are to allow for insertion of doors after carcass has been glued up. Clean up and glue together, adding plywood back as in upper section. Make a plinth $1' 5\frac{5}{8}" \times 5\frac{1}{8}"$ out of $1" \times \frac{5}{8}"$ material.

Clean up both sections, round the corners and screw together. Screw on plinth.

Cut two pieces of $\frac{1}{4}"$ plywood $8\frac{5}{8}" \times 8\frac{5}{8}"$ for doors. Bore two $\frac{3}{4}"$ holes or fit two small handles, then insert into grooves.

FINISH as desired.

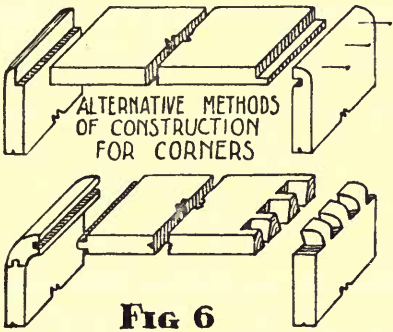
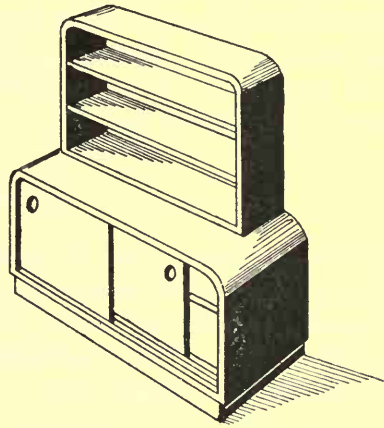
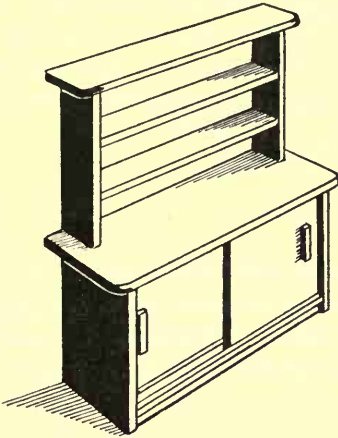

FIG 6

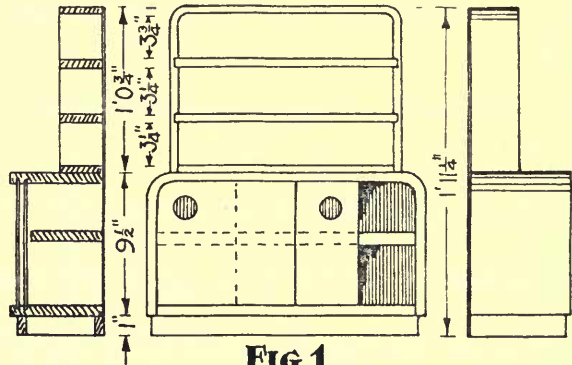

FIG 1

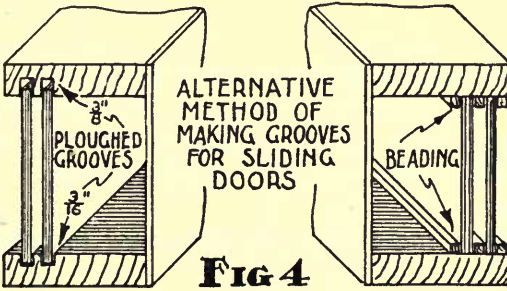

FIG 4

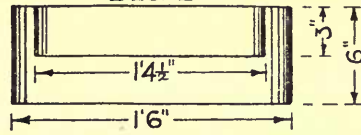
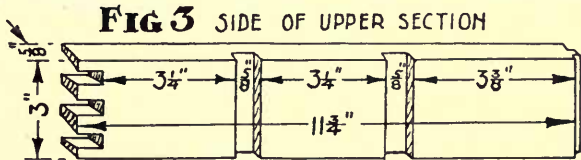
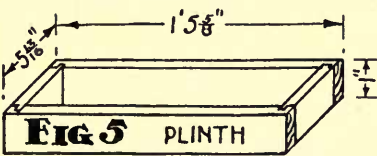
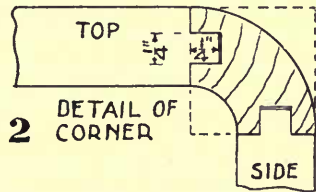

FIG 2

DETAIL OF CORNER



F U N B O A T

The Fun Boat is a very popular toy with children. Not only can they "swing high and swing low" without fear of overturning, but they can also make the boat spin around. The slats across the bottom prevent any trapping of toes as the boat rocks. The hand-rail in the centre is so placed that it gives good gripping and pulling exercise.

CONSTRUCTION

ROCKERS.—On two pieces of sound board—preferably hardwood— $3' 0" \times 11" \times \frac{7}{8}"$ mark out the curve of the rocker (Fig. 1) and set out on each piece the four mortices for the seats and two for the bottom rails (Figs. 1 and 6). Working from both sides cut out the mortices. To cut the curve fasten both sides together with the mortices, registering so that both pieces are exactly alike.

SEATS.—These are $12" \times 7" \times \frac{3}{4}"$ and two are required. Mark out and cut tenons as in Fig. 2.

BOTTOM RAILS.—Two are required each $12" \times 1\frac{1}{2}" \times 1"$. Mark out and cut tenons as in Fig. 6.

SLATS.—Cut four each $1' 10" \times 2" \times \frac{3}{8}"$.

HAND-RAIL.—This is $1' 1" \times 1\frac{1}{2}" \times \frac{3}{4}"$. It should be rounded on both edges.

HAND-RAIL SUPPORTS.—These are $1' 2\frac{1}{2}" \times 1\frac{3}{4}" \times \frac{3}{4}"$ and are cut as shown in Fig. 4.

ASSEMBLY.—Fit boat together "dry" to ensure correct fit of all parts—then take apart. Cut "wedge-ways" in the tenons, ease outside of mortices to allow for spread caused by insertion of tenons, then clean up all parts except outsides of rockers. Glue tenons and mortices and then assemble rockers, seats, and bottom rails, driving in the wedges and checking the boat for squareness.

When glue has set hard, drill a hole at the end of each slat and screw in position (Figs. 3, 5 and 7).

Glue and screw the hand-rail supports to the boat (Fig. 5).

Finally clean up where necessary, removing all sharp edges, and finish as desired.

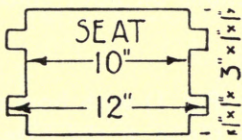
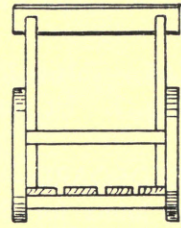
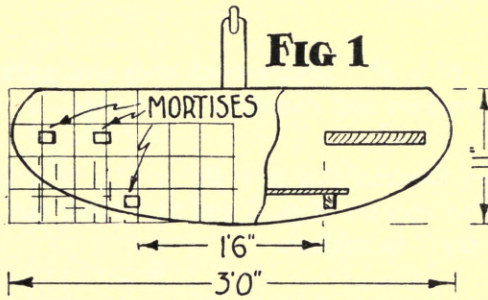
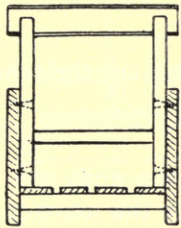
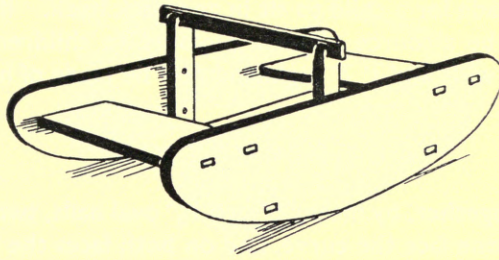

FIG 2

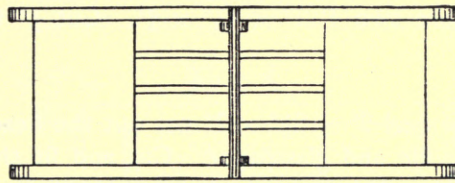

FIG 3

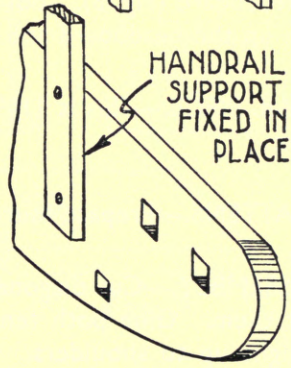
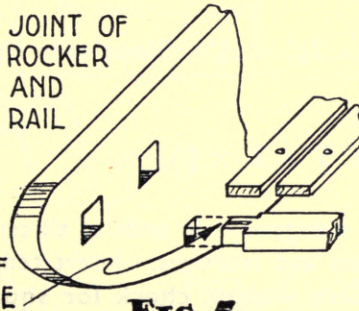
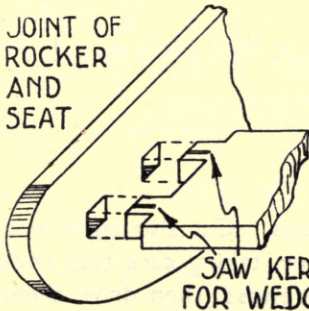
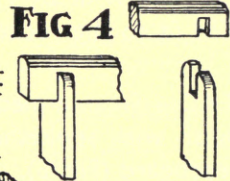

FIG 5

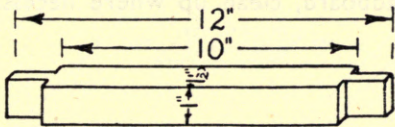

FIG 6 BOTTOM RAIL

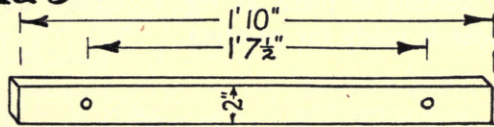

FIG 7 SLAT

DUCK BOAT

The Duck Boat is made for a child to sit in and rock itself. If well constructed and finished it will be a source of great pleasure to children for many years. It is 2' 4" long, 1' 1" wide and 1' 7" high, and may be made of hard or soft wood.

CONSTRUCTION

ROCKERS.—Fasten together, by means of two $1\frac{1}{2}$ " oval nails, two boards 2' 4" \times 10" \times $\frac{3}{4}$ ". From Fig. 1 mark out on one face the curve, and on both faces the four mortices. Working from both sides, cut the mortices, then with bow saw and spokeshave cut and finish the curve. Separate the rockers.

SEAT.—This is 1' 1" \times 8" \times $\frac{3}{4}$ ". Square both ends and mark out and cut the tenons as in Fig. 2. Fit seat to rockers and round-off front edge.

HEADBOARD.—When finished this is 1' 0 $\frac{3}{4}$ " \times 5" \times $\frac{3}{4}$ ". Square the ends and cut half-lap joints for fitting to rockers (Figs. 3 and 5). Mark out and cut the mortice for the head (Fig. 3). Fit "dry" to rockers.

BOTTOM RAILS.—Prepare two 1' 1" \times 1 $\frac{1}{2}$ " \times $\frac{3}{4}$ ". Cut $\frac{1}{2}$ " tenons on both ends of each and fit to the rockers.

HEAD.—From a piece of deal 9" \times 8 $\frac{1}{2}$ " \times 2" cut out the head (Fig. 1) with bow saw and finish with spokeshave, file and glasspaper. Cut and fit the tenon at the base to the headboard (Fig. 6). Bore a $\frac{3}{4}$ " hole in the head, as Fig. 1, for a piece of $\frac{3}{4}$ " round rod. Clean up the headboard and glue and screw head in position (Fig. 6). Glue in the rod.

TAIL PIECE.—This is 11 $\frac{1}{4}$ " \times 2 $\frac{1}{2}$ " \times 1 $\frac{1}{2}$ ". Shape as in Fig. 4, then clean up and screw to seat.

BATTENS.—Prepare four 1' 5" \times 2" \times $\frac{3}{8}$ ".

ASSEMBLY.—Cut diagonal wedgeways in ends of all tenons. Cut also eight wedges to fit them. Glue both tenons and mortices. Insert tenons, taking care that rockers are tight up to shoulders. Glue wedges, **check for squareness**, then drive them in. Screw battens in place, as Fig. 1. Screw down headboard, clean up where necessary, and boat is ready for painting.

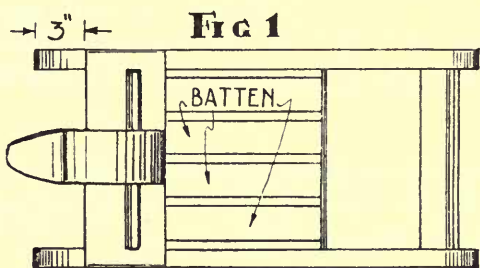
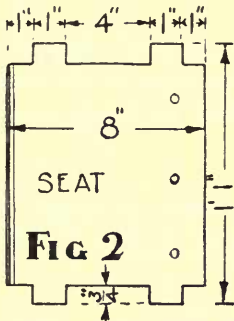
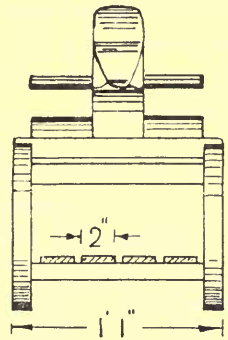
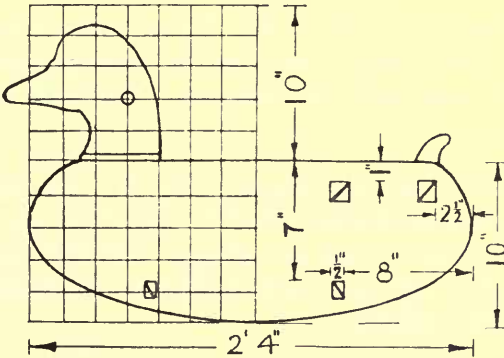
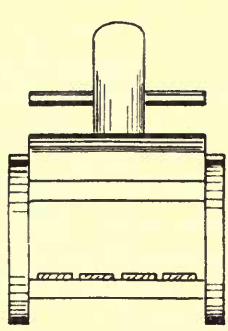
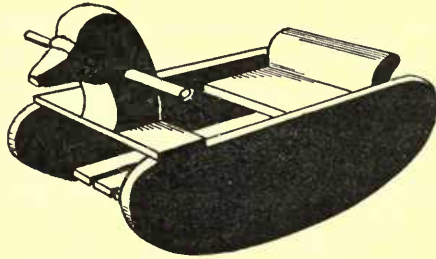
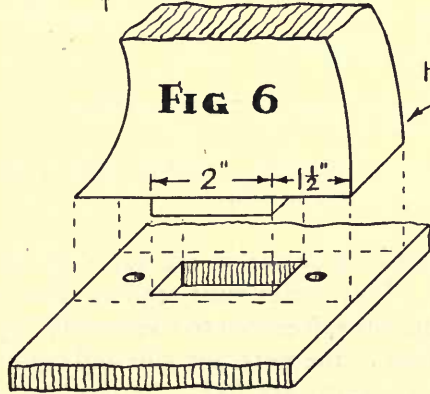
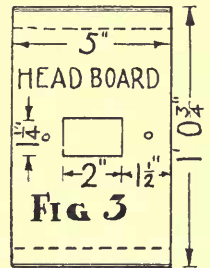

FIG 1



HEAD

FIG 6

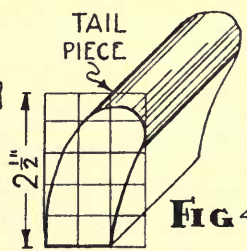

FIG 4

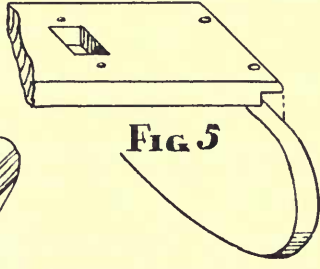

FIG 5

SHOWING JOINT BETWEEN SIDE AND HEADBOARD

FLYING DUCK

This duck has, because of its movement and the "click-clack" of its wings, proved a fascinating toy to very many children. As the duck is rocked the wings are made to rise and fall by means of a plunger (Figs. 1 and 6).

A simple duck without the wings is illustrated in Plate VII. It has two bottom rails which carry footrests. Otherwise its construction is as set out below. The head shows the effect of greater attention to shaping.

CONSTRUCTION

ROCKERS.—These are $2' 2" \times 9\frac{1}{2}" \times \frac{3}{4}"$. Set out and cut the $\frac{1}{4}" \times \frac{1}{4}"$ tongue on top edge of each (Fig. 2). Now "pair" the sides, fix together with "G" clamps or panel pins, and set out curve, wing slots and mortices. Cut slots and mortices, then shape and finish curve.

RAILS.—The three cross rails are shown in Fig. 3. The back and plunger rails are each $2" \times 1"$ in section and the bottom rail $2" \times 1\frac{1}{2}"$. Cut the three and fit "dry" to the rockers. Cut wedgeways in back and plunger rails and in mortices of bottom rail. Clean up rockers and rails, then glue up and drive in the wedges. Carefully check for "squareness" during the assembly.

SEAT (Fig. 4).—This is $1' 8" \times 6" \times \frac{3}{4}"$ and has both ends square. Plough two grooves $\frac{1}{4}"$ wide and $\frac{1}{4}"$ deep, as in Fig. 4, for the tongues on the top edges of the rockers. Cut the mortice for the head (Fig. 7) and bore four $\frac{3}{16}"$ screw holes for fixing head and tail. Fit seat "dry."

WINGS (Fig. 5).—From two pieces of $\frac{1}{4}"$ plywood $10\frac{1}{2}" \times 8"$ shape the wings. Bore the two $\frac{3}{8}"$ holes as shown. Groove and glue on to each a piece $5" \times 2" \times \frac{3}{4}"$ (Fig. 5). Fasten a piece of strip lead to each, as in Fig. 1.

HEAD.—Shape the head as Fig. 1 from a piece of deal $7" \times 8" \times 2"$. Cut tenon on base (Fig. 7). Fix to seat board with screws and wedges.

TAIL (Fig. 7).—Shape this from deal $4" \times 2\frac{1}{2}" \times 1\frac{1}{2}"$, and screw in position.

PLUNGER (Fig. 6).—Cut a disc $2\frac{1}{2}"$ diameter and $\frac{1}{2}"$ thick. In the centre bore a $\frac{1}{2}"$ hole, into which glue and wedge a $6"$ length of $\frac{1}{2}"$ dowel rod.

ASSEMBLY.—To hold wings in position, bore two $\frac{3}{8}"$ holes in the top edge of the rockers and across the wing slots, Fig. 1 (section). These holes must register with those in the wings, which should be elongated to allow the wings freedom to rise and fall (Fig. 5). Now drop the plunger in position, insert the wings in the slots, and glue and tap in the dowels. Glue and screw down the seat board on which are fixed the head and tail. Finally clean up and paint.

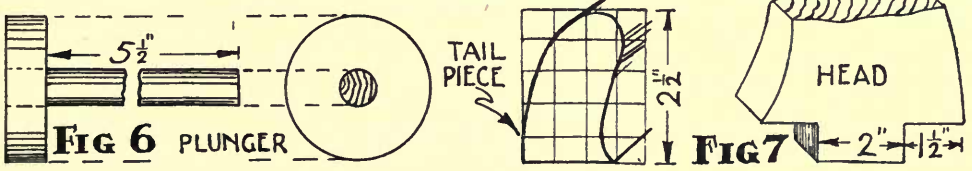
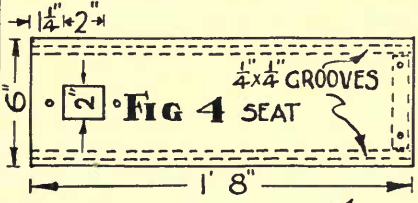
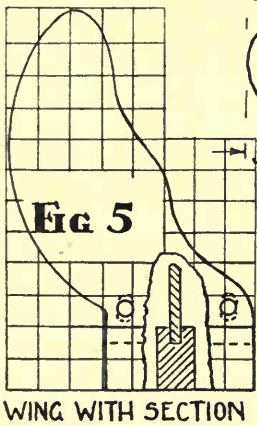
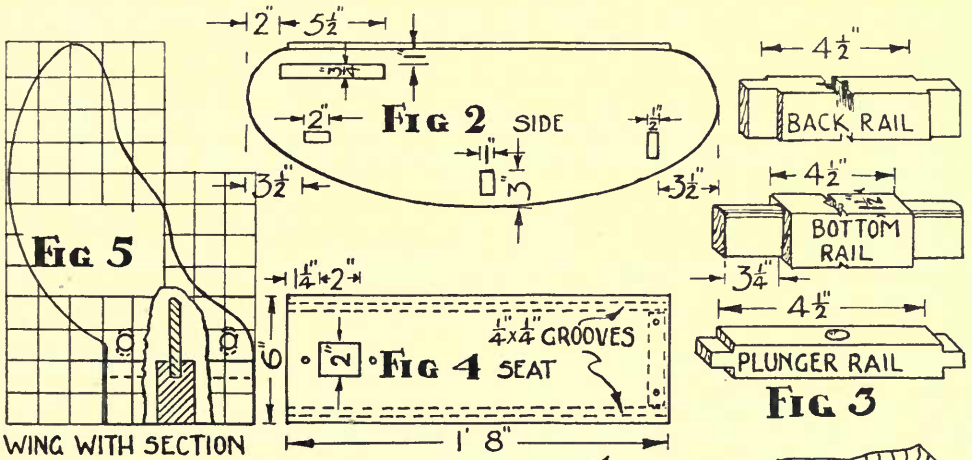
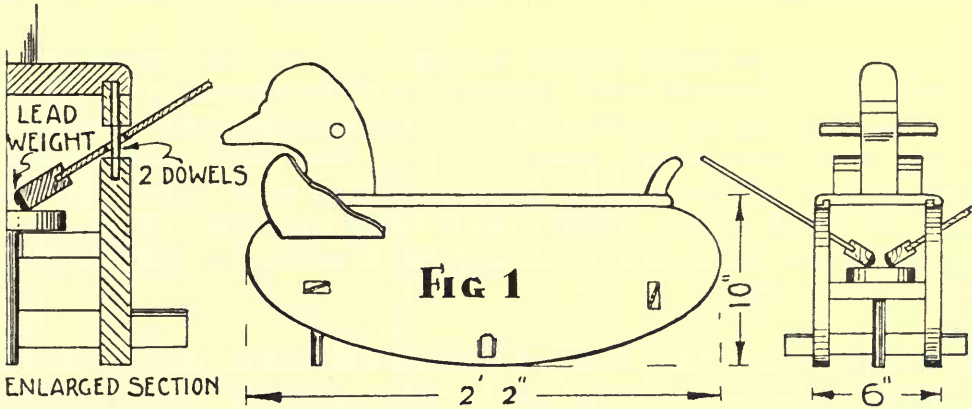
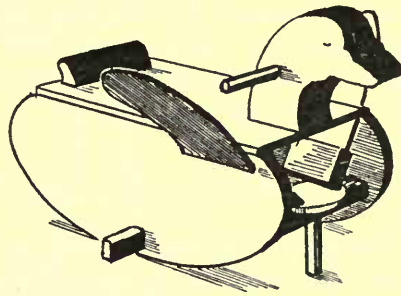

“TISHY”

“Tishy” has been included because it shows how scrap material can be used to good effect. In this case an old “bent-wood” chair has been utilised in the construction of a rocking horse: the legs of the chair are adapted as the four legs, with three pieces of board for the body.

CONSTRUCTION

LEGS.—From an old “bent-wood,” or similar chair, cut four legs about 1' 4" long. Through the top of each bore and countersink two $\frac{1}{4}$ " screw holes (Figs. 1 and 2).

BODY.—Prepare two pieces of deal 1' 6" \times 3 $\frac{3}{4}$ " \times 1". Mark out and cut grooves for legs (Fig. 5), making the width of the grooves equal to the diameter of the legs and the depth equal to one half of the diameter. Fit legs and number joints. Now through sides bore and countersink six $\frac{1}{4}$ " holes as in Fig. 2. These are for screws to hold head and body together and should not be opposite each other or the screws may foul when inserted. Round-off corners. On one end of centre piece shape tail (Fig. 4). Glue and screw the three pieces together with 1 $\frac{3}{4}$ " No. 10 screws. Level-off the joints and remove the sharp edges.

ROCKERS.—From a board 2' 6" \times 8" \times 1" cut two rockers (Fig. 3). Pin rockers together and spokeshave to finished curve. Before separating rockers mark out and cut joints. Two suggestions for joints are given in Fig. 7. Cut joints at ends of legs, fit and number to rockers.

HEAD.—By means of squares set out the head (Fig. 6) on a piece of wood 11" \times 6" \times 1". Cut and finish. Through head bore a $\frac{3}{4}$ " hole for a bar (Figs. 6 and 9). Glue and screw head in position.

SADDLE PIECE.—Shape this as in Fig. 8. Bore three $\frac{3}{16}$ " screw holes as indicated and screw to body.

ASSEMBLY.—Remove varnish or paint from tops of legs to allow glue to adhere. Glue and screw legs into grooves, taking care to see that bottom joints fit into or over rockers. Glue and screw rockers to legs. Clean off surplus glue and allow finished horse plenty of time to “set.” Clean up and paint as desired.

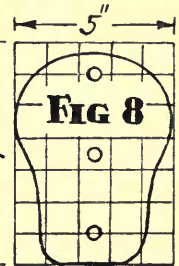
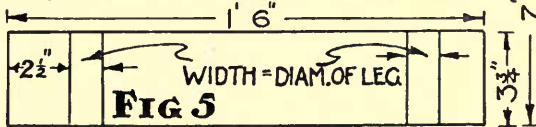
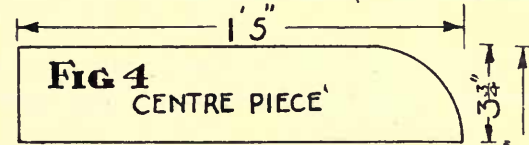
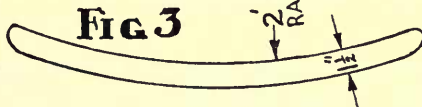
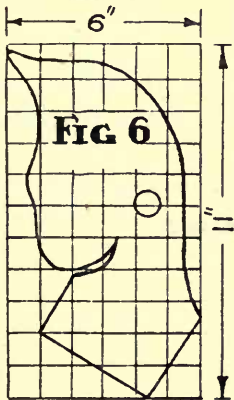
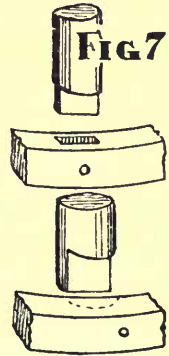
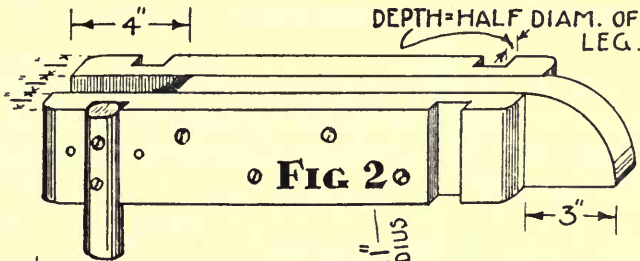
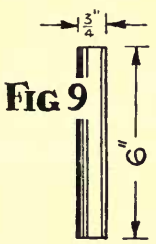
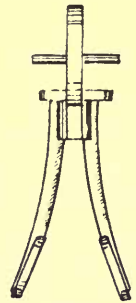
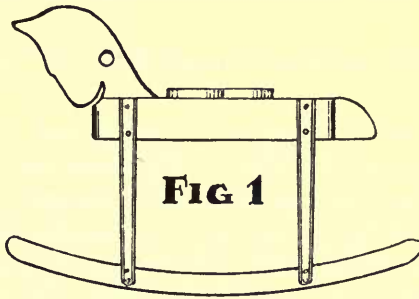
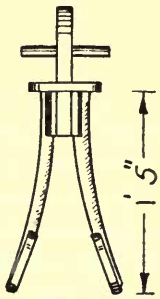
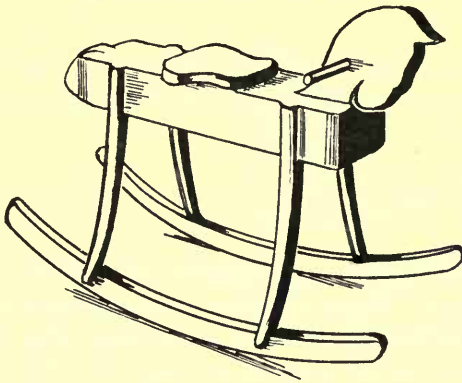

SMALL ROCKING HORSE

This small rocking horse is very pleasing both in appearance and as a toy. Designed for use by very young children, it loses some of its appeal if the suggested dimensions are increased.

CONSTRUCTION

SEAT (Fig. 2).—Make from one piece of deal $1' 3" \times 7\frac{1}{2}" \times 1\frac{1}{4}"$. Square both ends and from Figs. 1 and 2 set out the mortices. **Note that the mortices are not square through the seat : they are splayed at the same angle as the legs (Fig. 1).** Working from both sides, cut mortices. Enlarge for wedges on top side (Fig. 4). When mortices are cut shape the seat (Fig. 2) with bow saw and spokeshaves.

ROCKERS (Fig. 5).—Cut two from a board $2' 8" \times 7" \times \frac{3}{4}"$.

LEGS (Fig. 3).—These are $8\frac{1}{2}" \times 2" \times 2"$. While still "in the square" cut tenons at one end and bridle joints at the other. The thick line in Fig. 6 shows the correct angle for the shoulder. Taper the legs while still "square" from $2" \times 2"$ at the bottom to $1\frac{1}{2}" \times 1\frac{1}{2}"$ at the top. Fit legs to seat and number the joints. The construction of a plywood template of the angle between seat and leg to ensure that all legs are at the same angle to the seat will prove well worth while. Fit legs to rockers, then round them off with the plane, finishing with glasspaper.

HEAD (Fig. 7).—Set out this by "squares" on a piece of deal $10" \times 7" \times 2"$. It may be left rectangular in section, or it may be simply modelled, as in Plate III. Cut, finish and fit the head "dry" to the seat, even putting in both screws. When satisfied as to the fit, remove the head.

TAIL (Fig. 8).—Shape this from piece of deal.

ASSEMBLY.—Clean up all parts, then glue and wedge legs to seat, carefully checking angles between legs and seat. When glue has set, glue and screw on the head and tail.

FINISH.—If well made, a good finish for this horse is to leave it "in the white" and wax polish it. Painting in two suitable colours is also recommended.

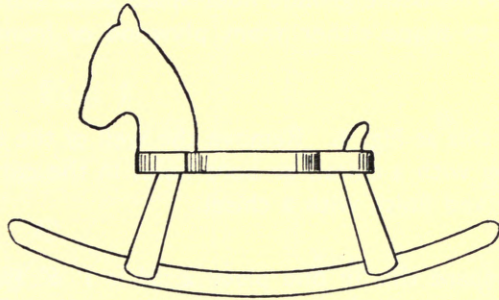
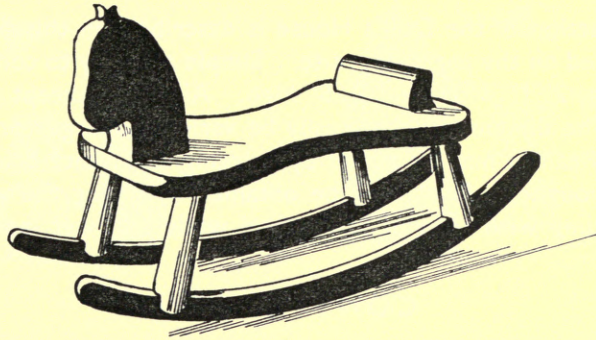

FIG 1

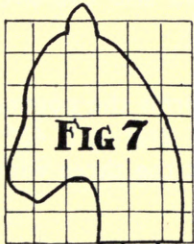
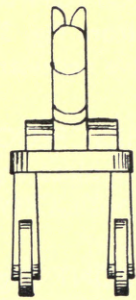
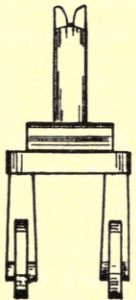

FIG 7

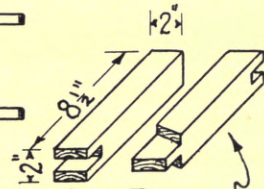
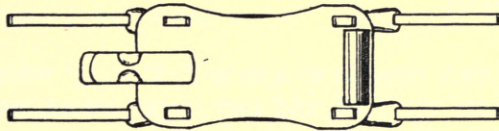

FIG 3
LEGS — SQUARE
ROUND & TAPERED

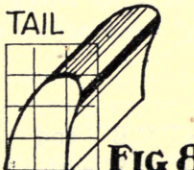

FIG 8

CORRECT ANGLE
OF SHOULDER

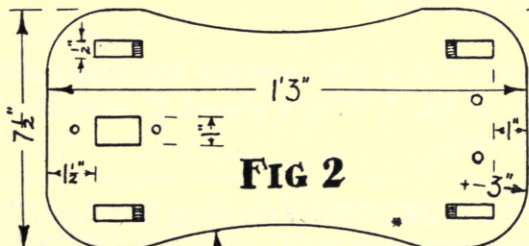
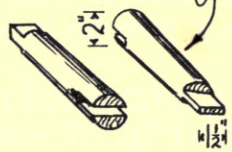

FIG 2



MORTISE
ENLARGED
FOR WEDGES

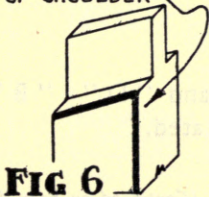

FIG 6

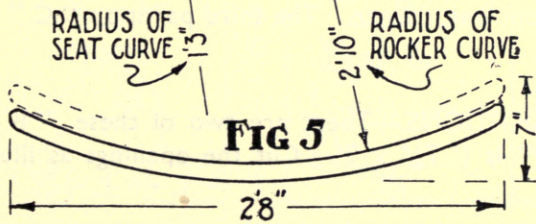

FIG 5

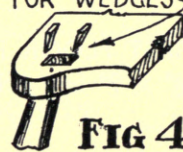

FIG 4

DOLL'S HOUSE

The construction of the Doll's House is described on this page and overleaf, and illustrated on the pages opposite. Simple and easy to construct, the house is 2' 5" long, 2' 1" wide, and 2' 5" high. All parts except the windows are $\frac{3}{8}$ " thick. The dimensions may easily be varied if a larger or smaller house is required. Realism may be added by painting to imitate brickwork, stone or slate, or a roughcast finish may be obtained by giving the walls a coating of glue, sprinkling with sand or fine gravel while still wet, and painting white.

CONSTRUCTION

BOTTOM BOARD.—This is the ground floor space piece and is 2' 5" \times 2' 0 $\frac{3}{4}$ ". Mark out from Fig. 3 and cut to shape either from plywood or from several boards jointed to give necessary width.

FIRST FLOOR.—Cut this as Fig. 4. Remove the well of the stairs by boring out the centre piece and finishing with a chisel, or bore holes in the corners and cut round the well with a keyhole saw and finish with a chisel.

FRONT (Fig. 5).—Prepare this in one piece 2' 5" \times 1' 6" (jointed). Mark out and cut both window openings in similar manner to the stair well, and also the circular opening for the front porch.

BACK (Fig. 6).—The back consists of a strip 2' 5" \times 1 $\frac{1}{2}$ " which forms the portion of the wall immediately under the roof, and two larger pieces, one 1' 2 $\frac{1}{8}$ " \times 1' 4 $\frac{1}{2}$ " and the other 1' 2 $\frac{5}{8}$ " \times 1' 4 $\frac{1}{2}$ ", which will be made to swing open. Cut the three window openings and lastly the door opening.

ENDS (Fig. 7).—Cut two, 2' 4" \times 1' 8", with one end square and the other triangular. A half elevation is shown in Fig. 7. Cut a groove $\frac{3}{8}$ " wide and $\frac{3}{8}$ " deep across each piece 9" from the square end.

GROUND FLOOR PARTITIONS.—There are three partitions, "A," "B" and "C." "A" is 1' 7 $\frac{1}{4}$ " \times 9" with one opening 6" \times 2 $\frac{1}{2}$ ". Partition "B" is 1' 1 $\frac{3}{4}$ " \times 9" with a piece 6" \times 2 $\frac{1}{2}$ " removed from one corner. The third partition "C" is also 1' 1 $\frac{3}{4}$ " \times 9" with an opening in it 6" \times 4".

FIRST FLOOR PARTITIONS.—There are two of these, "B" and "D." "B" is 1' 1 $\frac{3}{4}$ " \times 9" and "D" is 1' 7 $\frac{1}{4}$ " \times 9". Cut the openings as illustrated.

(Continued on Page 46)

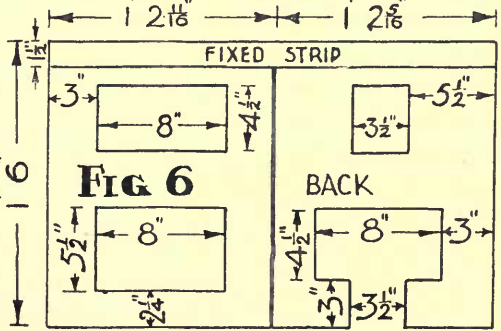
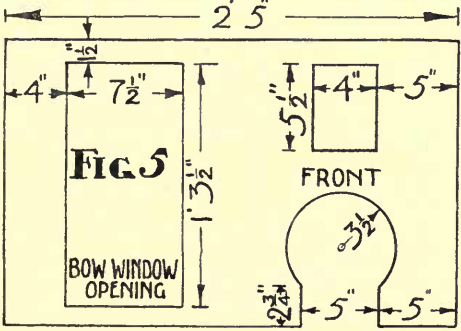
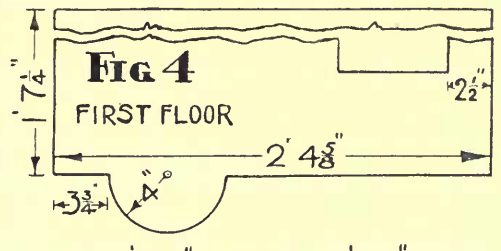
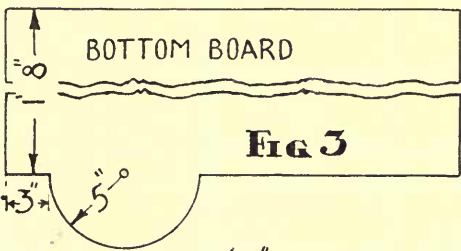
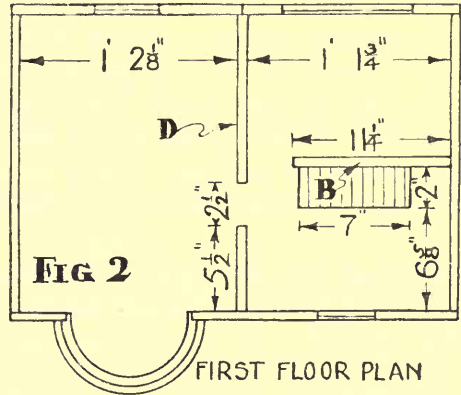
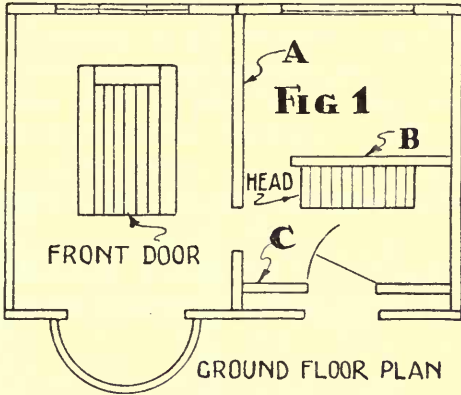
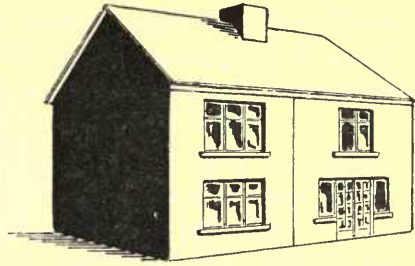
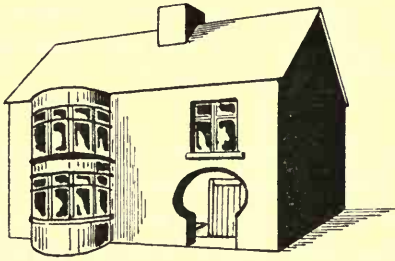

DOLL'S HOUSE—continued

FLAT WINDOWS.—In each window opening, including the French window at the back, fit a piece of $\frac{3}{8}$ " plywood. On this mark out sills, rails and bars (see sketches) and cut them out with a fretsaw. Glue these in position as in Fig. 8.

BOW WINDOW (Fig. 9).—This is built up on semi-circular rings of plywood $\frac{3}{8}$ " thick, faced with stout cardboard. First prepare two straight strips of wood $1' 6" \times \frac{3}{4}" \times \frac{1}{4}"$. From Fig. 9 (section) mark out and cut in each strip the six grooves $\frac{3}{8}$ " wide and $\frac{1}{8}"$ deep and the half-lap joint at each end. Now from $\frac{3}{8}$ " plywood cut six semi-circular rings 5" outside diameter and $\frac{1}{2}"$ wide (see sketch). These are for sills, transoms and top rails. Cut also four semi-circular rings, $4\frac{3}{4}"$ outside diameter and $\frac{1}{4}"$ wide, and two full semi-circles of $4\frac{1}{2}"$ diameter to form top and bottom. Glue the four smaller semi-circular pieces to four of the larger ones—see Fig. 9 (section). To assemble the window glue and pin the strips to the top and bottom pieces, then glue in the four double half rings. Cut strips of cardboard $1\frac{3}{4}"$, $3\frac{3}{4}"$ and $2\frac{7}{8}"$ wide and glue and pin them round the curves (see section). Glue in place the two transom pieces running across each window. Finally cut and glue in place the six vertical pieces, which are of $\frac{1}{4}"$ square section. Glue and screw completed window to front wall (Fig. 5, Page 45).

STAIRCASE (Fig. 10).—Cut two sides or strings, $1' 1" \times 1\frac{1}{4}"$, from $\frac{1}{8}"$ plywood, and twelve blocks $1\frac{3}{4}"$ long of $\frac{3}{4}"$ square section. Glue and pin the blocks between the strings as in Fig. 10.

ROOF.—Cut one piece $2' 6" \times 1' 3\frac{1}{2}"$ and one $2' 6" \times 1' 3\frac{7}{8}"$ with square ends.

CHIMNEY STACK.—Prepare this to dimensions shown in sketch.

FRONT DOOR.—Fit and hinge a piece of $\frac{1}{4}"$ plywood $6" \times 4"$ to partition "C." Cut lines on the face of the door as inset in ground floor plan (Page 45).

ASSEMBLY.—Glue and nail parts together in following order: Ends on bottom, first floor in grooves, partition "A," partition "B," staircase, partition "C," front, the two first floor partitions, then the narrow strip above opening portions of back. Now hinge the two back pieces to the ends and glue and nail on the roof, afterwards gluing and nailing the chimney stack to it. Punch in all nails and the house is ready for painting and equipping.

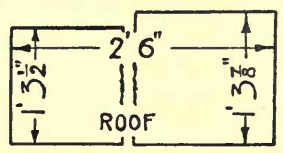
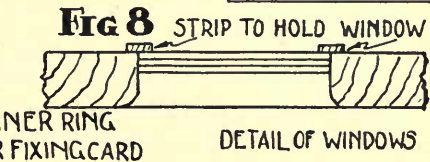
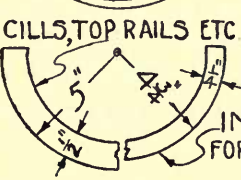
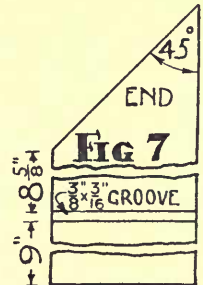
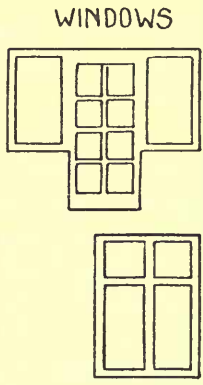
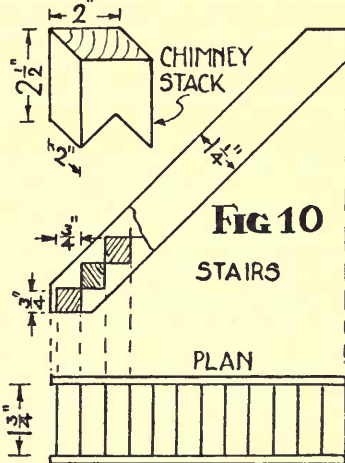
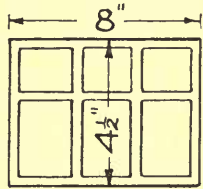
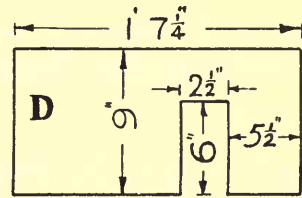
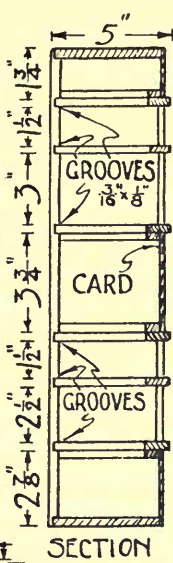
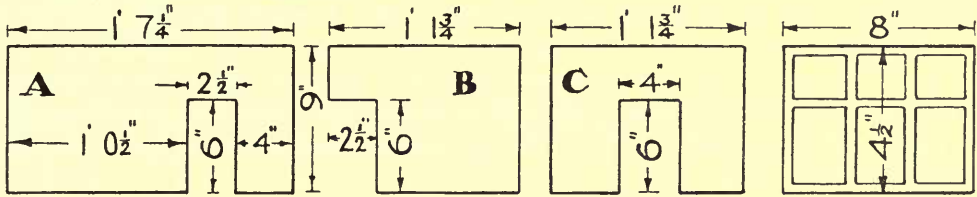
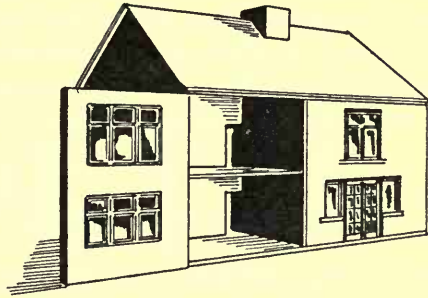

DOLL'S HOUSE: DINING-ROOM SUITE

This and the two pages of drawings which follow deal with furniture for the equipping of the Doll's House. In all the designs the attempt has been made to combine realism, simplicity and strength with a pleasing appearance. The primary aim, however, has been to provide furniture which will make any small girl happy.

CONSTRUCTION

DINING TABLE.—This is 5" long, $2\frac{1}{4}$ " wide and $2\frac{3}{8}$ " high. It should be $\frac{1}{8}$ " thick throughout and may be of either hard or soft wood. Prepare the top $5" \times 2\frac{1}{4}"$ with both ends square, and then the two top bearers $4\frac{1}{4}" \times \frac{5}{16}"$. Bevel the bottom corners as in Fig. 1. Now cut the one stretcher $3\frac{3}{4}" \times \frac{1}{2}"$. For the legs prepare four pieces $2\frac{1}{4}" \times \frac{1}{2}"$. At one end of each cut a slot $\frac{5}{16}" \times \frac{1}{8}"$ (Fig. 2). Each foot is built up of four pieces, two $2" \times \frac{1}{4}"$ and two $\frac{1}{4}" \times \frac{1}{4}"$. Glue up the foot and, when set, bevel the corners as in Fig. 2. Clean up all parts.

ASSEMBLY.—Glue and pin top bearers to legs, then legs to feet. Glue and pin top to bearers and finally stretcher to feet. Great care must be taken to keep all parts "square."

DINING CHAIR (Fig. 3, A, B, C, D).—Prepare a block (A) $2\frac{3}{4}" \times 1\frac{1}{2}" \times 1\frac{1}{2}"$ with both ends square. Mark out and cut away seat portion (B). With a bow saw carefully cut away waste between legs (C). Pare underside of seat flat with sharp chisel, then glue and pin plywood (D) in place to strengthen short grain of seat. Round-off the seat, back and the front legs, and cover with thin leather as sketch at head of page.

SIDEBOARD.—This is 4" long, $2\frac{1}{2}"$ high and $1\frac{1}{2}"$ deep. It is made of $\frac{1}{8}"$ thick material throughout. Prepare top and bottom $3\frac{7}{8}" \times 1\frac{1}{2}"$, and two sides $2\frac{1}{4}" \times 1\frac{1}{2}"$, then cut the joints as in Fig. 4. Cut two doors $2" \times 1\frac{3}{8}"$, and round-off one long edge of each. Insert two pivots in each (Fig. 6). Panel or veneer pins may be used for these. The centre panel is $2" \times 1"$ with three horizontal V cuts to represent drawers (Fig. 5). Add the door and drawer handles, which are from $\frac{1}{8}" \times \frac{1}{8}"$ section material and glued on. Two suggestions for handles are shown, one in Fig. 4 and one in sketch at top of page. Drill holes in top and bottom for the pivots. Clean up all parts.

ASSEMBLY.—Glue and pin sides to bottom. Place doors and centre panel in position, then glue and pin sides to top and top to centre panel. Cut, fit and fix a piece $3\frac{3}{4}" \times 2"$ into the back. Glue two pieces $1\frac{3}{8}" \times \frac{1}{4}" \times \frac{1}{4}"$ to bottom for feet. Glue a small strip along joint where centre panel meets bottom, and allow to project slightly as a door stop.

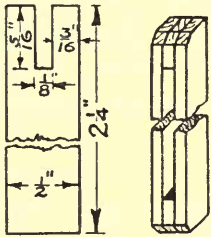
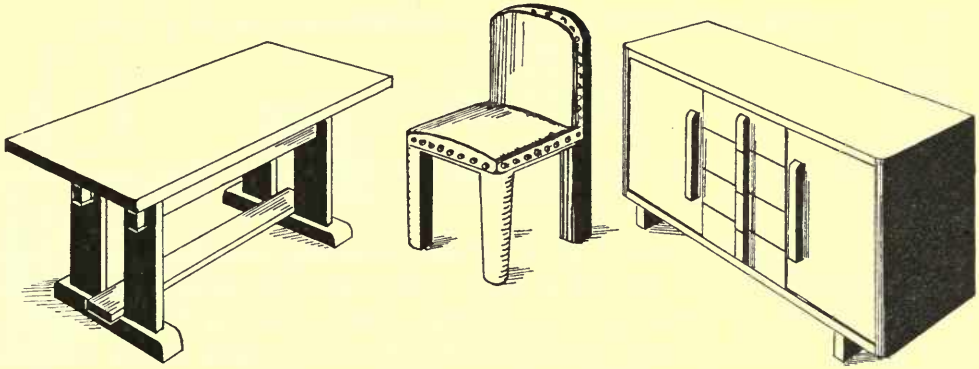

FIG 2

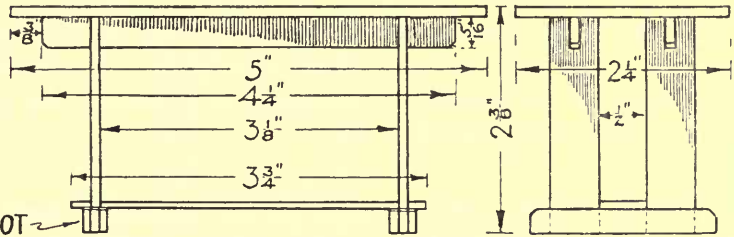

FIG 1

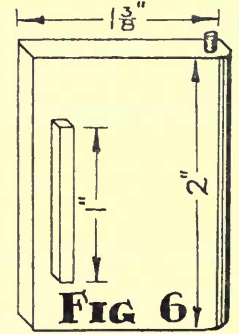
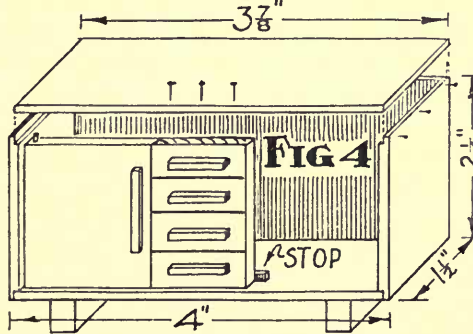
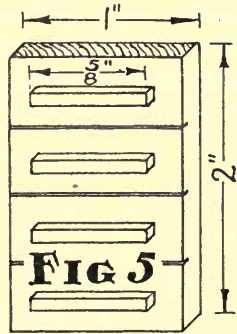
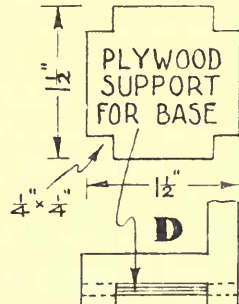
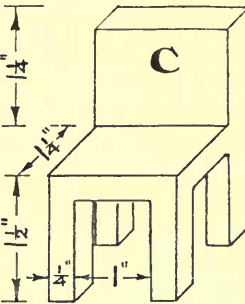
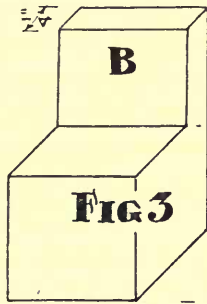
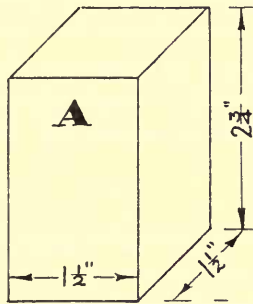

FIG 6

DOLL'S HOUSE: BEDROOM SUITE

All the material used in this suite, as in the previous one, is $\frac{1}{8}$ " thick.

CONSTRUCTION

WARDROBE (Fig. 1).—This stands $5\frac{3}{4}$ " high, is 4" wide and $1\frac{1}{2}$ " deep, and is mounted on four feet $\frac{7}{8}$ " \times $\frac{1}{4}$ " \times $\frac{1}{4}$ ".

Prepare two sides, or "cheeks," $5\frac{1}{2}$ " \times $1\frac{1}{2}$ " and cut halving joints on the ends. Prepare also two pieces $3\frac{7}{8}$ " \times $1\frac{1}{2}$ " for top and bottom. Clean up inside faces, then glue and pin parts together, carefully checking for squareness. Make level the front and back and glue and pin on to the back a piece $5\frac{1}{2}$ " \times 4". Two side panels should now be cut $5\frac{1}{2}$ " \times $1\frac{1}{4}$ " and glued and pinned to the front as in sketch. Prepare a door which is $5\frac{1}{2}$ " \times $1\frac{1}{2}$ " and fit this between the side panels. Hang the door by a pair of small "butt" hinges on its right edge. Glue in place a strip of $\frac{1}{8}$ " \times $\frac{1}{8}$ " section as a handle. Round-off the top edges of the wardrobe, then clean up all round, and glue and pin in place the four feet shown in the inset, Fig. 1.

DRESSING TABLE.—This is kidney-shaped, 4" long, 2" deep, and $2\frac{1}{2}$ " high. From a piece 4" \times 2" mark out and cut the top. Make notches for the mirror supports. The two uprights are $2\frac{3}{8}$ " \times $1\frac{1}{4}$ ". Cut two grooves $\frac{1}{8}$ " wide and $\frac{1}{16}$ " deep for the shelf, which is $2\frac{1}{4}$ " \times $1\frac{1}{4}$ ". Clean up these parts, then glue and pin them together, checking carefully for squareness. For the mirror cut a piece $2\frac{1}{8}$ " \times $1\frac{1}{2}$ ". This piece should be covered with a smooth piece of tin foil. Two supports $2\frac{1}{2}$ " \times $\frac{1}{4}$ " should now be shaped as shown and a small hole drilled in each to take the pivots of the mirror, for which two small panel pins may be used. Glue supports in position with mirror mounted and finally fold a piece of suitable material round front of table.

BED.—The bed is $5\frac{3}{4}$ " long and 4" wide. From a piece $2\frac{1}{2}$ " long (measured **along** the grain) and 4" wide mark out the headboard. Cut a groove for the bottom $\frac{1}{8}$ " wide and $\frac{1}{16}$ " deep, then cut and finish the curve. Repeat for the footboard, which is $1\frac{5}{8}$ " long and 4" wide. Cut the bottom $5\frac{1}{2}$ " \times 4" with both ends square. Prepare two side bearers $3\frac{3}{4}$ " \times $\frac{3}{8}$ ". Clean up all parts, glue and pin headboard and footboard to bottom, then glue and pin bearers to bottom, headboard and footboard. Shape four feet similar to those of wardrobe and glue and pin in position as in sketch.

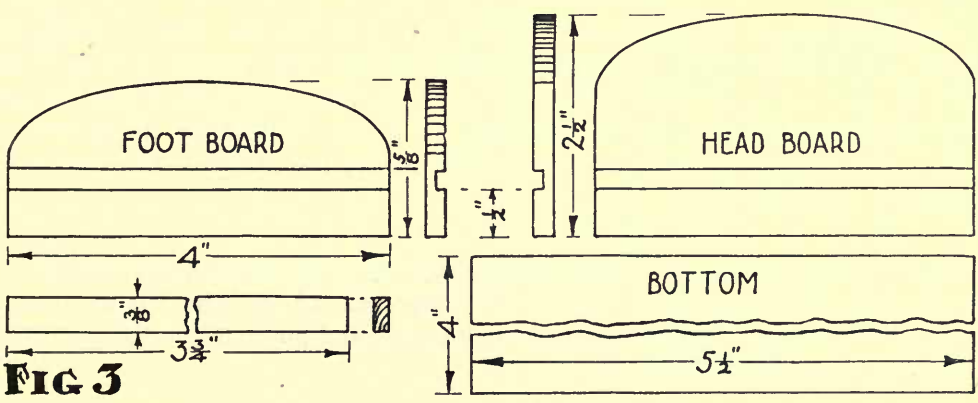
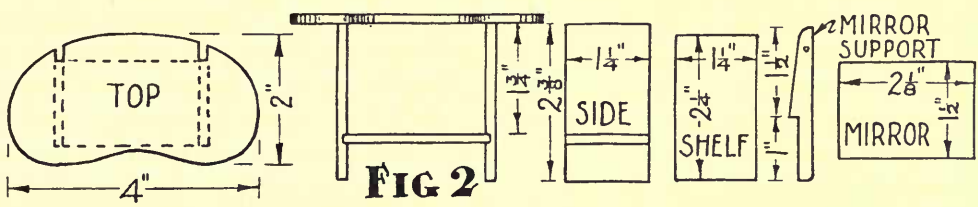
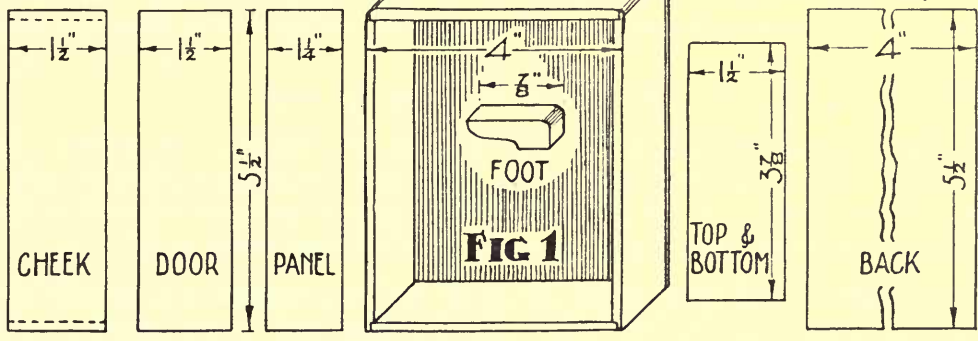
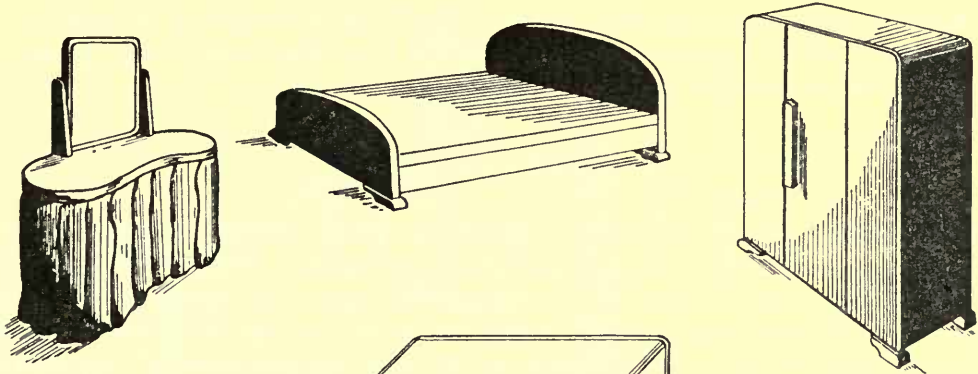

DOLL'S HOUSE: KITCHEN FURNITURE

Apart from the legs of the table this furniture is made throughout of material $\frac{1}{8}$ " thick. When finished it should be painted in suitable colours, e.g., green and white, or blue and white.

CONSTRUCTION

CHAIRS (Fig. 1).—Legs, backs and arms of these are of $\frac{1}{8}$ " cane. Cut bottoms from $\frac{1}{8}$ " plywood to dimensions shown. Drill $\frac{1}{8}$ " holes for legs and enlarge those of the arm chair to take two pieces of cane. The arms and front legs of this chair are in one piece. In both chairs the back legs and back arms are in one piece, the legs being bent back after insertion through the seat. The front legs are $1\frac{5}{8}$ " long, legs plus arms $3\frac{1}{4}$ ", and back legs and back 4". Cut cane to length and glue in position, taking care to keep legs level.

DRESSER (Fig. 2).—This is 5" wide, 6" high, and $1\frac{1}{2}$ " deep.

Top Section.—Cut four pieces $4\frac{3}{8}" \times \frac{5}{8}" \times \frac{1}{8}"$ for top, bottom and shelves. Make two sides $3\frac{1}{2}" \times \frac{5}{8}"$ as illustrated with halving joints at the ends and grooves $\frac{1}{8}"$ wide and $\frac{1}{16}"$ deep, for the shelves. Clean up the inside faces, glue and pin parts together, checking carefully for squareness, then fasten on the $\frac{1}{8}"$ plywood back which is $4\frac{1}{2}" \times 3\frac{1}{2}"$.

Bottom Section.—Cut three pieces $4\frac{7}{8}" \times 1\frac{3}{8}"$ for top, bottom and division piece, and also two pieces $2\frac{1}{2}" \times 1\frac{3}{8}"$ for sides. Cut a halving joint at the top end and two grooves $\frac{1}{8}"$ wide and $\frac{1}{16}"$ deep for the division and the bottom. The two doors $1\frac{1}{2}"$ high and $2\frac{3}{8}"$ wide are pivoted as in the sideboard (Page 49). **Note that these doors and the "drawer" fronts are set back $\frac{1}{8}"$ from the front face of the dresser.** The "drawer" fronts are in one piece $4\frac{3}{4}" \times \frac{1}{2}"$. Now make a vertical division piece $1\frac{1}{2}" \times \frac{3}{8}"$ and a plinth piece $4\frac{3}{4}" \times \frac{1}{8}"$. Bore holes for the door pivots, clean up all parts, and fasten on the handles, which are $\frac{1}{8}"$ square section, 1" long for doors and $1\frac{1}{4}"$ for drawers.

To Assemble.—Begin by gluing and pinning the sides to the bottom, then insert the doors and fix the horizontal division. Glue and pin the vertical division in place followed by the "drawer" front. Now glue and pin down the top and glue the plinth in place. Complete this section by fastening on the back, which is $\frac{1}{8}"$ plywood and $5" \times 2\frac{1}{2}"$. Finally clean up both sections, round-off the top corners, and glue and pin both sections together.

TABLE (Fig. 3).—Cut top $5" \times 3\frac{1}{2}"$, two side rails $4\frac{3}{4}" \times \frac{3}{8}"$, and two end rails $2\frac{3}{4}" \times \frac{3}{8}"$. Shape four legs $2\frac{3}{8}"$ long and $\frac{1}{4}" \times \frac{1}{4}"$ at the top tapering, **on the insides only**, to $\frac{3}{16}" \times \frac{3}{16}"$ at the bottom. Clean up all parts, then glue and pin end rails to legs, followed by side rails. Lastly glue down top.

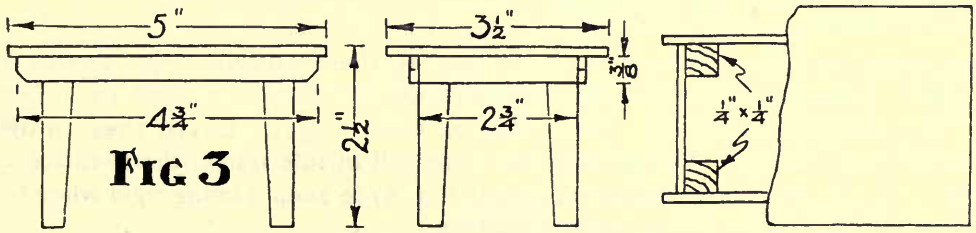
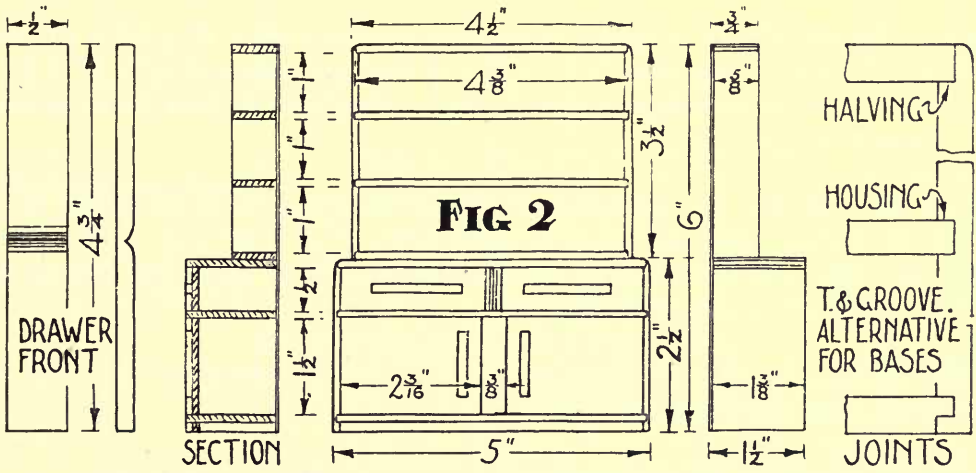
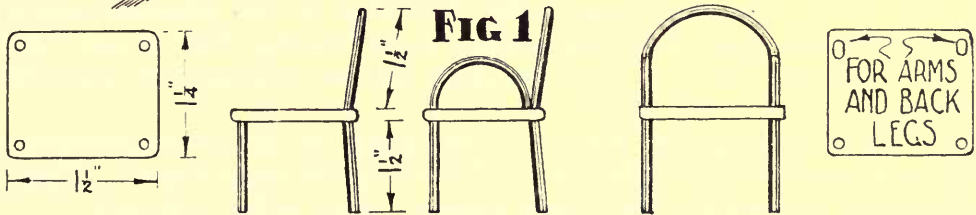
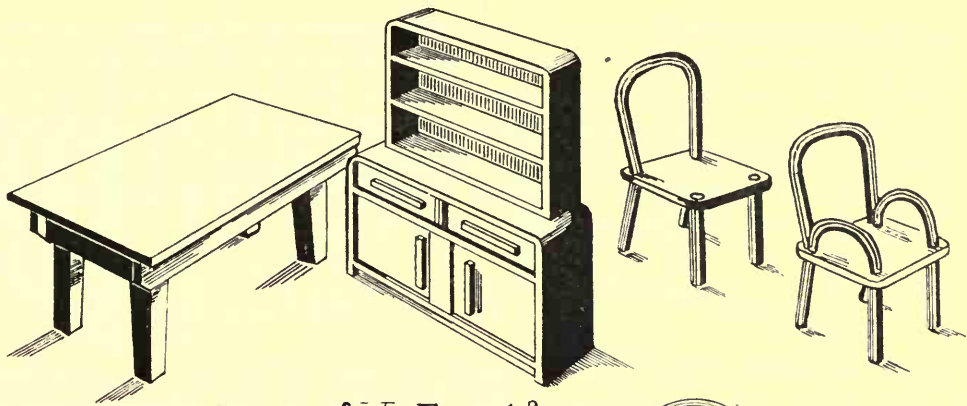

MARIONETTE THEATRE

This marionette theatre is built up of six pieces of framing—front wall with proscenium opening, back frame supporting the bridge, and four side frames which fold inwards so that the entire theatre can easily be transported or packed in a very small space. There is ample room for lights and scenery and for hanging puppets in convenient places. The front framing may be covered with plywood or stout card and painted, it may be panelled, or it may be covered with pleated linen, hessian or crash.

CONSTRUCTION

FRONT FRAMING (Fig. 3).—First decide on joint to be used (i.e., whether as at "A" or "B"). For the purpose of this description we will assume a half-lap joint as at "B" is to be used. From deal prepare to the following finished sizes: One top and one middle rail $5' 0" \times 2" \times \frac{3}{4}"$, two stiles and two muntins $3' 6" \times 2" \times \frac{3}{4}"$, and two bottom rails $1' 3" \times 2" \times \frac{3}{4}"$.

Mark out joints, as at "B" and "C." The middle rail is in one piece with a lapped halving joint where it crosses the muntin. Cut out and fit joints "dry." Clean inside edges and glue up, keeping frame square and flat. Leave to set.

BACK FRAME (Fig. 7).—Prepare to finished sizes—top rail $5' 0" \times 3" \times \frac{3}{4}"$; bottom rail $5' 0" \times 2" \times \frac{3}{4}"$; two stiles $2' 3" \times 2" \times \frac{3}{4}"$ and one muntin $2' 0" \times 2" \times \frac{3}{4}"$. Set out, cut, fit, clean inner faces and glue up, again taking care to keep frame square and flat. Put aside to set.

SIDE FRAMES (Fig. 4).—An enlarged view of one frame is shown in Fig. 5. Four are to be made. Cut and prepare eight stiles $2' 3" \times 1\frac{1}{2}" \times \frac{3}{4}"$ and eight rails $11\frac{1}{4}" \times 1\frac{1}{2}" \times \frac{3}{4}"$. Mark out halving joints as before, cut, fit, clean and glue up square and flat. Allow glue to set, then clean off.

BRIDGE (Fig. 8).—Cut and finish this $5' 0" \times 4" \times \frac{3}{4}"$. Bore five $\frac{3}{16}"$ screw holes, countersink, then round the top edges.

ASSEMBLY.—When glue of frames is hard, clean off sides and outer faces.

Procure six pairs of $1\frac{1}{2}"$ or $2"$ "butt" hinges.

Fit hinges on centre joint of ends first (Fig. 4), then **remove** hinges as side frames are easier to handle one at a time. Screw hinges on face of internal angle between front and side frames (Fig. 6). Test swing on these hinges. **Leave these hinges in place.** Repeat at angle of back frame and rear half of side frame, then replace centre hinges. Fix pair of cabin hooks across corner (Fig. 6) to keep framing rigid when theatre is in use. Finally screw bridge piece in position.

CURTAINS.—For these see Page 124.

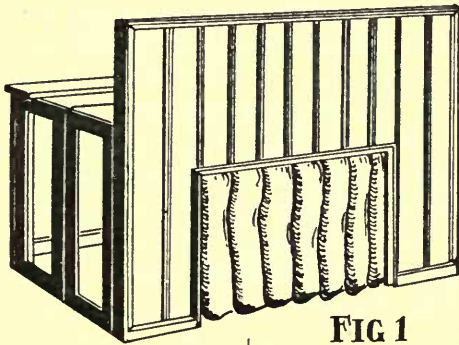

FIG 1

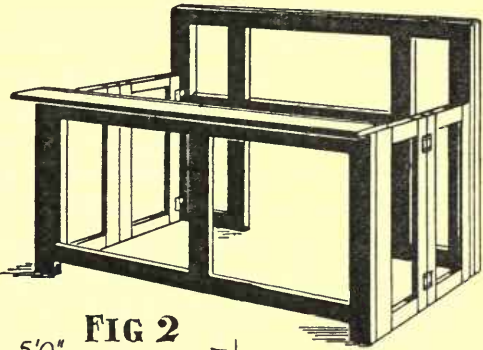

FIG 2

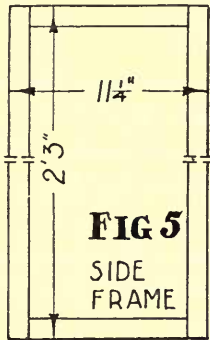

FIG 5
SIDE
FRAME

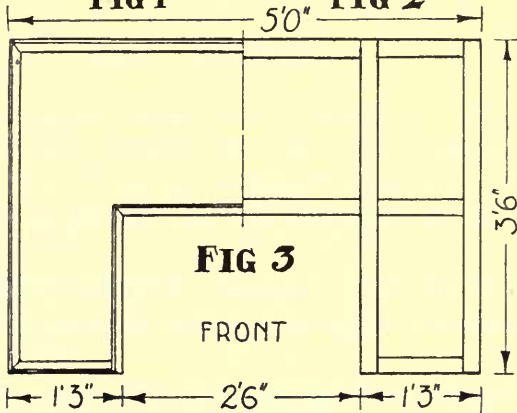

FIG 3
FRONT

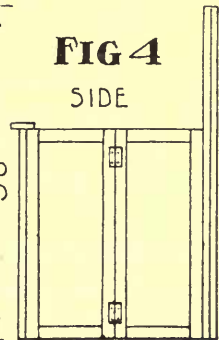
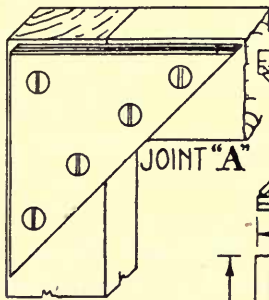

FIG 4
SIDE



JOINT "A"

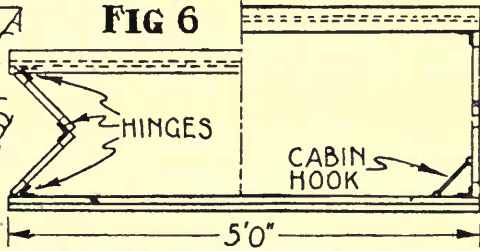
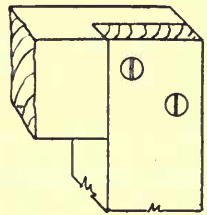

FIG 6

HINGES

CABIN
HOOK

5'0"



JOINT "B"

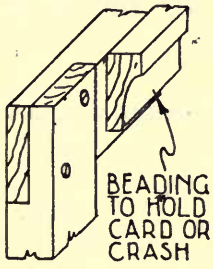

BEADING
TO HOLD
CARD OR
CRASH

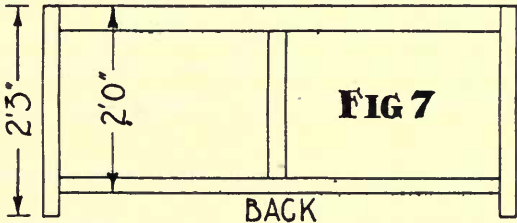

FIG 7

BACK

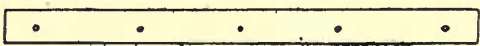
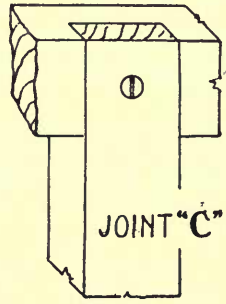

FIG 8



JOINT "C"

GLOVE - PUPPET THEATRE

This puppet theatre is both a piece of valuable educational apparatus and also a great source of interest and amusement to children. It consists of front and side framing, two wings, a stage and a spacing bar. To the front framing (Fig. 1) are hinged the two side frames (Fig. 2) which may be folded inwards (Fig. 4) when the theatre is not in use. The stage (Fig. 3) is a loose board notched to drop on the middle rail. Around its front edge is tacked a pleated linen, hessian or crash curtain, which is repeated on the top rail. One of the two wings is shown in Fig. 5. The spacing bar (Figs. 4 and 6) rests on the side frames and has two metal clips (Fig. 7(a)) to hold the frames open. Two brackets (Fig. 7(b)) are attached to the side frames to hold back-drops, etc.

CONSTRUCTION

FRONT FRAMING (Fig. 1).—Decide which joints shall be used (see Page 55), then cut and prepare two stiles $2' 6" \times 3\frac{1}{2}" \times \frac{3}{4}"$, bottom and top rails $3' 0" \times 3" \times \frac{3}{4}"$, middle rail $3' 0" \times 1\frac{3}{4}" \times \frac{3}{4}"$, and a muntin $1' 1\frac{1}{2}" \times 1\frac{3}{4}" \times \frac{3}{4}"$. Fit the joints "dry," number them, then clean the edges and glue up, keeping frame square and flat.

SIDE FRAMES (Fig. 2).—Two are required. Construction is similar to that of front framing. To each glue and pin, or screw, a piece of plywood or stout card $2' 4" \times 1' 6"$.

STAGE (Fig. 3).—Prepare from deal board $2' 10" \times 4\frac{1}{2}" \times \frac{5}{8}"$.

WINGS (Fig. 5).—Cut from stout plywood. Along one edge glue and pin a deal strip $1' 2\frac{1}{2}" \times 1\frac{1}{2}" \times \frac{1}{2}"$. Into this screw two small hooks (Fig. 5).

SPACING BAR (Fig. 6).—This is a piece of batten $3' 1\frac{1}{2}" \times 1\frac{1}{2}" \times \frac{5}{8}"$. Fix two metal clips (Fig. 7(a)) in position to hold the wings open.

ASSEMBLY.—Clean up front and side frames. Fasten each side frame to the front with two 2" "butt" hinges. Fix two small screw eyes $\frac{3}{4}"$ within either side of the proscenium opening to take the hooks of the wings (Fig. 4) and two brackets (Fig. 7(b)) on top of back edges of side frames to support back-drops—see Fig. 2.

FINISH by painting woodwork which is seen, and fixing pleated material across top and across front of stage.

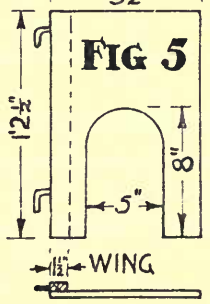
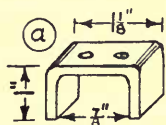
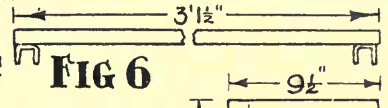
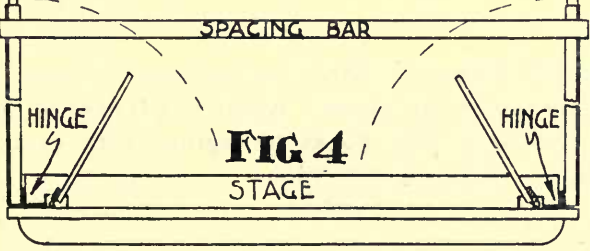
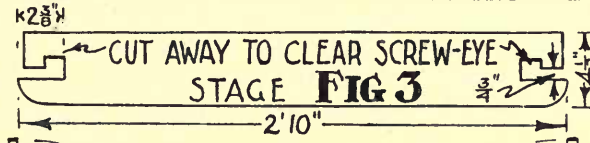
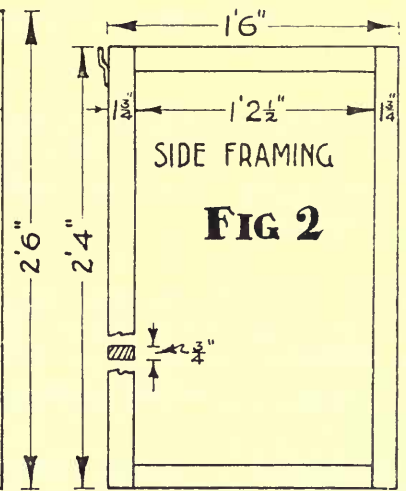
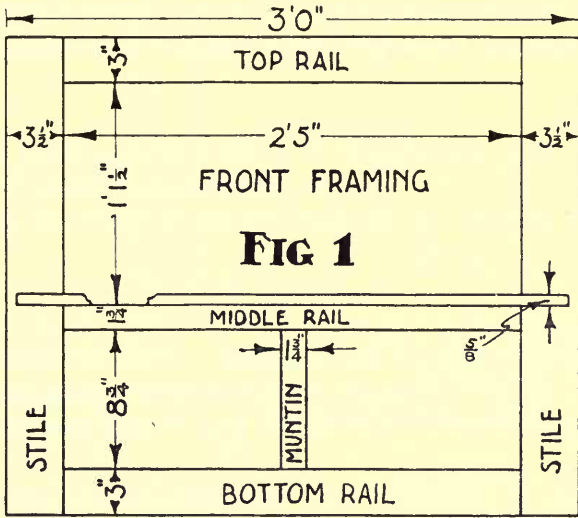
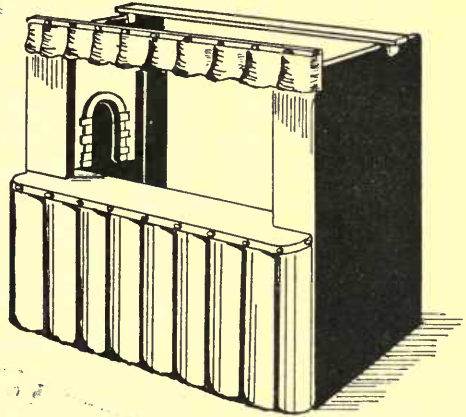
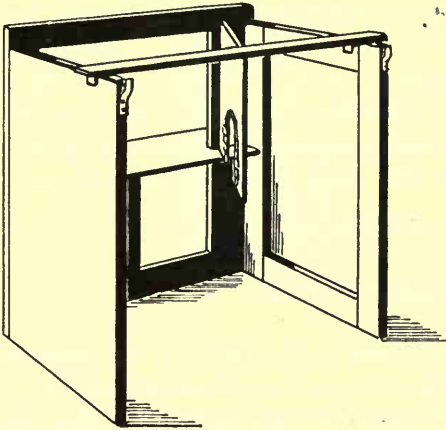

MODEL THEATRE

This theatre is not merely a toy ; it is a useful basic model both for the designer of stage settings and the model theatre enthusiast. Constructed of deal and made to fold up, the theatre is 3' 6" wide, 2' 4" high, and 1' 6 $\frac{3}{4}$ " deep. Both side frames (Fig. 2) are hinged to the front framing (Figs. 1 and 3), and the box tiers (Fig. 4) swing on hooks and eyes and fold inwards (Fig. 3) when the theatre is not in use. The stage (Fig. 5) is loose and has grooves along which slide the figures.

CONSTRUCTION

FRONT FRAMING (Fig. 1).—Prepare four pieces 2' 4" \times 1 $\frac{3}{4}$ " \times $\frac{3}{4}$ " for stiles and muntins, two pieces 3' 6" \times 1 $\frac{3}{4}$ " \times $\frac{3}{4}$ " for top and middle rails, and two bottom rails 8 $\frac{1}{4}$ " \times 1 $\frac{3}{4}$ " \times $\frac{3}{4}$ ". From the elevation (Fig. 1) and from Fig. 6 mark out halving joints. Cut the joints, fit together "dry," and number. Take the framing apart, bore and countersink screwholes and clean all inside edges. Glue up framing, keeping it flat and square and put aside to "set."

SIDE FRAMING (Fig. 2).—Prepare two long stiles 2' 0" \times 1 $\frac{3}{4}$ " \times $\frac{3}{4}$ ", two short stiles 1' 9" \times 1 $\frac{3}{4}$ " \times $\frac{3}{4}$ ", and four rails 1' 6" \times 1 $\frac{3}{4}$ " \times $\frac{3}{4}$ ". Further constructional details are as for front framing. The short lengths of dowel on top edge are for hanging back-drops, etc., if desired.

BOX TIERS (Fig. 4).—Cut two pieces of $\frac{3}{16}$ " plywood 2' 4" \times 1' 0". From Fig. 4 mark out box openings and cut out with fret or key-hole saw. Clean up openings. Glue and pin a stiffening piece 2' 4" \times 1 $\frac{1}{4}$ " \times $\frac{5}{8}$ " along one long edge of each piece (Fig. 4). The "Boxes" are formed by gluing a cardboard box over the back of each opening.

STAGE (Figs. 3, 5 and 8).—This is 3' 6" \times 1' 6 $\frac{3}{4}$ " \times $\frac{3}{4}$ ". A number of pieces of board may be cut and jointed to this size or, for a lighter stage, a frame may be made and covered with a sheet of plywood or strong card. Above this glue and pin twelve slats 3' 6" \times 1" \times $\frac{1}{2}$ " (Figs. 5 and 8), completing the stage with one wide slat in front. Cut away corners as in Fig. 5. Suggestions for sliding the figures, etc., along the grooves thus formed are illustrated in Fig. 7.

ASSEMBLY.—Clean up front and side framings. Screw in four eyes for box tiers. Bore and glue short lengths of dowels in top of side frames. Attach side frames by hinges—see Fig. 3. Clean up box tiers. Screw in four hooks to register with eyes. Fit framing to stage. Paint and decorate.

SCENERY FOR MODEL THEATRE

No dimensions are given in these drawings, which are intended to be suggestive of types of scenery, etc., suitable for use with the model theatre or with the puppet and marionette theatres on Pages 54 and 56.

CONSTRUCTION

DOORWAYS (Figs. 1 and 2).—The doorway in Fig. 1 is to be made of cardboard. Paint the door on the face side as suggested and cut along one side and across the top. Fold along broken line. A paper clip may be used as a fastener. A plywood door is illustrated in Fig. 2. Here the door is cut out completely and hung on very small metal, leather or linen hinges. Paint front as shown.

WINDOWS (Figs. 3 and 4).—Mark out front and cut three sides of frame as in Fig. 3. Fold back to form hinge. Cut out spaces between bars as different lighting effects can be obtained by pasting thin coloured paper on backs of windows. A window in which the bottom sash slides up is illustrated in Fig. 4. This may be of plywood or card. First cut out window opening represented by broken line. Over this opening at the back glue a piece similar to the shaded portion (Fig. 4). This forms the upper sash, and the projecting portions down each side guide and hold in place the lower sash. Cut a frame and sill piece, fitting in similar manner over the front of the opening. Cut out and insert the lower sash, then glue the front fitting in place. The glued-on front and back portions then form guides between which the lower sash may be raised or lowered.

FIREPLACES (Figs. 5 and 6).—The first of these may be in card. Paint the fireplace on the face. Cut an opening at back of grate and paste red or yellow paper over it. A small light behind gives the effect of a fire. In Fig. 6 is shown a fireplace in which small blocks of wood are glued to the front forming pilasters, mantelshelf and grate. Coloured paper again will suggest fire.

STAIRS (Fig. 7).—The setting out, in one piece of card, of treads and risers is shown in Fig. 7. The card is to be folded along the broken lines. In the other sketch is a suggestion for handrail, etc., and spandrel against which are glued the treads and risers.

BALUSTRADING (Fig. 8).—This is cut out from a piece of stout card or plywood which is glued to a baseblock for support.

TREE (Fig. 9).—This, or any similar property, may be made and supported in like manner to the balustrading.

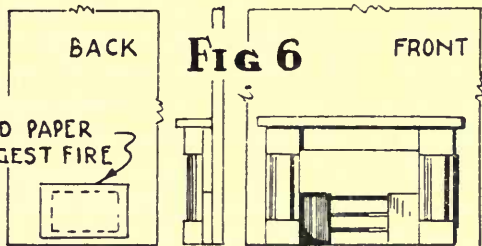
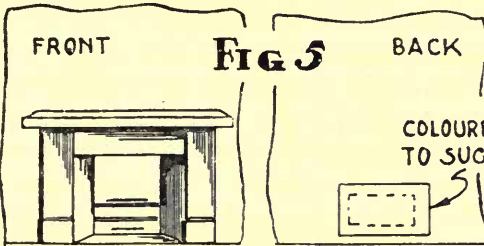
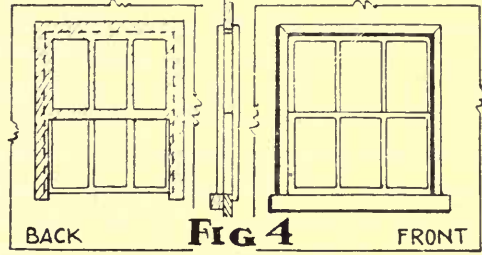
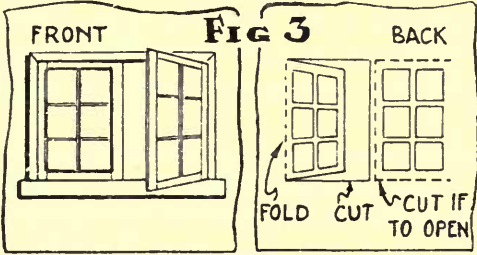
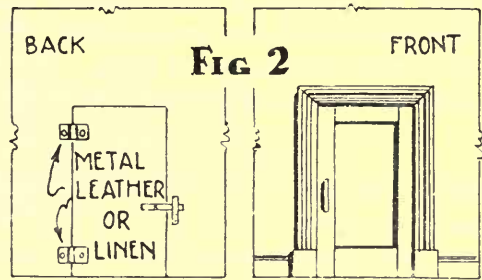
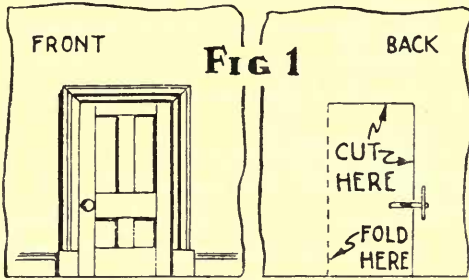

STAIRS

FIG 7

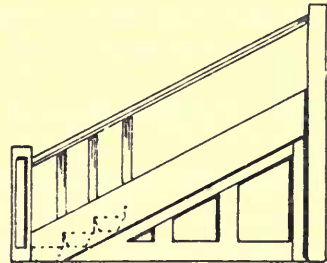

BALUSTRADING

FIG 8

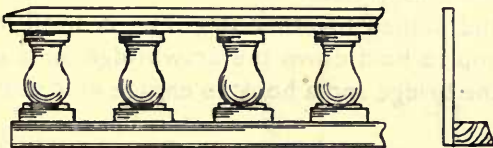

TREES

FIG 9

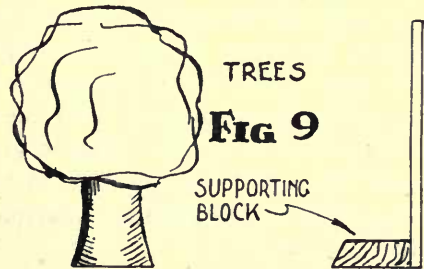

C A S T L E

Even in this age of mechanization castles appeal very strongly to children. This castle has a drawbridge which rises by means of weights and is held down by a small button on the ramp. The keep, walls and towers are all separate units and may be stored away inside the base when the castle is not being used.

CONSTRUCTION

BASE.—This is 2' 0" × 1' 2" and is 4½" deep. Prepare two side pieces 2' 0" × 4" × ½", and two end pieces, one 1' 2" × 4" × ½" and the other 1' 2" × 3½" × ½". Along the three 4" wide pieces plough a ¼" × ¼" groove, ¼" from the face edges. Fix the base together by means of dovetail joints (Fig. 1). The bottom consists of two thicknesses of ¼" plywood. Glue and pin one piece to the sides and ends. From Fig. 5 mark out and pierce the second piece. This piece forms grooves and recesses to hold the walls and towers in place. Glue and pin it in position on the first piece. Finally cut and fit a piece of ¼" plywood for a sliding top.

SQUARE TOWERS.—From ⅜" plywood make four closed "boxes" 4" × 2" × 2" with butt joints. Before gluing the "boxes" together cut a mortice 1½" × ¼" through each of two adjacent sides (Fig. 4). The battlements are first cut out in a piece of ¼" plywood, 1¼" wide, then butt-jointed round the top of the tower (Figs. 2 and 4). The two square towers at the back of the keep are 8½" × 2" × 2".

ROUND TOWERS.—These are made by rolling pieces of thin card, 8½" wide for the keep and 5" wide for the entrance, round a wooden cylinder 1¾" diameter. The card is glued as it is rolled (Fig. 4). When the cylinders are dry cut two plywood discs for each tower 1¾" diameter. Glue one in the bottom end and the other 1½" from the top end (see section, Fig. 6). As in the square towers cut mortices for wall tenons (Fig. 4). The battlements are cylinders of card, each 1¼" long, large enough to fit over the end of a tower and notched like those of the square towers.

WALLS.—The walls are rectangular pieces, ⅝" thick with a short tenon of ¼" plywood let into the ends (Figs. 2 and 3). The battlements are similar to those of the square towers.

KEEP.—Complete this with the roof (Fig. 7) and entrance steps (see section and plan, Fig. 1).

ENTRANCE.—From a piece of deal 8½" × 4" × ⅝" cut out the given shape (Fig. 6). The towers are fixed to the gateway by two 1½" × ⅝" tenons (see section, Fig. 6). Two strings or thin chains are fastened to the drawbridge which is 4" × 3½" × ⅜". The chains should be fastened 3" from the back edge of the bridge. The method of hinging the bridge by means of two thin plates ¼" wide is shown in Fig. 7. The lifting chains pass through holes in the gateway and have two small lead weights attached to their ends. Adjust these weights until the bridge slowly rises.

RAMP.—This is of thin plywood glued and pinned together (Fig. 7). A small metal or wood "button" may be fixed to the ramp to hold down the drawbridge, or a small screw-eye may be fixed in the underside of the bridge and a hook to engage in it screwed to the side of the ramp.

FINISH the castle by painting to imitate stone. Paint in doors and windows to keep and loopholes in walls.

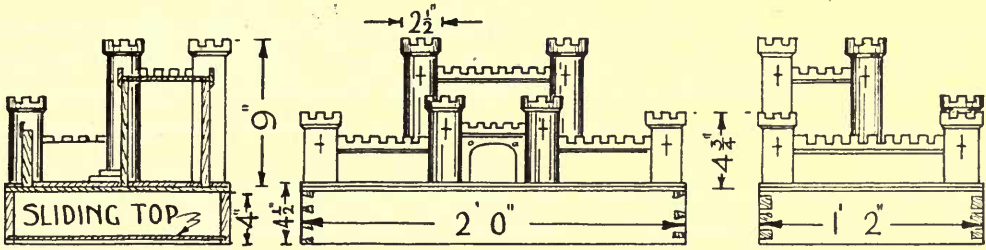
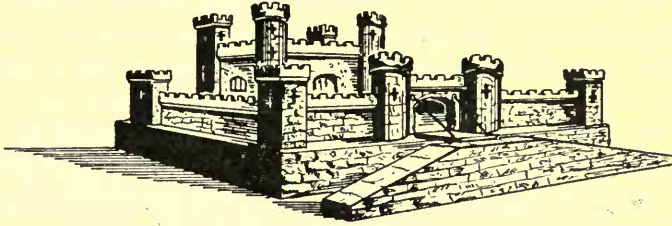

SECTION

Fig 1

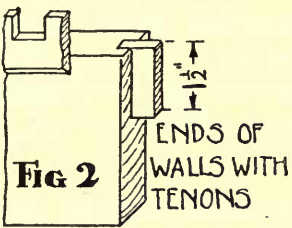
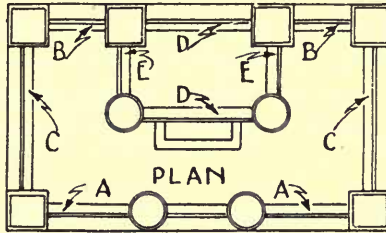

Fig 2



PLAN

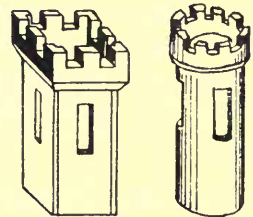
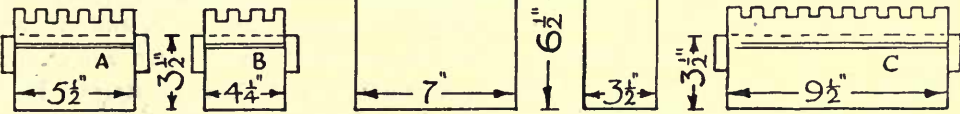

Fig 4 TOWER WITH MORTICES FOR WALL TENONS

Fig 3 WALL PIECES TWO OF EACH REQUIRED



HALF PLAN OF PIERCED BOTTOM

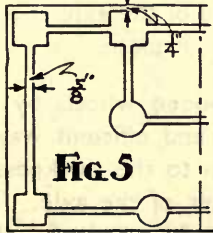

Fig 5

Fig 6 SHOWING ENTRANCE SHOWING METHOD OF FIXING TOWER TO GATEWAY BY TENON

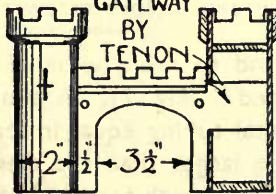
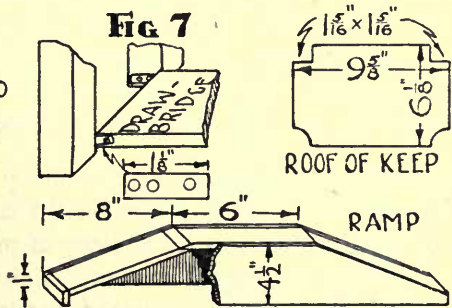

Fig 7



WHEELS: THEIR MAKING AND FIXING

One of the chief problems of the toy-maker is the making of wheels. They may, of course, be bought, but generally the man who delights in making the body of the toy gets an equal satisfaction from fashioning the wheels.

Only if made from hardwood, such as ash, beech, birch and hornbeam, free from shakes or other defects, can wooden wheels be expected to last well ; they should also be well proportioned in relation to the rest of the toy, and large enough to travel easily and quickly. Sufficient thickness to enable them to withstand shocks and hard wear is an additional requisite.

Wheels for small toys not expected to receive very rough usage are sometimes cut from old curtain poles or thick dowel rod. If the wheels are cut thick and the pole is old, and so well seasoned, the wheels are often quite satisfactory. Large wheels should not be made this way, as the grain of the wood runs in the wrong direction to withstand side strain.

The ends of old dumb-bells make very useful wheels if kept thick. They are quite suitable for use in such toys as the Warehouse Trolley on Page 110.

WHEEL FIXING

BY SCREWS.—Rarely is screwing a satisfactory form of fastening wheels. If screws **must** be used, the toy should be so designed that the screws are driven into the side of a piece of hardwood, and as sturdy a screw as the construction will allow should be used (Fig. 1). Every effort should be made to avoid screwing wheels into end grain (Fig. 2).

ON AXLES.—Where a toy must withstand robust handling, wheels should be fixed to a mild-steel axle. This, in turn, should be passed through a bearer, or other part of the body (Fig. 3), which will hold it firmly and absorb any shock ; the practice of boring holes through an axle and screwing it to the body (Fig. 4) should be avoided. The holes weaken the axle and the screws soon work loose or break. When it is desirable to plant an axle on a base the axle should be held by a capping piece glued and screwed to the base, as in Fig. 5. A washer should be placed on both sides of each wheel and the wheels held on the axle by a split pin passing through a hole bored in it (Fig. 3). The washers help to eliminate friction between the wheel and the surrounding parts, and prevent wear of the wheel by the split pin. The projecting end of the axle should be kept short. If there is any fear of its causing injury to a child it may be covered by a small "press in" tin lid screwed to the wheel and covering the end of the axle and the split pin (Fig. 6). Fill the lid with thick grease before screwing it in place.

BUSHING.—To ensure easy running and to avoid wear of wooden wheels by the metal axles, the wheels should be "bushed" (Fig. 7). A simple and efficient way of making a bush is to saw off a piece of metal tubing equal in length to the thickness of the wheel and in internal diameter a little larger than the diameter of the axle. The hole in the wheel should be bored just large enough for the bush to be a tight fit when lightly tapped in.

(Continued on Page 66)

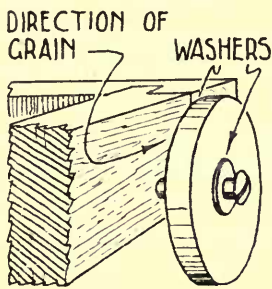
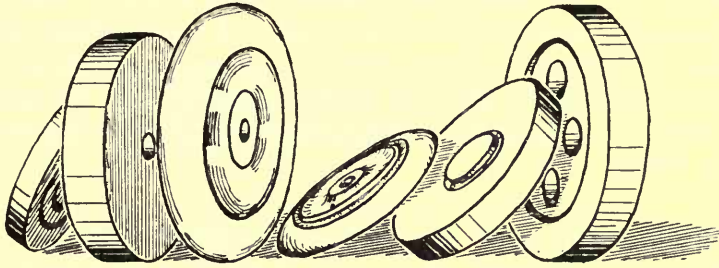

FIG 1

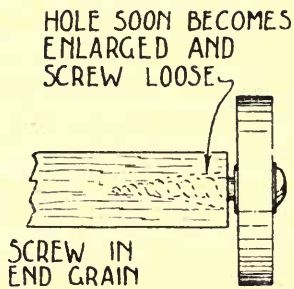

FIG 2 WRONG METHOD

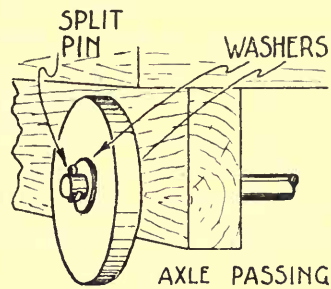

FIG 3 THROUGH BEARER

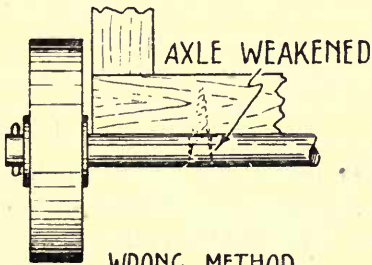

FIG 4 WRONG METHOD SCREW THROUGH AXLE

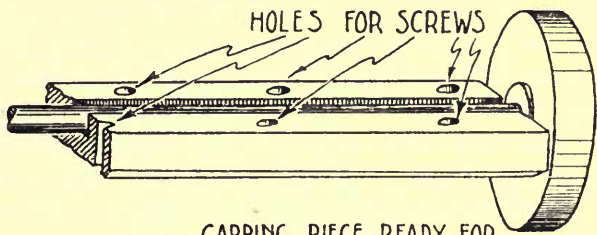

FIG 5 CAPPING PIECE READY FOR GLUING AND SCREWING TO BASE

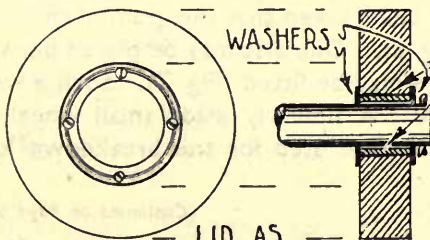

FIG 6 LID AS GUARD OVER AXLE

LID READY TO BE SCREWED TO WHEEL

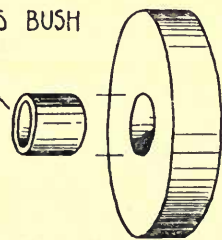

FIG 7 BUSHING

THE SHAPING OF WHEELS

Wheels can be shaped by the simple use of bow saw, chisel or spokeshave, and finished by means of file and glasspaper. Unfortunately this is a slow and laborious method which frequently results in wheels which are not truly circular, and often are of unequal diameters. There are, however, several satisfactory methods of making wheels which are quite round, equal in size, and quickly produced. In all some method of rotating either wheel or shaping tool must be devised. A brief description of some of these methods follows :—

TURNED WHEELS.—This is the best method of making wheels, but only where a lathe is available can it be adopted. It is quick, it allows a wide range of decorative treatment to be introduced, and a fine finish may easily be given to the work. A square-sectioned block of wood is first made octagonal by cutting off the corners, after which it is made cylindrical (Fig. 1). For this operation it is fixed to a face plate or screw chuck (Figs. 2 and 3), or it is turned between centres by a prong chuck (Fig. 1). Before a wheel is cut off it may be decorated either by turning or piercing (Figs. 3 and 4). The wheels may be cut off with the parting tool except when turned between centres, when they are almost separated by means of the parting tool and finally removed by sawing. If it is desired to use waste oddments of board these may be held by the screw chuck (Fig. 2).

WHEELS SHAPED BY SCRATCH STOCK.—In this method the wood is held still and the cutter moves round it. The scratch stock is shaped as in Fig. 5. The $\frac{1}{4}$ " metal pin rests in a hole of similar size bored through the centre of the wood. This hole has later to take the axle, and so may have to be enlarged with a drill of suitable size. The cutter, which is a piece of tool steel ground or filed to suitable shape, is held in the stock by a screw or small bolt on each side. Decoration may be added, according to the shaping of the cutter, to one or both sides of the wheel. It may be necessary to cut thick wheels from both sides, perhaps completing the final parting by means of a bow saw and finishing off with chisel or spokeshave. Those unaccustomed to this method will be surprised by the speed and accuracy with which wheels may be fashioned.

BUILT-UP WHEELS.—Wheels may be built up from discs of plywood or other timber. These should be glued and screwed together, care being taken that the grain of the wood in the various discs runs in different directions (Fig. 6). One disc may be placed between two larger discs to form a recess into which a tyre may be fitted (Fig. 7). Such a wheel is that used for the large locomotive on Page 98. A similarly made small wheel but without the tyre forms a pulley (Fig. 8), which may be used for the breakdown lorry on Page 78.

(Continued on Page 68)

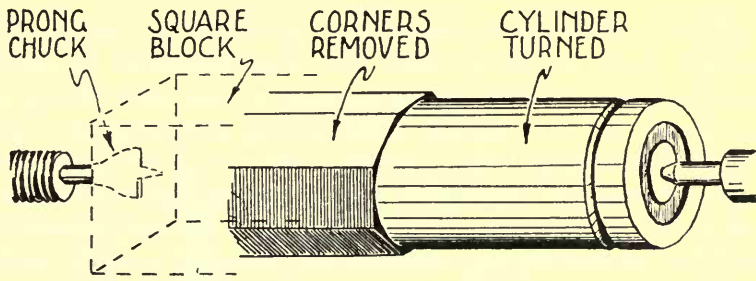

FIG 1 FIRST OPERATIONS AND USE OF PRONG CHUCK

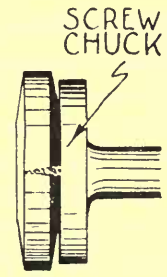

FIG 2

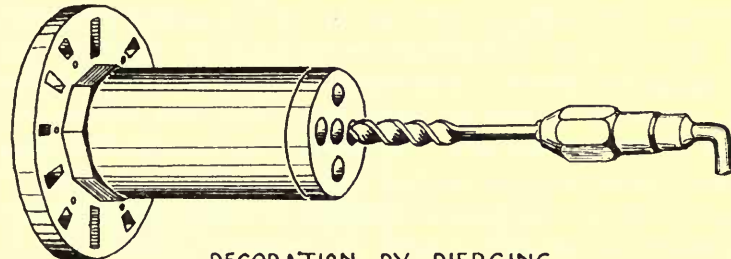

FIG 3 DECORATION BY PIERCING BLOCK MOUNTED ON FACE PLATE

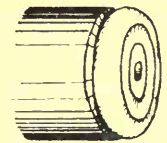

FIG 4 WHEEL WITH TURNED DECORATION

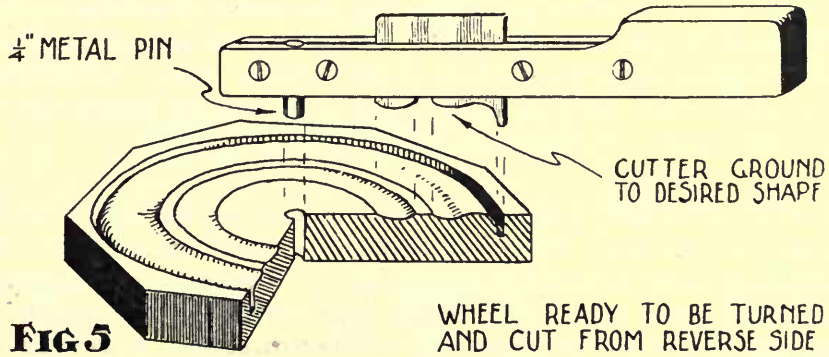

FIG 5

WHEEL READY TO BE TURNED AND CUT FROM REVERSE SIDE

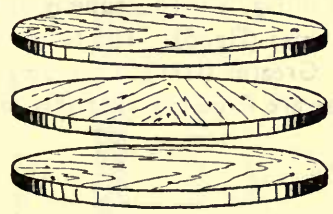

FIG 6 BUILDING UP DISC WHEEL

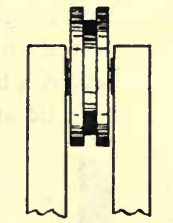

FIG 8 PULLEY FROM DISCS

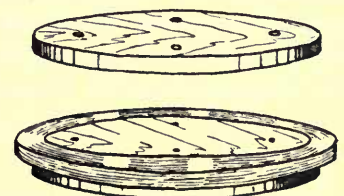

FIG 7 DISC READY FOR SCREWING DOWN OVER TYRE

W H E E L S—continued

GUILLOTINE-CUT WHEELS.—Shaping by means of a guillotine is another quick method of producing wheels. Such wheels are plain, but some decoration by piercing may be added. The guillotine (Fig. 1), which should be made of hardwood throughout, is cheap and easy to construct. Its main feature is the cutting arm to which a plane blade is fixed by two small nuts and bolts (Figs. 1 and 2). This arm is pivoted between two uprights tenoned into the base and controlled near the other end of the arm by another upright in which a slot has been cut. The arm is a close fit both between the uprights and in the slot, thus eliminating any side-play and ensuring a rigidly vertical movement. At right-angles to the blade and across the base is cut a dovetail groove along which slides a slotted piece of wood. This piece of wood accommodates a pin of $\frac{1}{4}$ " mild steel, and is fixed in any required position along the groove by the wing nut of a small bolt passing through the base. A scale set out on the sliding piece and an arrow on the baseboard enables quick adjustments to be made for different sizes of wheels (Fig. 2). Before shaping, the wheel is set out with compasses, a $\frac{1}{4}$ " hole is bored, and most of the "waste" removed by bow or tenon saw. It is then rotated on the pin and pared by the blade on the cutting arm. To protect the baseboard a piece of hardwood may be bored and slipped over the pin and under the wheel and blade. This may be renewed as it becomes worn. To prevent accidents it may be advisable to fit a wooden wedge in the slot above the cutting arm when the guillotine is not in use.

WHEEL-MAKING WITH DISC-CUTTER.—The disc-cutter illustrated in Fig. 3 may be bought cheaply and is very useful for cutting discs for wheels up to about 3" diameter. It may be used in either a drilling machine or an ordinary brace. Adjustment of the cutters is by a small screw. Various forms of this cutter may be bought but they vary very little in their action.

WHEELS FROM TINS AND LIDS.—Very useful wheels may be made from the bases and lids of many common tins. First, with a pair of tin-snips cuts are made along each side of the seam and nearly down to the base (Fig. 4). The seam is bent outwards and cut off, thus making easier the removal of the upper portion of the tin (Fig. 4). The lower portion and the lid are now fitted and soldered together. A strip cut from the waste body of the tin (Fig. 4) is then rolled into a tube as in Fig. 5. This tube is passed through a hole bored in the wheel and is riveted on both sides (Fig. 5). The tube holds the wheel together in the middle and also acts as a bush. Greater strength can be given to the wheel by inserting a wooden disc before lid and base are fixed together (Fig. 5).

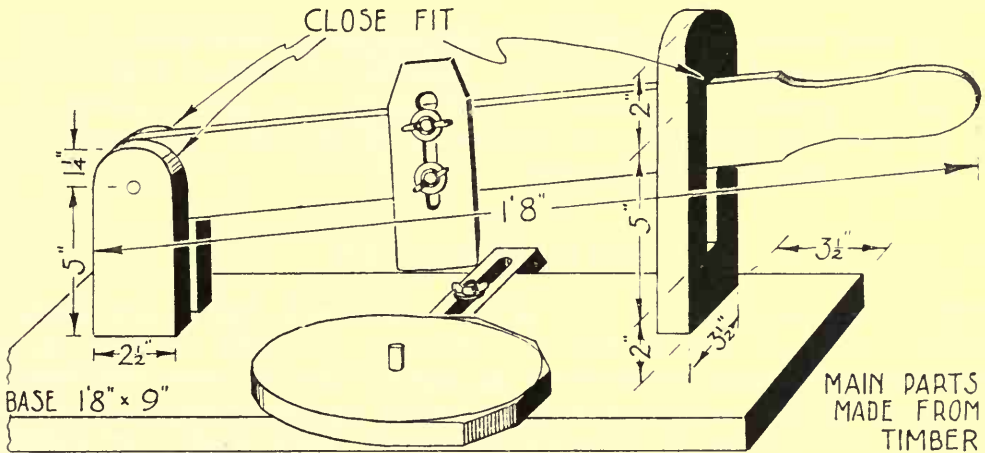

FIG 1 GUILLOTINE WITH DISC PARTLY SHAPED

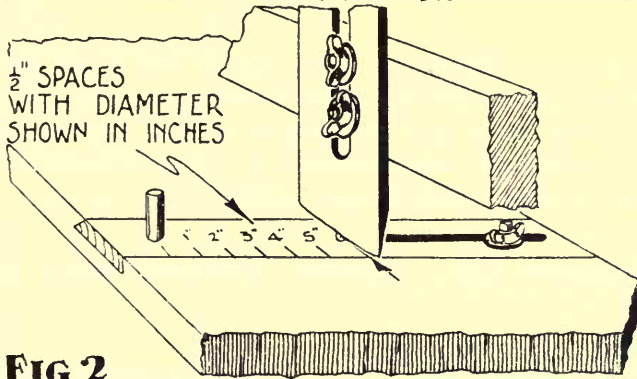

FIG 2 BLADE ATTACHMENT AND DIAMETER INDICATOR

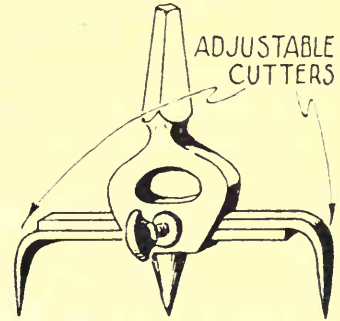

FIG 3 DISC CUTTER

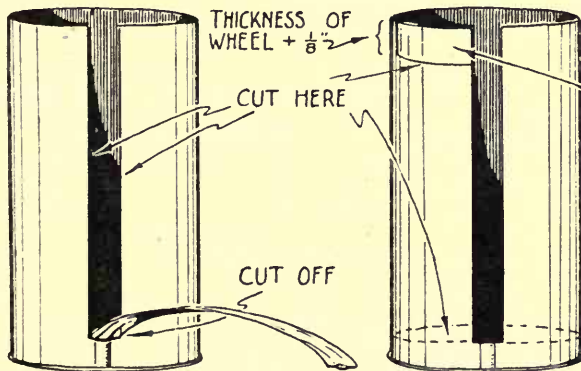

FIG 4 WHEELS FROM TINS

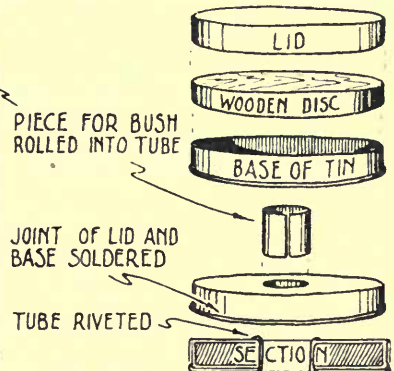

FIG 5 ASSEMBLY OF WHEEL

BREN-GUN CARRIER

This small carrier can be used to transport toy soldiers, small blocks or sand. It is $7\frac{1}{2}$ " long, 4" wide, and $3\frac{3}{8}$ " high. The body and track are made of deal and the wheels of $\frac{1}{4}$ " plywood. Dovetail, tongue and groove, halving, or butt joints may be used in the construction of the body. Butt joints are shown in the illustrations opposite

CONSTRUCTION

BODY.—Cut two sides $5" \times 2\frac{3}{8}" \times \frac{5}{16}"$ with square ends (Fig. 2), then prepare the back $2\frac{3}{8}" \times 2\frac{1}{8}" \times \frac{5}{16}"$ and the front $3" \times 2\frac{3}{4}" \times \frac{5}{16}"$. Carefully cut away the latter for the fitting of the sides, round-off the top edge and bore the three small holes (Figs. 1, 3 and 6). Clean up inside faces and glue and pin together, taking care the whole is "square." To complete the body cut the bottom, which is $4\frac{3}{8}" \times 2\frac{1}{8}" \times \frac{5}{16}"$, then glue and pin it in place (Fig. 1—section). Put aside and allow glue to set.

TRACK PIECES.—Prepare two $7\frac{1}{2}" \times 2\frac{3}{8}" \times \frac{5}{8}"$. From Figs. 1 and 4 set out the shape, then cut out with bow saw or tenon saw and chisel, finishing with file and glass-paper. To suggest links in the track make light saw-cuts at regular intervals across the edge, and with a sharp chisel enlarge each into a shallow "V" (Figs. 1 and 7). Now bore two stopped holes as in Figs. 4 and 7 ready for the wheels.

WHEELS.—Cut four $1\frac{1}{4}"$ in diameter from $\frac{1}{4}"$ plywood. Bore small hole in centre of each.

ASSEMBLY.—Clean up body and track pieces. Drop wheels in position and pin and glue tracks to body. Hold each wheel in place by a small screw passing from track piece through hole in wheel and into body. These should be very carefully inserted so that wheels run freely. Finally paint grey, or camouflage.

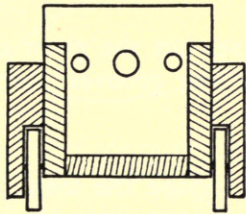
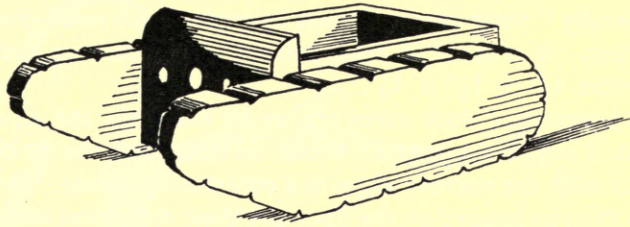

SECTION ON AA

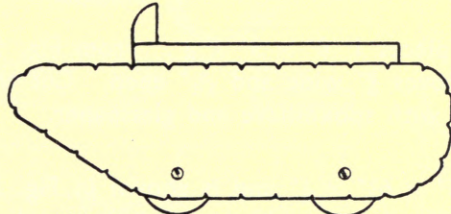
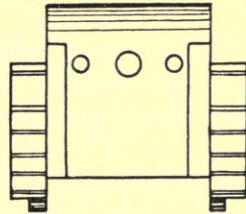

FIG 1 SIDE VIEW



FRONT VIEW

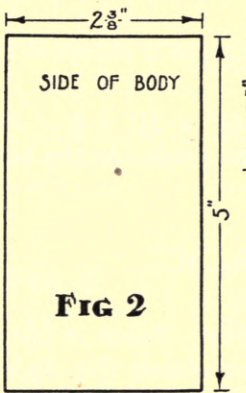

FIG 2

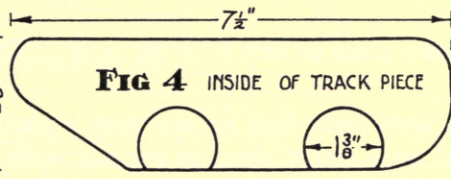

FIG 4 INSIDE OF TRACK PIECE

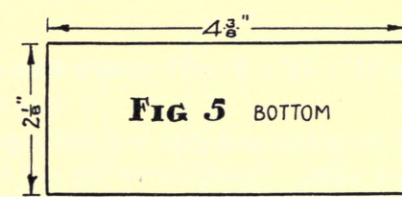

FIG 5 BOTTOM

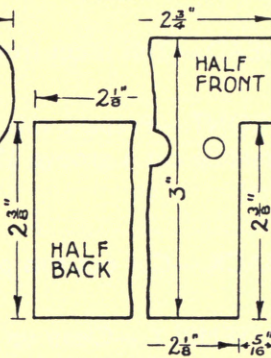

FIG 3

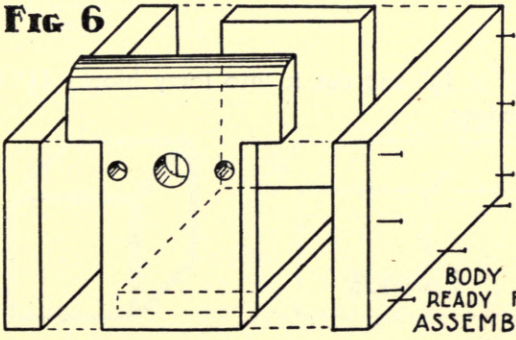

FIG 6

BODY
READY FOR
ASSEMBLY

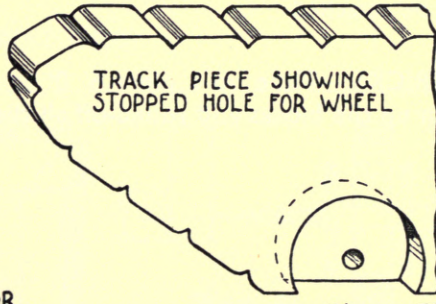

FIG 7

DUCK CART AND BRICKS

This "friendly" little cart is a great favourite with small children, and is easy to construct. It is made in deal, painted in gay colours and filled with forty bright bricks $1\frac{1}{2}'' \times 1\frac{1}{2}'' \times 1\frac{1}{2}''$.

Where a number of duck carts are to be made for the equipping of a large nursery it is suggested that all broad surfaces, and the bricks, be painted in one colour with the narrow edges in a contrasting colour. Bricks from various carts may then be heaped on the floor and their collection into the appropriately coloured carts by the children is both an enjoyable game and a useful colour-training exercise.

CONSTRUCTION

SIDES.—Prepare two pieces $1' 0'' \times 5'' \times \frac{3}{8}''$. From Fig. 1 set out the given shape and the two stopped grooves $\frac{3}{8}''$ wide and $\frac{1}{16}''$ deep. Cut the four grooves, then cut out the curves and finish with spokeshave and glasspaper.

BOTTOM.—This is $11'' \times 6\frac{1}{4}'' \times \frac{1}{2}''$ and is shown in Fig. 3. Shape the front, then mark out and cut the stopped groove $\frac{1}{8}''$ deep for the head.

HEAD.—This is cut from a piece of deal $7'' \times 4\frac{1}{2}'' \times \frac{1}{2}''$. The shape is shown in Fig. 2.

FRONT.—Prepare this with both ends square from a piece $6\frac{5}{8}'' \times 3\frac{1}{2}'' \times \frac{3}{8}''$. Across the middle cut a groove $\frac{1}{2}''$ wide and $\frac{1}{8}''$ deep to register with the groove in the bottom (Fig. 4).

BACK.—Cut out this piece $6\frac{5}{8}'' \times 2\frac{1}{2}'' \times \frac{3}{8}''$ with square ends (Fig. 4).

ASSEMBLY.—Clean up the six pieces and glue and nail together. Punch in the nails. The bottom fits in between the sides. Finally screw on the four wheels (Fig. 6) with a washer on both sides. Into the front of the bottom drive a small staple to which a cord may be attached.

BRICKS.—Plane up a piece $6' 0'' \times 1\frac{1}{2}'' \times 1\frac{1}{2}''$ and cut it into forty blocks $1\frac{1}{2}''$ long. Clean up the blocks and round-off all the edges.

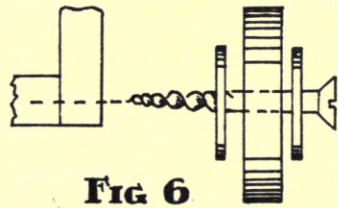
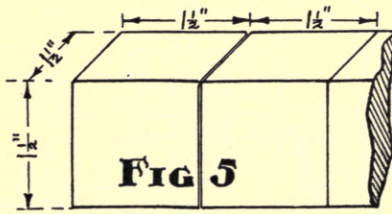
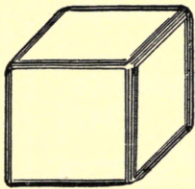
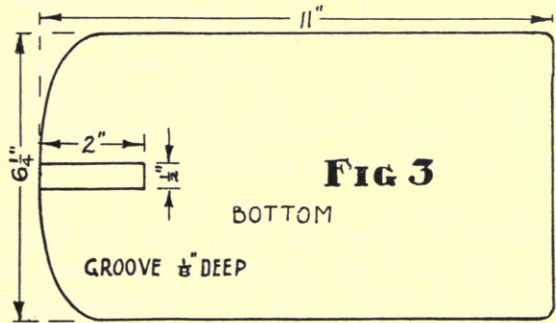
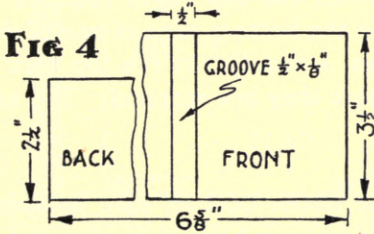
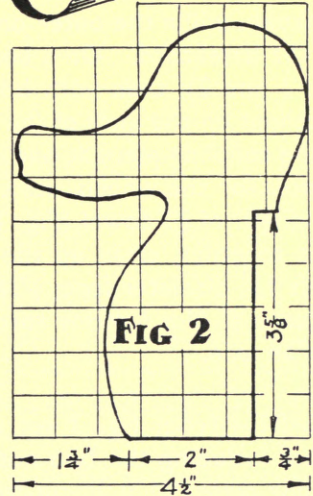
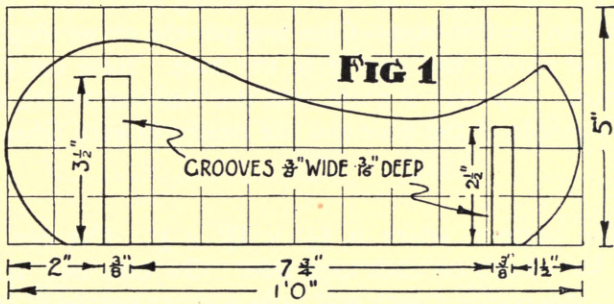
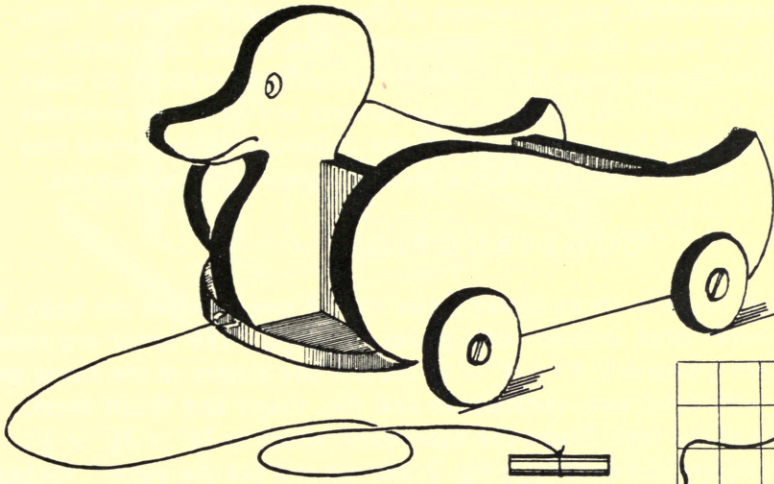

ELEPHANT AND CART

A cart load of bright bricks, the movement of the toy, and a "sleepy" little elephant all help to make this an attractive toy. The bricks are similar to those in the Duck Cart on Page 72. Sufficient should be prepared to make a bright heap in the cart. If a number of elephants and carts are provided and painted as suggested for the Duck Cart the collection of the bricks into their appropriate carts can again be made a pleasing colour-training exercise.

CONSTRUCTION

ELEPHANT.—This is made in three pieces ; the middle one includes the body, head and trunk, while the outer ones include body pieces and legs. The latter are tenoned into the baseboard. On a board $1' 1" \times 4" \times \frac{1}{2}"$ set out the shapes of the three pieces (Figs. 1 and 2), then with bow saw, spokeshave and file, shape and finish them. Cut the tenons on the ends of the legs. Shape the baseboard, which is $7\frac{3}{8}" \times 3\frac{1}{2}" \times \frac{1}{2}"$. Cut out the coupling piece at one end and, from Fig. 2, set out and cut the eight "through" mortises for the wheels and the legs. Bore a $\frac{3}{8}"$ hole in the coupling piece and glue in a 1" length of $\frac{3}{8}"$ dowel (Fig. 1). Clean up the base. Glue and pin the three elephant pieces together, clean up the finished animal and glue it to the base. Now cut eight wheels $1\frac{1}{8}"$ diameter from $\frac{1}{4}"$ plywood. Slip four of these into the mortises in the base and put a $\frac{3}{4}"$ No. 6 screw through the side of the base and the centre of each wheel to act as an axle.

CART.—From Fig. 3 set out the bottom, which is $6\frac{1}{2}" \times 3\frac{3}{4}" \times \frac{1}{2}"$. Cut out the bottom including the two notches for wheels on each long side. On one end screw coupling piece $2\frac{3}{4}" \times 1"$ cut from $\frac{1}{4}"$ plywood and with a $\frac{1}{2}"$ hole with its centre $\frac{5}{8}"$ from the end (Fig. 3). The two ends are $4\frac{1}{8}" \times 2\frac{3}{4}" \times \frac{1}{2}"$ with the top edges rounded and both ends square. Make a notch 1" wide and $\frac{1}{4}"$ deep in the bottom edge of one of them to fit over the coupling piece. Cut four side bars (Figs. 1 and 4). In the top bars the grooves are carried through but in the two bottom bars they are stopped. The angle for the grooves is shown by the thick line in Fig. 1.

ASSEMBLY.—Clean up sides, ends and bars. First fasten bottom bars to bottom of cart. Glue and nail the ends to the bottom and the bottom bars, then glue and nail the top bars in place. Now slip the remaining four wheels into the notches and screw into place as with the elephant.

TIP LORRY

The drawings on the opposite page are of a sturdy tip lorry 1' 2" long and 6 $\frac{3}{4}$ " wide. By turning the small levers on the sides the body is made to rise at the front end while, at the same time, the tail-piece swings open. It can be made in either soft or hard wood.

CONSTRUCTION

BASEBOARD.—This is 1' 2" \times 6" \times $\frac{5}{8}$ ". At one end cut out a piece 7" \times 5" as in Fig. 2.

UNDERFRAMING.—Cut two side pieces 1' 1 $\frac{3}{4}$ " \times 1 $\frac{1}{4}$ " \times $\frac{5}{8}$ " and two end pieces 5 $\frac{1}{4}$ " \times 1 $\frac{1}{4}$ " \times $\frac{5}{8}$ ". Mark out and cut grooving joints as in Fig. 3. Bore a $\frac{1}{4}$ " hole in each side piece 5" from one end. From a piece of $\frac{1}{4}$ " plywood cut a disc 2" in diameter. Bore a $\frac{1}{4}$ " hole $\frac{5}{8}$ " from the edge. This is to take the turning-rod, which is 6 $\frac{3}{4}$ " long. Glue and pin disc to rod. Clean and glue up framing, slipping in turning-rod before fastening on the second side (Fig. 3). Check for squareness. Clean baseboard and screw to framing.

CAB AND BONNET.—From a block 5 $\frac{1}{2}$ " \times 3 $\frac{3}{4}$ " \times 3" shape and finish the cab as in Fig. 4, and from a piece 5" \times 3 $\frac{1}{4}$ " \times 2 $\frac{1}{4}$ " shape the bonnet—see also Fig. 4. Glue and screw both to the baseboard (Fig. 1).

BODY.—Prepare two side pieces 7" \times 3 $\frac{1}{2}$ " \times $\frac{1}{2}$ ", one front 5" \times 3 $\frac{1}{2}$ " \times $\frac{1}{2}$ ", and one loose tail board 4 $\frac{1}{2}$ " \times 3 $\frac{1}{2}$ " \times $\frac{1}{2}$ " (Fig. 5). The bottom is of $\frac{1}{4}$ " plywood 7" \times 5". Join sides and front together by means of butt, halving or dovetail joints. Clean all pieces and glue together, taking care to keep quite square. Glue and pin bottom to sides and front. Now fit in tail board as in Fig. 6.

FINAL ASSEMBLY.—Clean up outside of body, and fit into cut-away portion of baseboard. Bore holes 2 $\frac{1}{2}$ " from the end of the baseboard for pivots. These are two 1" No. 8 screws. Put in screws and fix body in position (see Fig. 1). Shape two levers $\frac{3}{8}$ " thick, bore a $\frac{1}{4}$ " hole in broad end and glue and pin them to the ends of the turning-bar (Fig. 1). Finally, securely screw on wheels and paint as desired.

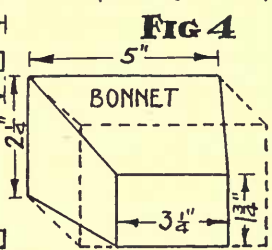
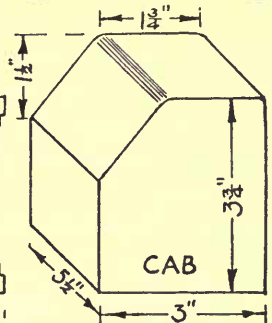
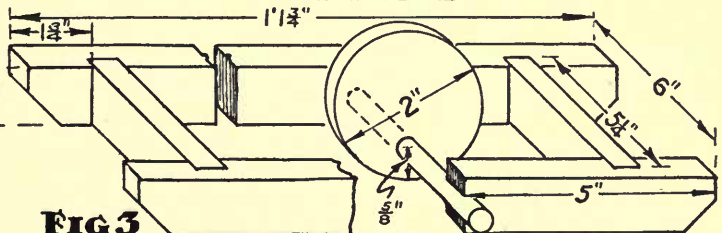
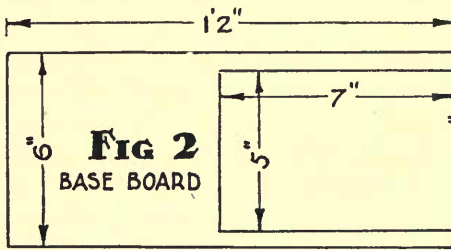
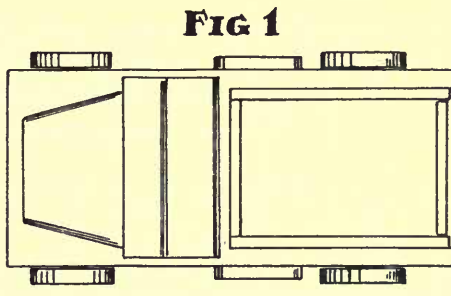
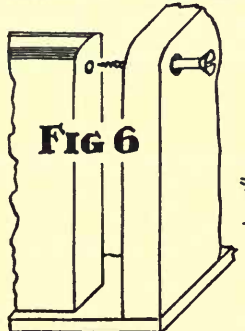
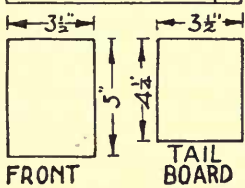
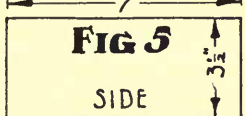
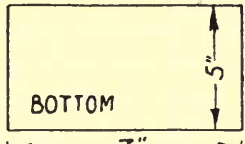
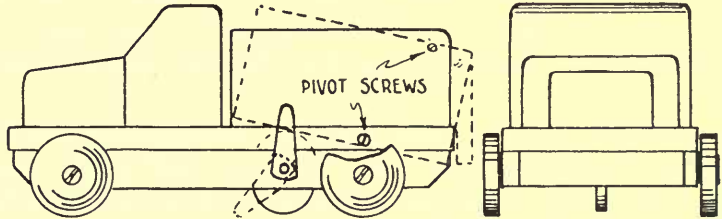
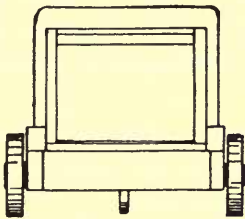
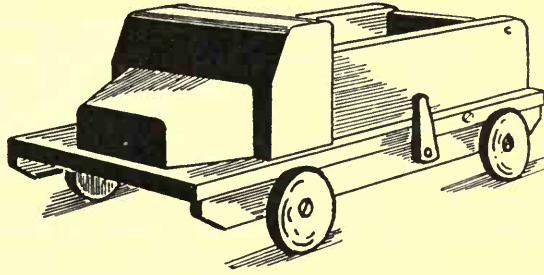

FIG 1

FIG 2
BASE BOARD

FIG 4

FIG 3

BREAKDOWN AND G.P. LORRIES

These two lorries, one a breakdown and the other for general purposes, are a little smaller than the tip lorry, but in construction they are very similar. They may be made in either hard or soft wood.

CONSTRUCTION

BASEBOARD.—This is $1' 1" \times 5" \times \frac{5}{8}"$ and is square at both ends.

UNDERFRAMING (Fig. 2).—Cut two side pieces $1' 0\frac{3}{4}" \times 1\frac{1}{2}" \times \frac{5}{8}"$ and two cross pieces $4\frac{1}{4}" \times 1\frac{1}{2}" \times \frac{5}{8}"$. Mark out and cut a groove $\frac{5}{8}"$ wide and $\frac{1}{4}"$ deep 2" from each end of the side pieces. Bevel the ends of the side pieces. Clean up all pieces, glue and nail together carefully, keeping frame quite square. Screw baseboard to framing.

CAB AND BONNET.—The cab is $4\frac{1}{2}"$ wide, 4" high and 3" thick, tapered as shown in Fig. 1. The bonnet is 4" wide, $3\frac{1}{4}"$ long and 2" thick, tapering to $2\frac{1}{4}"$ wide and $1\frac{3}{8}"$ thick at the front. Clean up both pieces and fix by screws through base.

BODY.—For the body of the general-purposes lorry make, from $\frac{1}{2}"$ material, a shallow bottomless box with outside measurements of $6\frac{3}{8}" \times 4\frac{1}{4}" \times 2"$. Use halving (Fig. 4), tongue and groove (Fig. 5), or dovetail joints. Clean up and fasten to base. Note that the measurements given in the sketches opposite must be adjusted to suit kind of joint used.

For the breakdown lorry, fasten two pieces $3\frac{1}{2}" \times 1\frac{3}{8}" \times \frac{1}{2}"$ to the base, as in Fig. 1.

CRANE.—From a board 4" wide and $\frac{3}{8}"$ thick shape two side pieces, as Fig. 3, with the grain of the wood running **along the arm**. Cut a spacing piece $\frac{3}{4}"$ thick (Figs. 3 and 6). At the top of each side of the crane drill a small hole for the pulley axle and a $\frac{1}{4}"$ hole for axle of winding gear. To make the pulley wheel, cut two plywood discs $1\frac{1}{2}"$ diameter. Bevel one side of each and glue together (Fig. 3). Bore a hole for the axle.

For the winding gear cut two $\frac{1}{4}"$ thick wheels, $1\frac{1}{2}"$ diameter and bore $\frac{1}{4}"$ holes through the centre for the axle. The latter may be a piece of dowel rod $2\frac{1}{4}"$ long. Drill holes and glue in short lengths of thin dowel rod as handles. Place axle in position, glue on the wheels, then fix crane in position by screws through base.

COMPLETE by screwing on wheels, with small washer on each side, and paint suitably.

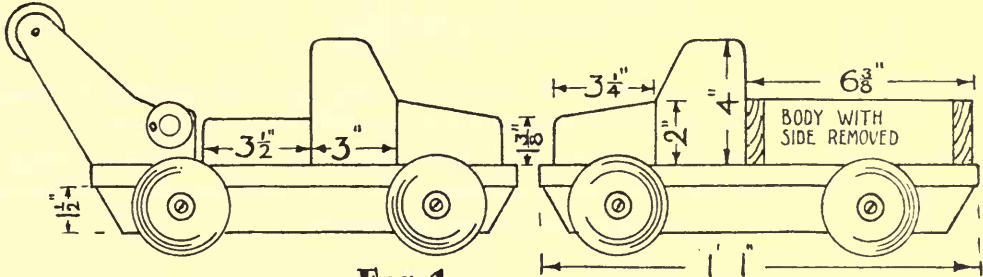
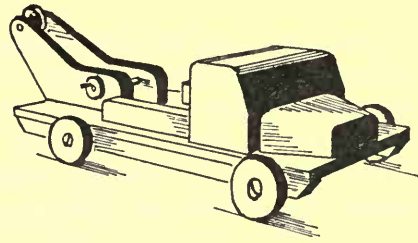
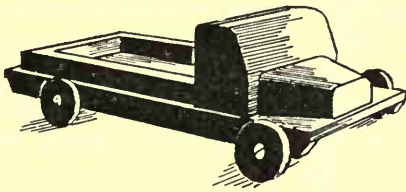

FIG 1

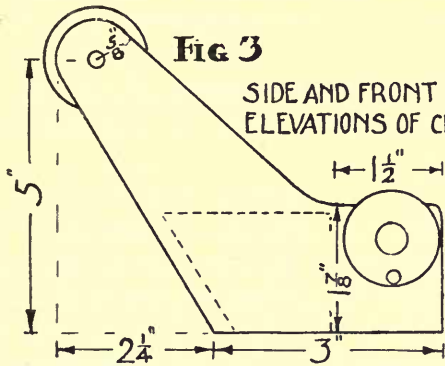
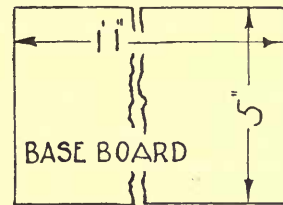
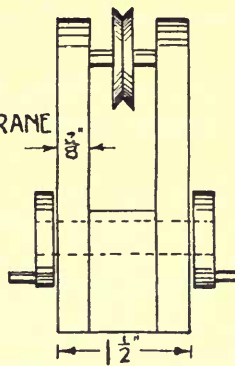
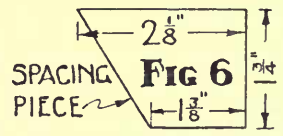

FIG 3

SIDE AND FRONT ELEVATIONS OF CRANE



BASE BOARD



SPACING PIECE

FIG 6

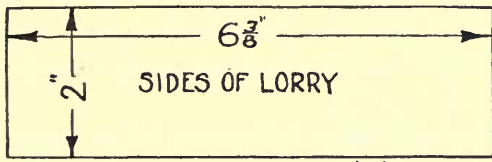

SIDES OF LORRY

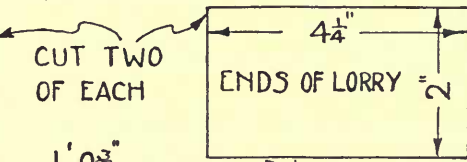

CUT TWO OF EACH

ENDS OF LORRY

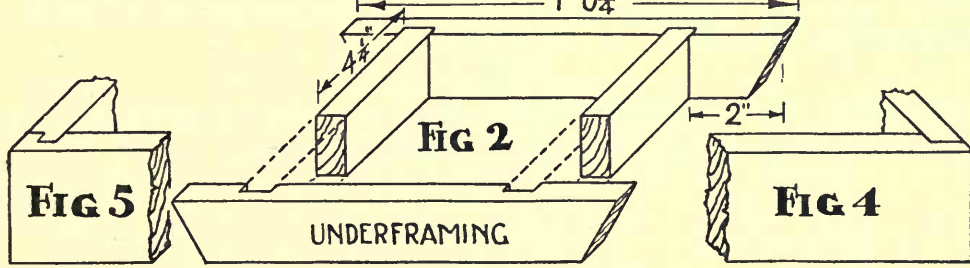

FIG 2

UNDERFRAMING

FIG 5

FIG 4

SCOOTER

To a child a scooter not only gives pleasure, it also helps to develop confidence and a valuable sense of balance. The scooter illustrated opposite is strong, pleasing in appearance, and easy to construct. Note that the length of the notches cut in the footboard and steering-piece depends upon the diameter of the wheels. In width the notches must be equal to the thickness of the wheels plus a little for clearance.

CONSTRUCTION

FOOTBOARD.—From a board 2' 0" \times 5" \times 1" mark out the footboard shown in Fig. 2. Cut the notch for the rear wheel and the mortice for the front block. Cut the curves at the rear end and the bevels at the front. From Fig. 4 set out and shape the block shown. The angle for the front is shown in Fig. 4, by a thick line. Fit the block to the footboard, clean up and glue and screw in position.

STEERING-PIECE.—This is 2' 0" \times 3" \times $\frac{7}{8}$ ". On one end mark out the notch for the front wheel, and at the other end a $\frac{1}{4}$ " tenon. Cut notch and tenon (Fig. 3).

HANDLE.—For this, prepare a piece 11" \times 2" \times $\frac{7}{8}$ ". In the centre set out a mortice 3" \times $\frac{1}{4}$ ". Cut the mortice and shape the handle as Fig. 5. Clean up and glue handle to steering-piece.

BRACKETS.—Shape these from two pieces of $\frac{3}{4}$ " \times $\frac{1}{8}$ " mild steel. They are 4" long with arms at right angles and 1 $\frac{1}{2}$ " long. Two holes $\frac{5}{16}$ " in diameter are drilled, one in each arm, for the pivot bolt. If an actual bolt is used for this, its end should be riveted slightly after assembly so that the nut does not shake off. If a piece of $\frac{5}{16}$ " mild-steel rod is used, it should be held in a vice and a head shaped on it. At the other end a small hole should be drilled and a split pin inserted. In the back of each bracket drill two or three $\frac{3}{16}$ " holes, then screw one bracket to the block and one to the steering-piece (Fig. 3).

WHEELS.—These run on $\frac{1}{4}$ " or $\frac{3}{8}$ " bolts or rod which, again, should be riveted. If wheels are to be made, a suitable wheel is that used for the locomotive on Page 98. The wheels should be "bushed."

ASSEMBLY.—Clean up all parts, mount wheels with a thin washer on each side, and bolt footboard and steering-piece together. Varnish or paint as desired.

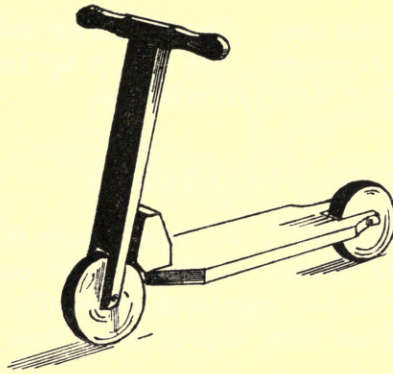
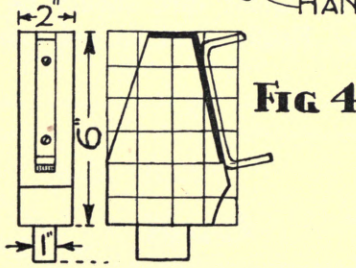
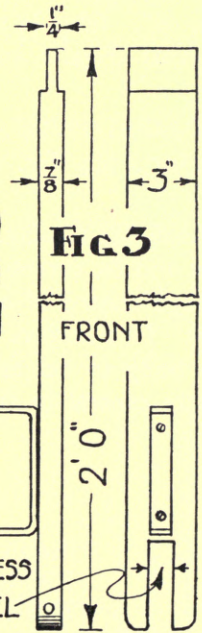
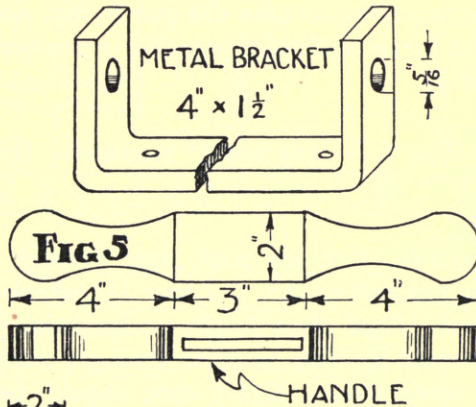
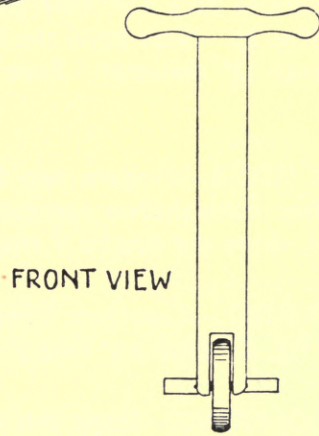
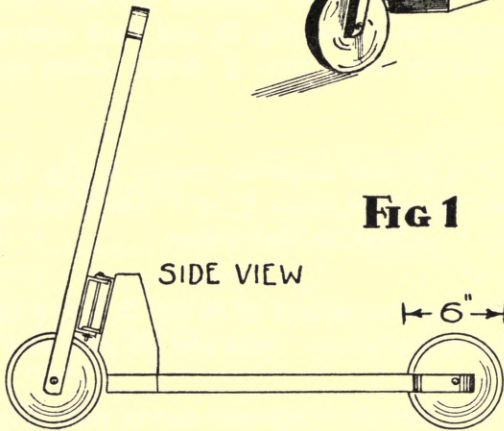

FIG 1



TANK

Realism is the keynote of this tank. The gun turret swivels while the gun itself may be elevated or depressed. The tank is $8\frac{1}{2}$ " long, 5" wide and 5" high. Any soft wood will do for its construction.

CONSTRUCTION

BODY.—This is one piece $7\frac{1}{2}$ " \times $3\frac{1}{4}$ " \times 3". Square both ends. Through the centre on the underside bore a 1" hole $\frac{5}{8}$ " deep. With a $\frac{1}{2}$ " bit continue the hole through the block (Fig. 2). Next bevel the four corners as shown (Fig. 2), and mark centres for wheel sockets $1\frac{3}{8}$ " diameter. Bore these slightly more than $\frac{3}{8}$ " deep. Clean up the block.

TRACK PIECES.—Prepare two $8\frac{1}{2}$ " \times 3" \times $\frac{7}{8}$ " and shape as shown in Fig. 3. To get link effect make shallow saw-cuts across the pieces about $\frac{3}{4}$ " or 1" apart and, with a sharp chisel, shape the cuts to V shape—Fig. 1. Clean up both pieces.

GUN TURRET.—Construct from two side pieces shaped as in Fig. 5, and a centre block as in Fig. 4. Bore a $\frac{1}{2}$ " hole $\frac{3}{4}$ " deep for end of pivot. Glue and pin sides to block.

GUN MOUNTING.—Shape this as in Fig. 6 and fit it between turret sides (Fig. 1). Bore a $\frac{1}{2}$ " hole in the mounting to take the gun barrel, which is 3" long, tapering from $\frac{1}{2}$ " to $\frac{5}{16}$ ". Glue in the barrel and hold mounting in position with two fine screws acting as pivots (Figs. 1 and 5).

TURRET PIVOT.—This is 3" long and $\frac{1}{2}$ " diameter. Drill a small hole, $\frac{1}{4}$ " from one end, for a pin (Fig. 1).

ASSEMBLY.—Fix pin in pivot and push pivot through hole in body. Glue end of pivot and fix turret in position on it. Cut four $1\frac{1}{4}$ " wheels $\frac{3}{8}$ " thick and drill small hole through centre of each. Place these in the sockets and glue and pin track pieces to body. Fine screws should now be inserted through track, centre hole of wheel, and into body to act as wheel axles. Great care should be taken that the wheels are exactly central in their sockets. Finally clean up and camouflage.

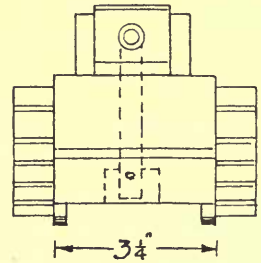
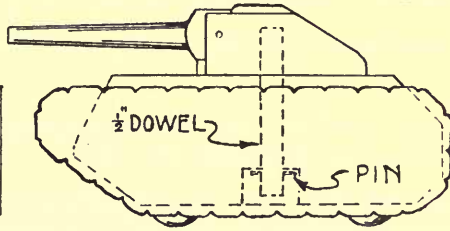
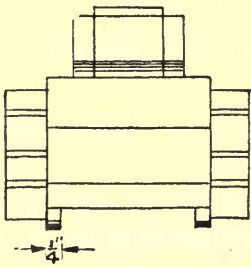
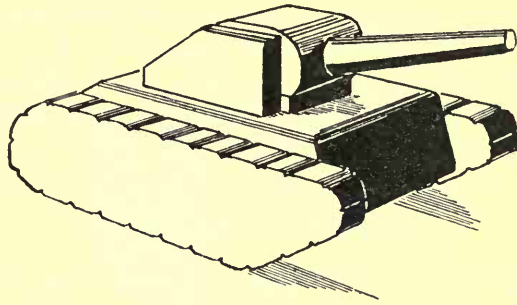

FIG 1

FIG 5
SIDE OF TURRET

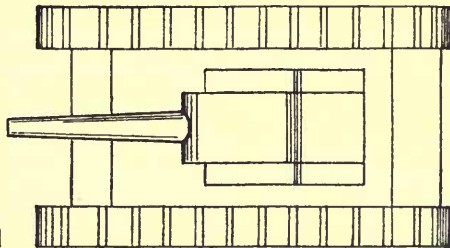
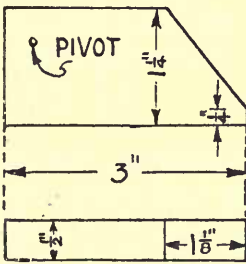

FIG 4
CENTRE OF TURRET

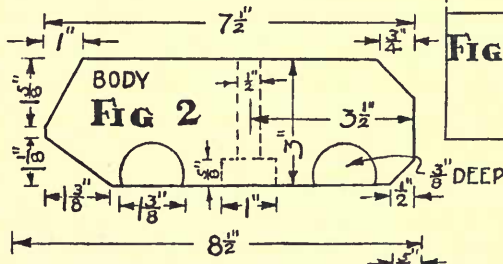
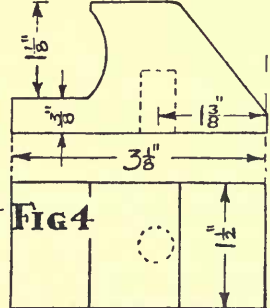

FIG 2
BODY

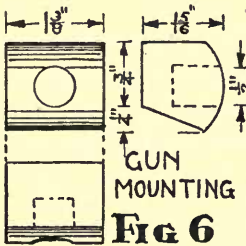

FIG 6
GUN MOUNTING

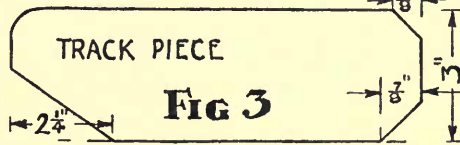
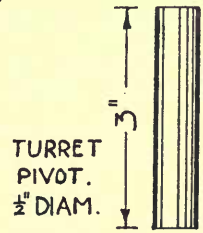

FIG 3
TRACK PIECE



TURRET PIVOT.
1/2" DIAM.

H O R S E O N W H E E L S

This horse has other qualities apart from its value as a toy ; when stored away its shelves can accommodate small toys, whilst the tail bar is an excellent support for the small child learning to walk.

For some small children the top of the horse may be a little wide; an alternative form is therefore shown on Plate III. Here the ends are tapered and the top reduced in width from 6" to 4½"

C O N S T R U C T I O N

BODY.—This is 20" × 13½" × 6" with a "shelf" 4" × ⅞" along the centre. Prepare top and bottom to a finished size of 20" × 6" × ⅞" (Fig. 4), and two end pieces 13½" × 6" × ⅞" (Fig. 5). All four pieces should be finished quite square.

Set out dovetails for top and bottom as in Fig 3. Cut out joint and fit together "dry." Number the joints.

Prepare shelf 20" × 4" × ⅞", then set out and cut tenons (Fig. 6). Make saw-cuts diagonally along tenons for insertion of wedges (Fig. 2).

Across the middle of both ends draw two lines ⅞" apart and set out mortises between these lines as in Fig. 5. Working from both sides so as to prevent splitting, cut the four mortises and fit the shelf.

Clean up the inner sides of top, bottom and both ends, as well as the four sides of the shelf. Glue up, check for squareness, glue and insert wedges, and put aside to set.

HEAD AND TAIL.—From Fig. 2 by squares mark out the head on a board 13" × 10" × 1½" and then cut out and clean up ready for fitting. Cut tail piece as Fig. 9, bore ⅜" hole for bar, and clean up.

WHEELS.—The large wooden wheels—5" to 6" diameter—should be bushed (see Page 64) and mounted on ⅜" round mild-steel axles. They should have washers on each side and be held on by split pins. The axles are held to the body by pieces of hardwood grooved, as in Fig. 7. For these prepare a piece 12" × 1¾" × ⅝" and plough along the centre a groove ⅜" × ⅜". Cut into two lengths of 6" each.

ASSEMBLING AND FINISHING.—When the glue has set, clean up the body all round and set out and cut the stopped grooves for the head. Fit and screw the head and tail in position. Round off the edges of the seat. Attach the wheels by screws through the two grooved pieces. Glue the short bars (Fig. 8) in the holes in head and tail, and finish with varnish or two coats of paint.

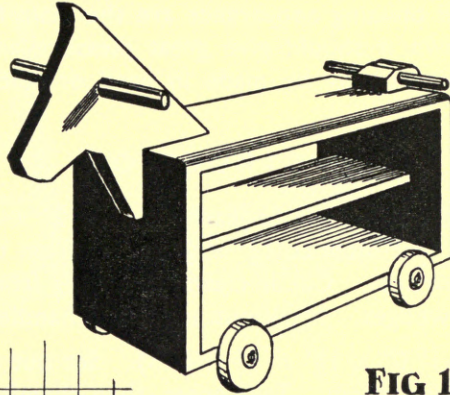

FIG 1

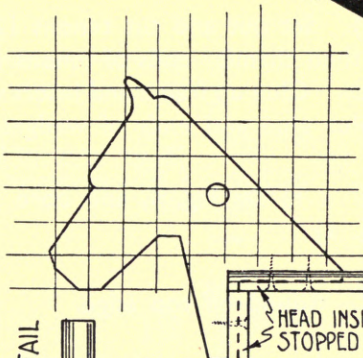

FIG 2

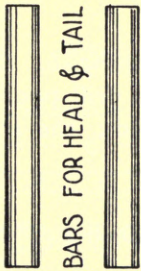

FIG 8

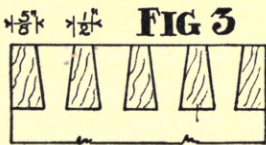
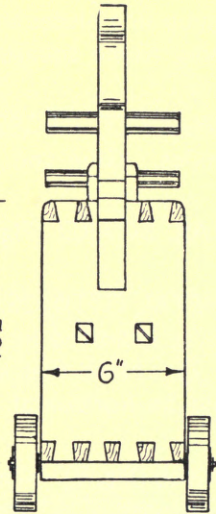
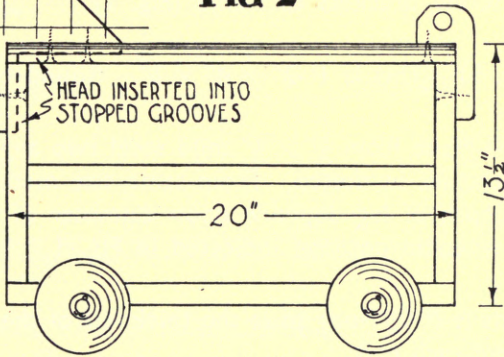

FIG 5

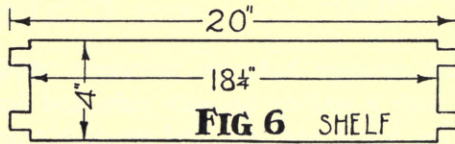

FIG 6 SHELF

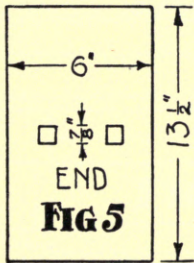

FIG 7

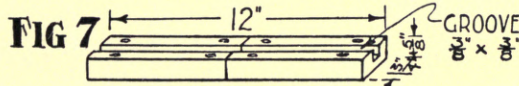

FIG 8

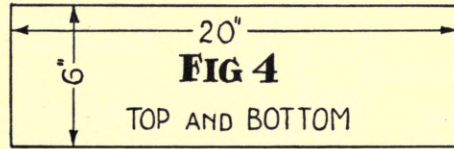

FIG 9

TOP AND BOTTOM

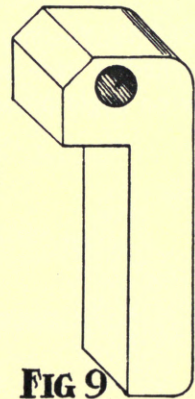

FIG 9

SACK TRUCK

Sturdiness, utility and pleasing appearance are the main features of this toy. If constructed as shown it should give great pleasure and withstand rough usage for many years. It may be made in hard or soft wood.

CONSTRUCTION

FRAMING.—Prepare two side pieces each $2' 6" \times 2" \times 1\frac{1}{4}"$. Starting from one end of each, mark out the first mortice $1\frac{1}{2}" \times \frac{1}{2}"$ and $1"$ from the end. From Fig. 2 set out the remaining three mortices. Cut all cleanly, working from both sides, and enlarge on the outside of each for wedges. Mark out and shape handles $8"$ from other end.

Prepare four rails each $1' 0" \times 1\frac{1}{2}" \times \frac{3}{4}"$ (Fig. 3). Set out and cut tenons $1\frac{1}{2}"$ long. Fit joints "dry," then number them. Take apart, then chamfer ends of tenons (Fig. 3). Clean up side pieces and rails. Cut sixteen $\frac{1}{2}"$ wedges. Glue up frame and insert wedges, keeping frame square and "flat." Clean off surplus glue and ends of wedges.

BRACKET PIECES.—Shape two pieces $7" \times 1\frac{1}{2}" \times 1\frac{1}{4}"$ as Fig. 4, and bore $\frac{3}{8}"$ hole for axles. Glue and screw brackets to frame (Fig. 1).

TAIL BOARD (Fig. 5).—This is $1' 2" \times 4" \times \frac{1}{2}"$. Round off top edge.

METAL FITTINGS.—Make from $\frac{3}{4}" \times \frac{1}{8}"$ mild steel two angle pieces as Fig. 6. Drill holes as indicated by crosses in sketch. From same size metal bend and drill two legs (Fig. 7). Note that depth of leg depends upon diameter of wheels used; the truck should be horizontal when in position indicated in Fig. 1.

AXLE (Fig. 8).—This is $1' 0\frac{3}{8}"$ long plus the thickness of the wheels. Drill a $\frac{3}{16}"$ hole at a distance of $\frac{3}{16}"$ from each end.

ASSEMBLY.—Slip axle through holes in brackets. Add the wheels, which should be bushed at each end with a washer on each side, and fasten with split pins (Fig. 8). Screw on angle pieces, tail board and legs, and truck is ready for painting.

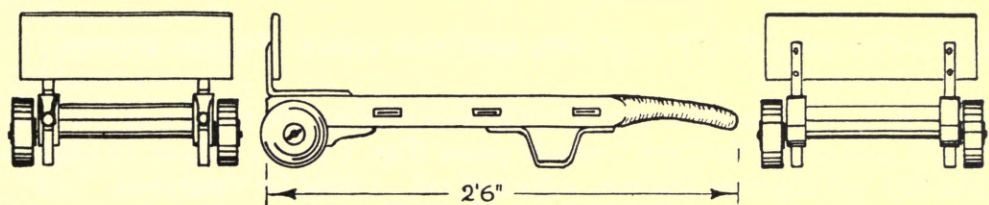
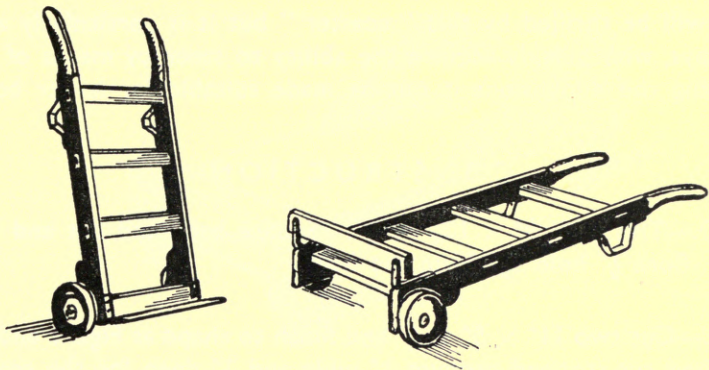

FIG 1

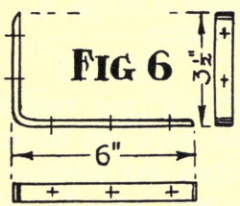

FIG 6

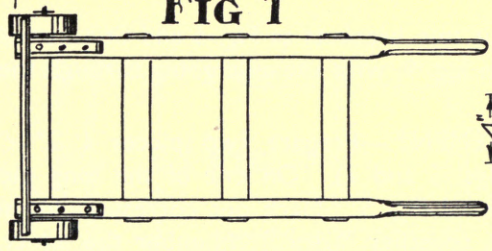

FIG 2

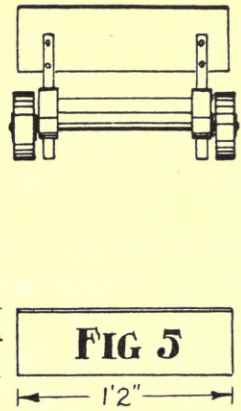

FIG 5

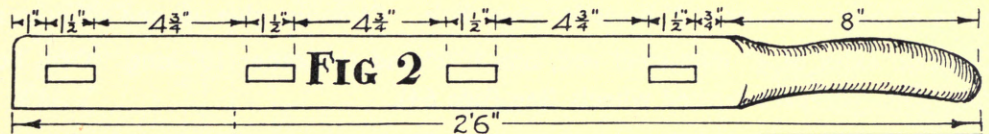

FIG 3

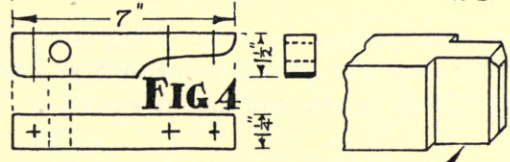

FIG 4

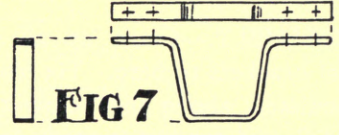

FIG 7

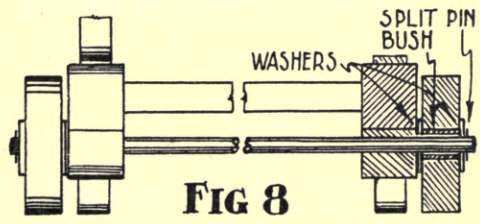

FIG 8

C O A S T E R

Any child will be thrilled by this "coaster" but it is particularly attractive to small boys, who quickly acquire the ability to steer by means of the feet. By increasing the dimensions it can be made suitable for larger boys.

CONSTRUCTION

BASEBOARD.—This is $1' 9" \times 10\frac{1}{4}" \times \frac{7}{8}"$. Square back and cut and finish front to curve of Fig. 3. Bore $\frac{1}{2}"$ hole $2\frac{1}{2}"$ from the front.

SIDE PIECES.—Cut two $11" \times 5" \times \frac{3}{4}"$ and finish to shape as Figs. 1 and 4. On inside faces mark out and cut stopped grooves $\frac{1}{2}"$ wide and $\frac{1}{4}"$ deep for the seat (Fig. 4).

SEAT.—One piece $9" \times 7" \times \frac{1}{2}"$ with both ends square. Fit into grooves.

BACK RAIL.—This is $10" \times 1" \times \frac{3}{4}"$. On both ends cut the tail of a dovetail halving joint. Cut sockets and fit "dry" to side pieces (Figs. 1 and 4). Clean up inside faces and glue and nail together the seat, sides and rail. Check for squareness.

BACK WHEELS.—Cut two brackets as Fig. 6 and fit to baseboard as in Fig. 8. The wheels are mounted as in Fig. 9, with the axle going through the bracket.

FRONT AXLE MOVEMENT.—Prepare two pieces $1' 2" \times 2" \times \frac{7}{8}"$ and two side pieces $4\frac{3}{4}" \times 2" \times \frac{7}{8}"$ (Figs. 5 and 7). On one of the long pieces mark out dovetails and on the other tenons, as Fig. 5. Mark out corresponding sockets and mortices on side pieces. Cut and fit together "dry." Number the joints. Bore holes for axles. In centre of long pieces bore $\frac{3}{8}"$ holes for pivot bolt. Clean up, glue up, and allow to set.

Cut two axles of $\frac{3}{8}"$ mild-steel rod, one $1' 2"$ and the other $10"$ long. Drill holes for split pins. Prepare bushed wheels (see Page 64).

ASSEMBLY.—Clean up all parts. Screw seat portion to base. Glue and screw wheel brackets to base. Fix front movement in place with $\frac{3}{8}"$ bolt and with large washer immediately above and below the baseboard. Slide in axle and mount wheels as Figs. 1 and 9, and coaster is ready for painting.

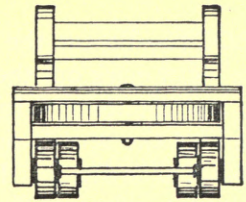
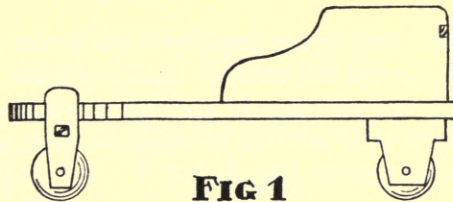
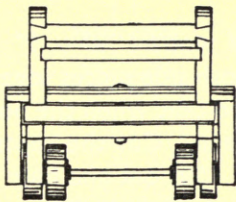
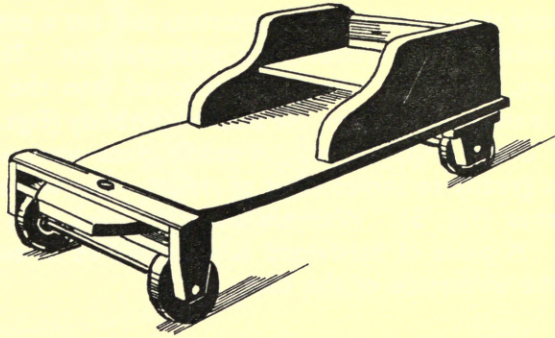

FIG 1

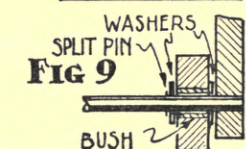
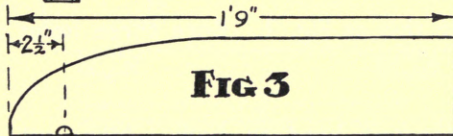
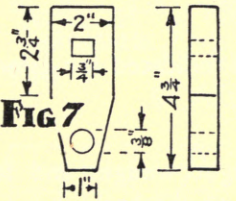
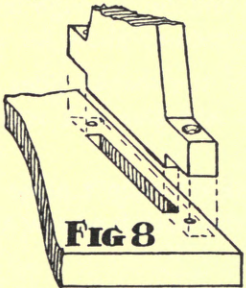
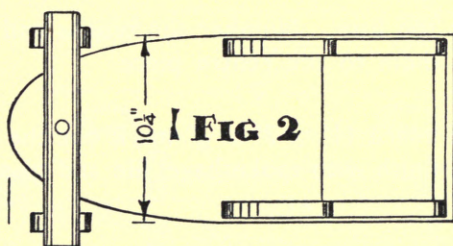
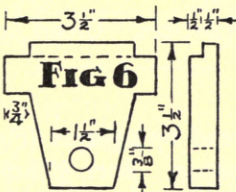

FIG 2

FIG 3

FIG 8

FIG 9
WASHERS
SPLIT PIN
BUSH

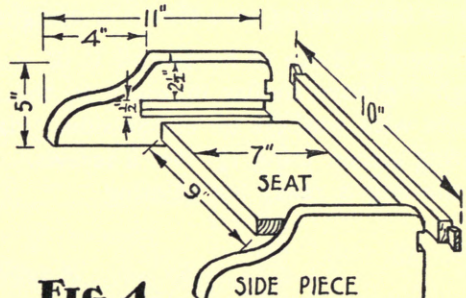
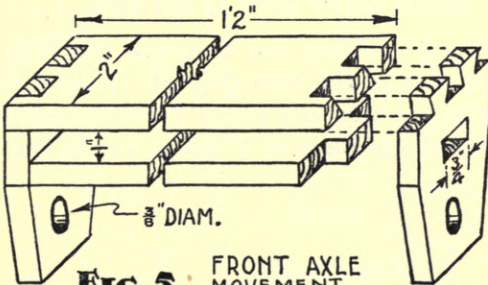

FIG 5 FRONT AXLE MOVEMENT

FIG 6

SEAT
SIDE PIECE

DOG ON WHEELS

This toy is very strong, simple to construct, and has a pathetic and appealing look which makes it very attractive to most children. Three pieces of board form the body, the outer two being tenoned into the base. The head is separate and is screwed between the sides of the body (Figs. 1 and 7). Through it passes a $\frac{3}{4}$ " dowel gripping bar. A saddle piece screwed to the back (Figs. 1 and 2) adds greatly to the comfort of riding. The wheels are of wood with $\frac{5}{16}$ " or $\frac{3}{8}$ " bushes (Fig. 5). Washers and split pins hold the wheels to the metal axles. A piece of hardwood is ploughed to fit over the axles and is screwed to the underside of the base.

CONSTRUCTION

BODY.—To cut the two sides fasten together two pieces of wood $1' 2" \times 9" \times \frac{7}{8}"$. From Fig. 4 mark out the shape and the tenons. Cut and finish both side pieces together. Bore and countersink four $\frac{1}{4}"$ screw holes in each piece, so placed that when the body is assembled the screws on each side will not be opposite each other. Cut the centre or tail piece as in Fig. 3. The baseboard (Fig. 6) is $1' 9" \times 6" \times \frac{7}{8}"$. Set out the four mortices and cut through from both sides. The mortices should be enlarged a little on the underside to allow for wedges. Round off the four corners of the base.

Fit the shaped sides to the base. Number the tenons and mortices. Clean up the sides and glue and screw them to the centre piece.

HEAD.—On a piece of board $11" \times 7" \times \frac{7}{8}"$ mark out the head by squares (Fig. 7). Cut out with bow saw and finish with spokeshave, file and glasspaper. Bore $\frac{3}{4}"$ hole for rod.

SADDLE PIECE.—Shape this as Fig. 2. Bore three holes as indicated for attaching to body.

ASSEMBLY.—Glue and screw head to body. Now cut eight wedges and fasten body to base, taking care that it is upright. Screw saddle piece to the back.

Prepare a piece of hardwood $1' 0" \times 1\frac{1}{4}" \times \frac{5}{8}"$. Along the centre of the wide side plough a groove similar in width to the diameter of the axle (Fig. 5). Mount wheels on axle with washers on either side. Place in position and screw down the ploughed covering pieces, using $1\frac{1}{4}"$ No. 8 screws. Glue the $6"$ piece of $\frac{3}{4}"$ dowel rod in the head and the dog is ready for painting.

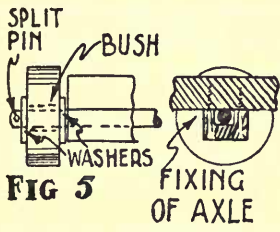
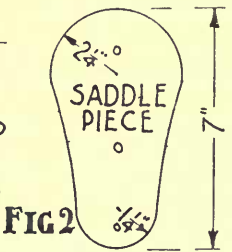
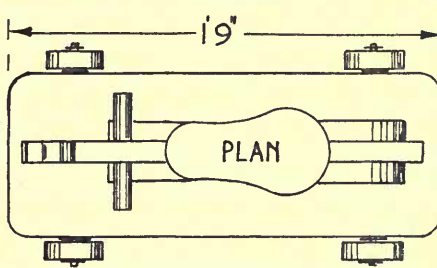
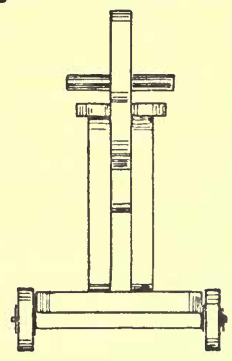
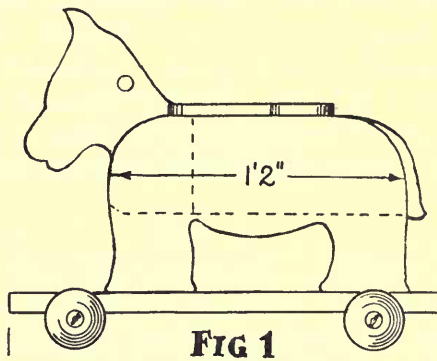
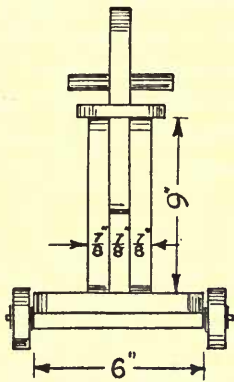
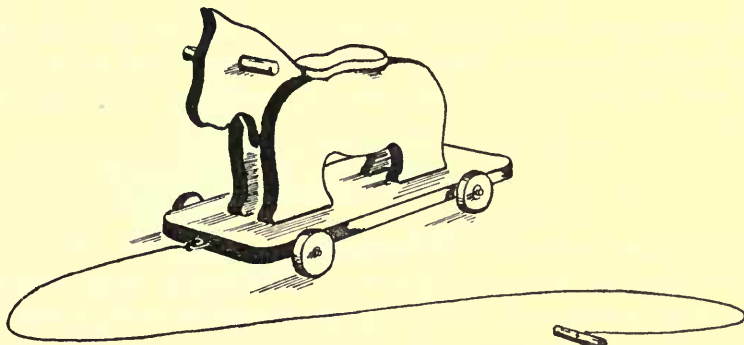

FIG 5

FIXING OF AXLE

FIG 2

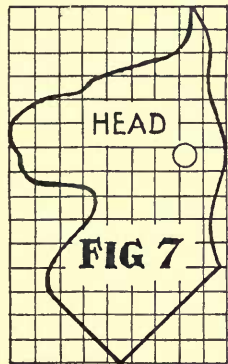

FIG 7

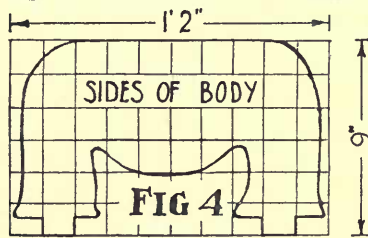

FIG 4

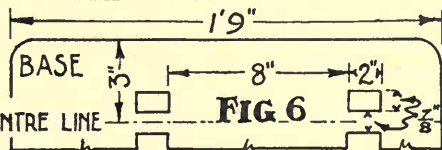

FIG 6

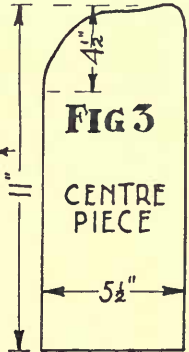

FIG 3

CENTRE PIECE

NOAH'S ARK

Unlike most arks, this one is mounted on four wheels and has couplings behind for the animals on Page 94 to be linked up, "two by two," and drawn along with the ark. It is 1' 8 $\frac{1}{2}$ " long, 9 $\frac{1}{2}$ " wide and 1' 0" high, and is made of deal.

CONSTRUCTION

HOUSE SECTION.—Prepare two **sides** (Fig. 4) each 1' 1" \times 5" \times $\frac{1}{2}$ ". At a distance of $\frac{1}{4}$ " from the ends of each, cut a groove $\frac{1}{4}$ " wide and $\frac{1}{4}$ " deep. Prepare also the two **ends** of the house, which are 7" \times 5 $\frac{1}{4}$ " \times $\frac{1}{2}$ " and shaped as in Fig. 2 with a $\frac{1}{4}$ " \times $\frac{1}{4}$ " tongue on the edges. Fit the ends to the sides, clean up and glue and nail together, keeping the whole square. Cut the **deck** 1' 7" \times 7 $\frac{7}{8}$ " \times $\frac{1}{2}$ " (Fig. 6). Clean up and screw to the sides and ends of the house with 1" No. 8 screws. The **roof** is loose with one side 1' 2" \times 5" \times $\frac{3}{8}$ " and the other 1' 2" \times 4 $\frac{5}{8}$ " \times $\frac{3}{8}$ ". From $\frac{1}{4}$ " plywood shape two ends or "**barge boards**," as Fig. 8. Glue and pin together the two sides of the roof, then glue and pin the barge boards in place. Finally glue blocks along the angle of the roof as in Fig. 1 (section).

BOAT SECTION.—Cut and shape two **sides** 1' 8 $\frac{1}{2}$ " \times 4 $\frac{1}{2}$ " \times $\frac{1}{2}$ " with $\frac{1}{4}$ " \times $\frac{1}{4}$ " grooves across the ends (Figs. 1 and 7). Cut two **ends** with $\frac{1}{4}$ " \times $\frac{1}{4}$ " tongues on the sloping edges (Fig. 3). Fit together sides and ends, then cut the **bottom**, which is 1' 5" \times 6 $\frac{1}{2}$ " \times $\frac{1}{2}$ ". From Fig. 5 mark out and cut the four through mortices for the **wheels**, which are 1 $\frac{3}{8}$ " diameter and $\frac{3}{8}$ " thick. Mount the wheels on axles held by a covering piece screwed to the bottom (Fig. 8). Clean up, then screw sides and ends to bottom. Around the sides and ends screw a $\frac{1}{2}$ " \times $\frac{1}{2}$ " strip to support the deck (Figs. 1 and 7).

Finally, prepare two pieces 4" \times 1" \times $\frac{3}{8}$ ", then $\frac{5}{8}$ " from one end of each, bore a $\frac{1}{4}$ " hole and glue into this a 1" length of $\frac{1}{4}$ " dowel. Glue and screw these pieces to the bottom (Fig. 1).

Complete by painting suitably. Windows, doors, etc., may be painted in as shown in sketch at top of page opposite.

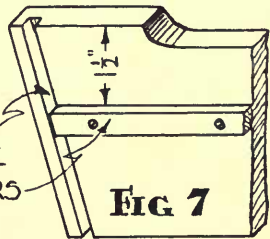
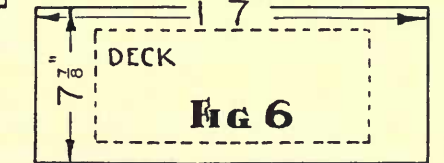
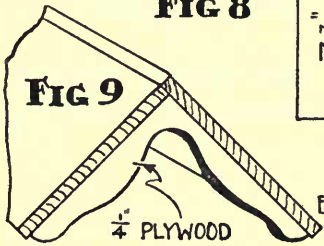
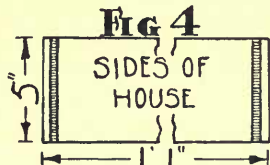
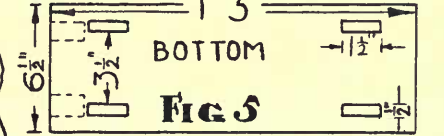
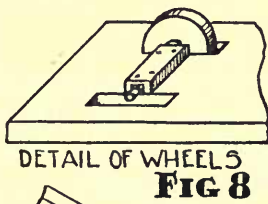
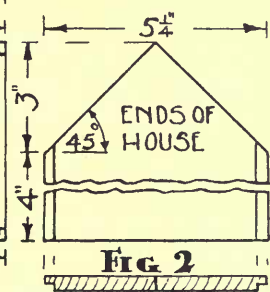
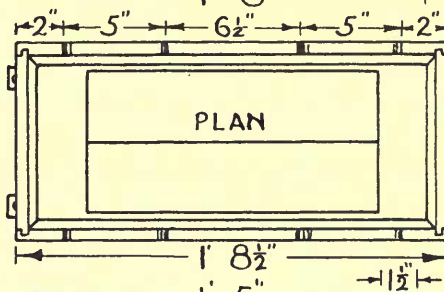
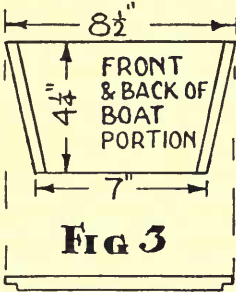
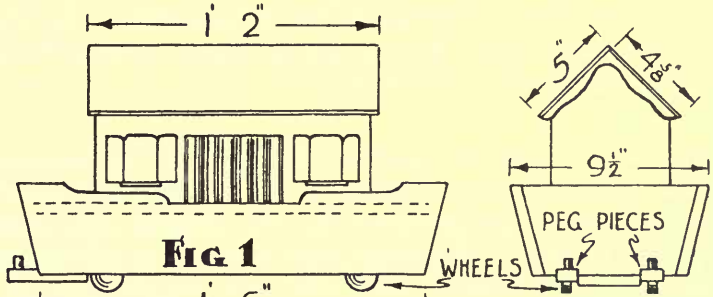
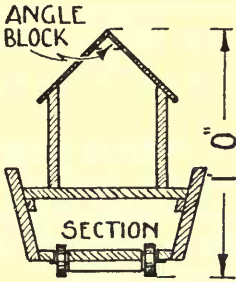
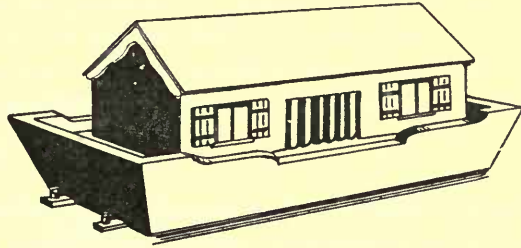

A N I M A L S

The five sketches are of wild animals to be mounted on wheeled bases and are designed to link up with, and be drawn behind, the ark on the previous page. A pair of each should be cut. Other animals, both wild and domestic, may be added if desired. When not in use the animals may be stored away in the ark.

CUTTING THE ANIMAL SHAPES.—The shapes should be cut from plywood about $\frac{3}{8}$ " thick. First cut ten pieces of plywood, two for each shape, a little larger than the given sizes. Square two adjacent sides, and with a try square and pencil set out the squares. With these as guides mark out the animals. Cut the tenons below each shape before the shape itself. Having cut the figures with a fretsaw and finished the edges with glasspaper, prepare the bases.

BASES.—One will be required for each figure. They are $5\frac{1}{4}$ " long, $2\frac{1}{2}$ " wide, and $\frac{3}{8}$ " thick. From the sketch mark out and cut the four wheel mortices, then mark out on one end the $\frac{3}{4}$ " \times $\frac{3}{4}$ " projection for the coupling peg. Make the vertical cuts before sawing the shoulders. Round-off the corners as in the sketch and in the centre of the projecting portion carefully bore a $\frac{1}{4}$ " hole and glue in a $\frac{5}{8}$ " length of dowel.

WHEELS.—The wheels are made from hardwood and are $1\frac{1}{2}$ " diameter and $\frac{1}{4}$ " thick. They are mounted in the mortices so as to prevent their being pulled off. Attach wheels to base by a 1" No. 6 screw through each, as in sketch.

COUPLING PIECES.—These are of $\frac{1}{4}$ " plywood $5\frac{1}{4}$ " long and $\frac{3}{4}$ " wide. Mark out along centre lines the two through mortices for the tenons on the animals. The dimensions for these must be taken from the individual animals. Cut the mortices. Through one end of each piece with its centre $\frac{1}{2}$ " from the end, bore a $\frac{3}{8}$ " hole. Round-off the other end as in sketch.

PAINTING.—Before assembling clean up and paint the various parts in suitable colours. For example, the bases, couplings and wheels may be blue, the zebra cream with black bands, the kangaroo brownish red, deeper in colour along the back, the polar bear creamy white, the camel yellowish brown and the elephant grey with white tusks.

ASSEMBLY.—Glue and pin the coupling pieces to the bases, allowing end with hole to project 1". Glue tenons and mortices and fix animals in bases, taking care they are upright.

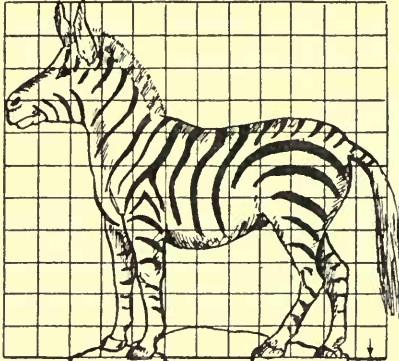

KANGAROO
SQUARES
 $\frac{1}{4} \times \frac{1}{4}$

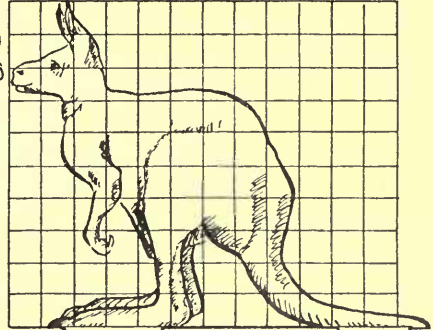

ZEBRA
SQUARES
 $\frac{1}{4} \times \frac{1}{4}$

$\frac{1}{2}$ " $\frac{3}{4}$ " $\frac{11}{16}$ " $\frac{3}{4}$ " $\frac{1}{4}$ "

$\frac{7}{16}$ " $\frac{3}{4}$ " $\frac{1}{8}$ " $\frac{9}{16}$ "

POLAR BEAR SQUARES $\frac{5}{16} \times \frac{5}{16}$

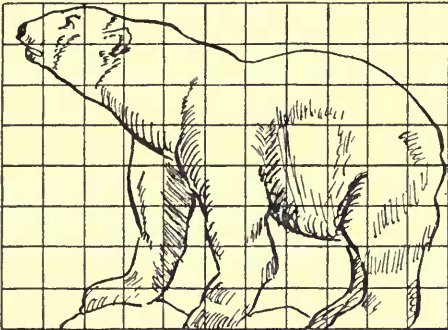

BASES, SHOWING WHEELS IN MORTICES
WITH SCREWS FOR AXLES AND $\frac{3}{8}$ "
MORTICES THROUGH COUPLING PIECES

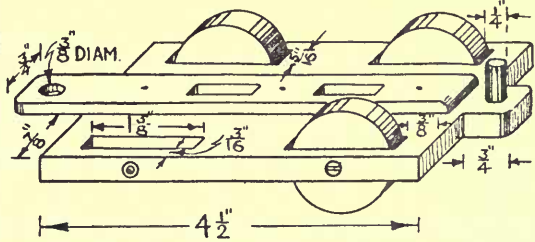

$\frac{13}{16}$ " $\frac{5}{4}$ " $\frac{13}{16}$ " $\frac{5}{4}$ "

$4 \frac{1}{2}$ "

CAMEL SQUARES $\frac{3}{8} \times \frac{3}{8}$

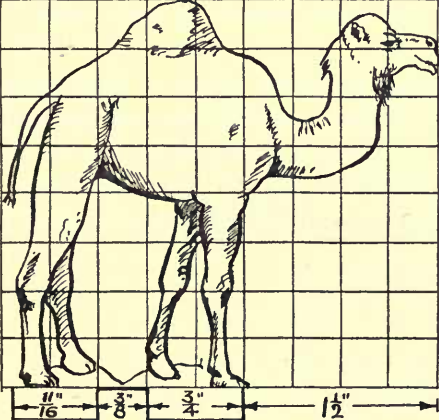

ELEPHANT SQUARES $\frac{3}{8} \times \frac{3}{8}$

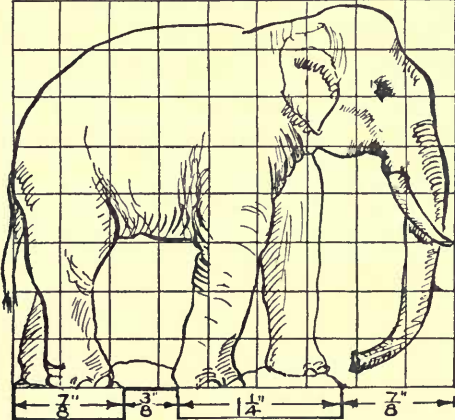

$\frac{11}{16}$ " $\frac{3}{8}$ " $\frac{3}{4}$ " $1 \frac{1}{2}$ "

$\frac{7}{8}$ " $\frac{3}{8}$ " $1 \frac{1}{4}$ " $\frac{7}{8}$ "

ENGINE

All engines are popular with children. The sturdiness, pleasing appearance and modern lines of this model make it particularly attractive. It is 2' 8" long, 11" wide, and 1' 0½" high.

CONSTRUCTION

UNDERCARRIAGE.—Prepare two side pieces 2' 7" × 2¼" × ¾". From Fig. 2 mark out and cut two grooves ¾" wide by ¼" deep. Cut bevel 1" × 1" on each bottom corner (Fig. 1). Prepare two end pieces 10" × 2¼" × ¾". Fit, glue and nail undercarriage together, keeping it square and flat.

BASEBOARD.—This is 2' 8" × 11" × 7⁄8". Both ends are square.

BOILER.—Cut two pieces 1' 4" × 5¼" × 1". Make a ¼" × ¼" tongue along on edge of each. Next prepare one piece 1' 4" × 8" × 2". Plough two grooves ¼" wide by ¼" deep on one side, as in Fig. 3. Fit and glue the three pieces together. Glue blocks along angle of each joint (Fig. 3). When the glue has set, shape the top to a curve, as in Fig. 3.

CAB.—Cut and shape two side pieces 9½" × 4½" × ¾", as in sketch, and a top piece 10" × 4½" × ¾". Dovetail pieces together (Figs. 1 and 4) with tails at top of side pieces. Clean inside faces and glue up square. Cut front of cab 9½" × 10" and glue and screw it to sides and top. Round-off corners, as indicated.

TENDER.—Prepare sides 9½" × 5" × ¾". Round front corners as sketch. Prepare back 10" × 5" × ¾". Dovetail pieces together, clean insides and glue together.

TANK PIECES.—Prepare two 7" × 5" × 5⁄8" and make square at both ends.

ASSEMBLY.—Clean up outsides of cab and tender. Screw boiler to base, then cab to boiler and base, and also tender to base. Now screw base to undercarriage and glue and nail tank pieces to boiler. Complete boiler by fitting a 3⁄8" capping piece over open end (Fig. 1) and by letting into top two short lengths of 1½" and 2" rod as funnel and valve (Fig. 1). Finally mount wheels on 3⁄8" or ½" mild-steel rod—see sketch—and paint in bright colours.

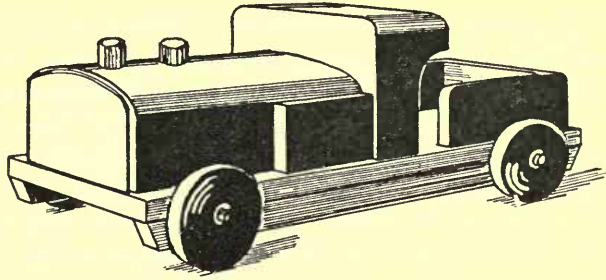

SECTION OF WHEEL

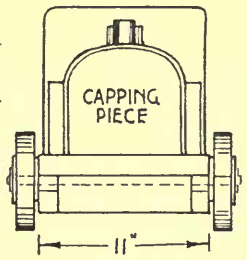
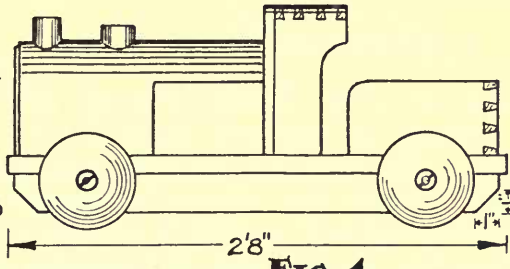
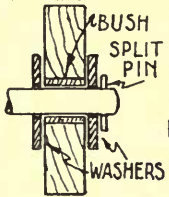

FIG 1

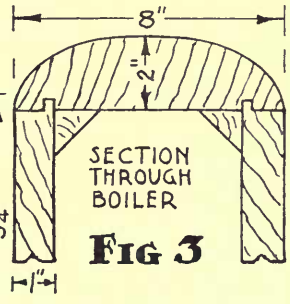
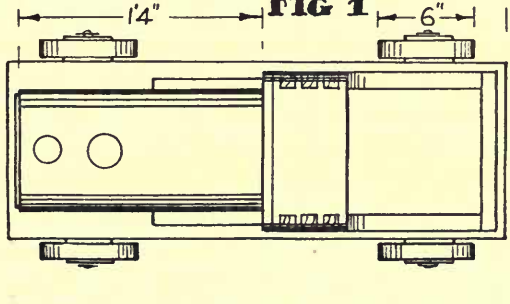
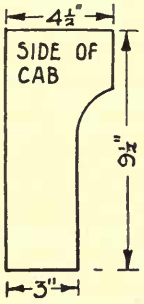

FIG 3

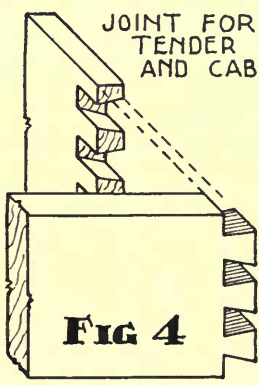
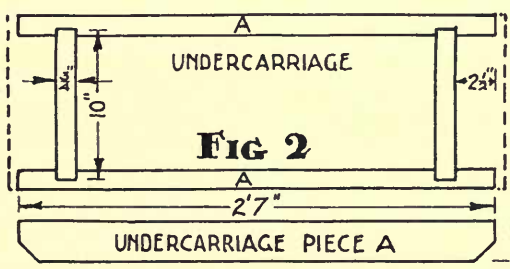
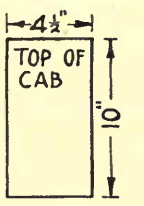
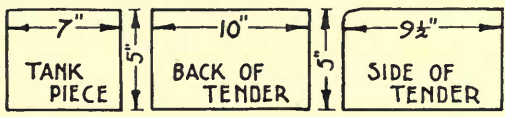
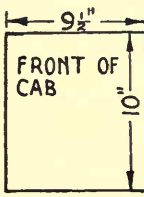

FIG 4



STREAM-LINED LOCOMOTIVE

This stream-lined locomotive, so modern and pleasing in appearance, is large enough to carry three or four small children at a time. It is 4' 0" long, 1' 0" high and 8½" wide, yet despite its large size it is not particularly difficult to construct. It is made in five deal sections, A, B, C, D and a bogey. When the construction is complete the engine should be painted in bright red, green or blue, with the bogey and sides of section D in black. The wheels should be black or the colour of the body. If red or green is used for the body, a heavy black line, following the line of the chamfer as in Fig. 1, adds greatly to the stream-line appearance. If blue is used for the body, aluminium paint is most suitable for this line. The chamfer and the vertical portion of the smoke stack also may be painted in similar colour to the line.

CONSTRUCTION

SECTION A.—This consists of a 1½" framing (Fig. 2) with a cover board 3' 10" × 8½" × 1". For the framing, cut two side pieces 2' 11" × 1½" × 1" and at both ends cut a ½" × ½" tongue. The front is a block 7½" × 6" × 1½" and the back another block 8½" × 6½" × 1½". Cut the four grooves for tongues and fit and glue the framing together. Shape the cover board, as in Fig. 2, and glue and nail it with oval brads to the framing. Now from Figs. 2 and 7 (Page 101) complete the shaping of the boiler and cab along the whole length of the section, leaving a 1½" wide flat on the top for a smoke stack. The outer curve of Fig. 7 shows the shape of the cab. For this shaping use smoothing plane, flat spokeshave and paring chisel, and reduce the section to approximate shape only; leave the final shaping until after all the boiler sections are assembled.

SECTION B.—The construction of this section is similar to that of the framing in Section A. The side pieces are 3' 1½" × 2½" × 1" with ½" × ½" tongues at the ends. The front is 7½" × 6½" × 2½" and the back 8½" × 4½" × 2½". Set out the curves from Figs. 3 and 6 (Page 101) and shape as in Section A. The "V" notch is cut in the front block to allow the nut of the pivot bolt to be screwed down.

(Continued on Page 100)

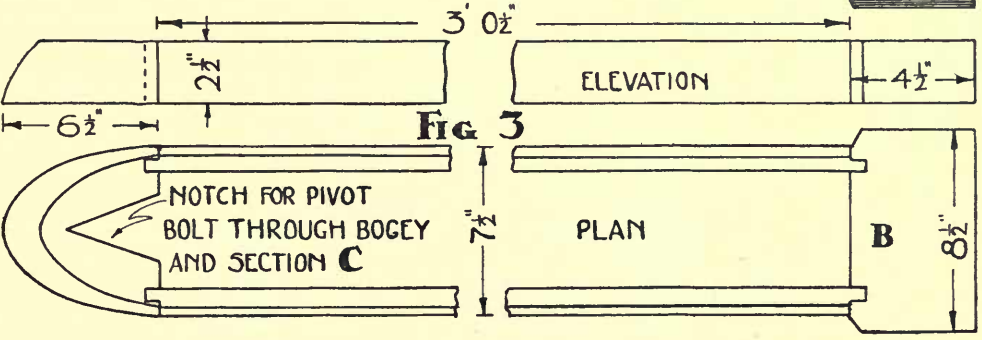
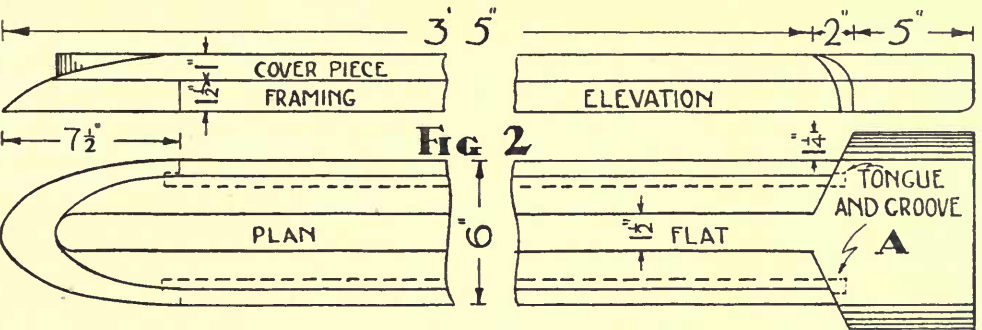
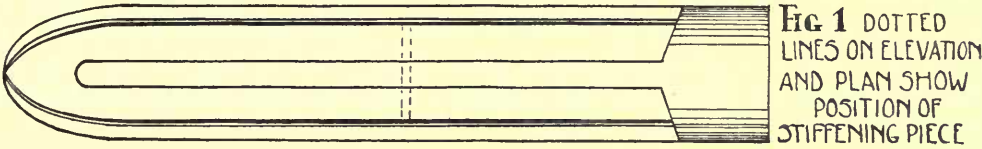
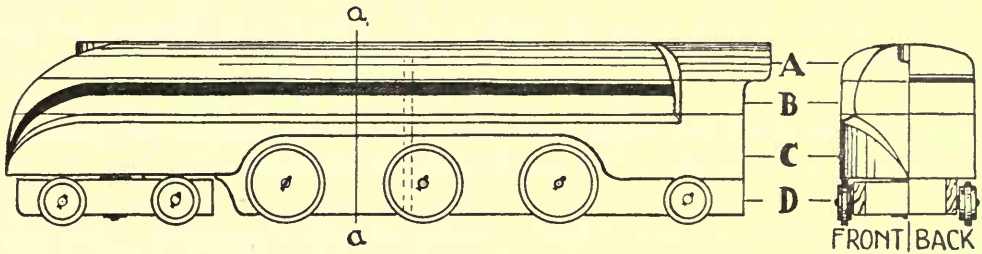
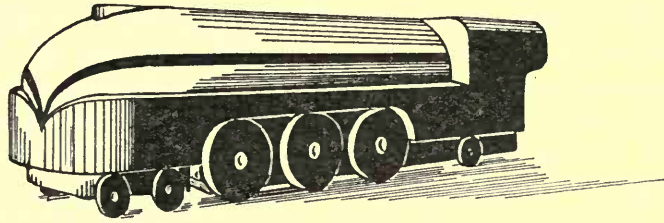

STREAM-LINED LOCOMOTIVE—*continued*

SECTION C.—The side pieces of this section are 3' 1" long, 4" wide and 1" thick, with a cut-away portion in the middle 1' 11" \times 2 $\frac{1}{4}$ " (Fig. 4). The front, which may be in one block or built up, is 8 $\frac{1}{2}$ " \times 8" \times 4", and the back 8 $\frac{1}{2}$ " \times 4" \times 4". Tongue and groove together the front, sides and back, shape the curves as in Fig. 4, and make a $\frac{3}{4}$ " \times $\frac{1}{2}$ " chamfer on the top edge. Let this end in a mason's mitre at the cab and run out in front as Fig. 4

SECTION D.—Prepare two side pieces 2' 9 $\frac{1}{2}$ " \times 5 $\frac{1}{4}$ " \times $\frac{3}{4}$ " (Fig. 5), a front piece 5 $\frac{3}{4}$ " \times 3" \times $\frac{3}{4}$ " and a back piece 5 $\frac{3}{4}$ " \times 2 $\frac{1}{4}$ " \times $\frac{3}{4}$ ". Cut $\frac{3}{8}$ " \times $\frac{3}{8}$ " tongues and grooves and glue together. See that the frame is quite square.

BOGEY.—Construct the bogey from 2" \times 1" deal with tongue and groove joints. Bore a $\frac{3}{8}$ " hole in the middle of the centre piece for the pivot bolt.

ASSEMBLY.—Fit A, B and C "dry," planing off level if necessary. First glue and nail together Sections B and C, using oval nails, and then fix A to them. Punch in the nails and complete the shaping of the whole boiler. Glue and screw Section D in place. To give additional strength a supporting piece (Figs. 1 and 7) may be cut from $\frac{1}{2}$ " deal and fixed inside when assembling the sections. Bore the hole through the front block of Section C and bolt the bogey in place.

WHEELS.—The large wheels are 5" and the small ones 2 $\frac{3}{4}$ " in diameter. Each is made of a $\frac{3}{8}$ " square-section rubber ring, supported by a $\frac{3}{8}$ " thick disc, with a $\frac{1}{4}$ " plywood disc of $\frac{1}{2}$ " larger diameter glued and screwed on each side. The wheels are bushed, have a washer on each side and are held on $\frac{3}{8}$ " axles by split pins. Bore holes for the axles in the bogey and at the rear of Section D, then bore the others for the larger wheels. Insert the axles and attach the wheels as shown in sketch.

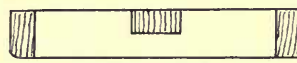
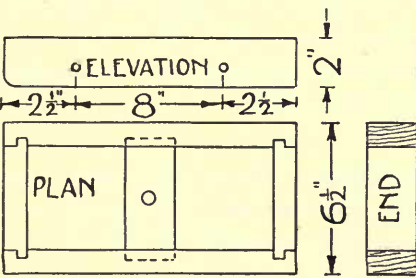
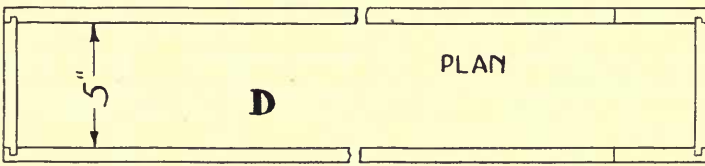
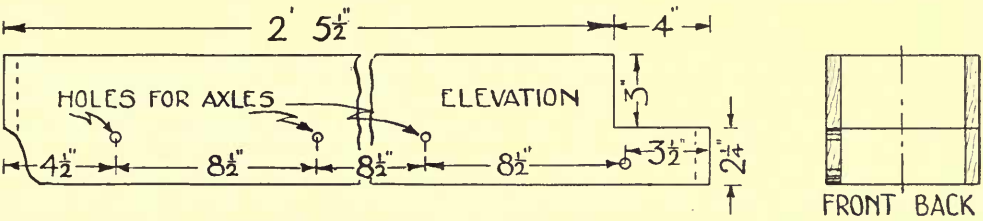
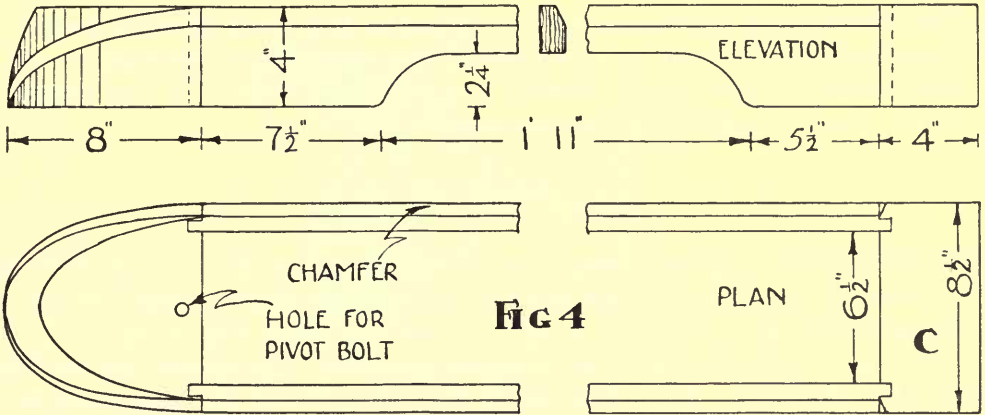

SECTION VIEWS OF BOGEY

Fig 6

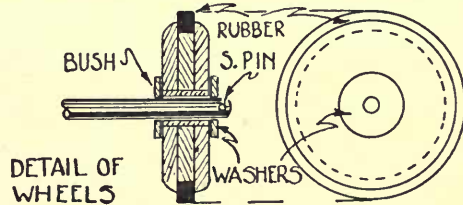
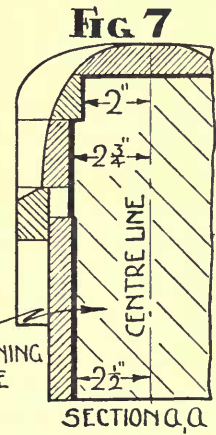
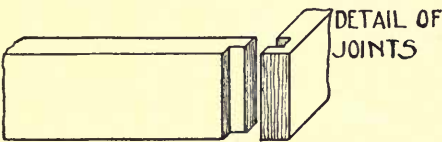

W H E E L B A R R O W

This wheelbarrow has been carefully planned so that when lifted its weight is so completely thrown on to the wheel that quite a small child can use it even when it is loaded. Its over-all length is 2' 4", width 1' 3" and height 1' 2". Deal is suggested for its construction.

CONSTRUCTION

UNDERFRAMING.—Prepare two side or handle pieces 2' 1" \times 1 $\frac{1}{2}$ " \times 1" as in Fig. 2. Mark out and cut in each the two through mortices shown. These are 1 $\frac{1}{2}$ " \times 1 $\frac{1}{2}$ ". Now prepare two bars, one 1' 0 $\frac{1}{2}$ " \times 1 $\frac{1}{2}$ " \times 1" and the other 10 $\frac{1}{2}$ " \times 1 $\frac{1}{2}$ " \times 1". From Fig. 3 mark out barefaced tenons with splayed shoulders. Cut tenons and fit "dry." Chamfer ends of tenons. Shape two pieces 4" \times 1" \times 1" and glue and screw to side pieces as in Fig. 2. From a piece of $\frac{1}{8}$ " mild steel make two gudgeon plates as in sketch and screw in position (Fig. 2).

WHEEL.—From a board 3" wide and 1" thick mark out, cut and finish four felloes. Cut butt joints. In both ends of each felloe bore a $\frac{3}{8}$ " hole $\frac{3}{4}$ " deep. In one end of each glue a 1 $\frac{1}{2}$ " length of $\frac{3}{8}$ " dowel rod. In the centre of the inside curve of each felloe bore a $\frac{3}{8}$ " hole $\frac{1}{2}$ " deep to receive the dowel in the end of a spoke (see sketch). Cut three spokes from $\frac{3}{4}$ " dowel rod, two 2 $\frac{7}{8}$ " long and the other 7". The latter goes through the axle from felloe to felloe. Bore ends of spokes and insert $\frac{3}{8}$ " dowels with $\frac{1}{2}$ " projecting. From material of 1 $\frac{1}{4}$ " \times 1 $\frac{1}{4}$ " section shape the axle illustrated. Bore a $\frac{3}{4}$ " hole through in one direction and a $\frac{3}{8}$ " hole in the other (see "section"). Screw a 2" No. 16 screw into each end of the axle and cut off the heads. Fit wheel together "dry," measure circumference with string and bend tyre from 1" \times $\frac{1}{8}$ " mild steel. Drill screw holes in it, then glue up wheel and fix tyre in place.

BODY.—Shape two sides from material $\frac{5}{8}$ " thick as Fig. 6. Cut grooves for back, or "headboard" (Fig. 4). From $\frac{1}{2}$ " board prepare the bottom (Fig. 5). The two legs are 1' 1" \times 1 $\frac{1}{2}$ " \times 1 $\frac{1}{4}$ "; shape as in Fig. 1. Finally cut two side bars, or "front pillars," 11" \times 1 $\frac{1}{4}$ " \times $\frac{1}{2}$ ". Chamfer edges of these and of legs (Fig. 1).

ASSEMBLY.—Glue up the framing with wheel in position. Screw down the bottom. Glue and nail sides to back and screw these to bottom and framing. Screw legs to sides and framing, then bore $\frac{1}{4}$ " holes for tie bar, which may be screwed or riveted. Screw on side bars and finish with varnish or colour.

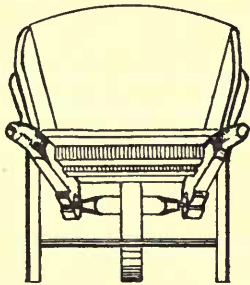
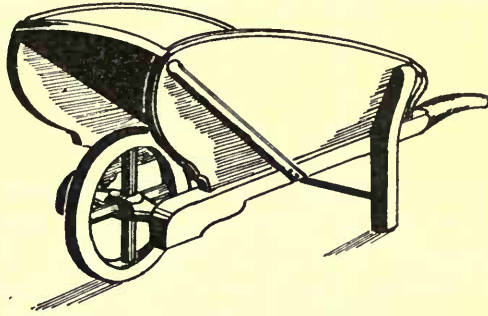

9"

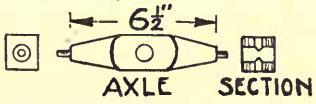
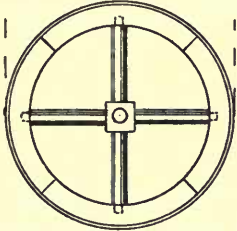

AXLE SECTION



FELLOE

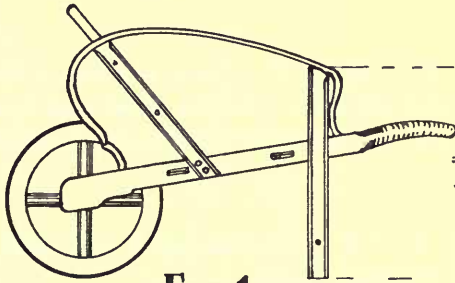

FIG 1

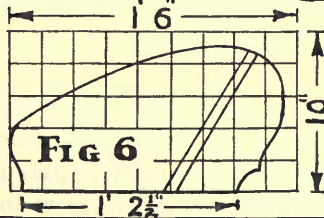
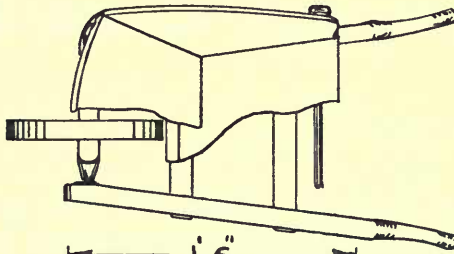
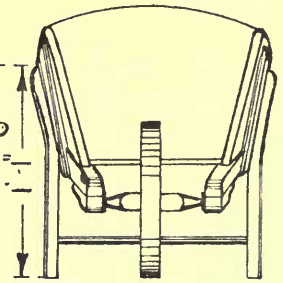
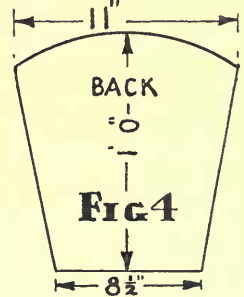
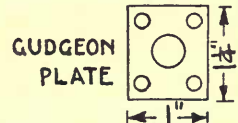

FIG 6



BACK

FIG 4



GUDGEON PLATE

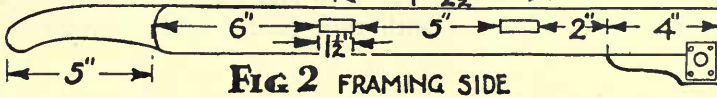
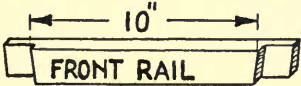
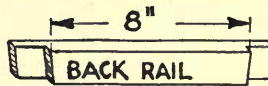

FIG 2 FRAMING SIDE



FRONT RAIL

FIG 3



BACK RAIL

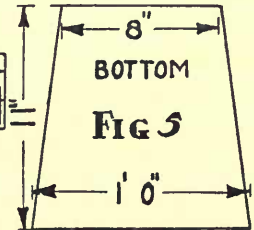

BOTTOM

FIG 5

SMALL SWING

The small swing illustrated opposite is ideal for a very young child, or, if the height is increased by 1' 6", it becomes a useful swing for children up to five years of age.

CONSTRUCTION

BASE.—Prepare two sides 3' 0" × 2" × 1" and at both ends of each mark out and cut bridle joints (Figs. 2 and 6). In the centre mark out and cut a through mortice $2\frac{1}{2}" \times \frac{1}{4}"$. Cut also the groove 1" wide and $\frac{1}{4}"$ deep as Fig. 2. Finally cut the two joints shown for struts. When cutting these leave a little for a final fitting with the strut itself. Prepare two end pieces 1' 8" × 2" × 1" and cut tenons on the ends (Fig. 6). Fit and glue the base together square. Cut a cross piece 1' $6\frac{1}{2}" \times 2" \times 1"$ and fix in the grooves.

POSTS.—These are 2' 6" × $2\frac{1}{2}" \times 1"$. Mark and cut a tenon on one end of each (Fig. 3) and fit the tenon into the base. At the other end of each post cut bridle joints (Fig. 3). Now mark out and cut joints for struts and, as in base, leave a little for final fitting.

STRUTS.—Cut four, 1' 6" × 2" × 1", and bevel the ends as shown in Fig. 5. Fit struts to base and posts. Number joints.

TOP RAIL.—Make this 2' 0" × 2" × 1". Mark out, and from Fig. 4 cut and fit rail to posts.

SLATS.—Cut five 2' 11" × 3" × $\frac{3}{8}"$.

ASSEMBLY.—First clean up all parts. Glue and wedge posts into base. Glue and screw top rail in position, then glue and screw struts to base and posts, using one screw in each joint. Fasten slats to base, as Fig. 1.

SEAT.—This is 11" × 11" × $\frac{3}{4}"$. Four small safety bars 11" × $1\frac{1}{2}" \times \frac{3}{8}"$ should also be prepared, rounded off on all edges, and have a hole bored 1" from each end. Spacing pieces, to fit between these and the seat, may be prepared by boring through sections of cylindrical material, e.g., brush handle. Fit together as in Fig. 1 and hang on two stout screw-eyes fixed in top rail. Bind the ropes with thin cord immediately below the screw-eye.

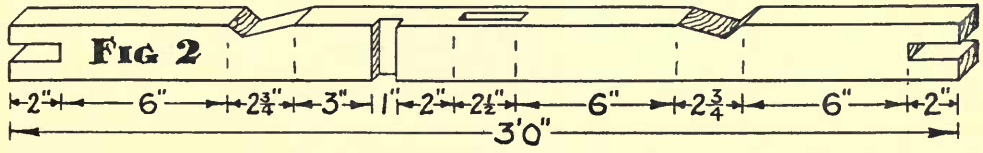
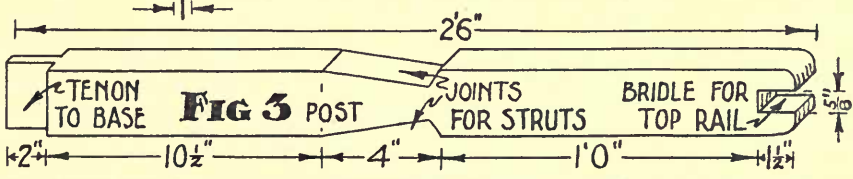
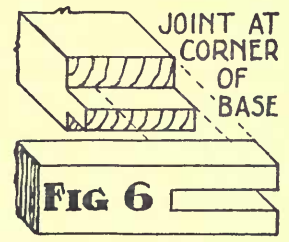
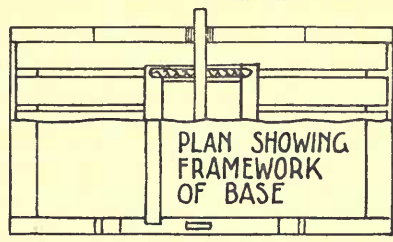
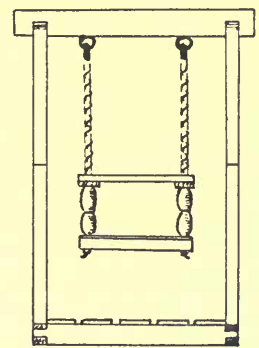
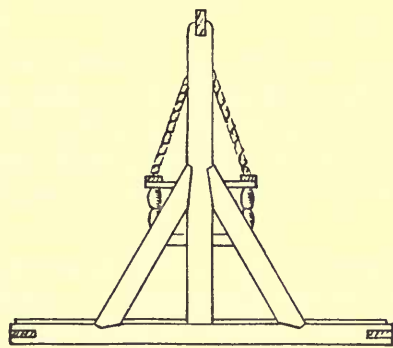
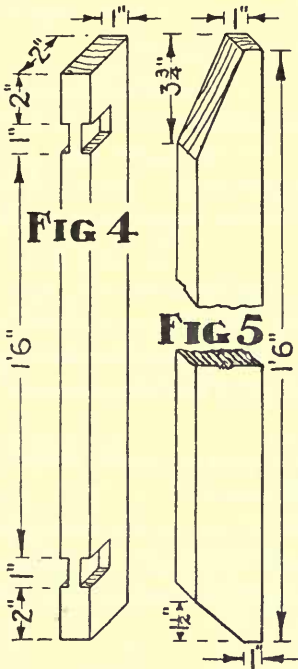
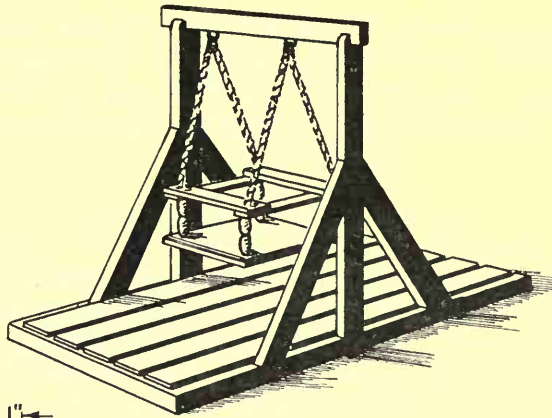

METAL SWING

This attractive indoor swing has been planned for a small child of two to four years but, if desired, it may easily be enlarged to take bigger children. The swing is made up of two tubular frames, rectangular in shape, mounted on a wooden base. The seat swings on two metal bushes so as to eliminate wear on the ropes.

CONSTRUCTION

METAL FRAMING.—Bend a piece of $\frac{5}{8}$ " tubing into a rectangle 4' 0" \times 2' 0" (Fig. 3) with the joint 6" from one side. In the long end insert a metal dowel and drill a $\frac{1}{8}$ " hole through both tube and dowel. After countersinking both ends of hole, drive in and "spread" rivet, then file ends smooth (Fig. 4). Close the frame and, 5" from the side, drill a second $\frac{1}{8}$ " hole through tube and dowel for a split pin (Fig. 2). Drill a corresponding hole 5" from the other side (Fig. 1).

By means of a board 5" wide and two "G" cramps hold one end of the frame on a bench and lift up the free end 8 $\frac{1}{2}$ " from the bench top (Fig. 3). Now with a piece of the same tubing 9' 8" long bend an open-ended frame (Fig. 1). Fix the open ends of this to the bench top and make a similar bend on it 3" from the open ends. Bore $\frac{3}{16}$ " holes through both frames and, with two $\frac{3}{16}$ " bolts or rivets, fasten frames together as in Fig. 1.

BUSHES AND SPACING BAR.—From a piece of tubing of $\frac{3}{4}$ " internal diameter cut two pieces $\frac{3}{4}$ " long as bushes and one 1' 0 $\frac{1}{8}$ " long as a spacing bar. Open unfixed joint of frame and slide on, in this order, a washer, $\frac{3}{4}$ " bush, washer, spacing bar, washer, bush, washer. Finally close the frame and slip in both split pins (Figs. 1 and 2).

SEAT (Fig. 5).—This is 1' 1" \times 10" \times 1" with a $\frac{3}{8}$ " hole bored in each corner and with all corners and edges rounded off. Cut four seat rails, two 1' 1" \times 1 $\frac{1}{4}$ " \times $\frac{1}{2}$ " and two 10" \times 1 $\frac{1}{2}$ " \times $\frac{1}{2}$ ". Cut two holes in each to register with those of the seat. From a piece of tubing cut four distance pieces 7" long. Cut two 6' 0" lengths of good sash cord and mount the swing (Figs. 1 and 5). Tie the cords together immediately below the bushes. A single knot only is required under the seat.

BASE (Figs. 1 and 6).—Prepare two pieces of deal 3' 6" \times 2" \times 2", two pieces 2' 0" \times 2" \times 2" and two pieces 1' 8" \times 2" \times 2" (Fig. 6). Mark out, cut and fit joints "dry." Along top sides of middle pieces plough $\frac{5}{8}$ " \times $\frac{5}{8}$ " grooves. Glue up the frame, keeping it quite square. Prepare four slats 3' 5" \times 4 $\frac{3}{8}$ " \times $\frac{1}{2}$ " (Fig. 1).

ASSEMBLY.—Stand the bases of the rectangular tubing in the grooves of the base. Screw down the slats with a $\frac{3}{8}$ " space between each.

FINISH by painting in two bright colours.

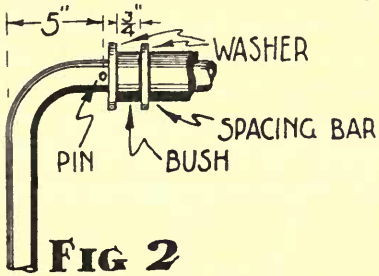
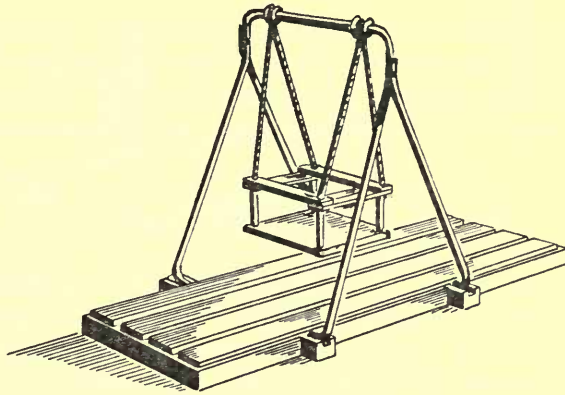

FIG 2



FIG 4

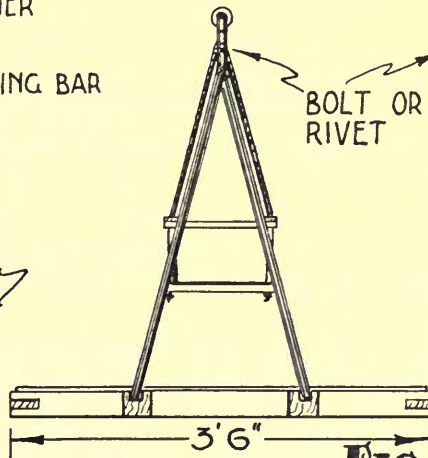

FIG 1

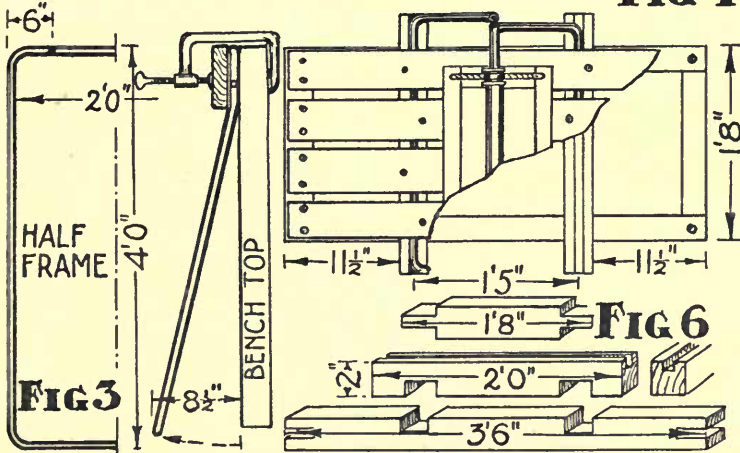
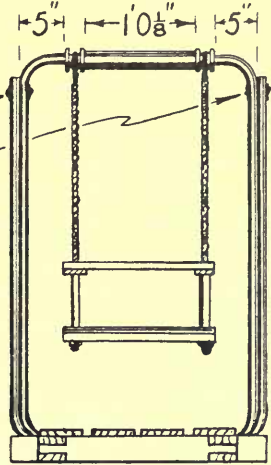

FIG 3

FIG 6

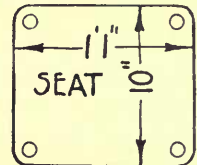
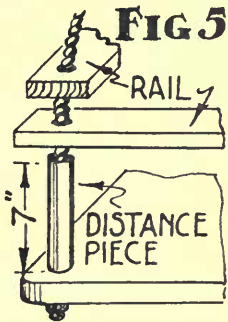

FIG 5



SEE - SAW

This see-saw is essentially one for very young children ; grips are provided to enable them to hold on securely, blocks under the seat guard against their rising too high, bumping violently, or trapping their feet. It is only necessary to lift off the seat portion to enable the see-saw to be stowed away in a small space.

CONSTRUCTION

BASE.—Prepare two side pieces $1' 8" \times 2" \times 2"$ and two cross pieces $1' 4" \times 2" \times 2"$. Set out and cut the four cross halving joints (Figs. 1 and 2). Fit them together "dry" and number them. Cut $\frac{1}{2}" \times \frac{1}{2}"$ bevels on the ends of each piece (Fig. 2). Bore two $\frac{5}{8}"$ holes through the side pieces $4\frac{7}{8}"$ on either side of the centre (Figs. 1 and 2). Clean up, then glue and screw the framing together, carefully checking for squareness. Bend two pieces of $\frac{5}{8}"$ stout metal tubing $2' 0"$ long into the shape shown in Figs. 1 and 3. These are the supports. Through the middle of the top (Fig. 3) bore a $\frac{3}{8}"$ hole. Cut a $9"$ piece of similar tubing as a rocking bar and drill two $\frac{3}{8}"$ holes as in Fig. 4. Clean up the base and insert the supports. Drill screw holes as in Fig. 2 and put two $1\frac{1}{2}"$ No. 8 screws in each support to hold it securely. Complete the base by bolting down the rocking bar with two $\frac{3}{8}"$ bolts.

HEADS.—From a board $1' 6" \times 4" \times 2"$ cut two heads. On the bottom ends cut tenons (Fig. 5). Through each head bore a $\frac{3}{4}"$ hole for an $8"$ length of $\frac{3}{4}"$ dowel rod.

SEE-SAW.—This is a board $7' 0" \times 6" \times \frac{3}{4}"$. Mark out and cut the mortices for the heads, bore holes for screws and round-off the edges of the board. From Fig. 1 shape two "shock-absorber" blocks $4" \times 3" \times 1\frac{1}{4}"$. Fasten a spiral or flat spring, or a thick piece of rubber, to the bottom of each block. Screw the blocks to the board (Fig. 1). Make two clips (Fig. 3) from $\frac{3}{4}" \times \frac{1}{8}"$ mild steel and screw them under the middle of the board. Glue the rods in the holes in the heads, glue and screw the heads to the board, and the see-saw is ready for painting.

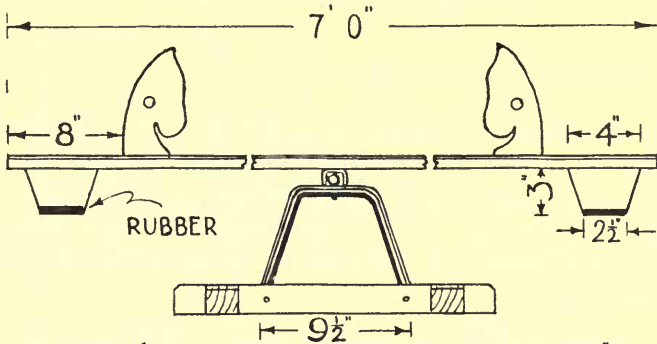
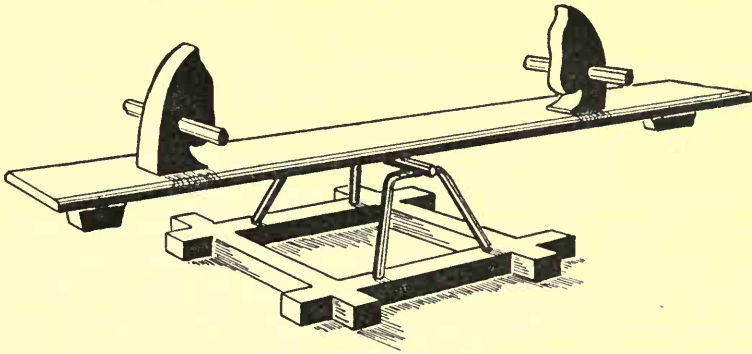

FIG 1

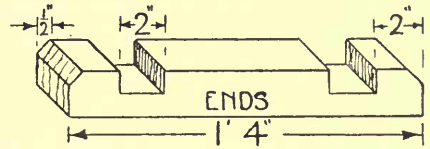
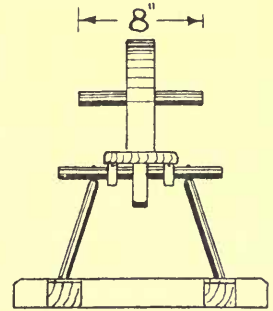

FIG 2

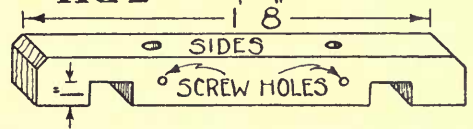
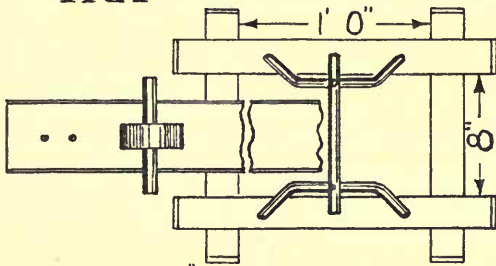

FIG 3

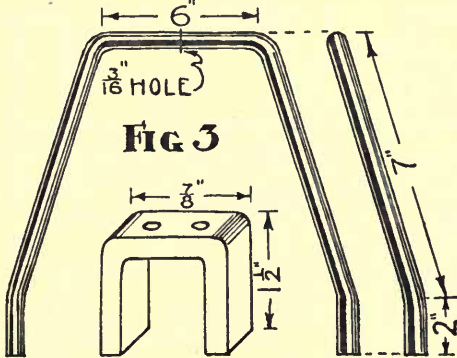

FIG 4

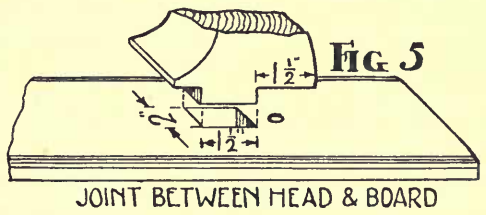

FIG 5

WAREHOUSE TROLLEY

The construction of this trolley involves a small amount of simple sawing, drilling and bending of metal tubing. The handles are formed from $\frac{5}{8}$ " conduit or similar tubing, screwed against the inner side of the base framing (Fig. 2). There are three axles of equal length and four wooden wheels (Fig. 1 plan) which, if possible, should be provided with metal bushes. The front and rear wheels are mounted centrally on the axles and held there by a split pin and washer on either side (Fig. 3), while the two middle wheels (Fig. 4) are at the ends of the centre axle. These wheels are about $\frac{1}{2}$ " larger in diameter than the front and rear wheels, to facilitate turning of the trolley. An alternative method of holding the wheels in place is by the use of spacing bars of larger diameter tube, as in the swing on Page 106, instead of split pins.

CONSTRUCTION

UNDERFRAMING.—Prepare two sides to a finished size of $1' 9" \times 3" \times \frac{7}{8}"$ and two ends $1' 1" \times 3" \times \frac{7}{8}"$. Set out and cut "tails" for common dovetails on sides and from these set out "sockets" on end pieces. Cut sockets and fit frame "dry." In both long sides set out and bore holes $\frac{1}{2}"$ deep for the axles. The distance of these from the bottom edge will depend upon the diameter of the wheels. In both the end pieces bore two $\frac{5}{8}"$ holes for the handles (Fig. 2).

Cut axles to a length of $12\frac{1}{4}"$ so that $\frac{1}{2}"$ rests in each side piece. Drill holes for split pins and mount wheels. Glue joints, insert axles and wheels, and put frame together, carefully checking for squareness.

HANDLES.—From two pieces of $\frac{5}{8}"$ tubing $5' 6"$ long bend handles to given shape. Drill four $\frac{3}{16}"$ screw holes for bars for handle and six $\frac{3}{16}"$ holes, three on either side, for fixing handles to framing. Alternative suggestions for bars across the handles are given in Figs. 1, 5 and 6. Prepare four pieces according to style selected.

SLATS.—Prepare eight pieces of deal $1' 2" \times 2\frac{1}{4}" \times \frac{3}{8}"$ for slats of base. Bore and countersink a $\frac{3}{16}"$ screw hole $\frac{7}{8}"$ from the ends of each slat.

ASSEMBLY.—If bars as Fig. 6 are used, slide and screw them into position, then insert tubing into base and screw handles to framing. If bars as Fig. 5 are used, they may be screwed in place after handles are fixed. Paint top edge of base and edges of slats, then screw down slats and finish the painting.

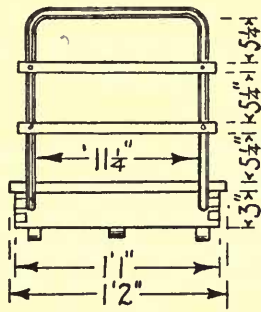
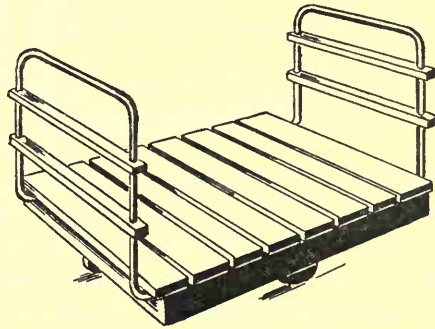

FIG 3
SECTION OF FRONT
OR REAR WHEEL

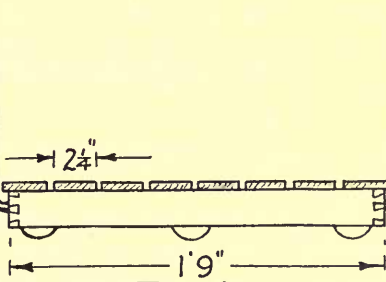
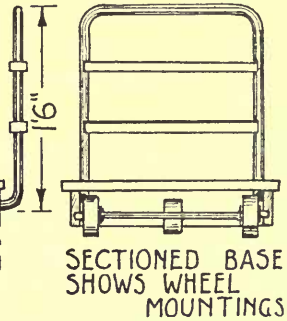
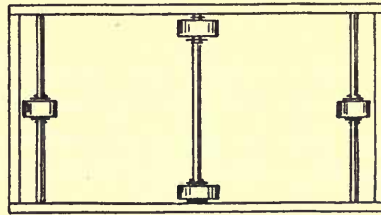

FIG 1



SECTIONED BASE
SHOWS WHEEL
MOUNTINGS



PLAN WITH SLATS AND HANDLES
REMOVED TO SHOW WHEEL
MOUNTINGS

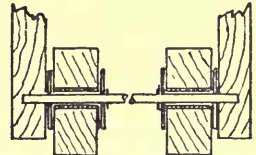

FIG 4

SECTION SHOWING
CENTRE WHEELS

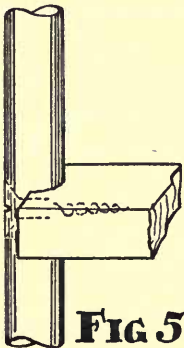

FIG 5

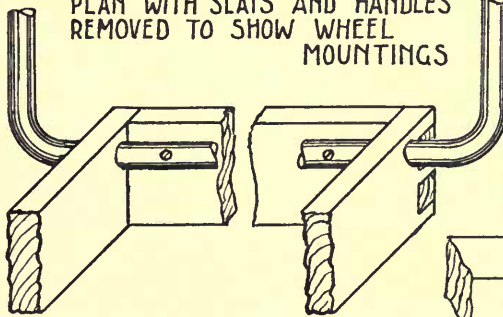

FIG 2
HANDLES SCREWED
TO SIDES OF BASE

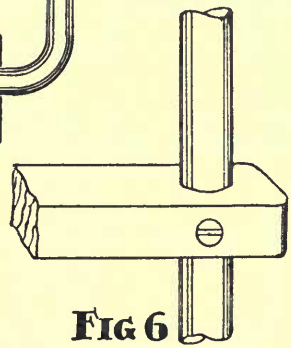

FIG 6

LONG SWING

In a nursery a swing which will accommodate four or five children at a time is particularly useful. Although rather long (7' 0") when in use, this swing can be dismantled very quickly by the removal of two wing nuts, and stored away in a small space.

CONSTRUCTION

TUBULAR FRAMES.—From two 12' 0" lengths of stout metal tubing of $\frac{5}{8}$ " or $\frac{3}{4}$ " diameter, bend two rectangles 4' 0" \times 2' 0", then with a hacksaw shorten the arms of the open ends to 7 $\frac{1}{2}$ " each (Fig. 5). To hold frames closed cut two 7" lengths of slightly larger tube that will fit easily over the framing. Insert open ends of frames into the 7" tube, press together until ends touch, and with 7" tube in centre drill two $\frac{3}{16}$ " holes through both tubes for $\frac{3}{16}$ " bolts. The two frames should now be 4' 0" long and 2' 0" at the bottom, tapering to 1' 3" at the top (Fig. 5). Complete frames by bending across middle at an angle of 60° (Fig. 1), as described with metal swing (Page 106).

ROCKER ARMS.—Prepare pieces of hardwood 1' 3" \times 1 $\frac{3}{4}$ " \times 1" with rounded ends as Fig. 3. Bore a hole $1\frac{1}{2}$ " from each end to take a 1" length of the larger tube as a bush. A screw may be put through wood and bush, and filed level inside the bush to prevent it moving in the wood (Fig. 3). Cut two pieces of the smaller tube 10" long for the bottom bar of the rockers. A $\frac{1}{8}$ " hole should be drilled $\frac{1}{2}$ " from each end for a split pin.

ASSEMBLY OF ROCKER ARMS.—Open the frames. Slide on each side a washer followed by a wooden arm, then close and fix the ends of the frame inside the 7" tube. Hold washers and arms against tube and drill a $\frac{1}{8}$ " hole at each end for a split pin. Slip in the bottom bar, add a washer outside each end and insert pins (Figs. 1 and 3).

BASE.—This is constructed from a piece 7' 0" \times 2" \times 2" and two cross pieces 2' 4" \times 2" \times 2". These should be cross-halved 9" from ends of long piece, as in Figs. 2 and 6, and bored for a $\frac{3}{8}$ " bolt. Cut notches 2" from ends of each piece to fit over tubes. Permanently fix frames to cross pieces by bolts or rivets (Fig. 2).

SEAT.—This is a board 5' 6" \times 7" \times $\frac{7}{8}$ " with top edges slightly rounded. Screw two metal clips (Fig. 4) $3\frac{1}{2}$ " from each end. These drop into position over bars of rocker arms.

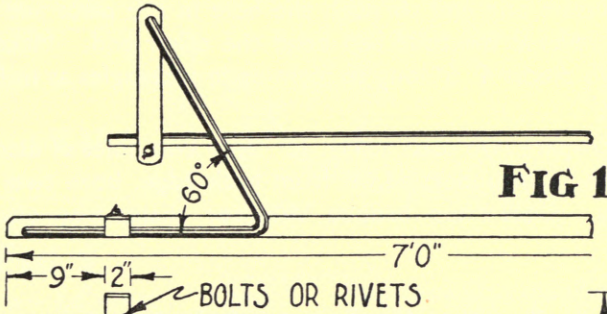
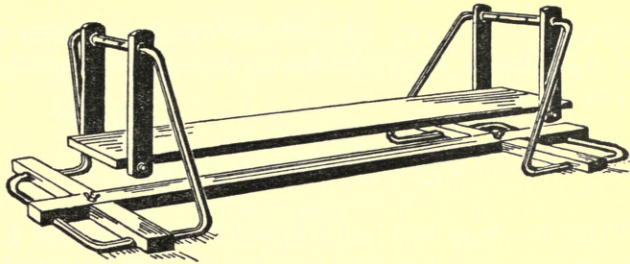

FIG 1

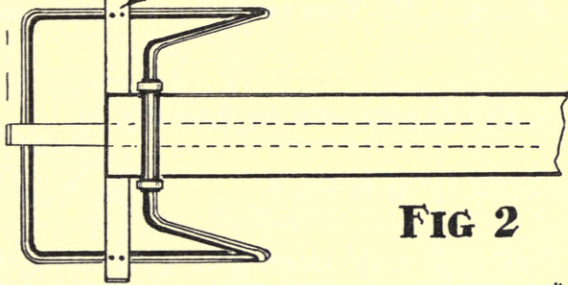

FIG 2

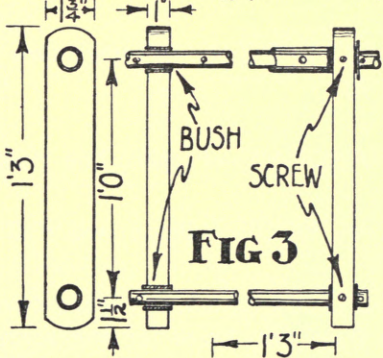
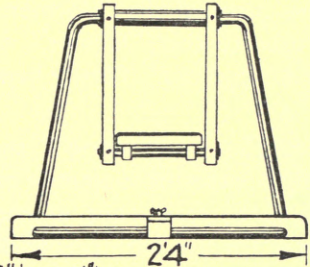

FIG 3

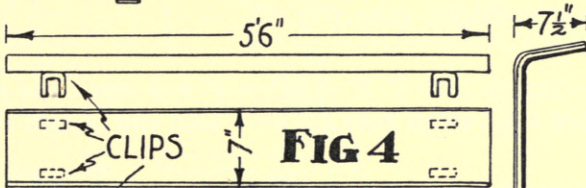

FIG 4

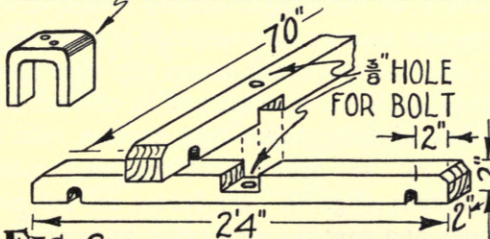

FIG 6

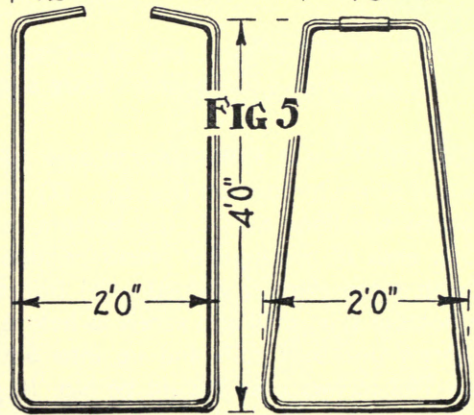

FIG 5

TUBULAR ROCKER

For two children this is a very popular toy which combines the thrill and movement of the see-saw with valuable stretching and pulling exercise for arms, chest and shoulders.

CONSTRUCTION

TUBULAR PORTION.—From any stout board 3' 2" \times 10" cut a "former" to the curve of Fig. 3. On one end screw a stout metal plate with a hole of the same diameter as the tube to be used for rockers. Cut off a piece of $\frac{5}{8}$ " or $\frac{3}{4}$ " stout metal tube as long as the curve of the "former." Insert one end through the hole in the plate and bend the tube to the "former," then reverse the tube and bend the other end. Make two of these rockers. Finally bend two pieces 4' 5" long to form open rectangles as in Fig. 2.

SEATS.—From wood 1" thick prepare two seats as Fig. 1. Bore two holes of diameter equal to exterior diameter of tube. On underside, 4" from back edge, bore two holes $\frac{1}{2}$ " deep to take ends of rockers. Seats from broken Windsor chairs may often be adapted for use with this rocker.

SEAT BATTENS.—Prepare two 1' 4" \times 2" \times 1". Bore two holes in each for rockers (Fig. 1).

HANDRAIL.—Prepare one 1' $4\frac{1}{2}$ " \times 2" \times 1" with holes for tube (Fig. 5).

TAIL PIECES.—Shape two 1' 0" \times $2\frac{1}{4}$ " \times $1\frac{1}{2}$ " as in Fig. 4.

BOTTOM RAILS.—Prepare two 1' $4\frac{1}{2}$ " \times 3" \times $1\frac{1}{2}$ " tapering to $\frac{3}{4}$ " as in Fig. 5. In each bore two holes for the rectangular-shaped tube (Fig. 9).

FLOOR SLATS (Figs. 2 and 5).—Prepare four 2' 5" \times $2\frac{1}{2}$ " \times $\frac{1}{2}$ " and one cross piece 1' 2" \times 2" \times $\frac{3}{4}$ " for a footboard. Bore a $\frac{3}{16}$ " screw hole $2\frac{1}{2}$ " from each end of each slat.

ASSEMBLY.—(1) Slide handrail over to centre of rectangular-shaped pieces, drill $\frac{3}{16}$ " holes and screw in position (Fig. 6). (2) Screw seat battens on underside of seats (Fig. 7). (3) Screw the floor slats to the bottom rails and the footboard across the slats (Fig. 2). (4) Slip ends of rectangular pieces of tube through holes in seats and at correct height screw in place (Figs. 2 and 8). (5) Insert ends of these tubes into bottom rails flush with bottom side, drill and screw as before (Fig. 9). (6) Spring both rockers in position and screw into seat rails and up into bottom rails (Fig. 9). (7) Screw on tail pieces. *Note.*—The screws used should be No. 10 gauge and pass through tubes with at least $\frac{3}{4}$ " into the wood on the other side.

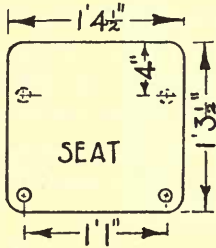
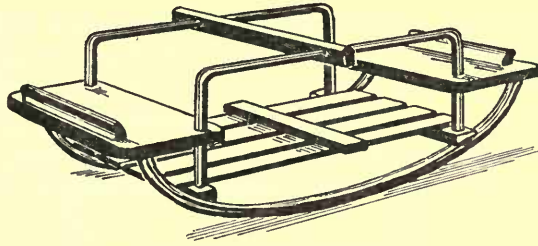

FIG 1

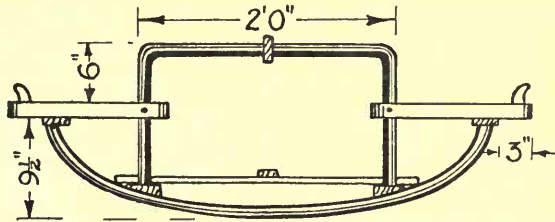

FIG 2

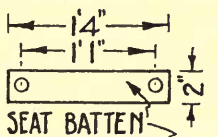
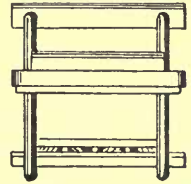

FIG 4

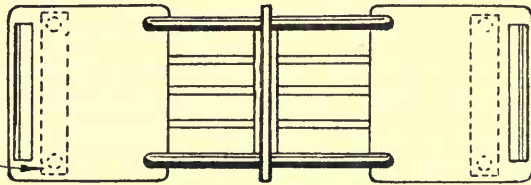

FIG 5

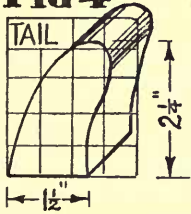

FIG 7

POSITION OF SEAT BATTEN AND TAIL PIECE

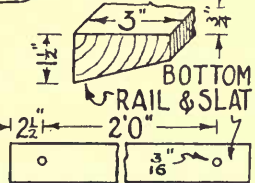
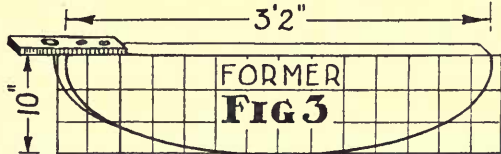

FIG 9

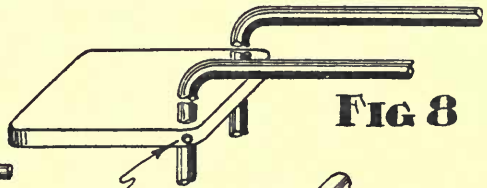

FIG 8

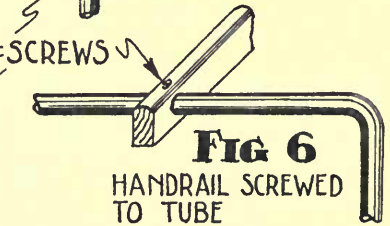

FIG 6

S M A L L S L I D E

The slide shown on the opposite page is for very small children. It is safe, easy to climb, and not too high for a child just able to climb the steps. The total height is 4' 0", width 2' 0", and it is 2' 9" from front to back. The chute is 7' 0" long. When not in use it stands upright against the front frame, hooked into brackets screwed to the top tread and bottom stretcher. The construction of the chute and hooks is described on Page 118.

C O N S T R U C T I O N

FRONT FRAMING.—On two boards 4' 0" \times 7" \times $\frac{3}{4}$ " mark out and cut two grooves, $\frac{3}{4}$ " wide and $\frac{1}{4}$ " deep, as shown in Fig. 4. Now pierce and shape the handles. An alternative suggestion for handles is shown in Fig. 1. On the front edges, $4\frac{1}{4}$ " up from the bottom, cut a mortice in each piece 2" \times $\frac{1}{4}$ " and $1\frac{1}{2}$ " deep for tenon of stretcher (Figs. 3 and 4). Cut two pieces 1' $10\frac{3}{4}$ " \times 7" \times $\frac{3}{4}$ " with square ends, for top tread and bottom stretcher. Clean up inside faces and glue and nail together with 2" oval nails (Figs. 1 and 3). Carefully check for squareness.

STEPS.—Prepare two boards 4' 0" \times 7" \times $\frac{3}{4}$ ". From Figs. 3 and 5 mark out these two "strings," taking care to "pair" them. The heavy lines in Fig. 5 show the cutting bevel. Shape the ends as Fig. 5 and cut the grooves $\frac{1}{4}$ " deep. The four treads are 1' $9\frac{1}{2}$ " \times 9" \times $\frac{3}{4}$ " with square ends. To economise material they may be reduced to 6" wide but the grooves should then be "stopped." Clean up the insides and glue and nail together, checking carefully for squareness (Fig. 2).

STRETCHERS.—Cut two 2' 0" \times 2" \times $\frac{3}{4}$ " and on one end of each cut a $\frac{1}{4}$ " tenon $1\frac{1}{2}$ " long. Fit these to mortices on front edge of uprights of framing (Fig. 3).

ASSEMBLY.—Clean up outsides of front framing and steps. Screw steps to inside of front framing (Fig. 3). Glue tenon of stretcher into mortice and screw other end to side of steps (Fig. 3). Punch in nails and paint or varnish finished slide.

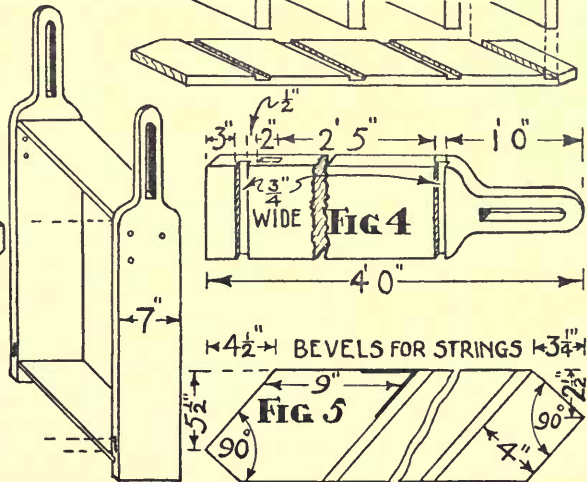
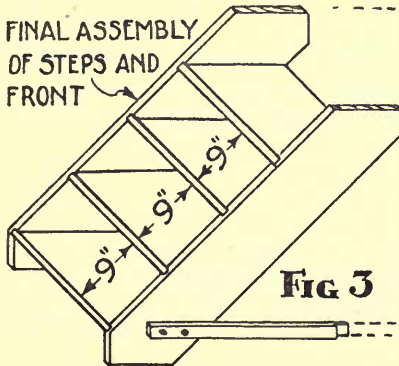
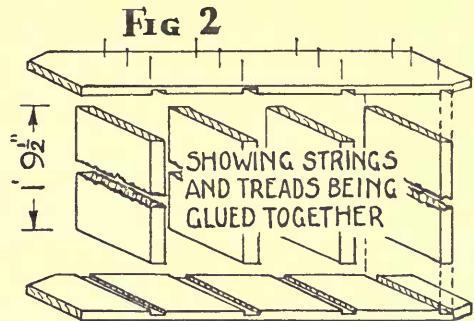
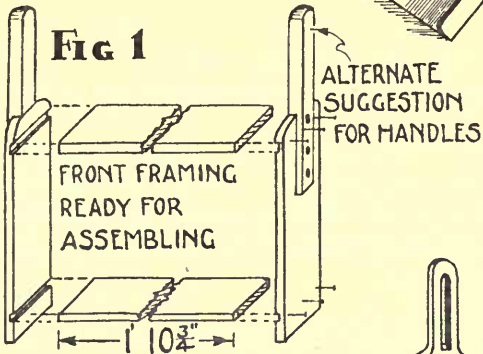
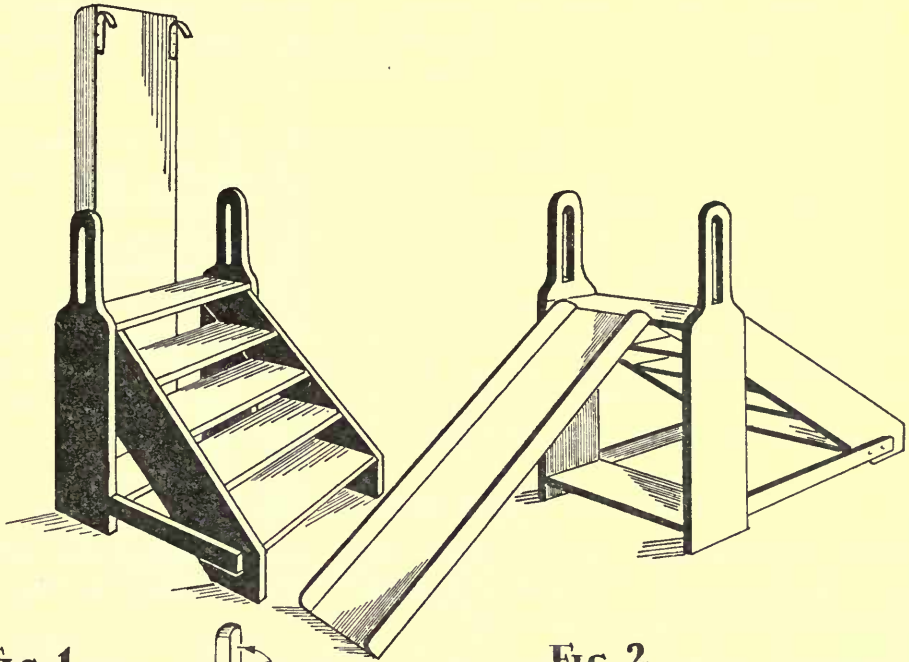

CLIMBING FRAME AND SLIDE

This thrilling piece of nursery apparatus, up which a child can climb to a "great" height and descend swiftly without hurt, consists of a framed tower 5' 6" high, 2' 0" wide and 1' 6" deep together with a slide or chute 9' 0" long and 1' 0" wide.

When in use (Fig. 2) the chute is attached to the tower by two hooks (Figs. 3 and 9) screwed to one end, which engage in two sockets (Figs. 4 and 8) attached to the platform rail of the tower. Three flat hooks (Figs. 5 and 9) screwed to the back of the chute hold it to the tower for storing away (Fig. 1). These should be placed so that the end of the chute rests on the floor, one flat hook engaging in a socket screwed to the bottom rail (Figs. 2 and 8), while the other two drop into the sockets used for hooking the chute to the tower. To render this hook-up easy the top hooks should be fixed to engage a little "late," i.e., they should commence to drop into the sockets after the bottom hook is already engaged for about half an inch of its length.

CONSTRUCTION OF TOWER

POSTS.—Four required each 5' 6" long by 1½" square. One of the front pair is shown in Fig. 6, and one of the back pair in Fig. 7. Carefully mark out the posts as a "set," then cut mortices to a depth of 7⁄8".

SIDE RAILS.—Six required each 1' 5" × 1½" × ¾" and four each 1' 5" × 2½" × ¾". The distance between the shoulders should be 1' 3" and the thickness of the tenon ¼".

FRONT AND BACK RAILS.—Four required each 1' 11" × 2½" × ¾" and three each 1' 11" × 1½" × ¾". The distance between the shoulders is 1' 9". The ends of intersecting tenons should be mitred. Extra length for the tenon may be gained by bringing the mortices nearer the face of the post instead of cutting them in the middle as shown in Figs. 6 and 7.

PLATFORM.—Five pieces each 2' 0" × 2½" × ¾" screwed to the rails with spaces of 5⁄8" between.

TO GLUE UP.—Clean up posts and rails. Glue **side framings first**, taking care they are square and flat. Clean off surplus glue. When set, glue and insert front and back rails, checking again for squareness. Screw down platform pieces.

CONSTRUCTION OF CHUTE

The chute is 9' 0" × 1' 0" and may be of one piece, or two or more 9' 0" lengths glued together. Light battens may be added if necessary. Complete by two edging pieces 9' 0" × 2½" × ¾" rounded on one edge and tongued and grooved, or screwed, to the edges of the wide piece.

FINISHING.—Screw hooks in positions indicated and paint in bright colours.

FIG 1

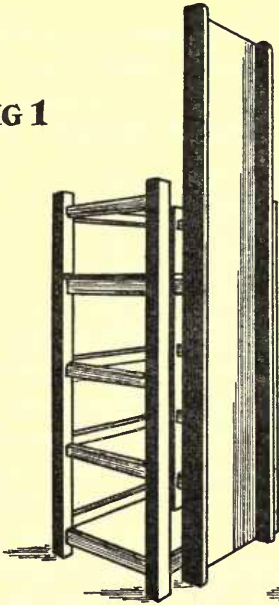

FIG 2

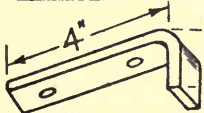
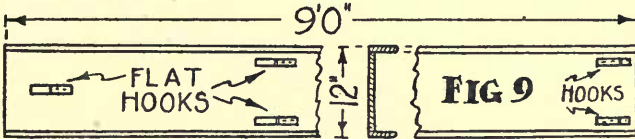
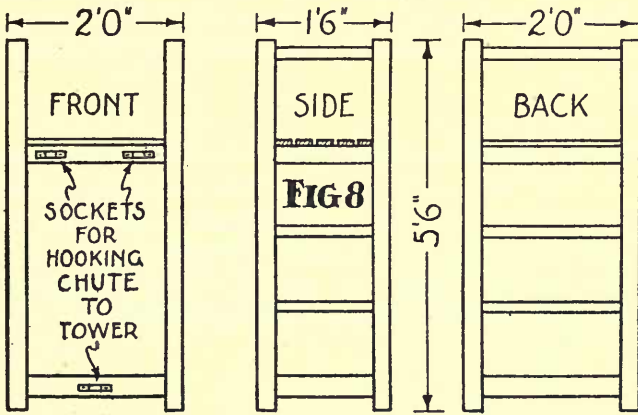
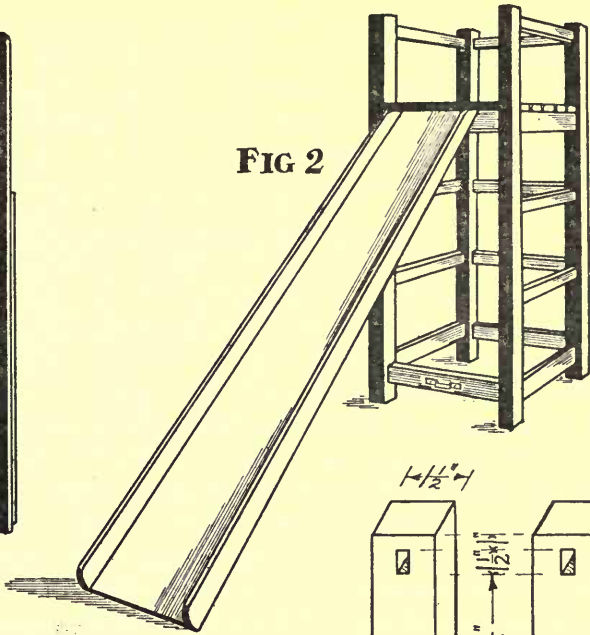

FIG 3

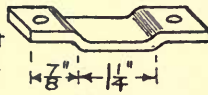

FIG 4

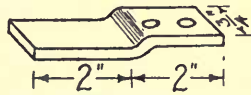

FIG 5

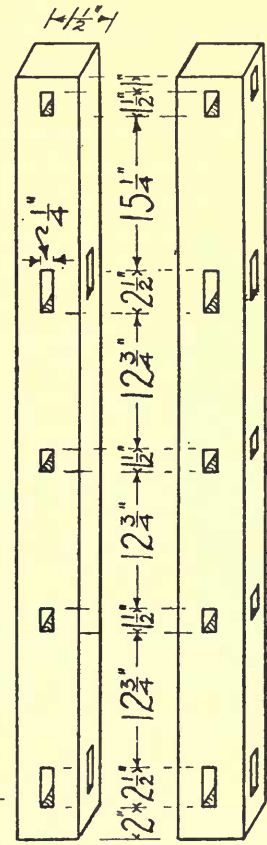

FIG 6

FIG 7

JUNGLE - GYM

This climbing frame or "Jungle-Gym" requires a large room or garden, but it provides amusement and valuable climbing exercise equally well for a group of children in a nursery as for the individual child in the home. The frame is 6' 0" × 6' 0" × 6' 0" with a central tower 7' 6" high. Deal is suggested for its construction.

CONSTRUCTION

Prepare four corner posts 6' 0" × 2½" × 2½" (Fig. 5). Mark out and cut the four ½" mortises in each (Figs. 3 and 5), and bore six ¾" holes, three in each side. The holes are 2" deep and are staggered (Fig. 5). Now prepare the eight intermediate posts on the outside of the frame, which are 6' 0" × 2" × 2". Cut bridle joints at top and bottom (Fig. 3). Mark out and bore holes from side to side to register with those on the near face of the corner posts. Bore holes also on the inner side 1½" deep to register with those on the corresponding face of the corner post. Note that the holes on either side of the "break" in front are not carried through. Four "tower" posts should now be prepared 7' 6" × 2" × 2". These should have "through" holes on all sides except at the top where the rods are level and in holes 1" deep (Fig. 2). Now cut and fit the seven long rails, which are 5' 10½" × 2½" × 7⁄8" (Fig. 4), and the two short rails on either side of the break, which are of the same section as the long ones and 1' 9" between the shoulders. Lastly cut twenty-three pieces of ¾" diameter rod, each 5' 11" long, and two pieces 2' 0½" long. Clean up all parts.

ASSEMBLY.—Glue together two opposite sides, taking great care that both are square. Frame up the "tower" with all the internal rods in position, then fasten the remaining intermediate posts to the ends of the rods passing through the tower. Glue and screw the five rails still left, including both short rails, to the posts. Slide the external rods, including the two short ones, into place and fasten on the two sides first glued up. Complete the frame by screwing into place the five battens forming the platform. These are 2' 1" × 3" × ¾".

NOTE.—Two 1¼" No. 12 screws should be put in each joint and one 1½" oval nail through each rod connection. It is very important, when gluing up and assembling, constantly to check for squareness and size.

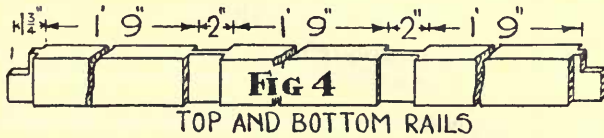
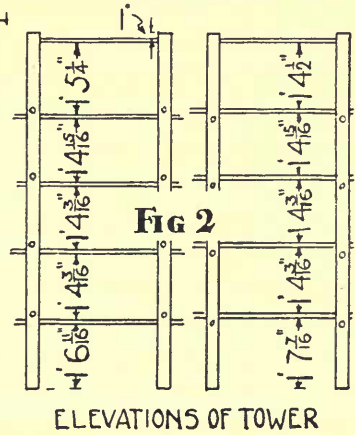
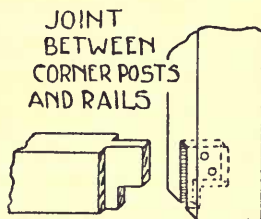
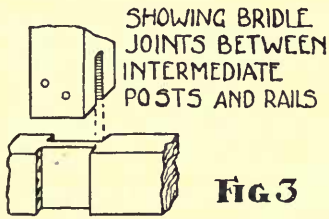
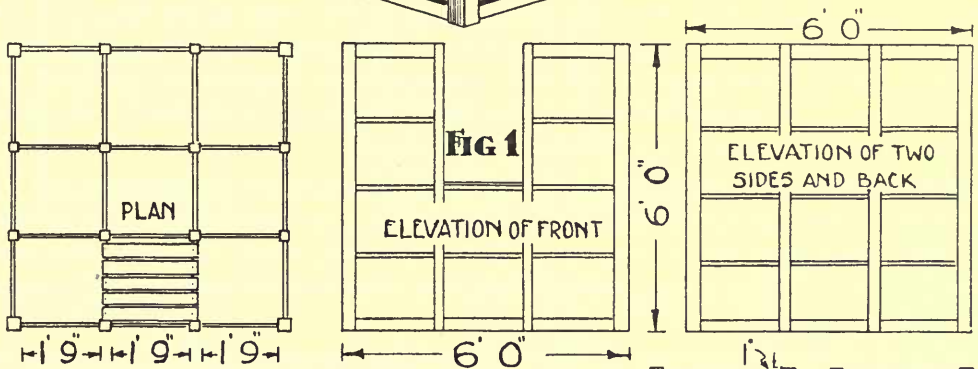
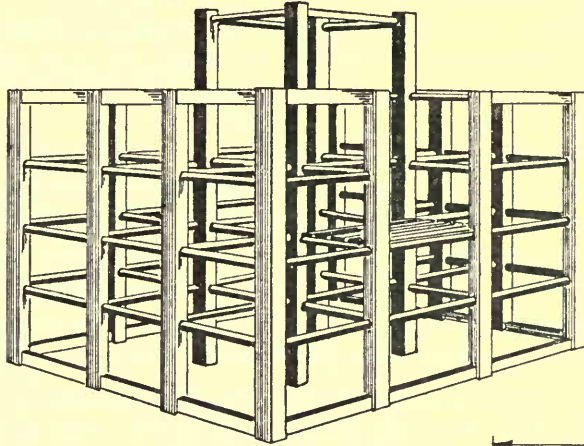

GENERAL HINTS

Below and on the opposite page are set out a few suggestions to help the less experienced worker. Most of the operations mentioned occur frequently in the constructions described throughout the book and their collection here will save needless repetition throughout the text.

SQUARING.—Two methods of squaring framing are illustrated in Fig. 1. Where the frame is large a “rod” is used. The frame is glued, cramped up, and adjusted until both diagonals are equal. The joints are then fixed by driving in the wedges. The second sketch shows the use of a try square for squaring a small frame.

NUMBERING JOINTS (Fig. 2).—As each joint is fitted together “dry” the several parts should be numbered as in Fig. 2. This ensures that the fitted parts are brought together again in correct position when the frame is finally assembled and glued up.

HINGING (Fig. 3).—One method is shown. Mark out position of hinge which should be clear of the corner joints. Set the marking gauge to the width of the flange, i.e., from the edge of the flange to the **centre** of the knuckle, and gauge this width on the edge of the frame. Now set the gauge to half the thickness of the hinge at the joint and mark this on the face. Cut out the sinking for the hinge. Note that at the back of the sinking the depth should be equal to the thickness of the flange.

SCREWING (Fig. 4).—Two pieces to be screwed together are shown in Fig. 4. First bore a hole of the same size as the shank of the screw, then make a start for the screw below this with a small drill or bradawl. Countersink the shank hole and screw pieces together. A little grease on the point of the screw helps both its entry and, if necessary, its later withdrawal.

NAILING.—Nails should always be driven obliquely into end grain so that they have a dovetail effect—see section on “Joints.”

BORING.—When boring through timber bore until the point of the bit just appears on the other side, then turn the piece over, insert the point of the bit in the small hole it previously made and complete the boring.

DOWELLING (Fig. 5).—Hold both pieces together in the vice and mark out the positions of the dowels. Set gauge to centre of piece and gauge as in Fig. 5. Bore holes 1" to 1½" deep. Cut dowels and make saw-cuts along them to allow air and surplus glue to escape from holes. Glue dowels into one side first, clean off squeezed-out glue, glue edges to be joined, place second piece over dowels and cramp up.

GLUING.—Use only clean, hot glue. Always apply glue to **all** parts to be joined and wash glue brush when finished.

SHAPING CURVES (Fig. 6).—After cutting with bow saw finish with flat spokeshave for outside curves and round spokeshave for inside curves (Fig. 6). Curves may be cut without bow or fretsaw. Convex curves may be cut with a tenon saw at a tangent to the curve, the ridges then being removed with flat spokeshave or chisel and file. For concave curves a series of saw-cuts are made to the curve and waste cleaned out with gouge.

(Continued on Page 124)

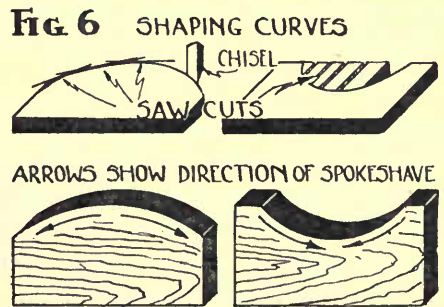
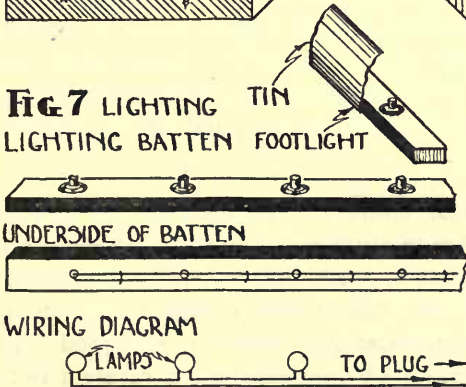
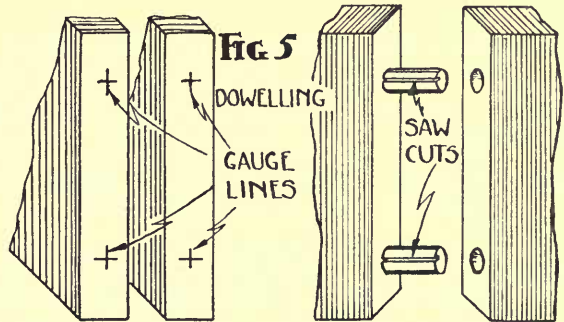
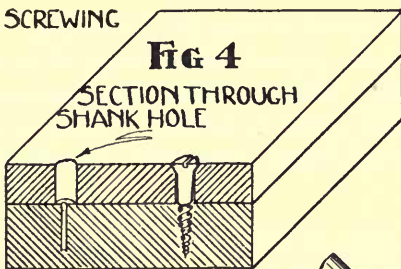
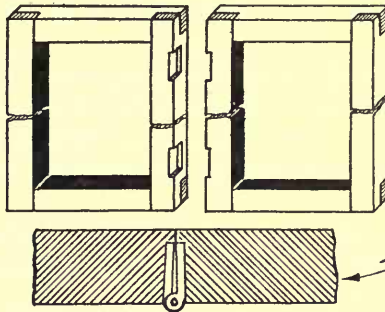
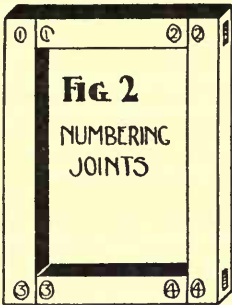
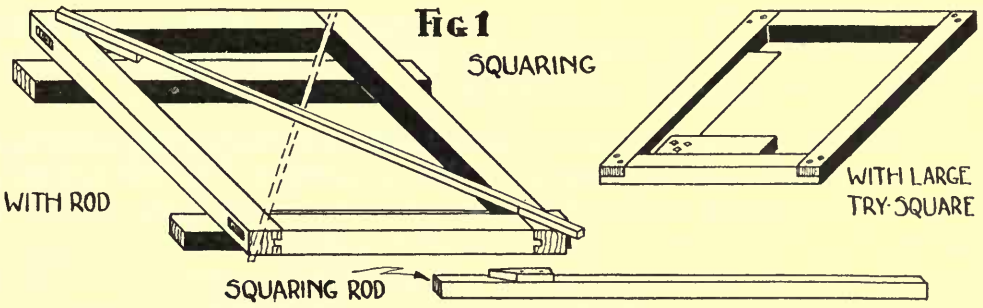

GENERAL HINTS—*continued*

STAGE LIGHTING (Fig. 7).—For the model theatre lamp holders may be screwed to a small batten and wired as shown. If a footlight is required a piece of tin-plate may be bent and screwed to the edge of the batten.

CURTAINS for the small theatres may be suspended from rings sliding along special extension wire or they may be hooked on runners travelling on brass rails sold for the purpose in most furnishing and hardware shops. In some cases a length of dowel rod may suffice.

FINISHING BY PAINTING OR STAINING

A bright and pleasing selection of colour greatly enhances the attractiveness of a toy and as much thought and care should be given to its general finishing as to its construction. Toys are usually finished by painting, or by staining followed by polishing or varnishing. Preparation for both is on similar lines.

PREPARATION.—Too much care cannot be given to this. Before the toy is assembled all parts should be cleaned up. After assembly the whole should be smoothed with glasspaper wrapped round a cork or wood block. Begin with M.2 glasspaper and finish with No. 1.

PAINTING.—Before painting all knots should be given a coat of “knotting” or French polish. A priming or undercoat should then be applied, after which all cracks or nail holes should be stopped with putty rubbed down when hard with fine glasspaper. Another undercoat should then be applied and rubbed down as before. Finally a coat of hard gloss paint or enamel should be given. Brushes should always be cleaned after use and tins of paint kept closed when not in use.

STAINING AND POLISHING.—There are three types of stain—water, oil and spirit. The last is best to use as it dries rapidly and is obtainable in a good range of attractive colours. Before staining it is advisable to damp the surfaces with clean warm water in order to raise the short particles of grain. When dry they should be smoothed again with fine glasspaper. Apply the stain by means of brush or cloth and, when dry, follow with a coat of varnish or polish.

SELECTION OF COLOUR.—Bright, cheerful colours should always be used but care should be exercised in their selection. Large surfaces of contrasting colour may have a disturbing effect, but the same colours if one is predominant may be very pleasing, e.g., where the broad surfaces are painted in one colour and a contrasting colour is used for the edges or smaller parts. On broad surfaces grey offers a very good “background” for most colours except black. White, for obvious reasons, is rarely a suitable colour. Very useful colours are Signal Red, Emerald Green, Chrome Yellow, Ultramarine, French Grey and Black.

T O O L S

Below is set out a list of tools with which the toymaker can construct all the toys described in this book. The beginner is advised to buy them singly and not in sets, and if possible to get a carpenter friend to help him to select them. For the construction of many of the toys the short list of tools marked by an asterisk will suffice.

Jack plane ; *Smoothing plane, metal if possible ; Plough plane ; Panel saw ; *Tenon saw, 12 in. ; Bow saw, 8 in. ; Hacksaw ; *Try square, 6 in. ; *Rule, 2 ft., four-fold ; Mortice gauge ; Marking gauge ; Spokeshaves, one flat and one round ; Glue pot ; *Mallet ; *Hammer, No. 2 ; *Screwdrivers, one large and one small ; *Brace ; *Centre bits, $\frac{1}{4}$ " , $\frac{1}{2}$ " , $\frac{5}{8}$ " , $\frac{3}{4}$ " , 1" ; Hand drill ; Morse drills, $\frac{1}{8}$ " , $\frac{3}{16}$ " , $\frac{1}{4}$ " ; *Chisels, firmer, $\frac{1}{4}$ " , $\frac{1}{2}$ " , $\frac{3}{4}$ " , 1" ; Pincers ; Bradawl ; " G " cramps, two ; Sash cramps, two, 30" ; *Oil stone, " India Combination " ; Tinman's snips ; Nail punch ; Centre punch ; File, half round, 10" bastard cut.

University of California
SOUTHERN REGIONAL LIBRARY FACILITY
Return this material to the library
from which it was borrowed.

REC'D LD-URL
QL JAN 17 1988
REC'D LD-URL OCT 13 1988

OCT 13 1988



3 1158 01098 819

UC SOUTHERN REGIONAL LIBRARY FACILITY



A 000 031 969

Univer
Sou
Li