

ICS 53.020.30

Descriptors: lifting chains, welded chains, chain links, steels, lifting slings, safety, accident prevention, hazards, dimensions, chemical composition, mechanical properties, tests, verification

English version

**Short link chain for lifting purposes - Safety - Part
2: Medium tolerance chain for chain slings - Grade
8**

Chaînes de levage à maillons courts - Sécurité
- Partie 2: Chaîne de tolérance moyenne pour
élingues en chaînes - Classe 8

Kurzgliedrige Rundstahlketten für Hebezwecke -
Sicherheit - Teil 2: Mitteltolerierte
Rundstahlketten für Anschlagketten - Güteklasse
8

In case of changes this printout is not taken into account!
Besides this is a copy and only for in-house purposes of
SMS Schloermann-Siemag AG. (acc. to DIN reference sheet 3)

This European Standard was approved by CEN on 1996-03-07. CEN members are bound to comply with the CEN/CENELEC Internal Regulations which stipulate the conditions for giving this European Standard the status of a national standard without any alteration.

Up-to-date lists and bibliographical references concerning such national standards may be obtained on application to the Central Secretariat or to any CEN member.

The European Standards exist in three official versions (English, French, German). A version in any other language made by translation under the responsibility of a CEN member into its own language and notified to the Central Secretariat has the same status as the official versions.

CEN members are the national standards bodies of Austria, Belgium, Denmark, Finland, France, Germany, Greece, Iceland, Ireland, Italy, Luxembourg, Netherlands, Norway, Portugal, Spain, Sweden, Switzerland and United Kingdom.

CEN

European Committee for Standardization
Comité Européen de Normalisation
Europäisches Komitee für Normung

Central Secretariat: rue de Stassart, 36 B-1050 Brussels

Contents		Page
	Foreword	3
0	Introduction	4
1	Scope	5
2	Normative references	5
3	Definitions	6
4	Hazards	6
5	Safety requirements	7
6	Verification of safety requirements	11
7	Marking	12
8	Manufacturers certificate	13
9	Instructions for use	13
Annexes		
Annex A	(informative) Calculation of dimensions, working load limits and mechanical properties	14
Annex B	(informative) Weight of chain	17
Annex C	(informative) Designation system for chain	18

Foreword

This European Standard has been prepared by Technical Committee CEN/TC 168 "Chains, ropes, webbing, slings and accessories - Safety" of which the secretariat is held by BSI.

This European Standard shall be given the status of a national standard, either by publication of an identical text or by endorsement, at the latest by December 1996, and conflicting national standards shall be withdrawn at the latest by December 1996.

This European Standard has been prepared under a mandate given to CEN by the European Commission and the European Free Trade Association, and supports essential requirements of EU Directive(s).

The other parts of EN 818 are:

- Part 1: General conditions of acceptance
- Part 3: Medium tolerance chain for chain slings - Grade 4
- Part 4: Chain slings - Grade 8
- Part 5: Chain slings - Grade 4
- Part 6: Chain slings - Instructions for use and maintenance.

A further part or parts will cover fine tolerance chains for chain hoists and other lifting appliances.

This is the first edition of this Part of EN 818.

According to the CEN/CENELEC Internal Regulations, the national standards organizations of the following countries are bound to implement this European Standard: Austria, Belgium, Denmark, Finland, France, Germany, Greece, Iceland, Ireland, Italy, Luxembourg, Netherlands, Norway, Portugal, Spain, Sweden, Switzerland and United Kingdom.

0 Introduction

This European standard has been prepared to be a harmonised standard to provide one means of conforming with the essential safety requirements of the Machinery Directive.

The Directive stipulates that where chain with welded links is used for lifting accessories it is to be of short link type and for the purposes of this standard this is chain having a ratio of nominal pitch to nominal size of 3:1.

The extent to which hazards are covered is indicated in the scope of this Part of EN 818. In addition, lifting equipment shall comply as appropriate with EN 292 for hazards which are not covered by this standard.

Annex C gives a designation system for recording the identifying features of grade 8 short link chain. Since this system is not widely used it has been included in this first edition of this standard as an informative annex, however, should its use become more generally accepted then the status of the information would need to be reviewed.

1 Scope

This Part of EN 818 specifies the requirements related to safety for short link lifting chains, Grade 8, of medium tolerance for use in chain slings and for general lifting purposes. They are electrically welded round steel short link chains, heat treated and tested and complying with the general conditions of acceptance in EN 818-1.

The range of nominal sizes of chain covered by this Part of EN 818 is from 4 mm to 45 mm.

The hazards covered by this Part of EN 818 are identified in clause 4.

The bases for calculation of tabulated values for dimensions, working load limits and mechanical properties are given in annex A.

Annex B gives information on weight/metre of chain.

Annex C gives an example of a designation system for chains.

2 Normative references

This European Standard incorporates by dated or undated reference provisions from other publications. These normative references are cited at the appropriate places in the text and the publications are listed hereafter. For dated references, subsequent amendments to, or revisions of, any of these publications apply to this European Standard only when incorporated in it by amendment or revision. For undated references the latest edition of the publication referred to applies.

EN 292-1	Safety of machinery - Basic concepts - General principles for design Part 1: Basic terminology methodology
EN 292-2: 1991	Safety of machinery - Basic concepts - General principles for design Part 2: Technical principles and specifications
EN 292-2: 1991 /A1:1995	Safety of machinery - Basic concepts - General principles for design Part 2: Technical principles and specifications
EN 818-1	Short link chain for lifting purposes - Safety Part 1: General conditions of acceptance
prEN 818-6	Short link chain for lifting purposes - Safety Part 6: Chain slings - Instructions for use and maintenance
prEN 1050	Safety of machinery - Risk assessment

3 Definitions

For the purposes of this Part of EN 818 the definitions given in EN 818-1 apply.

4 Hazards

The release of a load due to failure of lifting accessories such as slings or their component parts puts at risk either directly or indirectly the life or health of those persons within the danger zone of lifting equipment.

In order to provide the necessary strength and durability of lifting accessories this Part of EN 818 lays down requirements for the design, selection of materials of construction and testing to ensure that specified levels of performance are met.

Fatigue failure has not been identified as a hazard when chain having the specified levels of performance given in this Part of EN 818 is used in general lifting service.

Since failure can be caused by the incorrect choice of grade and specification of lifting accessories this Part of EN 818 also gives the requirements for marking and the manufacturers certificate.

Those aspects of safe use associated with good practice are given in prEN 818-6.

Table 1 contains all the hazards, which require action to reduce risk identified by risk assessment as being specific and significant for short link chain (medium tolerance) grade 8 for lifting purposes.

Table 1: Hazards and associated requirements

Hazards identified in annex A of prEN 1050		Relevant clause of annex A of EN 292-2: 1991/A1: 1995	Relevant clause/ sub-clause of this standard
1.1.5	Mechanical hazard due to inadequacy of strength	1.3.2	5
		4.1.2.3	
		4.1.2.4	
		4.2.4	6
		1.7.3	7
4.3.1			

5 Safety requirements

5.1 General

The chain shall also comply with the appropriate requirements of EN 818-1.

5.2 Dimensions

5.2.1 Nominal size of chain, d_n

The nominal size of chain shall be one of the sizes listed in table 2 column 1.

5.2.2 Tolerance on material diameter (except at the weld)

The tolerance on material diameter for each nominal size of chain shall be in accordance with table 2 column 2.

5.2.3 Weld diameter

The maximum diameter at the weld for each nominal size of chain shall be in accordance with table 2 column 3. The thickness of the steel at the weld shall nowhere be less than the actual diameter of the steel adjacent to the weld.

5.2.4 Length dimensionally affected by welding

The length dimensionally affected by welding (e) shall not extend by more than $0,6 d_n$ to either side of the centre of the link.

5.2.5 Pitch and widths

The dimensions of the pitch and widths of the individual links and chain shall be as specified in table 2 columns 4 to 8, and illustrated in figure 1 of EN 818-1.

Table 2: Dimensions

Dimensions in millimetres							
(1)	(2)	(3)	(4)	(5)	(6)	(7)	(8)
Nominal Size d_n	Material diameter tolerance	Weld diameter d_w max	Pitch			Internal width away from weld w_1 min	External width over the weld w_2 max
			p_n	p max	p min		
4	± 0,16	4,4	12	12,4	11,6	5,2	14,8
5	± 0,2	5,5	15	15,5	14,6	6,5	18,5
6	± 0,24	6,6	18	18,5	17,5	7,8	22,2
7	± 0,28	7,7	21	21,6	20,4	9,1	25,9
8	± 0,32	8,8	24	24,7	23,3	10,4	29,6
10	± 0,4	11	30	30,9	29,1	13	37
13	± 0,52	14,3	39	40,2	37,8	16,9	48,1
16	± 0,64	17,6	48	49,4	46,6	20,8	59,2
18	± 0,9	19,8	54	55,6	52,4	23,4	66,6
19	± 1	20,9	57	58,7	55,3	24,7	70,3
20	± 1	22	60	61,8	58,2	26	74
22	± 1,1	24,2	66	68	64	28,6	81,4
23	± 1,2	25,3	69	71,1	66,9	29,9	85,1
25	± 1,3	27,5	75	77,3	72,8	32,5	92,5
26	± 1,3	28,6	78	80,3	75,7	33,8	96,2
28	± 1,4	30,8	84	86,5	81,5	36,4	104
32	± 1,6	35,2	96	98,9	93,1	41,6	118
36	± 1,8	39,6	108	111	105	46,8	133
40	± 2	44	120	124	116	52	148
45	± 2,3	49,5	135	139	131	58,5	167

5.3 Materials and heat treatment

5.3.1 Quality of material

5.3.1.1 General

Within the limitations given in 5.3.1.2 to 5.3.1.4 it is the responsibility of the chain manufacturer to select the type of steel to be used so that the finished chain, when suitably heat-treated meets the mechanical properties specified in this Part of EN 818.

5.3.1.2 Type of steel

The steel used shall be produced by an electric process or by an oxygen blown process.

5.3.1.3 Deoxidation

The steel shall be fully killed, be stabilized against strain age embrittlement and have an austenitic grain size of 5 or finer when tested in accordance with ISO 643.

5.3.1.4 Chemical composition

The steel shall contain alloying elements in sufficient quantities so that the finished chain, when heat treated in accordance with 5.3.2, complies not only with the mechanical properties specified in this Part of EN 818 but also possesses adequate low temperature ductility and toughness to provide resistance to impact loading.

The steel shall contain nickel and at least one of the other elements in the minimum percentages shown in table 3.

Table 3: Chemical composition-alloying elements

Element	Minimum mass content % as determined by cast analysis
Nickel	0,40
Chromium	0,40
Molybdenum	0,15

To ensure that chain is stabilized against strain-age embrittlement during service, the steel shall contain at least 0,025 % aluminium.

The steel shall contain no more sulfur and phosphorus content than the limits given in table 4.

Table 4: Sulfur and phosphorus content

Element	Maximum mass content % as determined by	
	Cast analysis	Check analysis
Sulfur	0,025	0,030
Phosphorus	0,025	0,030

5.3.2 Heat treatment

All the chain shall be hardened from a temperature above the AC3 point and tempered before being subjected to the manufacturing proof force. The tempering temperature shall be at least 400 °C.

The tempering conditions shall be at least as effective as a temperature of 400 °C maintained for a period of 1 h. This requirement is the responsibility of the chain manufacturer. When proposed for verification, sample chains shall be tested after they have been reheated to and maintained for 1 h at 400 °C and then cooled to room temperature; they shall comply with the requirements of 5.4.2 and 5.4.3.

5.4 Mechanical properties

5.4.1 Manufacturing proof force (MPF)

All the chain shall be subjected to the manufacturing proof force specified in table 5, column 3 for the appropriate nominal size of chain.

5.4.2 Breaking force (BF) and total ultimate elongation (A)

Samples of chain in the finished condition shall have a breaking force at least equal to that specified in table 5, column 4 for the appropriate nominal size of chain. On completion of the static tensile test the total ultimate elongation as defined in EN 818-1 shall be not less than 20 %.

5.4.3 Bend deflection

Single link samples shall withstand the minimum deflection specified in table 5, column 5 for the appropriate nominal size of chain and shall be free from visible defects.

Table 5: Working load limits and test requirements

1	2	3	4	5
Nominal size d_n mm	Working load limit WLL t	Manufacturingp roof force MPF kN	Breaking force BF kN min	Bend deflection f mm min
4	0,5	12,6	20,1	3,2
5	0,8	19,6	31,4	4
6	1,12	28,3	45,2	4,8
7	1,5	38,5	61,6	5,6
8	2	50,3	80,4	6,4
10	3,15	78,5	126	8
13	5,3	133	212	10
16	8	201	322	13
18	10	254	407	14
19	11,2	284	454	15
20	12,5	314	503	16
22	15	380	608	18
23	16	415	665	18
25	20	491	785	20
26	21,2	531	849	21
28	25	616	985	22
32	31,5	804	1290	26
36	40	1020	1630	29
40	50	1260	2010	32
45	63	1590	2540	36

6 Verification of safety requirements

6.1 Size of lot and selection of samples

The size of the lot from which samples shall be selected shall be 200 m. An excess fraction of the length of lot shall be considered as a separate lot. Samples shall be selected as specified in EN 818-1.

6.2 Manufacturing proof force, breaking force and total ultimate elongation

6.2.1 Static tensile test

The testing machine and test procedure for the static tensile test shall be as specified in EN 818-1.

6.2.2 Manufacturing proof force acceptance criteria

All the chain shall sustain the manufacturing proof force specified in 5.4.1.

6.2.3 Breaking force and total ultimate elongation acceptance criteria

On completion of the static tensile test the requirements of 5.4.2 shall be met.

6.3 Bend deflection

6.3.1 Bend test

The test equipment and procedure shall be as specified in EN 818-1.

Each single link sample shall be bent to a minimum deflection, "f", as shown in figure 1 and given in table 5, column 5.

Following the removal of the force, the link sample shall be examined by a competent person.

NOTE: Where necessary a surface coating may be removed after the bend test to enable this examination to be carried out.

6.3.2 Bend deflection acceptance criteria

On completion of the bend test the requirements of 5.4.3 shall be met.

7 Marking

Marking shall be as specified in EN 818-1.

The grade mark for the chain shall be "8".

8 Manufacturers certificate

The manufacturers certificate shall be as specified in EN 818-1.

9 Instructions for use

Instructions for use shall accompany the chain and shall be in accordance with the relevant clauses of prEN 818-6.

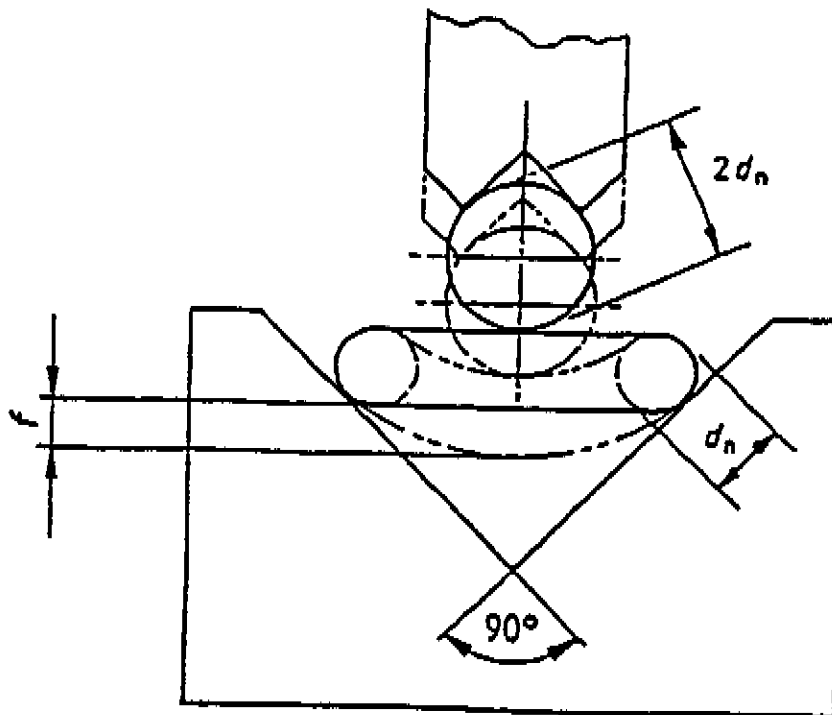

Figure 1: Bend deflection " f "

Annex A (informative)

Calculation of dimensions, working load limits and mechanical properties

A.1 Dimensions and tolerances

A.1.1 In table 2 column 2 the tolerances on material diameters are based on:

- a) $\pm 4\%$ of the nominal size of chain for nominal sizes less than 18 mm;
- b) $\pm 5\%$ of the nominal size of chain for nominal sizes of 18 mm and over, values being rounded to 0,1 mm.

A.1.2 The bases for calculation of dimensions in table 2 columns 3 to 8 are as follows:

Maximum diameter at the weld	$d_{s\max} = 1,1 d_n$
Nominal pitch	$p_n = 3 d_n$
Minimum pitch of chain	$p_{\min} = 2,91 d_n$
Maximum pitch of chain	$p_{\max} = 3,09 d_n$
Minimum internal width, away from the weld	$w_1 = 1,3 d_n$
Maximum external width, over the weld	$w_2 = 3,7 d_n$

Dimensions given in table 2 are full calculated values rounded to 0,1 mm for values up to 100 mm. Values equal to or greater than 100 mm are rounded to 1 mm.

A.2 Working load limits and mechanical properties

A.2.1 General

The stresses used in the calculation of working load limits and mechanical properties in the formulae given in A.2.2 to A.2.4 are mean stresses as follows:

- 1) Mean stress at the working load limit (WLL) = 200 N/mm²;
- 2) Mean stress at the manufacturing proof force (MPF) = 500 N/mm²;
- 3) Mean stress at the breaking force (BF_{min}) = 800 N/mm².

A.2.2 Calculated values of working load limit (WLL)

The values of working load limit are based on the full calculated WLL values determined using the following formula:

$$WLL = \frac{2 \times \frac{1}{4} \times \pi \times 200 \times d_n^2}{g \times 1000} \text{ in } t$$

$$WLL = 0,0320353 d_n^2 \text{ in } t$$

where

WLL is expressed in tonnes, and

g = acceleration due to gravity (in m/s^2 i.e. 9,80665).

The values given in table 5, column 2 are from the R40 series of preferred numbers and represent the nearest lower R40 value relative to the full calculated value of WLL.

A.2.3 Calculated values of manufacturing proof force (MPF)

The values of manufacturing proof force are based on the full calculated MPF values determined using the following formula:

$$MPF = \frac{2 \times \frac{1}{4} \times \pi \times 500 \times d_n^2}{1000} \text{ in } kN$$

$$MPF = 0,7853982 d_n^2 \text{ in } kN$$

The values given in table 5, column 3 have been rounded to 0,1 kN up to 100 kN. Values equal to or greater than 100 kN, up to 1000 kN, are rounded to 1 kN and values 1000 kN or greater rounded to 10 kN.

A.2.4 Calculated values of minimum breaking force (BF_{min})

The values of minimum breaking force are based on the full calculated BF_{min} values determined using the following formula:

$$BF_{min} = \frac{2 \times \frac{1}{4} \times \pi \times 800 \times d_n^2}{1000} \text{ in } kN$$

$$BF_{min} = 1,2566371 d_n^2 \text{ in } kN$$

The values given in table 5, column 4 have been rounded to 0,1 kN up to 100 kN. Values equal to or greater than 100 kN, up to 1000 kN, are rounded to 1 kN and values 1000 kN or greater rounded to 10 kN.

A.2.5 Bend deflection (*f*)

The values of bend deflection have been calculated using the following formula:

$$f = 0,8 \times d_n \text{ in } mm$$

The values given in table 5 column 5 have been rounded to 0,1 mm up to 10 mm. Values greater than 10 mm are rounded to 1 mm.

Annex B (informative)

Weight of chain

The approximate weight/metre of chain based on a mass density of 7,85 g/cm³ is given in table B.1.

Table B.1: Weight of chain

Nominal size	Weight
mm	kg/m
4	0,35
5	0,5
6	0,8
7	1,1
8	1,4
10	2,2
13	3,8
16	5,7
18	7,3
19	8,1
20	9
22	10,9
23	12
25	14,1
26	15,2
28	17,6
32	23
36	29
40	36
45	45,5

Annex C (Informative)

Designation system for chain (medium tolerance) - grade 8

General format

