



Pressure gauges
Part 3: Diaphragm and capsule pressure gauges – Dimensions,
metrology, requirements and testing
English version of DIN EN 837-3

DIN
EN 837-3

ICS 17.100

Descriptors: Pressure gauges, requirements, testing.

Druckmeßgeräte – Teil 3: Druckmeßgeräte mit Platten- und
Kapselfedern – Maße, Meßtechnik, Anforderungen und Prüfung

This standard supersedes
DIN 16013:1987-02,
DIN 16014:1987-02,
DIN 16026:1987-02,
DIN 16027:1987-02, and,
together with
DIN EN 837-1:1997-02,
supersedes
DIN 16005:1987-02,
DIN 16007:1987-02,
DIN 16099:1987-02,
DIN 16109:1987-02,
DIN 16117:1987-02,
DIN 16123:1987-02,
DIN 16128:1987-02,
DIN 16254:1983-02,
DIN 16258:1987-02, and
DIN 16288:1987-02.

European Standard EN 837-3:1996 has the status of a DIN Standard.

A comma is used as the decimal marker.

National foreword

This standard has been prepared by CEN/TC 141.

The responsible German body involved in its preparation was the *Normenausschuß Technische Grundlagen* (Principles of Standards Work Standards Committee).

Although this standard only covers pressure gauges of circular form, it may also be applied by analogy to gauges of square or rectangular form. It should be noted that the pressure connections and tapped holes specified in this standard are also suitable for use with DIN 16086 gauges and transducers, as well as transducers common in process engineering.

Since this standard specifies only dimensions for sealing washers and lenses, but no materials and pressure/temperature ratings, information on these parameters, so far included in DIN 16258 and DIN 16259 (now withdrawn), is provided in the tables below.

Continued overleaf.
EN comprises 26 pages.

Bearbeitet: **Normung**

18.9.03

Table 1: Washer materials

Material	Allowable working pressure, in bar	Allowable working temperature, in °C	Hardness of ready-to-use washer
Non-metallic (asbestos-free)	100	250	-
Al 99,5 F13 as in DIN 1745-1	250	100	≈ HB 40
SF-Cu F20 as in DIN 17670-1	400 (1 600)	400	HB 40 to HB 60
X 6 CrNiMoTi 17 12 2 as in DIN 17440	400	550	HB 130 to HB 190
Ni 99,6 F37 (soft-annealed) as in DIN 17750	400	600	HB 110 maximum
The values given in brackets apply to flush mounting or similar types of mounting.			

The DIN Standards corresponding to the European/International Standards referred to in clause 2 of the EN are as follows:

European/International Standard	DIN Standard
EN 22768-1	DIN ISO 2768-1
ISO 228-1	DIN ISO 228-1
ISO 1302	DIN ISO 1302
ISO 2859-1	DIN ISO 2859-1

Amendments

The specifications of the standards listed in the Superseding note have been combined to form the present standard (and DIN EN 837-1).

Previous editions

DIN 3704: 1925-07	DIN 16110: 1942-08, 1954-03, 1962-06
DIN 3705: 1925-07	DIN 16117: 1987-02
DIN 16005: 1968-11, 1987-02	DIN 16117-1: 1979-10
DIN 16005-1: 1981-07	DIN 16117-2: 1967-11, 1983-10
DIN 16005-2: 1981-07	DIN 16117-3: 1979-10
DIN 16010-1: 1942-06, 1962-06	DIN 16123: 1987-02
DIN 16011: 1942-06	DIN 16123-1: 1977-04
DIN 16012: 1942-06	DIN 16123-2: 1967-10, 1977-04
DIN 16013: 1965-05, 1976-01, 1987-02	DIN 16123-3: 1977-04
DIN 16014: 1965-05, 1976-01, 1987-02	DIN 16123-4: 1977-04
DIN 16020: 1942-06	DIN 16128: 1974-03, 1987-02
DIN 16021: 1942-06, 1963-06	DIN 16128-1: 1965-06
DIN 16022: 1942-06, 1962-06	DIN 16128-2: 1965-06
DIN 16026: 1965-05, 1976-01, 1987-02	DIN 16128-3: 1965-06
DIN 16027: 1965-05, 1976-01, 1987-02	DIN 16254: 1961-10, 1983-02
DIN 16109: 1965-05, 1987-02	DIN 16258: 1987-02
DIN 16109-1: 1973-12	DIN 16288: 1964-09, 1972-04, 1985-09, 1987-02
DIN 16109-2: 1983-02	

Standards referred to

(and not included in **Normative references**)

DIN 1745-1	Wrought aluminium and aluminium alloy plate, sheet and strip greater than 0,35 mm in thickness – Properties
DIN 16086	Electrical pressure measuring instruments – Pressure sensors, pressure transmitters, pressure measuring instruments – Concepts, specifications for data sheets
DIN 17440	Technical delivery conditions for stainless steel plate, hot rolled strip, and bars for pressure purposes, drawn wire and forgings
DIN 17670-1	Wrought copper and copper alloy plate, sheet and strip – Properties
DIN 17750	Wrought nickel and nickel alloy plate, sheet and strip – Properties

ICS 17.100

Descriptors: Pressure gauges, requirements, testing.

English version

Pressure gauges

**Part 3: Diaphragm and capsule pressure gauges
Dimensions, metrology, requirements and testing**

Manomètres – Partie 3: Manomètres à membrane et manomètres à capsule – Dimensions, métrologie, prescriptions et essais

Druckmeßgeräte – Teil 3: Druckmeßgeräte mit Platten- und Kapselfedern – Maße, Meßtechnik, Anforderungen und Prüfung

This European Standard was approved by CEN on 1996-10-30.

CEN members are bound to comply with the CEN/CENELEC Internal Regulations which stipulate the conditions for giving this European Standard the status of a national standard without any alteration.

Up-to-date lists and bibliographical references concerning such national standards may be obtained on application to the Central Secretariat or to any CEN member.

The European Standards exist in three official versions (English, French, German). A version in any other language made by translation under the responsibility of a CEN member into its own language and notified to the Central Secretariat has the same status as the official versions.

CEN members are the national standards bodies of Austria, Belgium, the Czech Republic, Denmark, Finland, France, Germany, Greece, Iceland, Ireland, Italy, Luxembourg, the Netherlands, Norway, Portugal, Spain, Sweden, Switzerland, and the United Kingdom.

CEN

European Committee for Standardization
Comité Européen de Normalisation
Europäisches Komitee für Normung

Central Secretariat: rue de Stassart 36, B-1050 Brussels

Contents

Foreword	2
1 Scope	3
2 Normative references	3
3 Definitions	3
4 Nominal sizes	4
5 Pressure ranges	4
6 Accuracy classes	4
7 Dimensions	5
8 Wetted parts	11
9 Requirements	11
10 Testing	17
11 Packaging for transportation	20
12 Designation	21
Annex A (informative) Examples of scale numbering for accuracy classes from 0,6 to 4	22
Annex B (informative) Examples of flanged and special connections	26

Foreword

This European Standard has been prepared by Technical Committee CEN/TC 141 "Pressure gauges - Thermometers - Means of measuring and/or recording temperature during the distribution of refrigerated frozen and quick-frozen products", the secretariat of which is held by AFNOR.

This European Standard shall be given the status of a national standard, either by publication of an identical text or by endorsement, at the latest by June 1997, and conflicting national standards shall be withdrawn at the latest by June 1997.

This European Standard is a part of the series of the following standards:

- EN 837-1 Pressure gauges - Part 1: Bourdon tube pressure gauges - Dimensions, metrology, requirements and testing;
- EN 837-2 Pressure gauges - Part 2: Selection and installation recommendations for pressure gauges;
- EN 837-3 Pressure gauges - Part 3: Diaphragm and capsule pressure gauges - Dimensions, metrology, requirements and testing.

According to the CEN/CENELEC Internal Regulations, the national standards organizations of the following countries are bound to implement this European Standard: Austria, Belgium, Denmark, Finland, France, Germany, Greece, Iceland, Ireland, Italy, Luxembourg, Netherlands, Norway, Portugal, Spain, Sweden, Switzerland and the United Kingdom.

1 Scope

This European Standard specifies requirements for diaphragm and capsule (designated by D and C respectively, see clause 12) indicating pressure gauges, vacuum gauges and combined vacuum and pressure gauges (compound gauges), from 50 to 250 nominal size with ranges up to 25 bar for the measurement of gauge pressure.

A reading of zero bar is atmospheric pressure. 1 bar = 10^5 Pa.

Gauges specified have circular dials with concentric scales for industrial use.

The standard includes methods of test for performance to be applied at type approval and production piece tests.

The standard applies to gauges suitable for industrial use with common industrial fluids. It does not apply to pressure gauges for oxygen or acetylene use nor gauges with electrical contacts.

Pressure gauges for welding, cutting and associated processes are not included in this standard, but are specified in EN 562.

2 Normative references

This European Standard incorporates, by dated or undated reference, provisions from other publications. These normative references are cited at the appropriate places in the text and the publications are listed hereafter. For dated references, subsequent amendments to or revisions of any these publications apply to this European Standard only when incorporated in it by amendment or revision. For undated references the latest edition of the publication referred to applies.

ANSI/ASME B1.20.1

Pipe threads, general purpose (inch)

EN 472 : 1994

Pressure gauges – Vocabulary

EN 562 : 1994

Gas welding equipment – Pressure gauges used for welding, cutting and allied processes

EN 60529 : 1991

Degrees of protection provided by enclosures

EN 60068-2-6 : 1995

Electrical engineering; basic environmental testing procedures – Part 2: Tests - Test Fc and guidance: Vibration (sinusoidal)

EN 60068-2-27 : 1993

Electrical engineering; basic environmental testing procedures – Part 2: Tests - Test Ea and guidance: Shock

ISO 228-1 : 1994

Pipe threads where pressure-tight joints are not made on the threads – Part 1: Dimensions tolerances and designation

ISO 1302 : 1992

Technical drawings – Methods of indicating surface texture on drawings

EN 22768-1 : 1993

General tolerances – Part 1: Tolerances for linear and angular dimensions without individual tolerance indications

ISO 2859-1 : 1989

Sampling procedures for inspection by attributes – Part 1: Sampling plans indexed by acceptable quality level (AQL) for lot-by-lot inspection

ISO 7000 : 1989

Motor vehicles; Graphic symbols – Principles, synopsis

ISO 10102 : 1990

Assembly tools for screws and nuts – Double-headed open-ended engineers' wrenches

3 Definitions

For the purpose of this European Standard the definitions given in EN 472 apply.

4 Nominal sizes

Nominal sizes of gauges are as follows: 50, 63, 80, 100, 150, 160 and 250.

See table 2 for dimensions.

5 Pressure ranges

The bar is the preferred unit of pressure, with millibar being used for ranges of 600 mbar or less.

a) Pressure ranges in bar

0 to 0,6	0 to 2,5	0 to 10
0 to 1	0 to 4	0 to 16
0 to 1,6	0 to 6	0 to 25

b) Vacuum ranges in bar

(Vacuum gauges have anti-clockwise pointer travel with increasing vacuum.)

-0,6 to 0	-1 to 0
-----------	---------

c) Combined pressure and vacuum ranges in bar

-1 to +0,6	-1 to +3	-1 to +9	-1 to +24
-1 to +1,5	-1 to +5	-1 to +15	

Ranges in millibars are acceptable providing the span is in line with 5 d).

d) Pressure ranges in millibars

0 to 1	0 to 4	0 to 16	0 to 60	0 to 250
0 to 1,6	0 to 6	0 to 25	0 to 100	0 to 400
0 to 2,5	0 to 10	0 to 40	0 to 160	0 to 600

e) Vacuum ranges in millibar

Vacuum gauges have anti-clockwise pointer travel with increasing vacuum.

-1 to 0	-4 to 0	-16 to 0	-60 to 0	-250 to 0
-1,6 to 0	-6 to 0	-25 to 0	-100 to 0	-400 to 0
-2,5 to 0	-10 to 0	-40 to 0	-160 to 0	-600 to 0

The SI-units Pascal (Pa) and Kilopascal (kPa) and Megapascal (MPa) should follow the millibar and bar series from 0 to 100 Pa up to 1000 Pa, then change to 0 to 1,6 kPa up to a 1000 kPa then change to 0 to 1,6 MPa and 2,5 MPa.

6 Accuracy classes

The accuracy class stating the limits of permissible error is expressed as a percentage of the span.

The following accuracy classes are defined: 0,6; 1; 1,6; 2,5 and 4 (see table 1).

For gauges with a pointer stop, the accuracy class will cover 10 to 100 % of the range. For gauges with a free zero, the accuracy class will cover 0 to 100 % of the range and zero shall be used as an accuracy check point.

Table 1: Nominal size compared to the accuracy class

Nominal size	Accuracy class				
	0,6	1	1,6	2,5	4
50			x	x	x
63		x	x	x	x
80		x	x	x	x
100	x	x	x	x	x
150 and 160	x	x	x	x	x
250	x	x	x		

7 Dimensions

7.1 General tolerances

General tolerances: EN 22768-1

7.2 Cases and flanges

The user will have to determine the dimensions for panel cut-out according to the manufacturer's data.

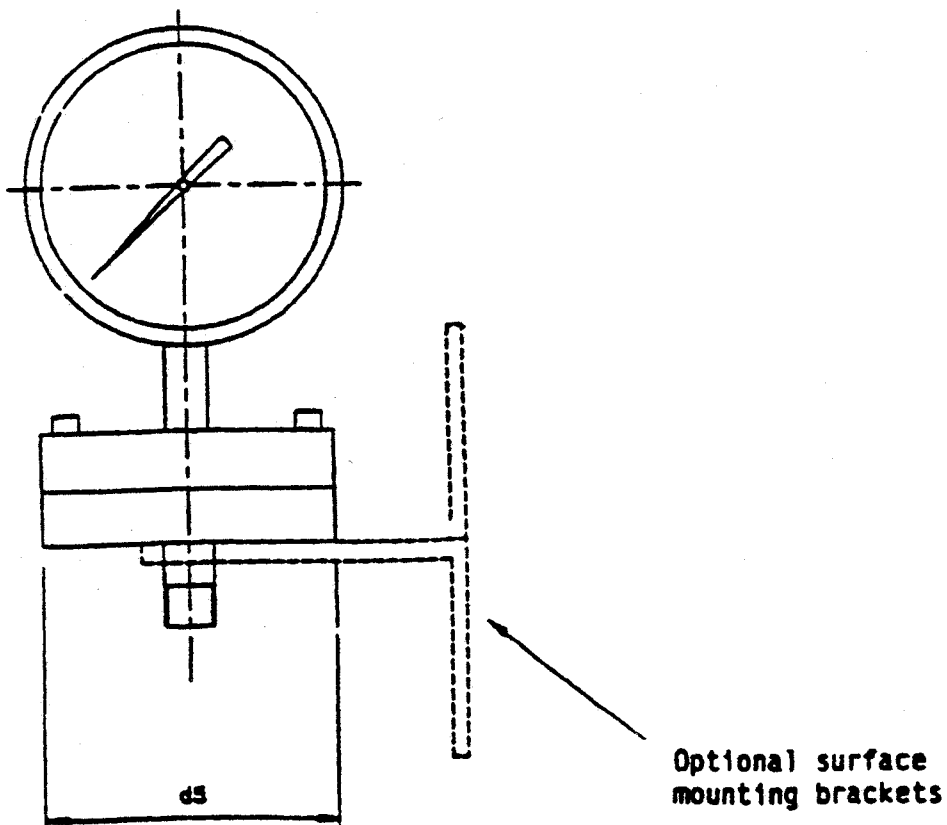
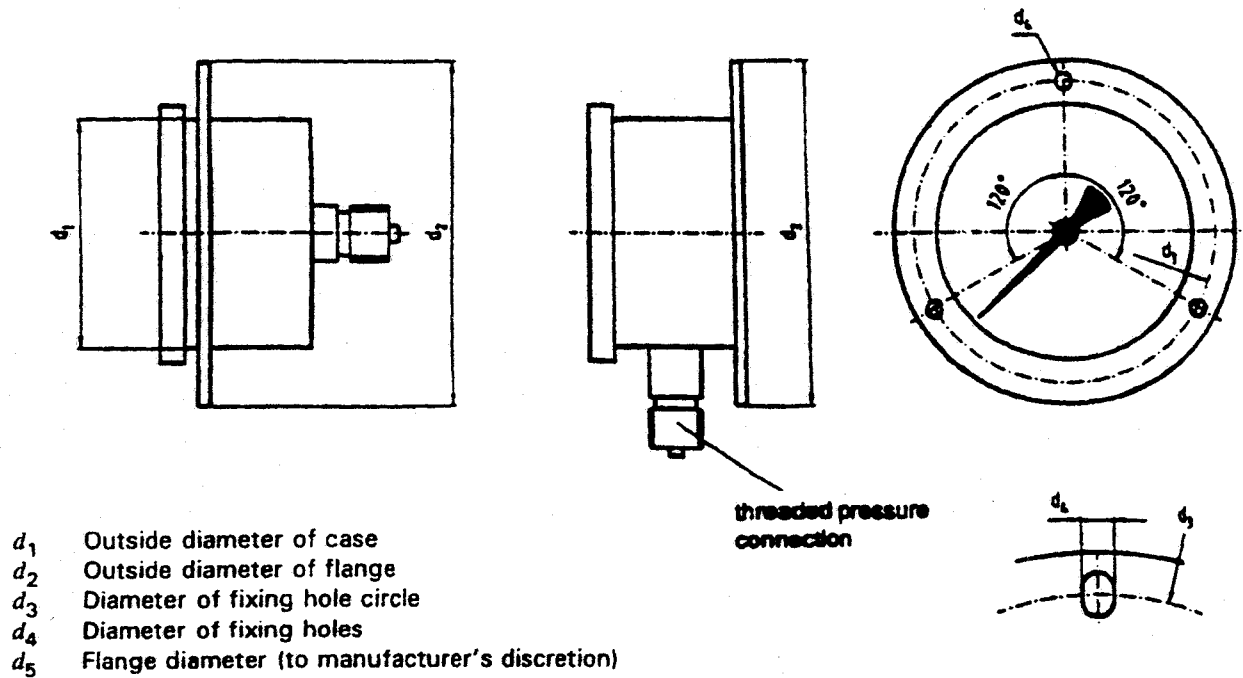

Figure 1

Table 2: Dimensions

Nominal size	d_1 min. (in mm)	d_2 max. (in mm)	d_3 (in mm)	d_4 (in mm)
50	48	71	60	3,6
63	61	86	75	3,6
80	78	110	95	5
100	97	134	118	6
150	147	186	168	6
160	157	196	178	6
250	245	290	276	7

NOTE: d_4 elongated holes can be accepted to ensure interchangeability with previous

7.3 Pressure connection

The positions of the connections can be selected from table 9 "Types of mounting and connection position".
For thread forms and sizes, see table 3.

Table 3: Thread forms and sizes

Parallel pipe threads	Taper pipe threads
G 1/8 B	1/8 - 27 NPT EXT
G 1/4 B	1/4 - 18 NPT EXT
G 3/8 B	
G 1/2 B	1/2 - 14 NPT EXT

NOTE: G 3/8 B is not preferred.

7.3.1 Screw threads

Parallel pipe threads (G) according to ISO 228-1

Taper pipe threads (NPT) according to ANSI/ASME B1.20.1

Other threads specific to certain industries are acceptable.

7.3.2 Shanks with parallel pipe threads

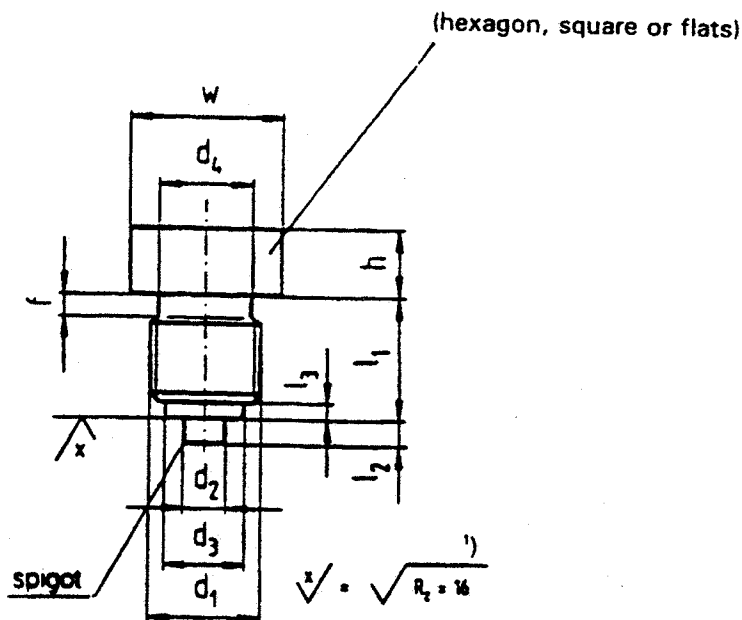

NOTE: Minimum height h of flats shall be compatible with use of standard spanners according to ISO 10102

Figure 2

Table 4: Dimensions of parallel threaded shanks

Dimensions in millimetres

Thread size d_1	d_2	d_3	d_4 min.	l_1 +0,5 0	l_2	l_3 +0,5 0	f	w min.
G 1/8 B	4	8	8	10	2	2	1,6	8
G 1/4 B	5	9,5	9,5	13	2	2	2	10
G 3/8 B	5,5	13	13	16	3	3	2	13
G 1/2 B	6	17,5	17,5	20	3	3	3	17

NOTE 1: For stainless steel screwed connection, f dimensions can be raised up to 50 %.

NOTE 2: G 1/8 B may be made without spigot.

NOTE 3: G 1/8 B may be made without groove f . In this case the length of threading must be equal to l_1 .

NOTE 4: For interchangeability with previous standards the spigot of G 1/4 B can be manufactured with diameter 4 mm.

NOTE 5: On diaphragm gauges, spigot may be omitted to allow maximum permissible bore.

¹⁾ According to ISO 1302

7.3.3 Shanks with taper pipe threads

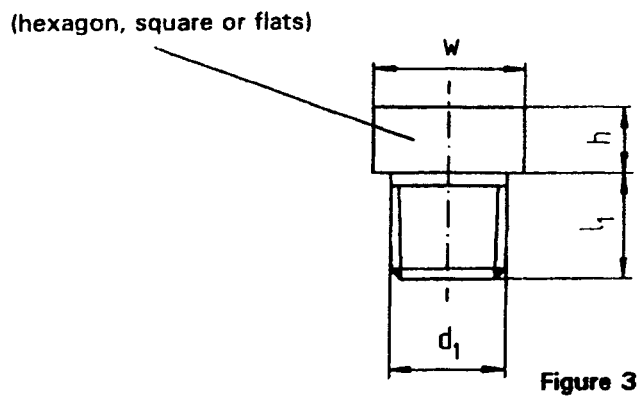

Figure 3

Table 5: Dimensions of taper threaded shanks

Dimensions in millimetres

Thread size d_1	l_1 min.	w min.
1/8-27 NPT EXT	10	8
1/4-18 NPT EXT	13	10
1/2-14 NPT EXT	18	17

NOTE: Height of flats h shall be compatible with use of spanners according to ISO 10102.

7.3.4 Parallel threaded tapped holes

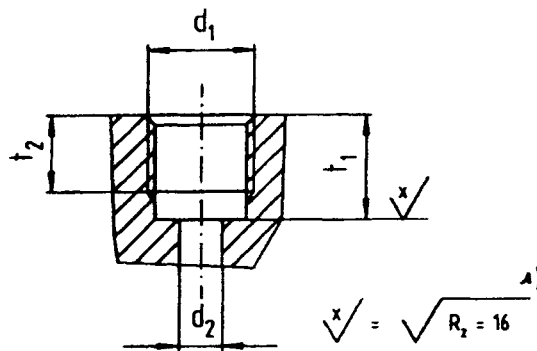

Figure 4

Table 6: Dimensions of parallel threaded tapped holes

Dimensions in millimetres

Thread size d_1	d_2	t_1 0 -0,5	t_2 min.
G 1/8	4,5	10	7,5
G 1/4	5,5	13	10
G 3/8	6,5	16	12
G 1/2	7	19	15

¹⁾ According to ISO 1302

7.3.5 Sealing washers

For use with parallel screw threads only.

NOTE: The choice of the sealing washer material depends on the pressure and the fluid to be measured.

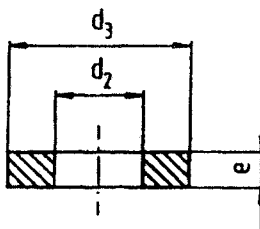

Figure 5

Table 7: Dimensions of sealing washers





Dimensions in millimetres

Thread size	d_2	d_3	$e \pm 0,2$
G 1/8 B	4,2 $\begin{smallmatrix} +0,2 \\ 0 \end{smallmatrix}$	8 $\begin{smallmatrix} 0 \\ -0,2 \end{smallmatrix}$	1,5
G 1/4 B	5,2 $\begin{smallmatrix} +0,2 \\ 0 \end{smallmatrix}$	9,5 $\begin{smallmatrix} 0 \\ -0,2 \end{smallmatrix}$	1,5
G 3/8 B	5,7 $\begin{smallmatrix} +0,3 \\ 0 \end{smallmatrix}$	13 $\begin{smallmatrix} 0 \\ -0,3 \end{smallmatrix}$	2
G 1/2 B	6,2 $\begin{smallmatrix} +0,4 \\ 0 \end{smallmatrix}$	17,5 $\begin{smallmatrix} 0 \\ -0,5 \end{smallmatrix}$	2

7.4 Types of mounting and connection position for screwed connection

The different mounting types of gauges shall be as given in table 8. When mounting, ensure that there is enough free space for the blow-out device, if any.

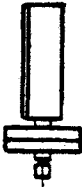
Table 8: Types of mounting and connection position

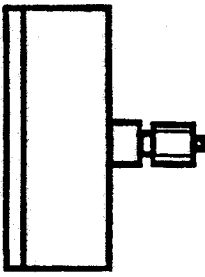
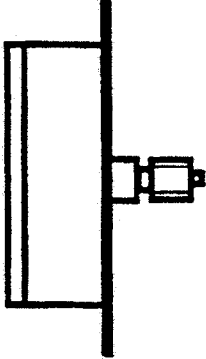
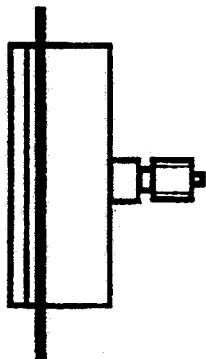
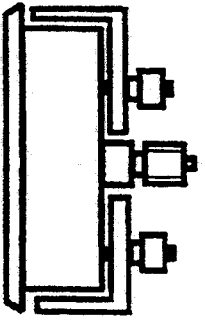
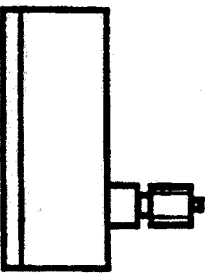
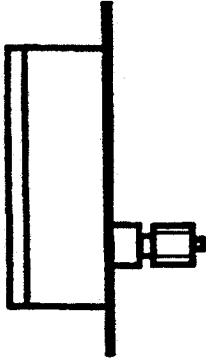
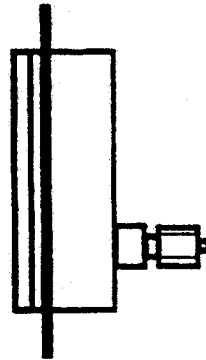
RADIAL CONNECTION	10 	11 	12  type not preferred	13 
				14 
CENTRE BACK CONNECTION	20 	21  type not preferred	22 	23 
	OFFSET BACK CONNECTION	30 	31  type not preferred	32 
DIRECT MOUNTING		SURFACE MOUNTING	FLUSH MOUNTING Three hole fixing Clamp fixing	

NOTE: Attention is drawn to Annex B for examples of flanged and special connections.

8 Wetted parts

The purchaser shall indicate to the manufacturer all information concerning the materials which are compatible with the fluid in relation to the specific conditions of measurement.

9 Requirements

The test methods for these requirements are given in clause 10.

9.1 Accuracy

The total errors of indication at reference temperature 20 °C of the gauge shall not exceed the values given in table 9.

Installation of the pressure gauges shall not cause any change of readings.

Table 9 shows the limits of permissible error in percentage of span at reference temperature 20 °C corresponding to accuracy classes.

Table 9: Maximum permissible errors

Accuracy classes	Limits of permissible error (percentage of span)
0,6	± 0,6 %
1	± 1 %
1,6	± 1,6 %
2,5	± 2,5 %
4	± 4 %

9.2 Hysteresis

Hysteresis error in pressure gauges shall not exceed the absolute value of the limits of permissible error at reference temperature 20 °C.

EXAMPLE:

Pressure gauge with maximum scale value of 10 bar, accuracy class 1. The maximum permissible hysteresis error is 1 %. The difference between the readings taken at decreasing and increasing pressure shall not exceed 0,1 bar (= 1 % of 10 bar).

9.3 Temperature effect

The variation of indication caused by effects of temperature shall not exceed the percentage values given by the formula:

$$\pm 0,06 \times (t_2 - t_1) \% \text{ of the span for capsule gauges,}$$

$$\pm 0,08 \times (t_2 - t_1) \% \text{ of the span for diaphragm gauges.}$$

Where:

t_1 is the reference temperature in degrees Celsius

t_2 is the ambient temperature in degrees Celsius

9.4 Endurance

Gauges shall withstand the steady pressure, over-pressures and cyclic pressures as described below without exceeding the specified change of accuracy (see 10.4.3). For gauges with combined pressure and vacuum ranges the endurance test required may be met with gauges of positive range only with same span.

EXAMPLE:

A gauge with a range of -1 bar to +5 bar may be substituted by a gauge with range of 0 bar to 6 bar.

9.4.1 Gauges suitable for maximum steady working pressure 75 % of the maximum scale value

9.4.1.1 Steady pressure

The gauge shall withstand a steady pressure equal to the maximum scale value for an extended period.

9.4.1.2 Over-pressure

The gauge shall withstand a 25 % over-pressure for a short period.

9.4.1.3 Cyclic pressure

The gauge shall withstand a pressure varying from 30 % to 60 % of the maximum scale value for 100 000 cycles.

9.4.2 Gauges suitable for maximum steady working pressure equal to the maximum scale value

9.4.2.1 Steady pressure and over-pressure

The gauge shall withstand a steady pressure of 1,3 times the maximum scale value for an extended period.

9.4.2.2 Cyclic pressure

The gauge shall withstand a pressure fluctuating between 30 % and 95 % of the maximum scale value for 100 000 cycles. 15 000 cycles are sufficient for gauges of class 0,6.

9.5 Operating conditions

9.5.1 Rated temperatures in service

Ambient temperature and temperature of the fluid under pressure: from $-20\text{ }^{\circ}\text{C}$ to $+60\text{ }^{\circ}\text{C}$

Minimum and maximum temperature in service for liquid-filled gauges shall be in accordance with liquid properties.

9.5.2 Rated storage temperature

Storage temperature: from $-40\text{ }^{\circ}\text{C}$ to $+70\text{ }^{\circ}\text{C}$

The gauge shall not change its appearance. The dial and pointer shall not crack, blister or change their colour.

9.5.3 Protection against ingress of water and foreign particles (Degree of protection)

Recommended minimum protection ratings in accordance with EN 60529:

- for indoor use IP 31,
- for outdoor use IP 44.

9.5.4 Effect of mechanical shock

No change of indication after application of a shock load of 150 m/s^2 .

Shock test is required for gauges accuracy classes 1 to 4 only.

9.5.5 Effect of mechanical vibration

The gauge shall be subjected to vibrations on three orthogonal axes at the following conditions:

- acceleration 5 m/s^2 ,
- range of frequency from 10 Hz to 150 Hz,
- scan rate 1 octave per minute for the period of 2 h per axis.

The change of indication after the vibration test shall not exceed 0,5 times class.

Vibration test is required for gauges accuracy classes 1 to 4 only.

9.5.6 Leak rate

The leak rate shall not exceed:

5×10^{-2} mbar · l/s for diaphragm pressure gauges,

5×10^{-3} mbar · l/s for capsule pressure gauges.

9.5.7 Mounting position

A variation of the nominal mounting position of $\pm 5^\circ$ shall not give a change of indication of more than 0,5 times class.

9.6 Dials and pointers

9.6.1 Scale angle

The scale normally covers 270° of arc.

9.6.2 Scale interval

The scale interval shall be of value that represents 1×10^n , 2×10^n or 5×10^n of the pressure unit where n is an integer number which can be positive, negative or zero.

The minimum number of minor scale divisions for each class of accuracy and size of gauge are as shown in table 10. For illustrative examples see Annex A.

Table 10: Minimum number of minor scale divisions

Scale	Nominal size	Minimum number of minor scale divisions				
		Accuracy classes				
		0,6	1	1,6	2,5	4
0 to 100	50	–	–	20	20	20
	63	–	20	20	20	20
	80	–	50	50	50	50
	100	100	50	50	50	50
	150 and 160 250	100 100	50 50	50 50	50 –	50 –
0 to 160	50	–	–	32	32	32
	63	–	32	32	32	32
	80	–	32	32	32	32
	100	80	32	32	50	50
	150 and 160 52	80 80	32 32	32 32	50 –	50 –
0 to 250	50	–	–	25	25	25
	63	–	25	25	25	25
	80	–	50	50	50	50
	100	125	50	50	50	50
	150 and 160 250	125 125	50 50	50 50	50 –	50 –
0 to 400	50	–	–	20	20	20
	63	–	20	20	20	20
	80	–	40	40	40	40
	100	80	40	40	40	40
	150 and 160 250	80 80	40 40	40 40	40 –	40 –
0 to 600	50	–	–	30	30	30
	63	–	30	30	30	30
	80	–	60	60	60	60
	100	120	60	60	60	60
	150 and 160 250	120 120	60 60	60 60	60 –	60 –

9.6.3 Scale marks

9.6.3.1 The thickness of the scale marks shall not exceed 1/5 of the scale spacing. Examples are shown in Annex A.

9.6.3.2 The scale spacing shall not be smaller than 1 mm.

9.6.3.3 The scale spacing shall be as constant as possible. The difference between the longest and shortest spacing shall not exceed 1/5 of the latter.

9.6.4 Scale numbering

Scale numbering will be at manufacturer's discretion.

Examples of scale numbering are shown in Annex A for accuracy classes from 0,6 to 4.

9.6.5 Pointer dimensions

The tip of the pointer that sweeps the scale mark shall be no wider than the minor scale mark.

The pointer shall cover between 1/10 to 9/10 of the length of the shortest lines of the minor scale marks.

The minimum lengths of pointer from axis to the tip are shown in table 11.

Table 11: Minimum length of pointer



Dimensions in millimetres

Gauge nominal size	Minimum length of pointer
50	18
63	23
80	28
100	36
150	57
160	62
250	95

9.6.6 Information on dial

- a) Unit of pressure shall be marked.
- b) Accuracy class shall be marked preferably at the end of the scale.
- c) The symbol for the type of pressure element may be marked, see table 12.

Table 12: Symbols for types of pressure elements

Element type	Symbol
Capsule	
Diaphragm	

- d) Gauges suitable for maximum steady working pressure equal to the maximum scale value shall have an identifying mark at the maximum scale value (see figure 6).

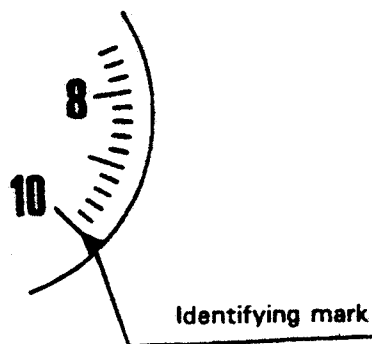

Figure 6

e) The symbol for the dial plane shall be marked when the manufacturer is required to calibrate the gauges other than in the vertical position (see figure 7).

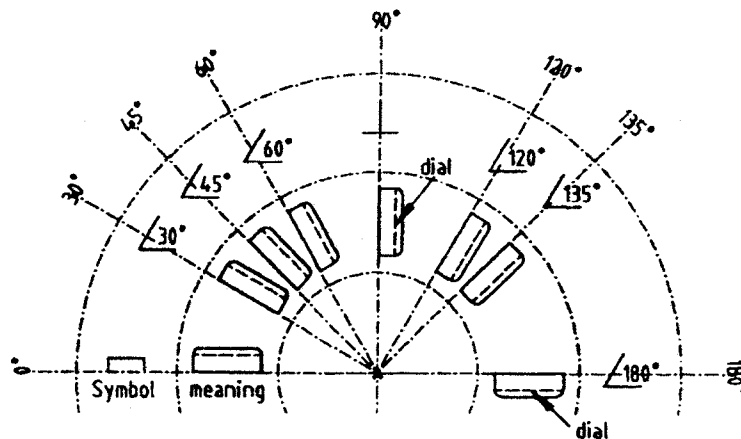

Figure 7

- f) If the customer requires the gauge to be calibrated at other than reference temperature this shall be marked. This applies to 0,6 class gauges.
- g) EN-number of this standard may be marked.
- h) Name or logo of the manufacturer and/or supplier shall be marked.
- i) Serial numbers shall be marked on all gauges which are subject to state metrological control. Serial numbers may be marked on the other gauges.
- j) Serial numbers shall be marked on all gauges which are subject to state metrological control. Serial numbers may be marked on the other gauges.

9.6.7 Pointer stop

Gauges with maximum steady working pressure equal to the maximum scale value shall have a free zero.
Gauges with maximum steady working pressure 75 % of the maximum scale value may have a free zero.

9.7 Safety

Safety gauges shall protect an operator from failure of the pressure-responsive element and the release of high pressure gases into the case by deflecting the blast and debris away from the front of the gauge.

9.7.1 Blow-out device gauges

When a blow-out device is fitted to a pressure gauge (designated by S1, see clause 12) it shall be resistant to blocking by debris and dirt and shall operate at a pressure of not more than half of the window-burst pressure.

Where the gauge is sealed for the purpose of liquid filling a blow-out device shall be fitted. These gauges shall have no special marking.

9.8 Liquid-filled gauges

Liquid-filled gauges shall have an appropriate device in order to assure atmospheric compensation.

9.9 Additional constructional requirements for gauges subject to Legal Metrology Control

For applications in Legal Metrology the appropriate OIML recommendations and the national legislation as well as the requirements below are to be observed.

9.9.1 The pressure-responsive element, the movement, the pointer, and the dial shall be installed inside an enclosing case, which can be sealed by a securing seal in order to prevent access to the parts mentioned without destruction of surrounding components.

9.9.2 The motion of the pressure-responsive element and pointer shall not be obstructed on either side of the zero mark, e. g. by means of a pointer stop, within a range corresponding to twice the permissible error in 9.1.

9.9.3 The error caused by friction of movement components shall not exceed one half of the permissible error in 9.1.

9.9.4 The scale numbering shall directly reflect the value of the pressure to be measured. The use of a factor is not permitted.

9.9.5 A place to accommodate the control mark shall be provided on the window, on a sealing lead or on the case of the gauge.

10 Testing

Reference temperature: 20 °C.

For all type tests on all accuracy classes and for production piece testing of accuracy class 0,6 the reference temperature shall be maintained within ± 2 °C. For production piece testing of all other accuracy classes the reference temperature shall be maintained within ± 5 °C. The dial shall be in the nominal position ± 3 °.

10.1 Type approval and production piece tests

Type approval tests and production piece tests shall be carried out as defined in table 13.

Table 13: Type approval/production piece tests

Type approval test				Production piece test	
Test	Test see paragraph	Requirement see paragraph	Number of samples to be tested	Test see paragraph	Requirement see paragraph
Visual inspection	-	-	4	-	-
Compliance with drawing dimensions	-	-		-	-
Leak test	10.10	9.5.6		10.10	9.5.6
Accuracy and hysteresis	10.2	9.1, 9.2		10.2	9.1, 9.2
Influence of mounting position	10.11	9.5.7	2	-	
Temperature effects	10.3	9.3			
Temperature in service	10.5	9.5.1			
Storage temperature	10.6	9.5.2			
Degree of protection	10.7	9.5.3			
Endurance steady pressure	10.4	9.4.1			
Endurance cyclic pressure	10.4	9.4.2			
Effects of mechanical vibration	10.9	9.5.5			
Effects of mechanical shock	10.8	9.5.4			
Safety: Blow-out test	10.12.2	9.7.1			

NOTE 1: The selection of the samples as well as the sequence of the testings, are at manufacturer's discretion.

NOTE 2: Production piece tests shall be carried out on each gauge accuracy classes 0,6. All other gauges may be tested at an AQL-level 1,5 according to ISO 2859-1 except for the leak test where each gauge shall be tested.

10.2 Accuracy and hysteresis

Test for accuracy and hysteresis shall be made using a test instrument with an accuracy of at least 4 times better than the accuracy of the gauge to be tested (i. e. with limits of permissible error at least 4 times smaller than the limits of permissible error of the gauge tested). The test instrument shall be traceable to a national or international standard. Test method may be either by comparing selected indications with the pressure to be applied at these indications or by comparing selected pressures with resultant indications of the gauge under test. The test shall be made with rising and falling pressure.

The number of test points shall be evenly distributed over the entire scale as follows:

- Classes 0,6: a minimum of 10 points
- Classes 1, 1,6, and 2,5: a minimum of five points
- Class 4: a minimum of four points

Each point shall be tested with rising and falling pressure. The maximum scale value is a test point. Zero is a test point when it is free.

Reading shall be obtained after the gauge has been lightly tapped. Pressure readings shall be interpolated between 1/4 and 1/10 of the distance between two scale marks.

The hysteresis is calculated from the difference in applied pressure for the same indication point or the difference in pressure indication for the same applied pressure on falling and rising pressure.

The values of measured error and hysteresis shall not exceed the values given in 9.1 and 9.2.

10.3 Temperature effect

The gauge to be tested will be subjected to the maximum and minimum ambient temperature from 9.5.1 in steps of 20 °C from reference temperature to the maximum and minimum ambient temperature. After having attained thermal equilibrium carry out the tests described in 10.2.

10.4 Endurance

The tests for the requirements given in 9.4 are as follows:

10.4.1 Gauges suitable for maximum steady working pressure 75 % of the maximum scale value

10.4.1.1 Steady pressure

The gauge shall be pressurized up to the maximum scale value and the pressure maintained for 12 h.

10.4.1.2 Over-pressure

The gauge shall be pressurized according to the requirements of 9.4.1.2 and maintained for 15 min.

10.4.1.3 Cyclic pressure

The gauge shall be subjected to a pressure fluctuating approximately sinusoidally between 30 % \pm 5 % and 60 % \pm 5 % of the maximum scale value at a frequency of between 20 and 60 cycles per minute for the number of cycles stated in 9.4.1.3.

10.4.2 Gauges suitable for maximum steady working pressure equal to the maximum scale value

10.4.2.1 Steady pressure and over-pressure

The gauge shall be pressurized up to 1,3 times the maximum scale value and the pressure maintained for 12 h.

10.4.2.2 Cyclic pressure

The gauge shall be subject to a pressure fluctuating approximately sinusoidally between 30 % \pm 5 % and 95 % \pm 5 % of the maximum scale value at a frequency of between 20 and 60 cycles per minute for the number of cycles stated in 9.4.2.2.

10.4.3 Accuracy after endurance test

After completion of the endurance testing the gauge should be left undisturbed for 1 h. Then the error when tested in accordance with 10.2 shall not exceed 1,2 times class.

10.5 Rated temperatures in service

The pressure element assembly is to be placed in a climatic chamber for 24 h at the upper temperature extreme, at a pressure of 2,5 times maximum scale value.

Afterwards the leak test is carried out at ambient room temperature as 10.10. After this test measuring performance is not required.

10.6 Rated storage temperatures

The complete, unpressurized gauge is to be placed in a climatic chamber for minimum 24 h at each temperature extreme.

Inspect immediately for any changes in appearance and after one hour at reference temperature test for accuracy and hysteresis, and leakage to 10.2 and 10.10.

After the test the gauge shall satisfy the requirements given in 9.1, 9.2 and 9.5.2 for accuracy and hysteresis and no change of appearance shall occur.

10.7 Protection against ingress of water and foreign particles (Degree of protection)

As specified in EN 60529

10.8 Effect of mechanical shock

Shock test equipment as given in EN 60068-2-27. Tests with 150 m/s² half sinewave in the 2 directions of three rectangular axes. Perform three shock loads in each plane, this being 18 shocks altogether. The gauge shall be pressurized with 50 % of maximum scale value and be mounted in its normal manner. After the test the gauge shall satisfy the requirements for accuracy and hysteresis as given in 9.1 and 9.2.

10.9 Effect of mechanical vibration

The gauge shall be mounted on vibration test equipment as given in EN 60068-2-6 in its normal manner and tested at conditions as described in 9.5.5. It shall be pressurized to 50 % of the maximum scale value. After the test the change of accuracy shall not exceed 0,5 times class.

10.10 Leak test

The leak test shall be conducted at maximum scale reading. The test fluid shall be air.

10.11 Mounting position

The gauge shall be mounted inclined forwards at 5° to its normal position and tested for accuracy and hysteresis in accordance with 10.2. The change in indication shall not exceed 0,5 times class. It shall then be tested similarly inclined backwards, to right, and to left.

10.12 Safety

10.12.1 Constructional requirements

The existence of the blow-out device shall be verified by inspection.

10.12.2 Blow-out test

The operation of the blow-out device or blow-out back shall be verified, and the pressure at which it occurs recorded, by pressurizing the case through the pressure gauge connection (with the pressure-responsive element removed). Leakage points other than the blow-out device shall be sealed with a low strength sealant. Gauge cases intended for liquid filling shall be tested filled and unfilled. When connected to a gas supply of increasing pressure (and flow rate if required) the blow-out device shall be expelled or open without failure of the window, expulsion of the window or any other component.

The blow-out device will then be blocked and the burst pressure of the window will be measured.

11 Packaging for transportation

In consideration of the means of transportation selected, gauges shall be packed such as to preserve measurement properties, exclude damage and maintain accuracy within the limits of permissible error.

12 Designation

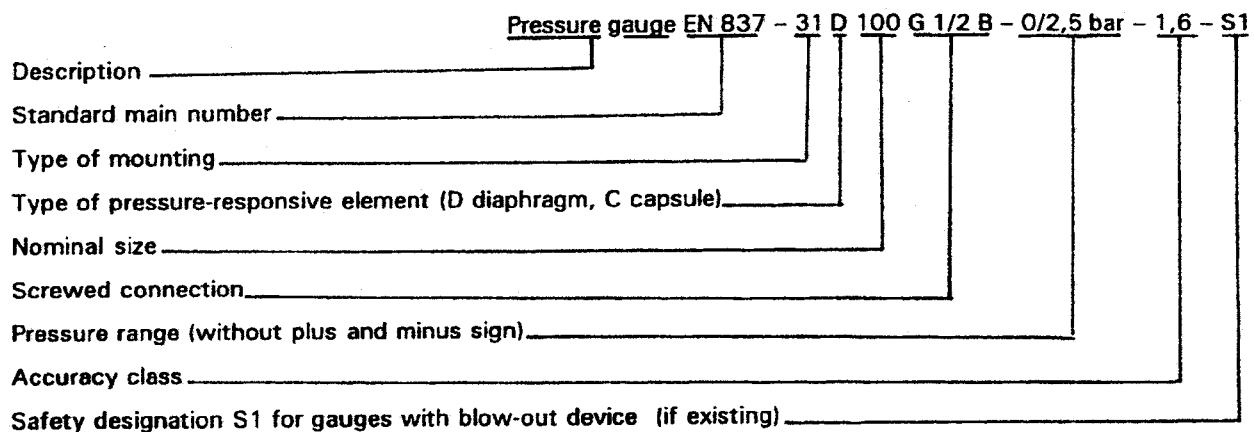

NOTE: Designation for combined pressure and vacuum ranges and for vacuum ranges without plus and minus sign (e. g. 1/0,6, 0,6/0)

Annex A (informative)

Examples of scale numbering for accuracy classes from 0,6 to 4

Table A.1: Nominal ranges, scale spacing and scale numbering of pressure gauges of class 0,6

nominal size	scale	number of minor scale division	scale interval	scale spacing and scale numbering
100 to 250	0 to 1 0 to 10 0 to 100 0 to 1000 -1 to 0 -1 to 9	100	0,01 0,1 1 10 0,01 0,1	 0 0,1 0,2 0,3 0,4 0,5 0,6 0,7 0,8 0,9 1,0 0 1 2 3 4 5 6 7 8 9 10 0 10 20 30 40 50 60 70 80 90 100 0 100 200 300 400 500 600 700 800 900 1000 -1 -0,9 -0,8 -0,7 -0,6 -0,5 -0,4 -0,3 -0,2 -0,1 0 -1 0 1 2 3 4 5 6 7 8 9
100	0 to 1,6 0 to 16 0 to 160 0 to 1600 -1 to 0,6 -1 to 15	80	0,02 0,2 2 20 0,02 0,2	 0 0,2 0,4 0,6 0,8 1,0 1,2 1,4 1,6 0 2 4 6 8 10 12 14 16 0 20 40 60 80 100 120 140 160 0 200 400 600 800 1000 1200 1400 1600 -1 -0,8 -0,6 -0,4 -0,2 0 0,2 0,4 0,6 -1 0 2 4 6 8 10 12 14 15
150 to 250	0 to 1,6 0 to 16 0 to 160 0 to 1600 -1 to 0,6 -1 to 15	80	0,02 0,2 2 20 0,02 0,2	 0 0,1 0,2 1,4 1,5 1,6 0 1 2 14 15 16 0 10 20 140 150 160 0 100 200 1400 1500 1600 -1 -0,9 -0,8 0,4 0,5 0,6 -1 0 1 13 14 15
100	0 to 2,5 0 to 25 0 to 250 -1 to 1,5 -1 to 24	125	0,02 0,2 2 0,02 0,2	 0 0,5 1,0 1,5 2,0 2,5 0 5 10 15 20 25 0 50 100 150 200 250 -1 -0,5 0 0,5 1 1,5 -1 0 5 10 15 20 24
150 to 250	0 to 2,5 0 to 25 0 to 250 -1 to 1,5 -1 to 24	125	0,02 0,2 2 0,02 0,2	 0 0,2 2,4 2,5 0 2 24 25 0 20 240 250 -1 -0,8 1,4 1,5 -1 0 2 22 24

(continued)







nominal size	scale	number of minor scale division	scale interval	scale spacing and scale numbering
100 to 250	0 to 4 0 to 40 0 to 400 -1 to 3	80	0,05 0,5 5 0,05	 0 0,5 1 1,5 2 2,5 3 3,5 4 0 5 10 15 20 25 30 35 40 0 50 100 150 200 250 300 350 400 -1 -0,5 0 0,5 1 1,5 2 2,5 3
100	0 to 0,6 0 to 6 0 to 60 0 to 600 -1 to 5 -0,6 to 0	120	0,005 0,05 0,5 5 0,05 0,005	 0 0,1 0,2 0,3 0,4 0,5 0,6 0 1 2 3 4 5 6 0 10 20 30 40 50 60 0 100 200 300 400 500 600 -1 0 1 2 3 4 5 -0,6 -0,5 -0,4 -0,3 -0,2 -0,1 0
150 to 250	0 to 0,6 0 to 6 0 to 60 0 to 600 -1 to 5 -0,6 to 0	120	0,005 0,05 0,5 5 0,05 0,005	 0 0,05 0,55 0,6 0 0,5 5,5 6 0 5 55 60 0 50 550 600 -1 -0,5 4,5 5 -0,6 -0,55 -0,05 0

Table A.2: Nominal ranges, scale spacing and scale numbering of pressure gauges of classes 1, 1,6, 2,5 and 4

nominal size	scale	number of minor scale division	scale interval	scale spacing and scale numbering
50 to 63	0 to 1 0 to 10 0 to 100 0 to 1000	20	0,05 0,5 5 50	 0 0,2 0,4 0,6 0,8 1,0 0 2 4 6 8 10 0 20 40 60 80 100 0 200 400 600 800 1000
	-1 to 0 -1 to 9		0,05 0,5	 -1 -0,8 -0,6 -0,4 -0,2 0 -1 0 2 4 6 8 9
80 to 250	0 to 1 0 to 10 0 to 100 0 to 1000	50	0,02 0,2 2 20	 0 0,2 0,4 0,6 0,8 1,0 0 2 4 6 8 10 0 20 40 60 80 100 0 200 400 600 800 1000
	-1 to 0 -1 to 9		0,02 0,2	 -1 -0,8 -0,6 -0,4 -0,2 0 -1 0 2 4 6 8 9
50 to 250	0 to 1,6 0 to 16 0 to 160 0 to 1600	32	0,05 0,5 5 50	 0 0,4 0,8 1,2 1,6 0 4 8 12 16 0 40 80 120 160 0 400 800 1200 1600
	0 to 1,6 0 to 16 0 to 160 0 to 1600		32	0,05 0,5 5 50
	-1 to 0,6	32		0,05
	-1 to 15		0,5	 -1 0 5 10 15
250	only Class 1 gauges	32	0,05 0,5 5 50	 0 0,2 0,4 0,6 0,8 1,0 1,2 1,4 1,6 0 2 4 6 8 10 12 14 16 0 20 40 60 80 100 120 140 160 0 200 400 600 800 1000 1200 1400 1600
	-1 to 0,6 -1 to 15		0,05 0,5	 -1 -0,8 -0,6 -0,4 -0,2 0 0,2 0,4 0,6 -1 0 2 4 6 8 10 12 14 15

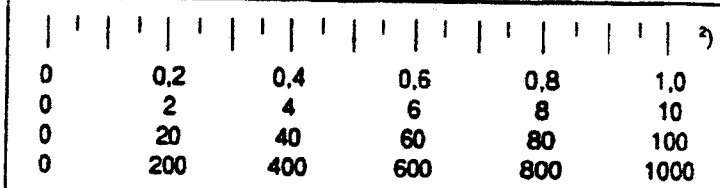
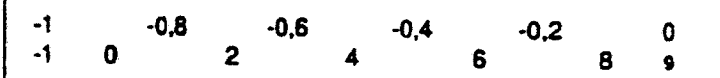
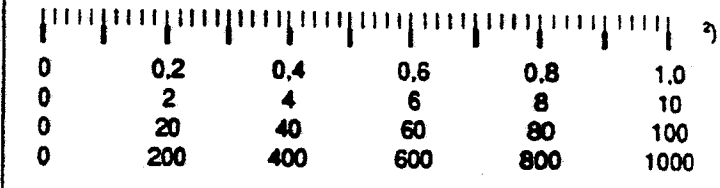
²⁾ The two different kinds of scale marks are acceptable variations at the manufacturers discretion.

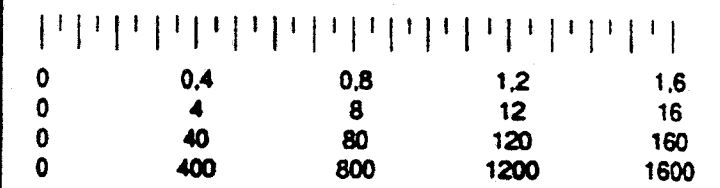
(continued)

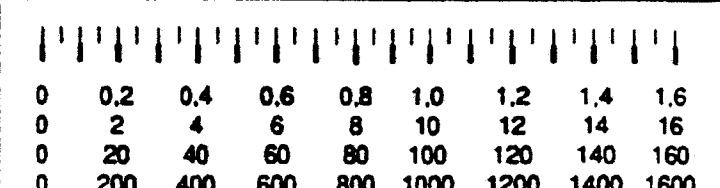
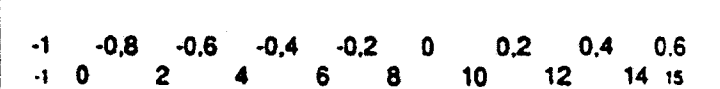
Table A.2 (concluded)

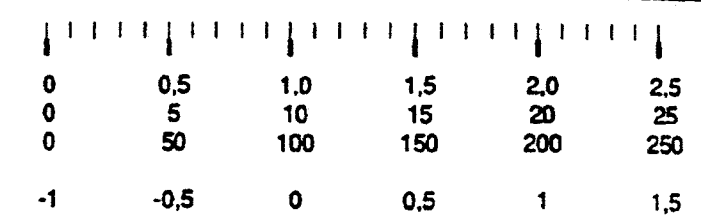
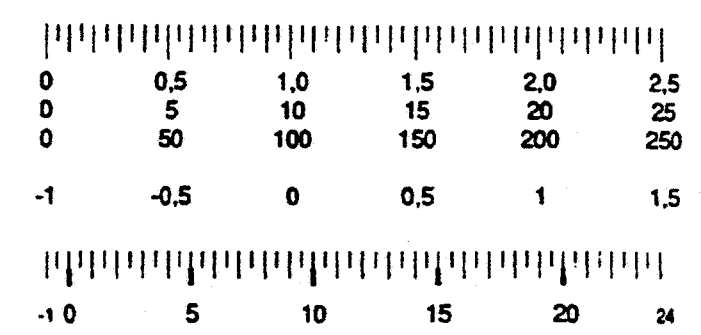
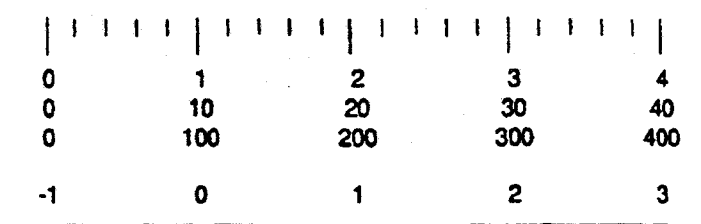
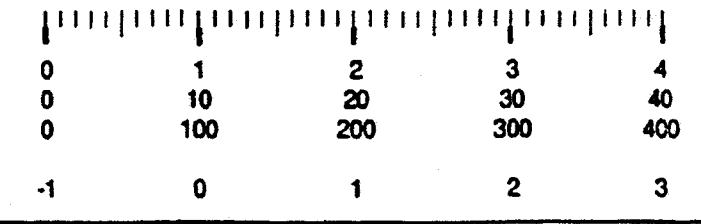
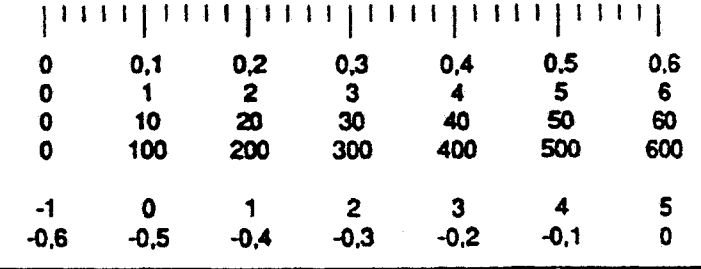
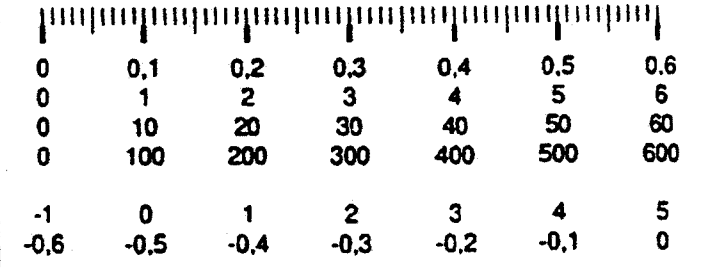
nominal size	scale	number of minor scale division	scale interval	scale spacing and scale numbering
50 to 63	0 to 2,5 0 to 25 0 to 250 -1 to 1,5	25	0,1 1 10 0,1	
80 to 250	0 to 2,5 0 to 25 0 to 250 -1 to 1,5 -1 to 24	50	0,05 0,5 5 0,05 0,5	
50 to 63	0 to 4 0 to 40 0 to 400 -1 to 3	20	0,2 2 20 0,2	
80 to 250	0 to 4 0 to 40 0 to 400 -1 to 3	40	0,1 1 10 0,1	
50 to 63	0 to 0,6 0 to 6 0 to 60 0 to 600 -1 to 5 -0,6 to 0	30	0,02 0,2 2 20 0,2 0,02	
80 to 250	0 to 0,6 0 to 6 0 to 60 0 to 600 -1 to 5 -0,6 to 0	60	0,01 0,1 1 10 0,1 0,01	

Annex B (informative)

Examples of flanged and special connections

Table B.1: Direct mounting diaphragm gauge with flanged and flow through connections

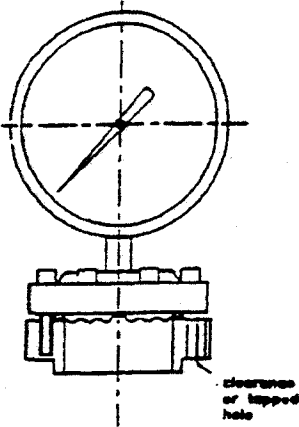
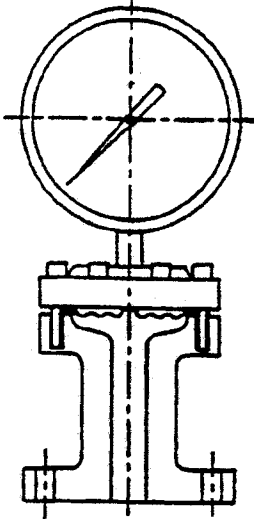
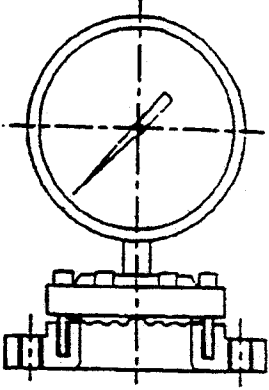
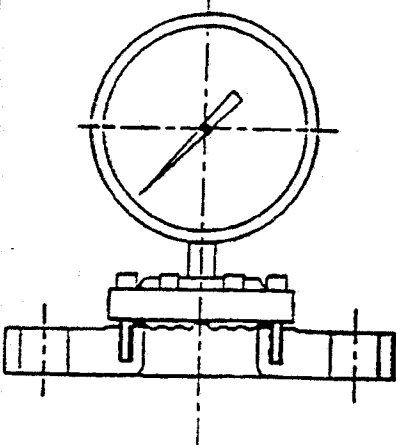
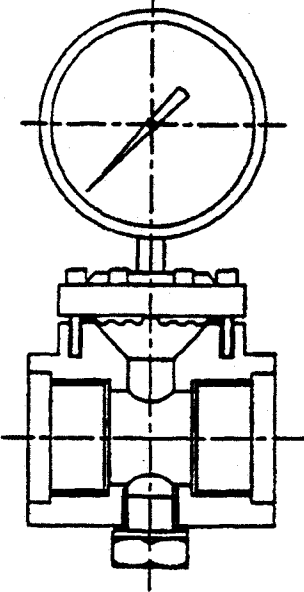
<p>15 Non-standard flange to be defined by agreement between manufacturer and user</p>  <p>clearance of tapped hole</p> <p>Fixing holes tapped to accept bolts specified by agreement between manufacturer and user.</p>	<p>16 Mounting on small diameter standard flange</p>  <p>Fixing holes specified by flange standard with clearance on upper side to allow rotation of nut. Size of thread specified by flange standard.</p>	<p>17 Mounting on flat flange with tapped holes</p>  <p>Fixing holes specified by flange standard. Tapped flange holes to accept studs. Size of thread specified by flange standard.</p>
<p>18 Mounting on standard flat flange</p>  <p>Fixing holes specified by flange standard with clearance on upper side to allow rotation of nut. Size of thread specified by flange standard.</p>	<p>19 Flow through connection</p> 	<p>CUSTOMERS SHALL SUPPLY WITH ORDER, THE FLANGE STANDARD NUMBER, BORE SIZE AND RATING</p>
<p>The maximum scale value of the instrument shall NOT exceed the rating of the flange. The hydraulic test pressure of the flange and the overpressure during test is limited to the hydraulic test pressure of the flange.</p>		